

# **USER'S MANUAL**

## ***TLMX Attachment*** ***TUCK EMBROIDERY***



## Foreword

This manual is a guide book for using an option of TAJIMA embroidery machine “Tuck embroidery attachment”. Please use this device after understanding the contents.

This manual may contain discrepancies in detailed information when compared with this device due to difference of target model, continued research and improvements. If any question about the product or contents of this manual arises, please consult your TAJIMA distributor.

Please keep this manual with care near the machine for quick reference.

**TISM Co.,Ltd.**

## Important safety instructions

Items that require your special attention on operation are specified below.



Indicates that there is a lot of danger of death or serious injuries<sup>[\*A]</sup> if the instruction is not observed.



Indicates that there is a likelihood of death or serious injuries<sup>[\*A]</sup> if the instruction is not observed.





Indicates a potentially hazardous situation which, if not avoided, may result in minor or moderate injury<sup>[\*B]</sup> or property damage.

[\*A] A condition caused by electric shock, injury, fracture of a bone, etc., that leads to aftereffects, or an injury that necessitates hospitalization or visits to a hospital over a long period.

[\*B] An injury that does not necessitate hospitalization or visit to a hospital over a long period.

 : Prohibited items

 : Items that may cause electric shock if not observed

 : Items that must be followed carefully to ensure safe operation

|           |  |   |
|-----------|--|---|
| Chapter 1 | Configuration of the device .....              | 1 |
| Chapter 2 | Attaching and adjusting .....                  | 2 |
| 1.        | Bobbin bracket .....                           | 2 |
| 2.        | Tape guide attachment .....                    | 2 |
| 3.        | Height adjustment of rotating ring .....       | 3 |
| 4.        | Tape feed attachment .....                     | 3 |
| 5.        | Adjustment of tape feed attachment .....       | 4 |
| 6.        | Adjustment of tape feed plate .....            | 4 |
| Chapter 3 | Tuck embroidery procedure .....                | 5 |
| 1.        | Final adjustment of tape feed attachment ..... | 5 |
| 2.        | Tape setting .....                             | 6 |
| Chapter 4 | Sewing condition and setting .....             | 6 |
| 1.        | Sewing condition .....                         | 6 |
| 2.        | Setting .....                                  | 7 |
| Chapter 5 | Sewing .....                                   | 7 |
| 1.        | Before start .....                             | 7 |
| 2.        | Type of pattern .....                          | 7 |
| 3.        | Arc and bend .....                             | 8 |
| 4.        | When adjustment is necessary .....             | 8 |
| 5.        | At the end of design .....                     | 8 |

## Chapter 1 Configuration of the device

Tuck embroidery attachment is composed of the bobbin attachment 1, tape feed attachment 2, and tape guide attachment 3.

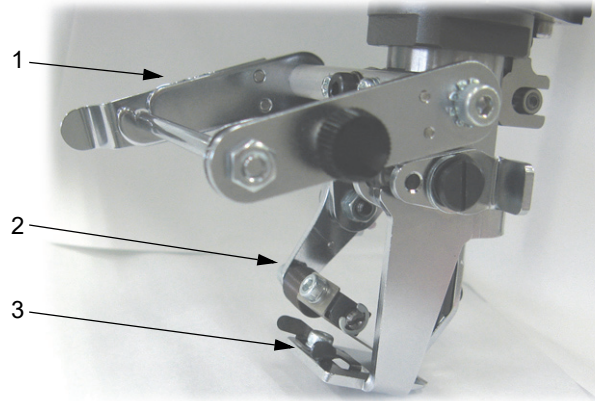

- Bobbin attachment

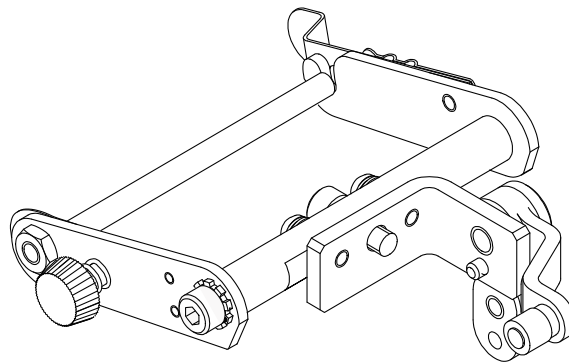

- Tape feed attachment

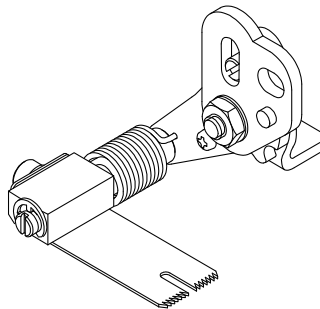

- Tape guide attachment

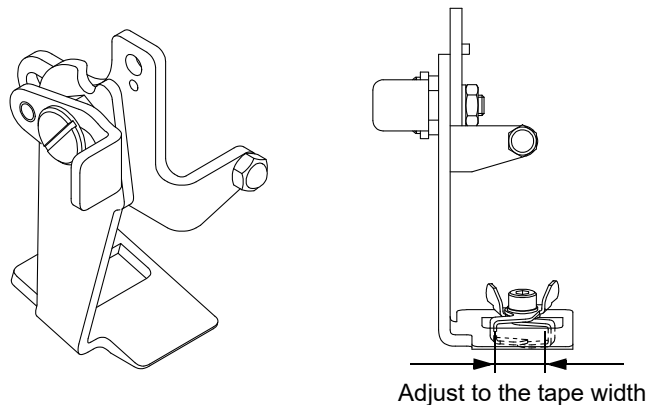

## Chapter 2 Attaching and adjusting

 **WARNING**

Turn OFF the power when you perform working/adjusting.

When the power is turned ON at setting on the panel, be sure to turn OFF the power after the operation.



When you attach attachment for tuck embroidery, double-bobbin spec. is not available for tuck embroidery.

### 1. Bobbin bracket

(1) When the N-Pipe connecting block 1 is attached, detach it.

(2) Fix the bobbin attachment 2 by using the screw 3.

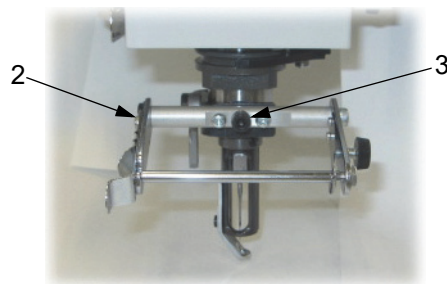
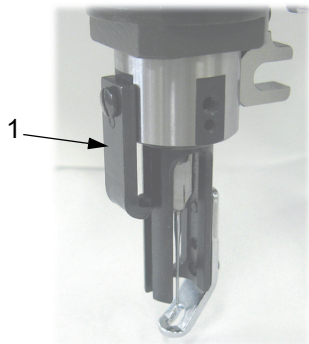

### 2. Tape guide attachment

(1) Make a clearance between the bobbin 1 and the M-axis pulley cover 2 become 2 mm or more, and fix the screw 3.

(2) Press "SET+E" on the panel to set the N-Pipe 7 to the upper position.

(3) Before attaching the tape guide attachment 4 to the head, lock the tape guide attachment 4 by using the retracting lever stopper 5.

(4) Fix the set screw 8 temporarily while putting the pin with screw 6 into the groove of the N-Pipe 7.

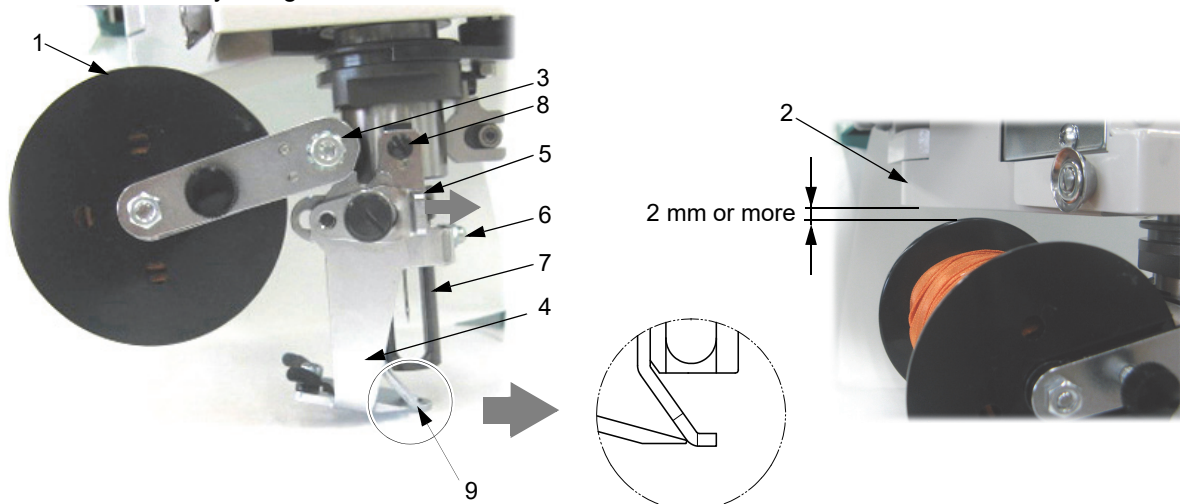

(5) After lowering the N-Pipe 7 manually to make it touch the needle plate in the state of the power turned OFF, make the tip of the tape guide attachment 4 touch the guide A 9 and fix the tape guide attachment 4 by using the screw 8.



Make the tip touch the guide A.

## Chapter 2 Attaching and adjusting

### 3. Height adjustment of rotating ring

- (1) Loosen the zigzag swing upper dead point stopper set screw 1.
  - (2) Tighten the screw 1 so that a clearance between the bottom of the rotating ring 2 and the connecting arm 3 becomes 7 mm as much as possible.
-  Adjusting range is 7 to 9 mm. Values outside this range are not available for adjustment.
  -  When it is unnecessary to change height in setting for zigzag swing embroidery etc., adjustment is unnecessary.
  -  When height adjustment is not performed, adjustment will be performed by other parts (Refer to p.5). When stitches are not stable, perform adjustment by the method described above.

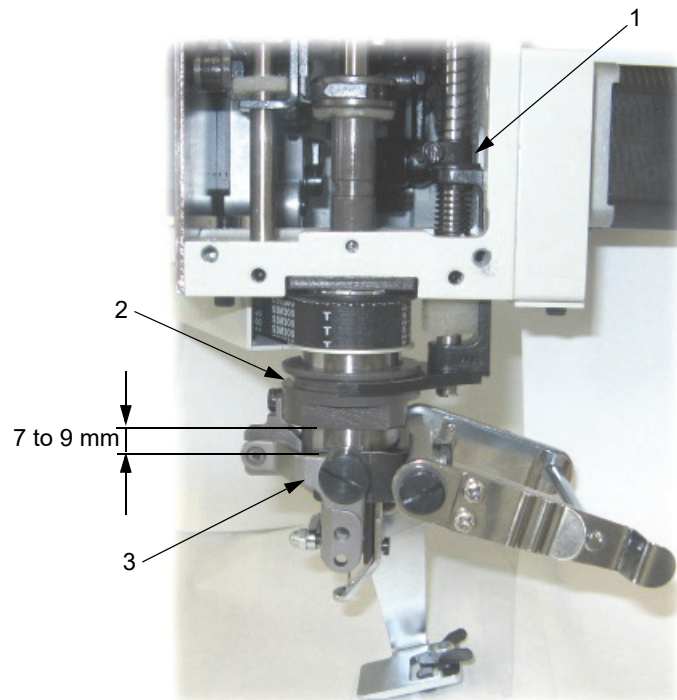

### 4. Tape feed attachment

- (1) Attach the tape feed attachment 2 by using the screw 1.
- (2) Set the tape feed attachment 2 to the fixed position (photo below), and lower the tape feed stopper 3 to the direction indicated by the white arrow to be locked.
- (3) Lower the N-Pipe 4 by hand, and adjust the tape feed plate 5 at the height of 2 mm from the needle plate as shown in the figure below. Fix the tape feed plate 5 by using the screw 1.

It comes out by about 1 mm from the bent section of guide A.

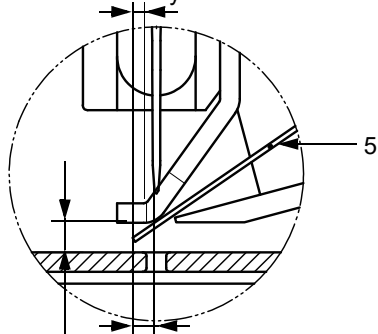

It comes out by about 2 mm from needle locating position.

Lower dead point 2 mm

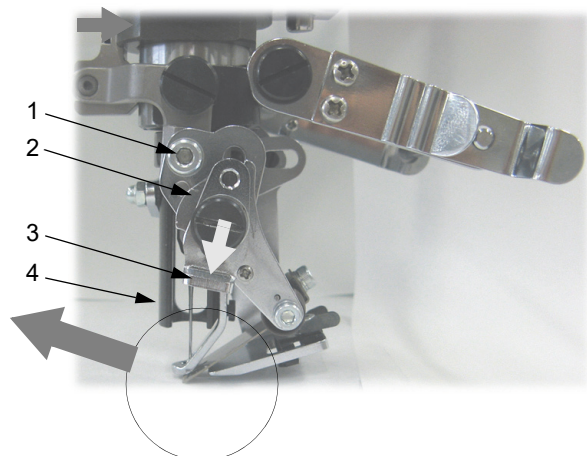

## 5. Adjustment of tape feed attachment

- (1) Press "SET+E" on the panel to set the N-Pipe 1 to the upper position, and raise the tape feed stopper 2 to release the lock.
- (2) Rotate the tape feed lever 3 as shown in the photo below, and lower the tape feed stopper 2 again to be locked.
- (3) As the photo below shows, rotate and adjust the shaft pin attached to the tip of the screw 4 so that a clearance between the tip of the tape feed plate 5 and the connecting lever holder 6 becomes 3 to 4 mm by loosening the screw 4. Then, tighten the screw 4.

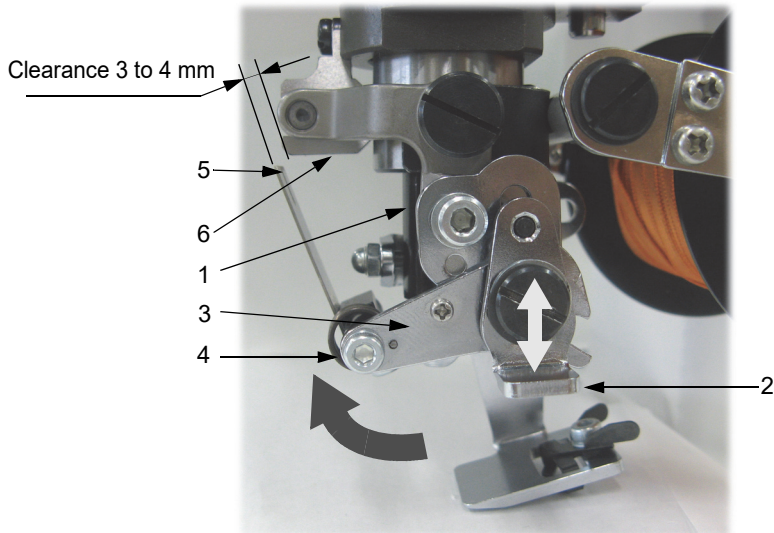

## 6. Adjustment of tape feed plate

- (1) Set the tape feed lever 1 to the fixed position, and lower the tape feed stopper 2 to be locked.
- (2) Rotate the main shaft by using the accessory main shaft handle to lower the needle.
- (3) Adjust the position of needle in X direction so that the needle does not touch the slit 4 of the tape feed plate 3, and tighten the screw 5. At this time, fix the tape feed plate 3 to the block 6 so that there is no gap.

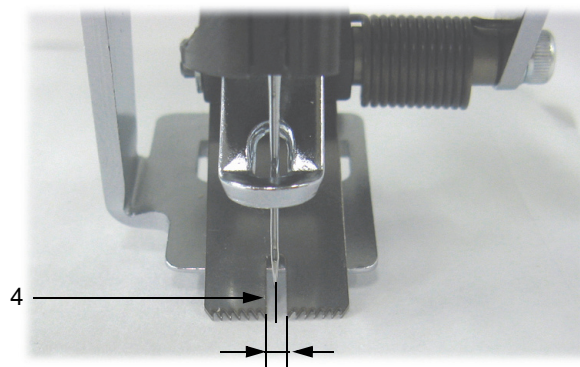
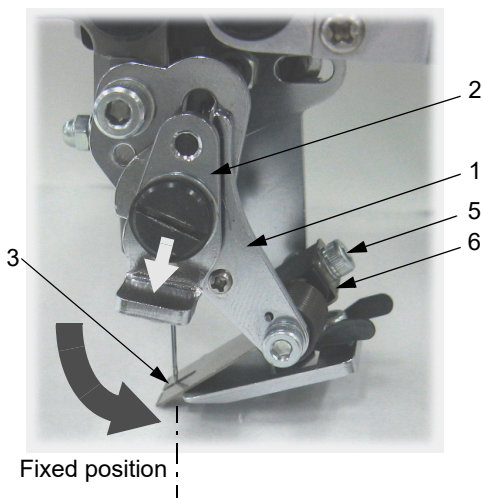

Adjust  
position in X direction so that the needle does

## Chapter 3 Tuck embroidery procedure

### 1. Final adjustment of tape feed attachment

- (1) Set the fabric to be sewn.
- (2) Loosen the screw 1 to set the tape feed lever 2 to the fixed position, and lock the tape feed lever 2 by using the tape feed stopper 3.
- (3) Press "SET+E" on the panel to set the N-Pipe 4 to the upper position.
- (4) Push the tape feed plate 5 to the tape feed guide 6 by finger, and rotate the tape feed lever 2 to the direction indicated by the black arrow until the end section touches the fabric.
- (5) Tighten the screw 1 to fix the tape feed lever 2.

 When thickness of the fabric to use is changed, perform this adjustment.

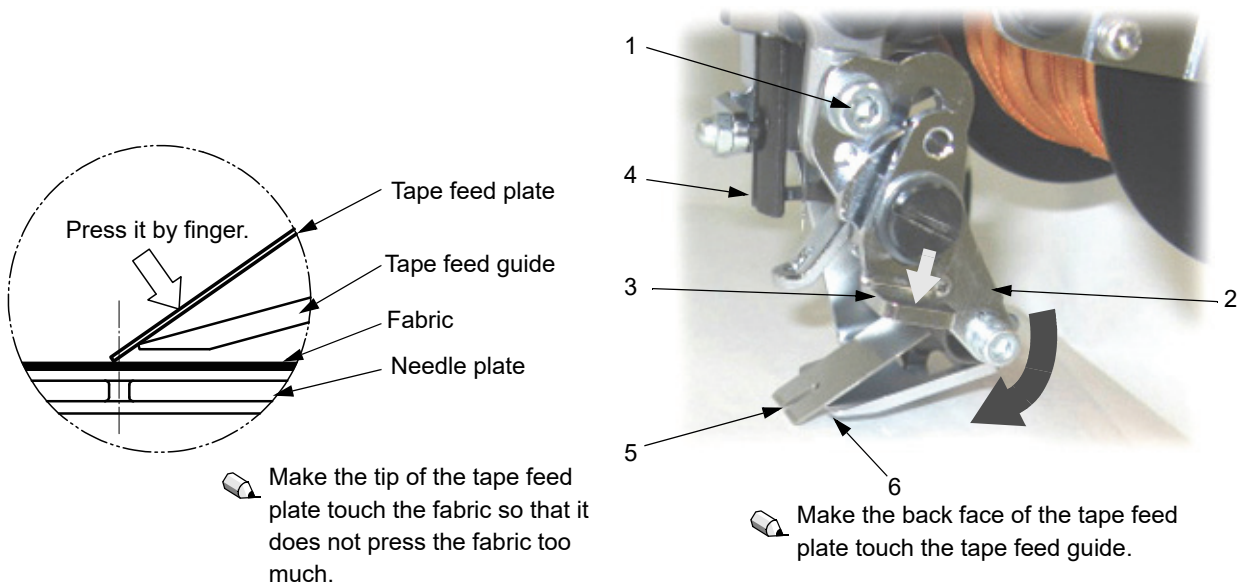

 Pay attention so that the tape feed plate 5 will not become in the state of the photos below.

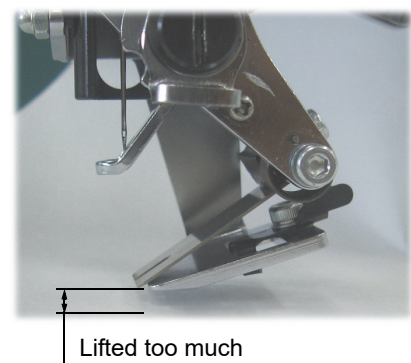
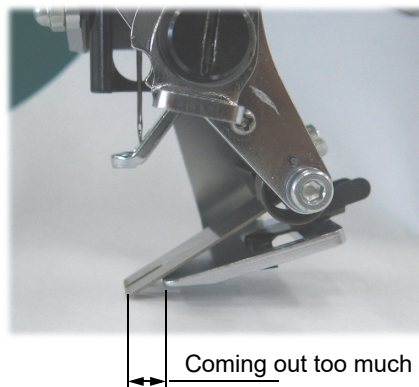

## 2. Tape setting

- (1) Set the tape bobbin and pass the tape to the tape guide.

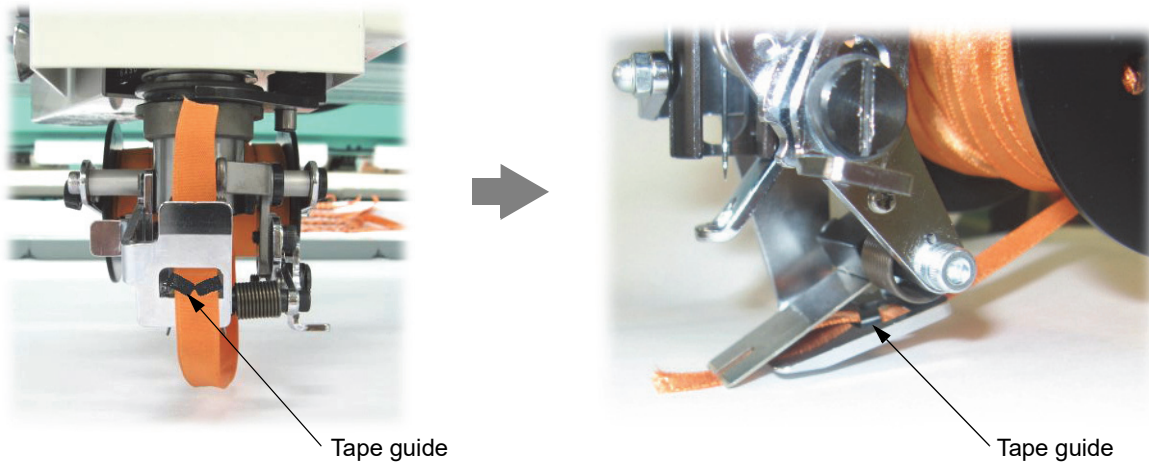

- (2) Adjust the tape guide position so that the needle locating position becomes the center of tape width.

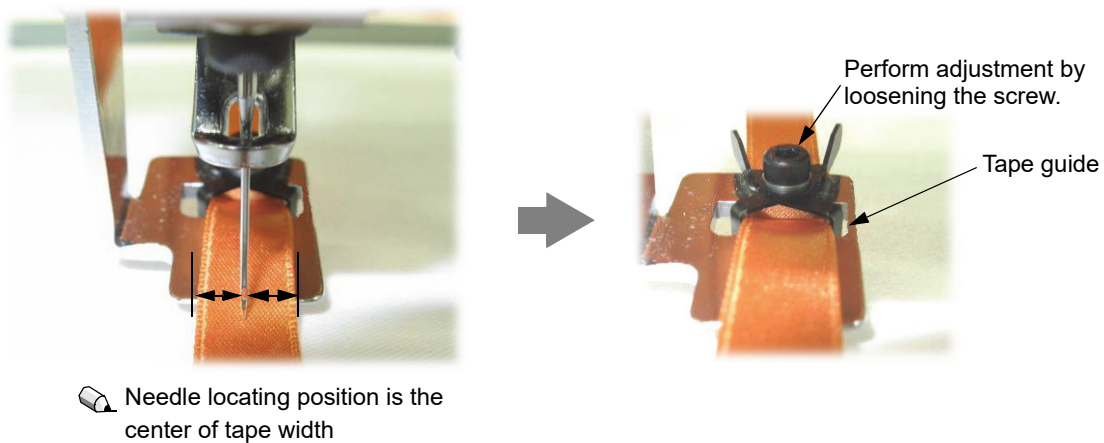

## Chapter 4 Sewing condition and setting

## 1. Sewing condition

## (1) Design

Within a range of running stitch length 1 to 3 mm. 2 mm is recommended.

## (2) Fabric to be sewn

Use the fabric of thickness 0.5 mm or less.

## (3) Tape

Use the tape of thickness 0.8 mm or less, width 6 to 11 mm and easy to be folded in tucks.

## (4) Embroidery space

Embroidery space will be reduced by 80 mm (front and rear: each 40 mm) in Y direction and 20 mm (right and left: each 10 mm) in X direction due to dimensions of the attachment.

## Chapter 5 Sewing

### 2. Setting

Settings on the operation panel are shown in the chart below. Regarding detailed setting method, refer to the "User's Manual" of the machine.

| Select key | Item                                     | Setting value                               |
|------------|--|---|
| B ▶ 6      | Stitch Type Selection                    | H (Tuck embroidery)                         |
| C ▶ 1      | The number of revolutions of the machine | 600 rpm                                     |
| F6 ▶ 2     | N-Pipe stroke                            | 2.0 (recommended)                           |
| F6 ▶ 3     | Lower Dead Point                         | 2.0 (depending on thickness of tape/fabric) |
| F6 ▶ 7     | Times of Tuck feed                       | 0 to 5                                      |
|            | Stitches before stopping Tuck feed       | 0 to 9*                                     |

\*The number of running stitches to sew a design data

## Chapter 5 Sewing

### 1. Before start

Make the tape come out by about 10 to 20 mm from the tape feed plate.

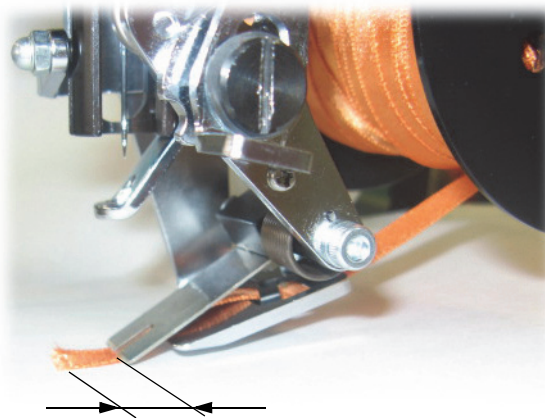

Make the tape come out by 10 to 20 mm.

### 2. Type of pattern

There are following six kinds of tuck embroidery patterns as the photo below shows. Select a pattern by setting on the panel.

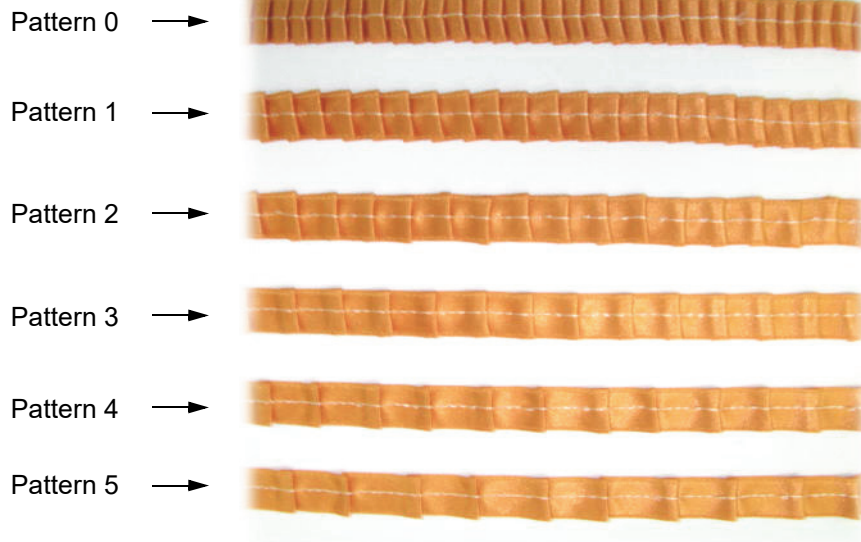

### 3. Arc and bend

Set a radius of an arc to 3 times or more of tape width.  
Set a bending angle to 90° or more.

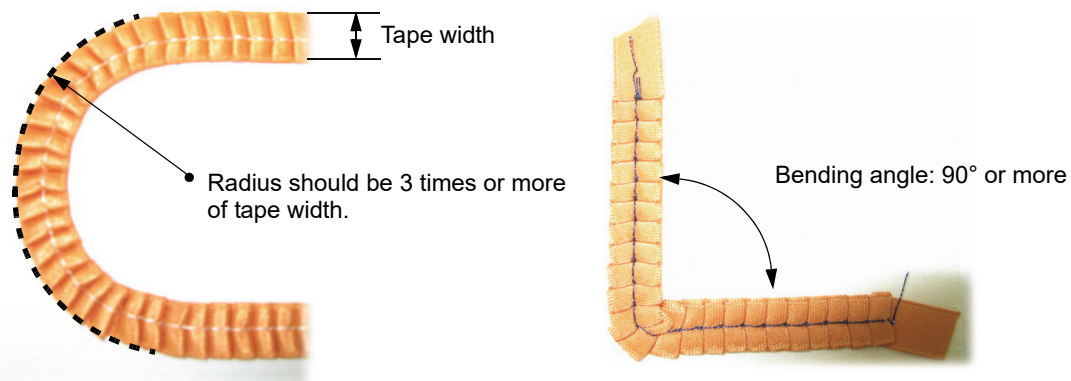

### 4. When adjustment is necessary

In case of the description below, it is necessary to perform setting again. Refer to “1. Final adjustment of tape feed attachment (p.5)”.

Example: when running stitch length is 1.5 mm or less

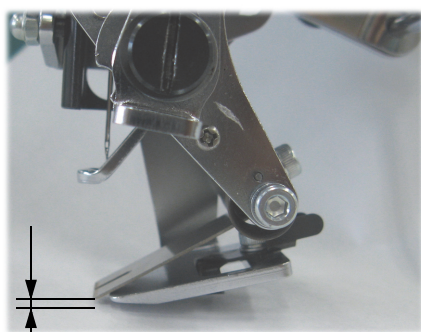

Make a clearance of 1 mm from the surface of the fabric.

The machine sews the tape with tuck interval narrowed.

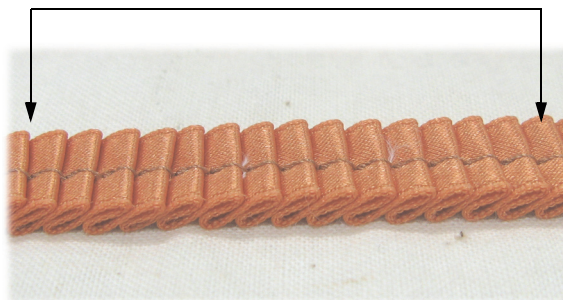

### 5. At the end of design

(1) Treat tape and upper thread by using scissors.



## Chapter 5 Sewing

- (2)** Retract the tape feed plate 1 and tape feed guide 2, and lock them by using the tape feed stopper 3 and retracting lever stopper (back side of the photo).

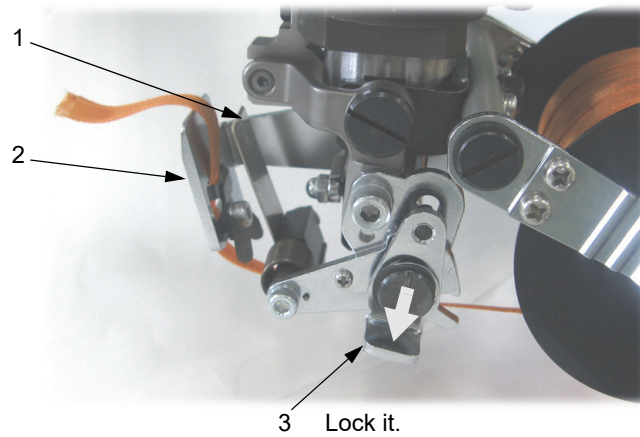

- (3)** When you start the machine by using the bar switch and automatic offset is set to "Yes", the frame will return to the offset start position.



**1st Edition    November, 2009**

**2nd Edition    September, 2021**

■ **Manufactured by : TISM Co.,Ltd.**

Address : NO.1800, Ushiyama-cho, Kasugai, Aichi-pref., 486-0901, Japan

TEL : 81-568-33-1161    FAX : 81-568-33-1191

■ **Distributed by : Tajima Industries Ltd.**

Address : NO.1800, Ushiyama-cho, Kasugai, Aichi-pref., 486-0901, Japan

TEL : 81-568-37-1130    FAX : 81-568-37-1230

●**Copy, reprint, or reform of a part or whole of this manual without permission is prohibited.**