



Optional Device Manual

Auto. PP Tape Feeder

PAR/PAX

Foreword



Thank you for purchasing the TAJIMA embroidery product.

Please read this manual thoroughly, understand the contents, and then use the machine.

This manual may contain discrepancies in detailed specifications when compared with the actual product. If you have any question, please ask the distributor for information.

Safety Precautions and Symbols



Items that require your special attention on handling the machine are specified below.

Description	Meaning
 DANGER	Indicates that there is a lot of danger of death or serious injuries* ¹ .
 WARNING	Indicates that there is a likelihood of death or serious injuries* ¹ .
 CAUTION	Indicates a potentially hazardous situation which may result in minor or moderate injury* ² or physical damage.



*1: A condition caused by electric shock, injury, fracture of a bone etc. that leads to aftereffects, or an injury that necessitates hospitalization or visits to a hospital over a long period.

*2: An injury that does not necessitate hospitalization or visit to a hospital over a long period.

The symbols used throughout this document have the following meanings.

Symbol	Meaning
	Item to be prohibited
	Items that could cause electric shock
	Items to keep safety

Other Precautions

Description	Meaning
	Items that may affect stitching.
	Recommended and useful tips.

Disclaimer, etc.

- The external views and specifications of the machine and the contents of this manual are subject to change without notice due to improvement.
- TAJIMA bears no responsibility regarding any damage arising from not observing the instructions in the manual or any fault or damage resulting from repair, disassembly, or modification not indicated in the manual.
- You may not copy, reproduce, or transcribe a part or whole of this manual without consent of TAJIMA.

Table of contents

1. Name of each part	5
1-1. General drawing	5
2. Preparation	6
2-1. Installing PP tape	6
3. Setting	8
3-1. PP tape feed amount	8
3-2. Various parameters	10
4. Troubleshooting	14
4-1. When the PP tape runs out or cannot be fed	14
4-2. When other errors occur	14
5. Appendix	15
5-1. Converting the boss	15

1. Name of each part

1-1. General drawing

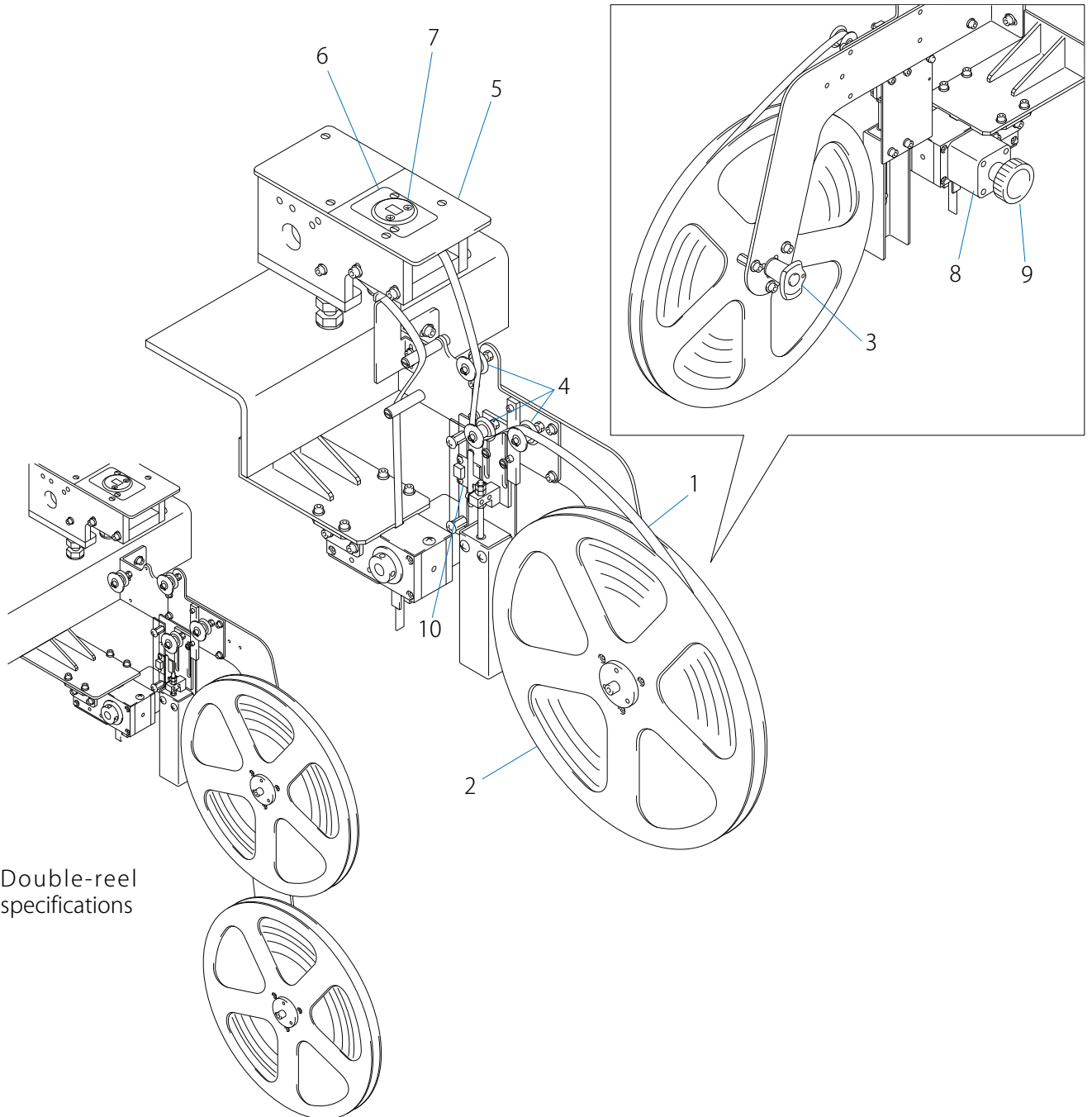

1	PP tape	6	Needle plate
2	Plastic reel	7	Boss
3	Ball lock pin	8	Feed motor
4	Flat pulley	9	Knob
5	Perforator base	10	Sensor card

2. Preparation

2-1. Installing PP tape

⚠ Warning

! To prevent an accident due to an unexpected startup, be sure to turn OFF the power before accessing the machine.

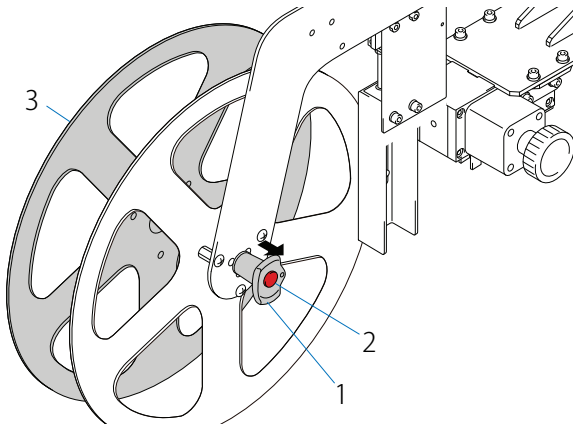

1 Pull out the pin 1 toward you to remove the Plastic reel 3 while pushing the red button 2 of the ball lock pin 1.

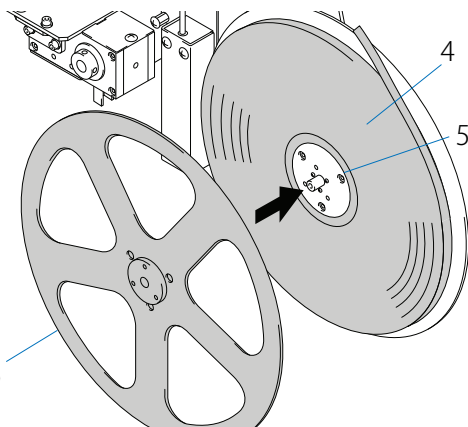

2 Install the PP tape 4 to the reel lid 5 while holding it so that it does not come loose.



- Orient the PP tape as shown in the figure when installing it.



- For the double-reel specifications, install the 0.5-mm tape to the upper side and the 0.3-mm tape to the lower side.

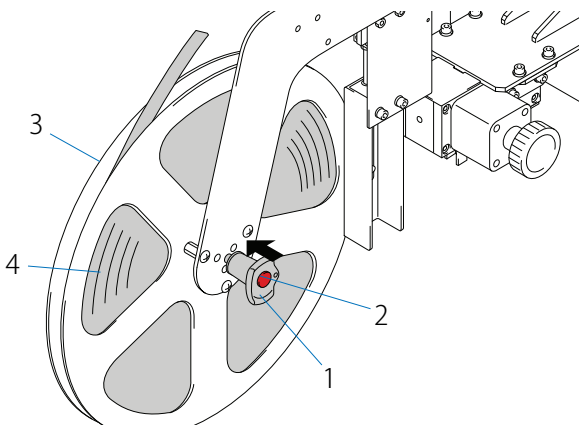

3 Install the Plastic reel 3 while pushing the red button 2 of the ball lock pin 1, and push in the pin.



- Turn the Plastic reel until its hole aligns with the protrusion on the reel lid. When they align with each other, the Plastic reel engages with a click sound.

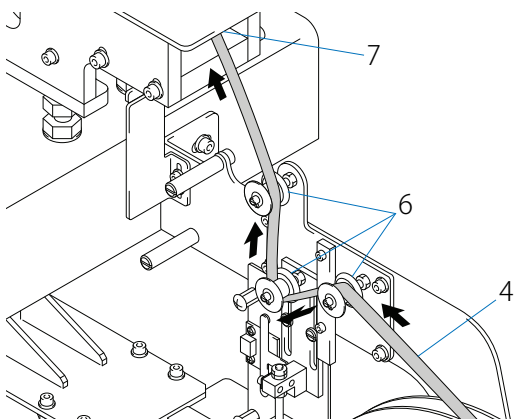

- As shown in the figure, pass the PP tape 4 through the flat pulley 6 and guide it to the underside of the perforator base 7.



- Lead the PP tape with no twist.

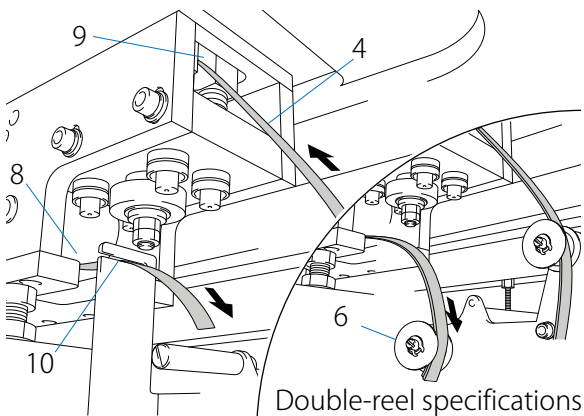

- Feed the PP tape 4 into the inlet 9 until the tip of the PP tape 4 comes out of the tape outlet 8.

- Lead the tip of the PP tape 4 through the slit 10.



- No plate is provided for the slit 10 in the case of the double-reel specifications. Pass the tape through the flat pulley 6 and guide it to the inlet 11 of the feed motor.

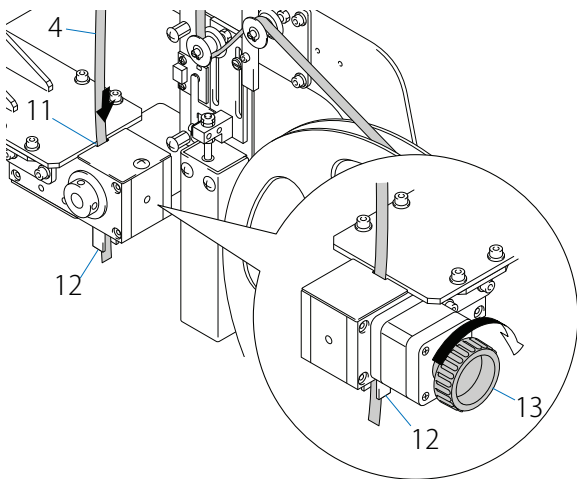

- Lead the PP tape 4 to the PP tape inlet 11 of the feed motor.

- Turn clockwise the knob 13 of the feed motor until the tip of the PP tape 4 comes several centimeters out of the outlet 12.

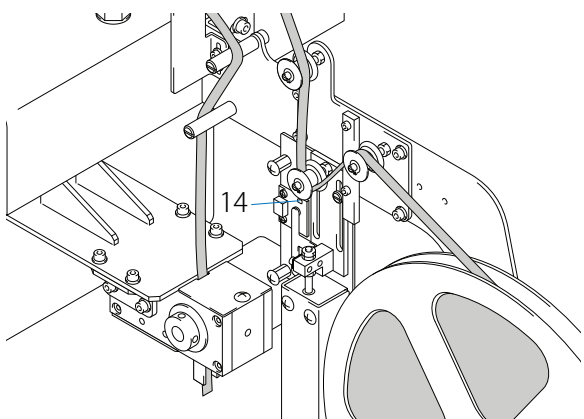

- Turn ON the power.
At this time, check that the error lamp 14 of the sensor card is not lit in red.



- If the sensor card error lamp is lit in red, adjust the PP tape tension because it means that the tension is high or low.
- Once the error lamp lights up, the machine stops with a code number displayed on the screen.

3. Setting

3-1. PP tape feed amount

Adjust the tape feed amount as needed depending on the fabric type and thickness and the desired cut finish. Use the operation panel to adjust the feed amount.



- To display parameters P7 and P8, it is necessary to enter the password and change the functional limit level. Refer to the PAX and PAR User's Manuals.

■ Adjusting the PP tape feed amount for all the perforator needles at once

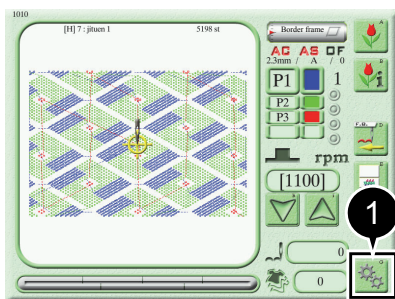

1 Press  on the main screen.

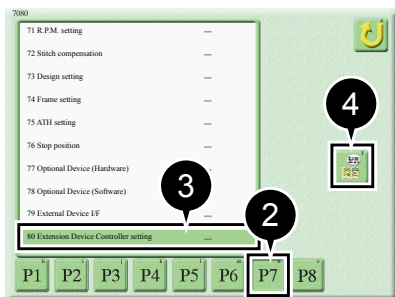

2 Press .

3 Select [80. Extension Device Controller setting].



- If the [80. Extension Device Controller setting] item is missing, register your extension device controller. For information on how to do so, refer to “3-2. Various parameters”.

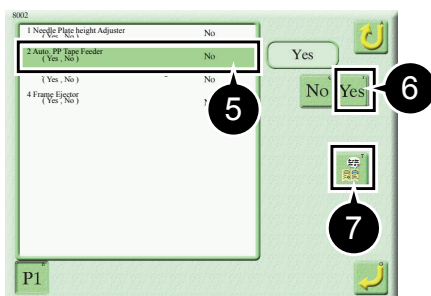

4 Press .



5 Select [2. Auto. PP Tape Feeder].

6 Press .

 is displayed on the screen.

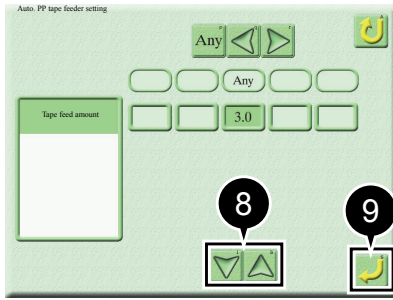
7 Press .



8 Press   to adjust the PP tape feed amount.



- You can set the PP tape feed amount within the range of 0.1 to 3.0 mm.



9 Press .

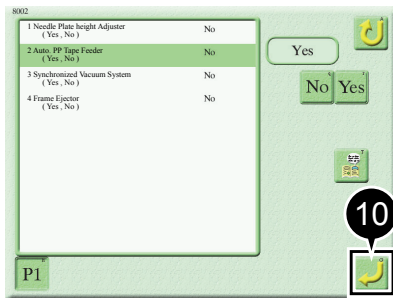

10 Press .

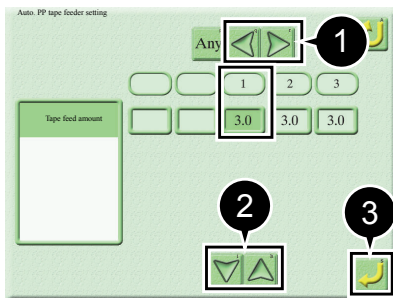

■ Adjusting the feed amount for each perforator needle





1 Press   to place the desired perforator needle number in the center.

2 Press   to adjust the PP tape feed amount.

3 Press .



- You can set the PP tape feed amount within the range of 0.1 to 3.0 mm.
- Press  and then  to reset the value you set for each perforator needle.

4 Press .

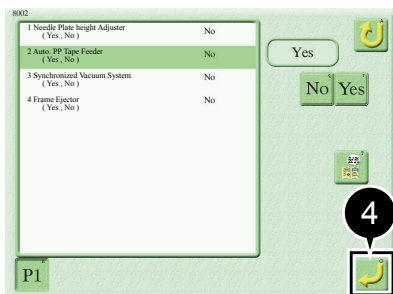

3-2. Various parameters

The following parameters are configured at shipment. Therefore, under normal circumstances, you do not have to change these settings.

Change these settings, however, when you add the Auto. PP Tape Feeder. You cannot use the Auto. PP Tape Feeder unless you correctly set the parameters associated with the Auto. PP Tape Feeder.



- You do not have to change the settings after software installation.

■ External Device Interface

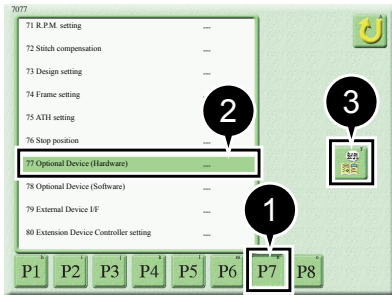

- 1 Press **P7** on the parameter screen.
- 2 Select [77. Optional Device (Hardware)].
- 3 Press **P7**.

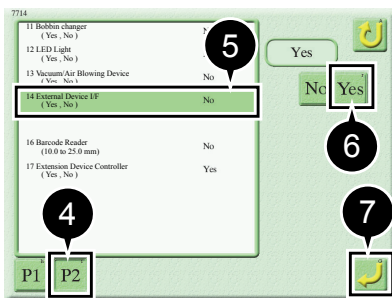

- 4 Press **P2**.
- 5 Select [14. External Device I/F].
- 6 Press **Yes**.
- 7 Press **P2**.

Extension Device Controller



- If the Extension Device Controller is not set to **Yes**, you cannot check the presence of the Auto. PP Tape Feeder or adjust the PP tape feed amount.

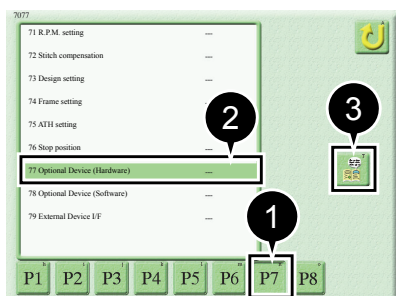

- Press **P7** on the parameter screen.
- Select [77. Optional Device (Hardware)].
- Press **Yes**.

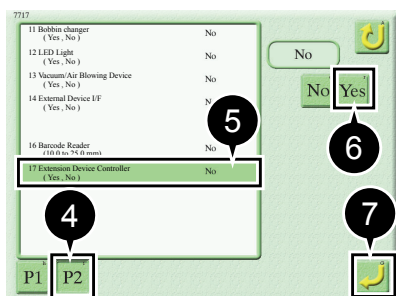

- Press **P2**.
- Select [17. Extension Device Controller].
- Press **Yes**.
- Press **Yes**.

Auto. PP Tape Feeder

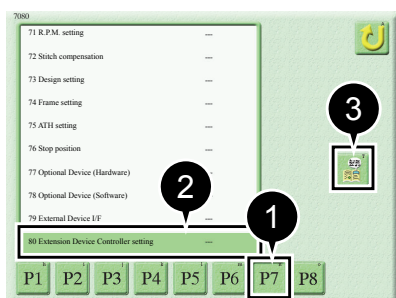

- Press **P7** on the parameter screen.
- Select [80. Extension Device Controller setting].
- Press **Yes**.

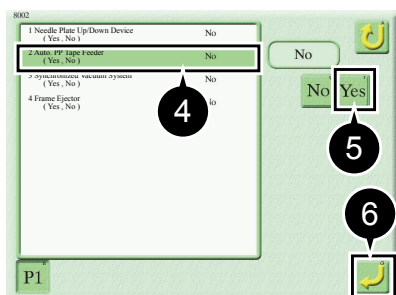

- Select [2. Auto. PP Tape Feeder].
- Press **Yes**.
- Press **Yes**.

■ 5V external input

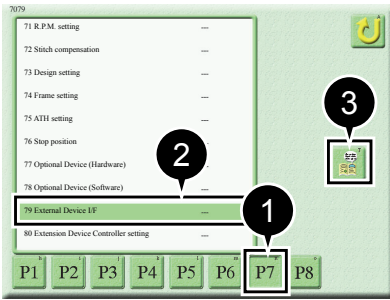

1 Press **P7** on the parameter screen.

2 Select [79. External Device I/F].

3 Press .

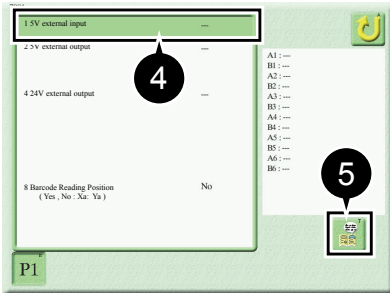

4 Select [1. 5V external input].

5 Press .

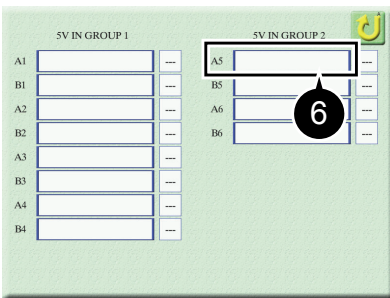

6 Select [A5].

 • Select the same port number as the port connected to the terminal base of the machine.

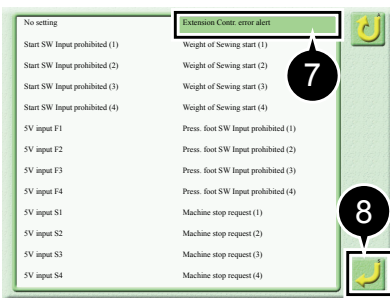

7 Select [Extension Contr. error alert].

8 Press .

24V external output

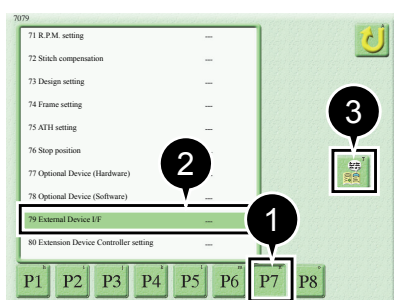

1 Press **P7** on the parameter screen.

2 Select [79. External Device I/F].

3 Press .



4 Select [24V External Output].

5 Press .

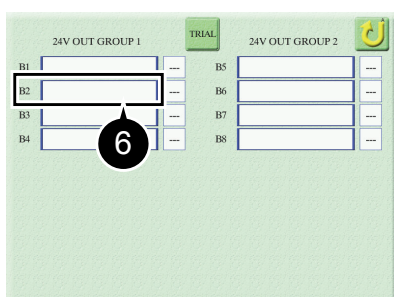

6 Select [B2].



- Select the same port number as the port connected to the terminal base of the machine.

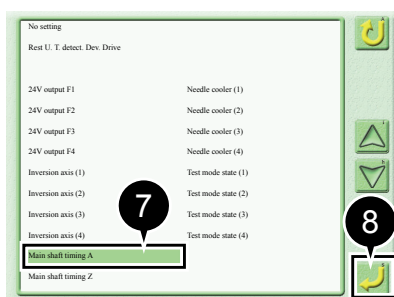

7 Select [Main Shaft Timing A].

8 Press .

9 Similarly, register [Main Shaft Timing Z] to [B3].

4. Troubleshooting

4-1. When the PP tape runs out or cannot be fed

The machine stops with the code number 237 displayed on the screen.

Remove the cause of the error and press  to clear the error.

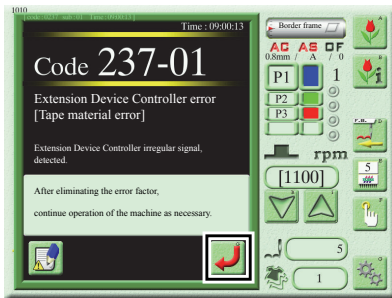

Cord	Stop factor	Troubleshooting
237	Running out of material detected All the PP tape material has been used up.	Install new PP tape. For information on how to install PP tape, refer to "2-1. Installing PP tape".

4-2. When other errors occur

The machine stops with the code number 334 displayed on the screen.

Turn OFF the power. Wait for 30 or more seconds and then turn ON the power.

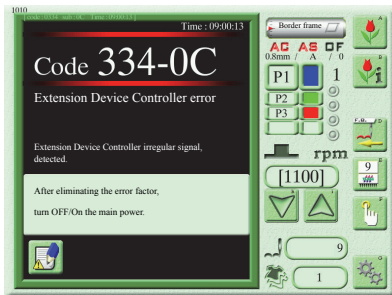

Caution

 Before you turn ON the power again, wait for 30 seconds or more. Otherwise the system may fail to start up normally.



- If the error cannot be cleared, consult the distributor.

5. Appendix

5-1. Converting the boss

Before you use PP sheet, replace the boss with the boss for PP sheet.

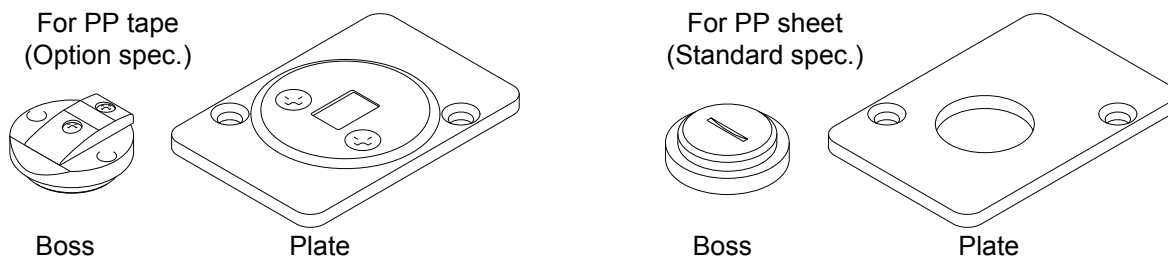

- For more information on how to use PP sheet, refer to the user's manual for the machine.

Warning

- ! To prevent an accident due to an unexpected startup, be sure to turn OFF the power before accessing the machine.

■ Conversion from the boss for PP sheet to the boss for PP tape

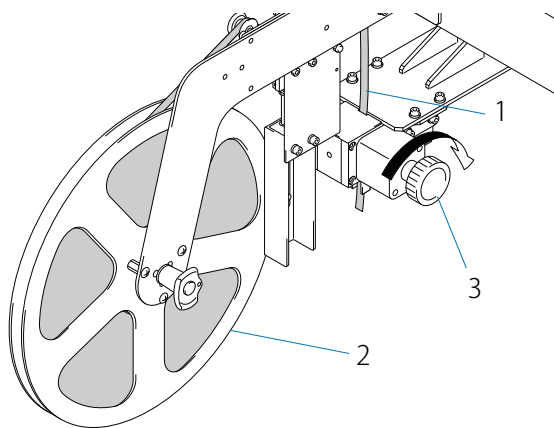

- 1 Remove the PP sheet.
- 2 Set the Plastic reel 2 and lead the PP tape 1 to the feed motor.
- 3 Turn the knob 3 of the feed motor clockwise to pull out the PP tape 1 several centimeters from the outlet.

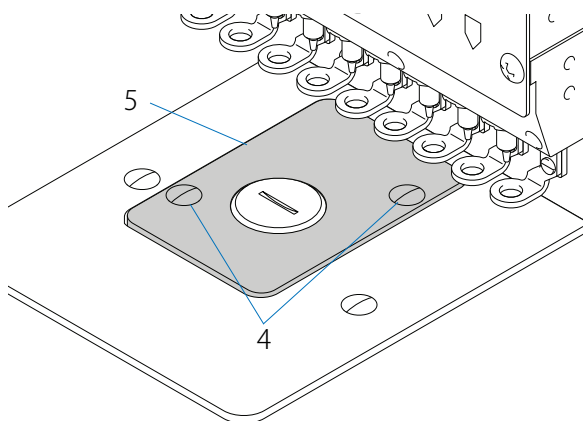

- 4 Remove the screws 4. Then remove the plate 5 for the PP sheet.

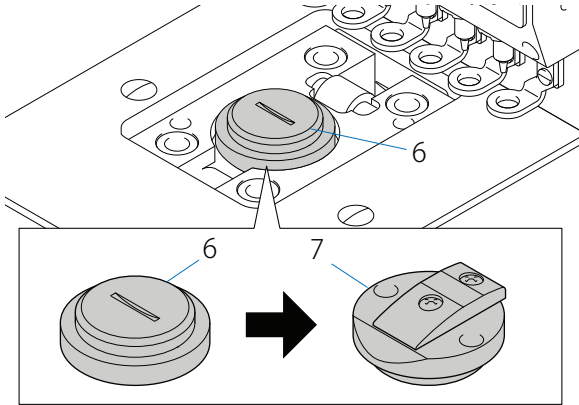

5 Replace the boss 6 for the PP sheet with the boss 7 for the PP tape.



- When replacing bosses, do not mistake the front-back direction of the boss.

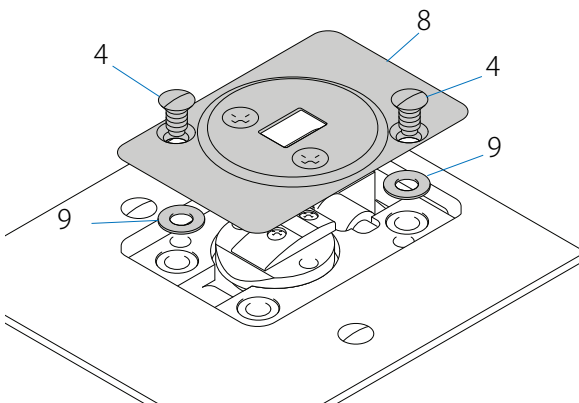

6 Install the plate 8 for the PP tape and tighten the screws 4.



- For the double-reel specifications, insert the 0.5-mm washers 9 under the plate 8 and tighten the screws 4.

■ Conversion from the boss for PP tape to the boss for PP sheet

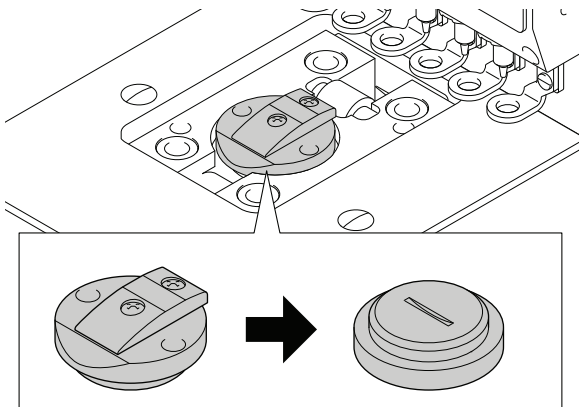

1 Convert the boss in the same procedure as "Conversion from the boss for the PP sheet to the boss for the PP tape".

2 Wind the PP tape on the reel.

1st edition September 2018

3rd edition May 2021

■ **Manufactured by : TISM Co.,Ltd.**

Address : NO.1800, Ushiyama-cho, Kasugai, Aichi-pref., 486-0901, Japan

TEL : 81-568-33-1161 FAX : 81-568-33-1191

■ **Distributed by : Tajima Industries Ltd.**

Address : NO.1800, Ushiyama-cho, Kasugai, Aichi-pref., 486-0901, Japan

TEL : 81-568-37-1130 FAX : 81-568-37-1230

●**Copy, reprint, or reform of a part or whole of this manual without permission is prohibited.**