

# ***MACHINE SETUP INSTRUCTIONS***

---

## ***TMCP-VF***

### **[IMPORTANT]**

**To handle the machine correctly and safely,  
perform operations according to the procedure  
described in this manual.**



# User's Manual / Parts List

User's manual / Parts list are stored as the PDF file in the accessory DVD.

Please read the contents thoroughly and then use the machine or the optional device.

To see the PDF file, "Adobe Acrobat Reader" is necessary.

User's manual, parts list of the optional devices you have not purchased are included in this DVD.  
Please note beforehand.

## [How to open the DVD]

1. Insert a DVD into the personal computer.



Since the following pop-up window will be displayed automatically, select "Open folder to view files" (indicated by the arrow).

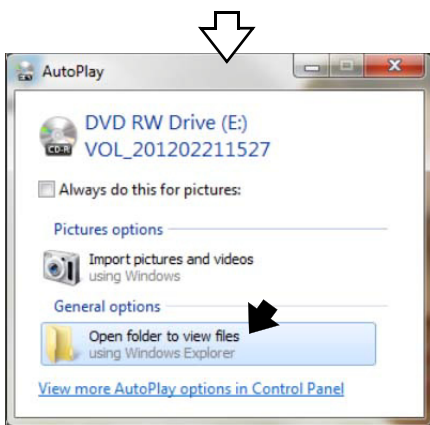

2. Double-click left "titlepage".

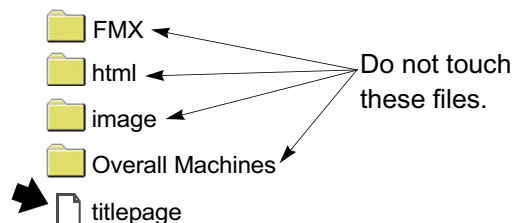

3. Select displaying language.



4. Select "User's Manual" or "Parts List", and then select the title you desire.



The figure above is an example selecting "English (Multiple Languages)" in the above 3.

## Foreword

This manual introduces the procedure for setup of TAJIMA embroidery machine TMCP-VF.  
Please understand the contents, and then use the machine.

The contents of this manual may contain discrepancies in detailed information when compared with the actual product.  
If any question about the products or contents of this manual arises, please consult your TAJIMA distributor.

Regarding optional device, refer to the user's manual (separate volume) of the device.

Please keep this manual with care near the machine for quick reference.

**TISM Co.,Ltd.**

## SAFETY PRECAUTIONS

To prevent any harm or damage to the person who use this product or other person, we describe items that must be surely followed as below.



Indicates that there is a lot of danger of death or serious injuries [\*1] if handled by mistake.



Indicates that there is a likelihood of death or serious injuries [\*1] if handled by mistake.





Indicates a potentially hazardous situation which may result in minor or moderate injury [\*2] or property damage if handled by mistake.

\*1: A condition caused by electric shock, injury, fracture of a bone, etc., that leads to aftereffects, or an injury that necessitates hospitalization or visits to a hospital over a long period.

\*2: An injury that does not necessitate hospitalization or visit to a hospital over a long period.

 : Prohibited items

 : Items that may cause electric shock if not observed

 : Items that must be followed carefully to ensure safe operation





## MUST DO LIST AT MACHINE INSTALLATION

MODEL:	M/NO.:
	DATE     /     /     /     PIC:

Check the following items in order after “Chapter 5 Level adjustment”.

Chapter 6 Adjustments	Remarks	✓
1. Needle locating position	Check and adjust the needle locating position. <ul style="list-style-type: none"> <li>The 1st needle on all heads</li> <li>The last needle on all heads</li> </ul> Equalize it at the 1st needle and the last needle.	✓
2. Lower dead point	Check and adjust the lower dead point.	✓
3. Upper dead point	Check and adjust the upper dead point.	✓
4. Bevel gear	Check and adjust bevel gears gap in front/rear, left/right direction.	✓
5. Needle and rotary hook	Check and adjust the needle and the rotary hook timing and the gap.	✓

Chapter 7 Idling and test sewing	Remarks	✓
1. Lubrication	Lubricate to the rotary hook and the inside of the arm.	✓
2. Idling, jump	Run the machine at least 20 minutes without threads for all needles to remove anti-rust liquid from the rotary hook.	✓
	Check if the reciprocator catches the needle bar stud at inching.	✓
	Check if the jump device operates properly.	✓
3. Threader	Pass thread correctly.	✓
4. Test sewing	Check if the thread breakage or the needle breakage occurs.	✓

## Chapter 1 Carrying

1.	Installation environment.....	1
2.	How to carry.....	3
2-1.	When using a crane.....	3
2-2.	When using a forklift.....	5
3.	Installation.....	6
3-1.	Vibration-preventive base.....	6
3-2.	Anti-vibration stand.....	7

## Chapter 2 Detaching, attaching

1.	Detaching.....	9
1-1.	Stopper.....	9
2.	Attaching.....	10
2-1.	X-axis drive system (Y-emb. space 1200 mm or more).....	10
2-2.	Front table and bar switch (option).....	14
2-3.	Table support (Y-emb. space 750 mm or more).....	16
2-4.	Attaching of border frame.....	17
2-5.	Thread course.....	19
2-6.	Operation panel.....	20
2-7.	Beam sensor (limited model).....	22

## Chapter 3 Connection of power cord

1.	Important safety instructions.....	23
----	------------------------------------	----

## Chapter 4 Operation panel settings

1.	Parameter setting.....	25
2.	Absolute origin search.....	26

## Chapter 5 Level adjustment

1.	How to use level gauge.....	27
2.	Level adjustment.....	29
3.	Center support.....	30

## Chapter 6 Adjustments

<b>1.</b>	Needle locating position .....	34
<b>2.</b>	Lower dead point .....	37
<b>3.</b>	Upper dead point .....	41
<b>4.</b>	Bevel gear .....	43
<b>5.</b>	Needle and rotary hook .....	44

## Chapter 7 Idling and test sewing

<b>1.</b>	Lubrication .....	45
<b>1-1.</b>	Rotary hook .....	45
<b>1-2.</b>	Inside of arm .....	46
<b>2.</b>	Idling, jump .....	47
<b>3.</b>	Threader .....	48
<b>4.</b>	Test sewing .....	51



# Chapter 1 Carrying

## 1. Installation environment

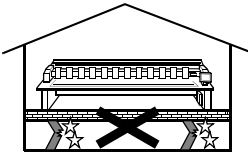

**CAUTION**

-  Install the machine on a sturdy floor.

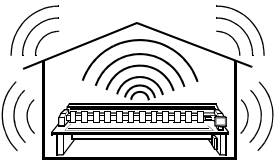

The floor structure must be strong enough to bear the machine weight (indicated on the spec. plate). If the floor is supported by steel frames, place the machine stand on the steel beams as long as possible.

-  Control the operation noise in the environment.

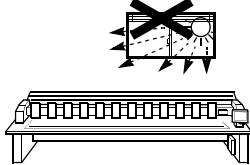

This machine is designed to reduce noise during operation. To improve the sound insulation performance in the factory still more, use the interior finish materials which show high sound insulating performance for the walls, ceiling, and floor of the factory.

-  Avoid direct sunlight.

If the machine is exposed to direct sunlight over an extended period of time, the machine body may be discolored or deformed. Put curtains or shades to the sight to prevent the machine from direct sunlight.

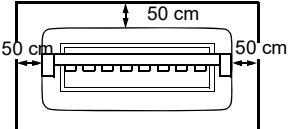

-  Provide enough space for maintenance.

Taking account of workability when maintaining and inspecting the machine, provide working space of 50 cm or more to right and left, and to 50 cm or more to rear direction for the machine against obstacles such as walls.

-  Avoid dust and moisture.

Since dust and moisture lead to dirt and rust on the machine, use the machine in an environment of facility of air conditioner, and clean the working place periodically. Use caution not to expose the machine to direct wind from the air conditioner so that embroidery threads do not become disheveled.

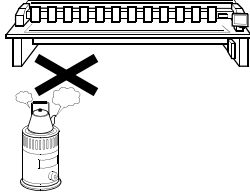
Degree of pollution: 2 or less  
 Humidity: 30 to 95%RH (relative humidity) without condensation  
 Ambient temperature: 5 to 40°C (during operation), -10 to 60°C (during storage)



**CAUTION**

- ! Pay attention to interference of radio wave.

Although the machine is designed not to apply radio wave to other equipment, there could be cases where it causes radio wave interference depending on operation environment and type of equipment. If such problems arise, install the equipment as apart from the machine as possible.

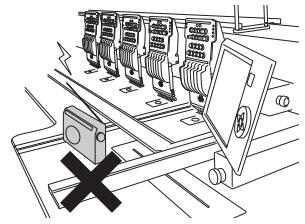

- ! Pay attention to power supply style.

When supplying the power, meet the following requirement.

- Excess voltage category: III

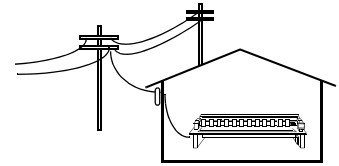

## 2. How to carry

### 2-1. When using a crane

#### DANGER

- ! When suspending (lifting) the machine, make sure that there is no person standing in the danger area around the machine, especially under the machine.

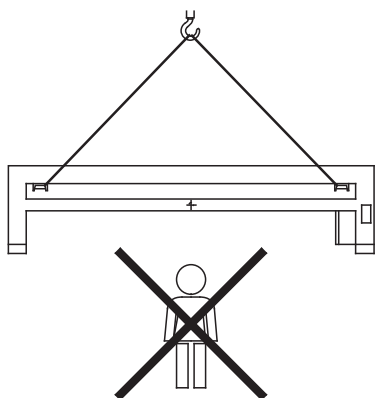

#### WARNING

- ! When suspending the machine, attach the anti-come-off bolts so that the nylon slings do not come off.

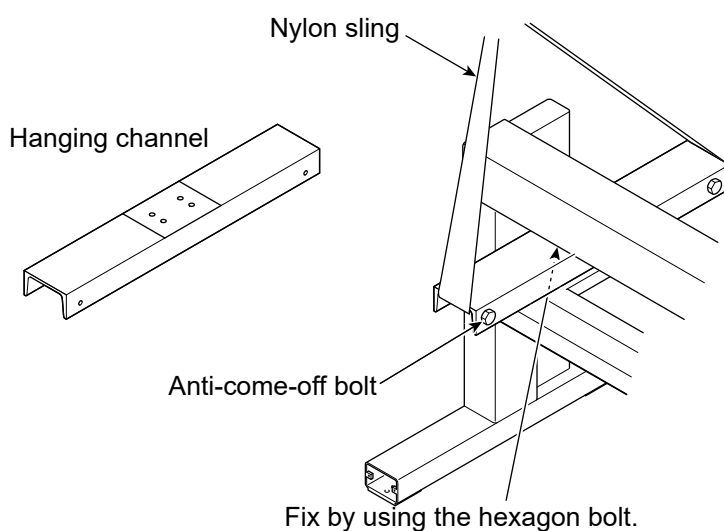

**! WARNING**

**!** When suspending the machine, use a nylon sling that is long enough to provide a sling angle of 50° or more.

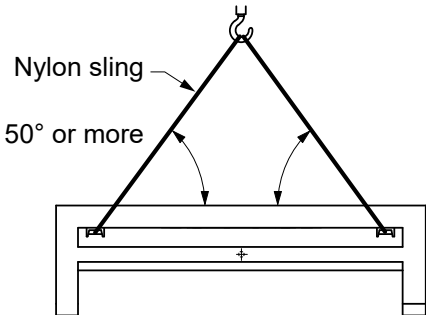

## 2-2. When using a forklift

**! DANGER**

**!** To lift the machine, check if there is no person around the dangerous zone of the machine, especially below the machine. Then, start working.

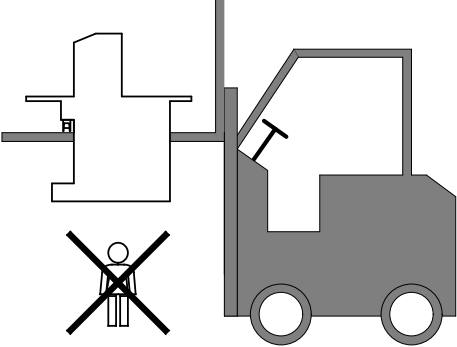

**! WARNING**

**!** When you use a forklift, pay enough attention not to drop the machine. Move the forklift to lift the machine with reference to "Gravity center mark" that shows right and left balance of the machine.

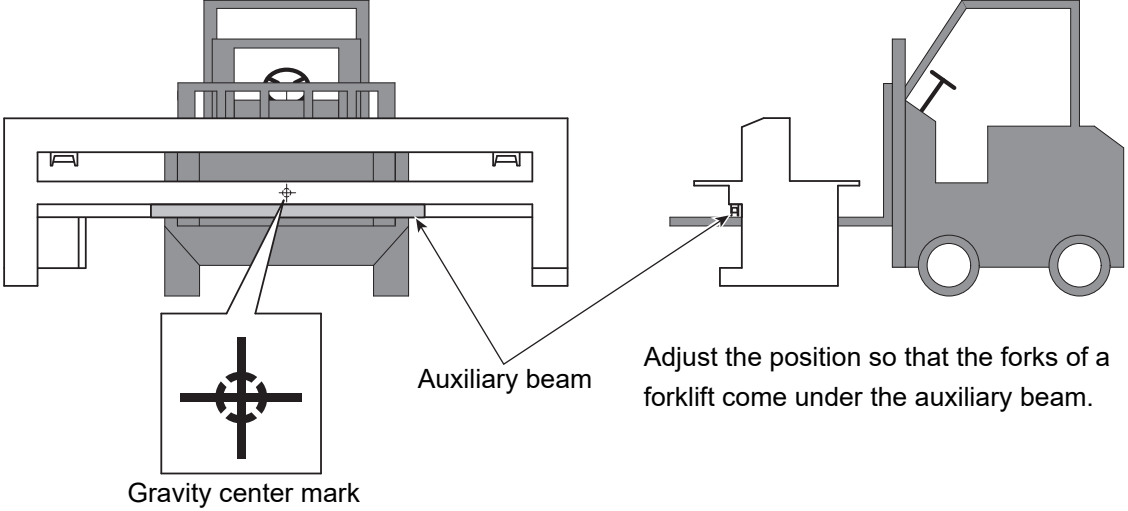

Auxiliary beam

Gravity center mark

Adjust the position so that the forks of a forklift come under the auxiliary beam.

### 3. Installation

## ! WARNING

! Workers should understand the procedure thoroughly, and then start working. Unexpected action could cause injury.

#### 3-1. Vibration-preventive base

- (1) Put the square lumbers 1 of about 3 cm thick and vibration-preventive bases 2 on the installation site, and put the machine once on them.
- (2) Set the hexagon bolt 3 and the nut 4 in the stand, and screw them until the machine is lifted.
- (3) Remove the square lumber 1.

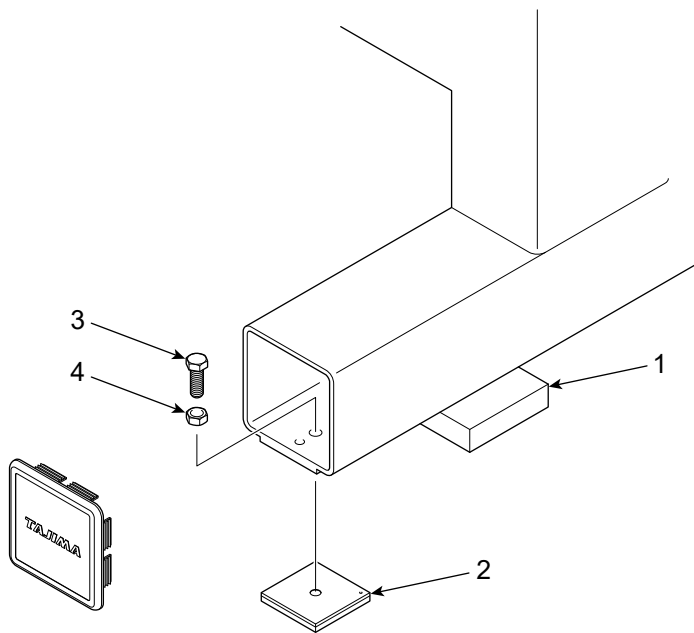

### 3-2. Anti-vibration stand

This work is supported only for the machine model in which the anti-vibration stand is packed.

Anti-vibration stand

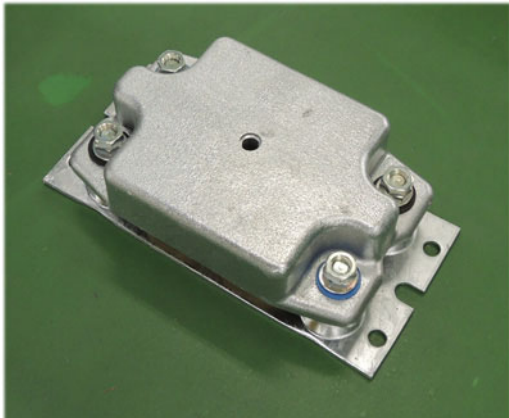



**CAUTION**

 There are two types of anti-vibration stand, for the front side and for the back side. Therefore, do not mistake. Otherwise, trouble like thread breakage could occur.

Attaching position becomes opposite from back to front according to Y-axis embroidery space. Attach the anti-vibration stand to the correct position referring to the chart below. The type of the anti-vibration stand contained in the package differs depending on the model.

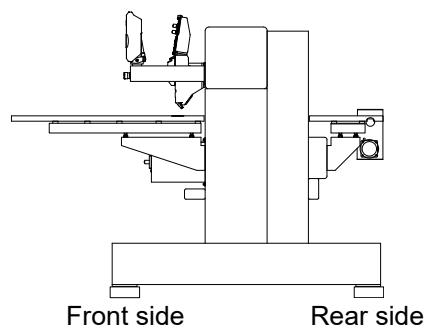
Y-axis embroidery space	Anti-vibration stand
679 mm or less	Front side: BU-1000TMA Rear side: BU-1250TMA or Front side: BU-1250TMA Rear side: BU-2000TMA
680 mm or more	Front side: BU-1250TMA Rear side: BU-1000TMA or Front side: BU-2000TMA Rear side: BU-1250TMA



- (1)** Make the tip of the adjusting bolt 1 come out 15 mm from the bottom of the stand and set the anti-vibration stand 3 to the position where the adjusting bolt 1 enters to the hole 2 for the anti-vibration stand bolt 2. Perform adjustment again so that it becomes possible to push the resin bushing 5 along the stopper bolt 4 into the anti-vibration stand 3. After that, set the nut 6 and tighten the nut of the adjusting bolt 1.

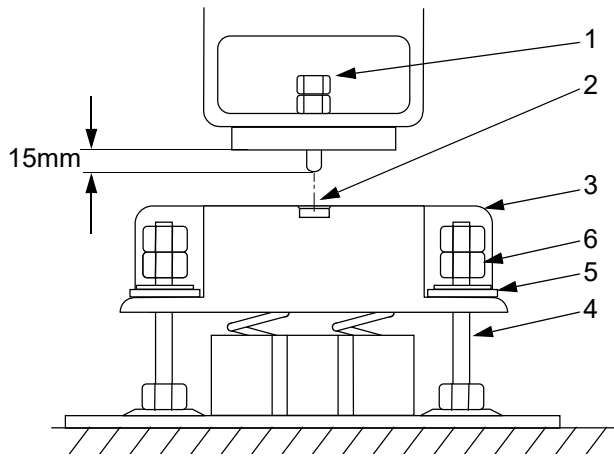

For details of adjustment, please ask the distributor about information.

- (2)** Adjust the position of the nut so that the clearance between the nut and the washer (the clearance between the washer and the vibration-preventive base) becomes 1 mm. Tighten each nut temporarily until the last leveling.

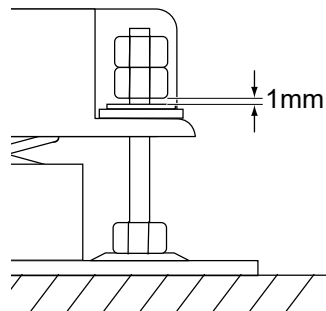

# Chapter 2 Detaching, attaching

## 1. Detaching

### 1-1. Stopper

Attaching position differs depending on model.

Detach all main shaft covers 1 at the beginning, and check attaching positions of the stopper 2 and 3.

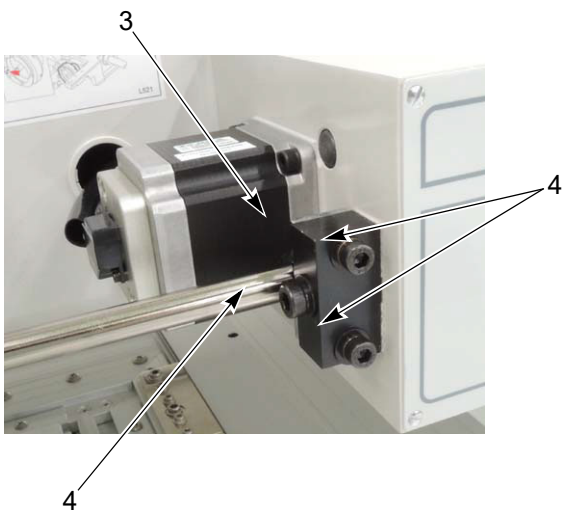
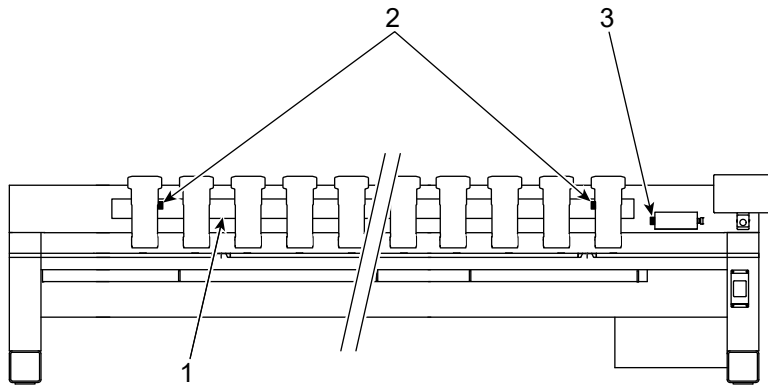

Remove screws 4, and detach the stopper 3.

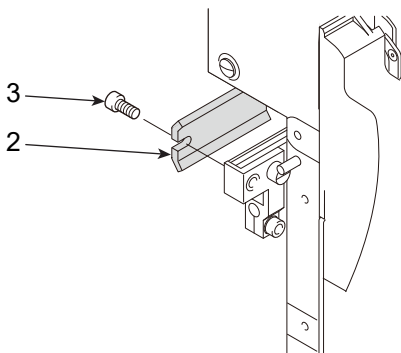

Remove the screw 3, and detach the stopper 2.



## 2. Attaching

### 2-1. X-axis drive system (Y-emb. space 1200 mm or more)

Attach X-axis drive system that is packed separately to the machine and pass the belt.  
The following is how to attach the drive system for the Y-axis 1200 mm spec.

Photo after attaching X-axis drive system (An example of Y-emb. space 1200 mm)

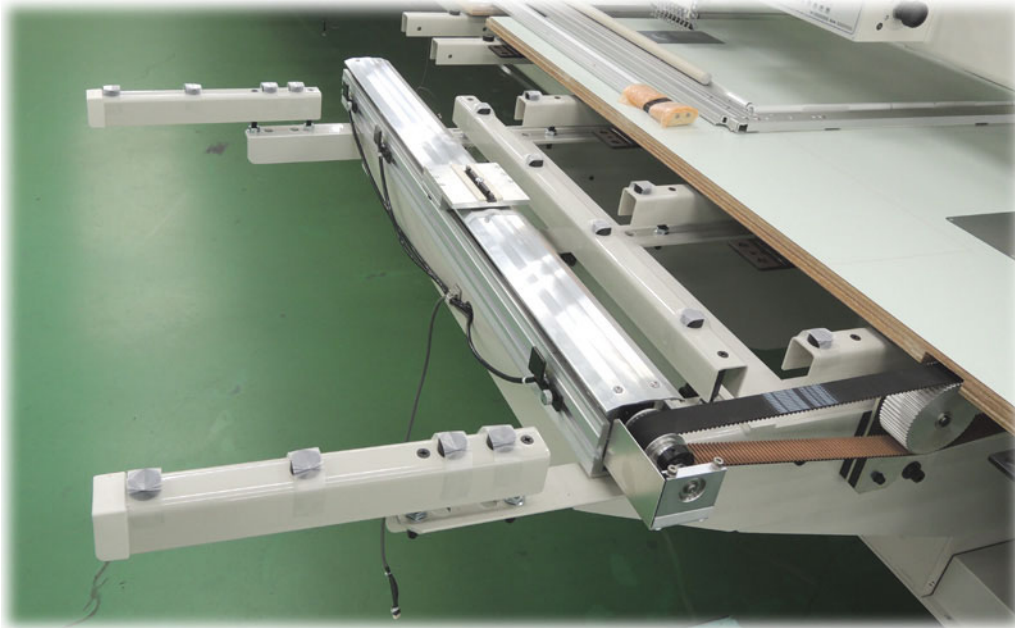

(1) Remove screws 1 (two pieces), and detach the bearing case 2.

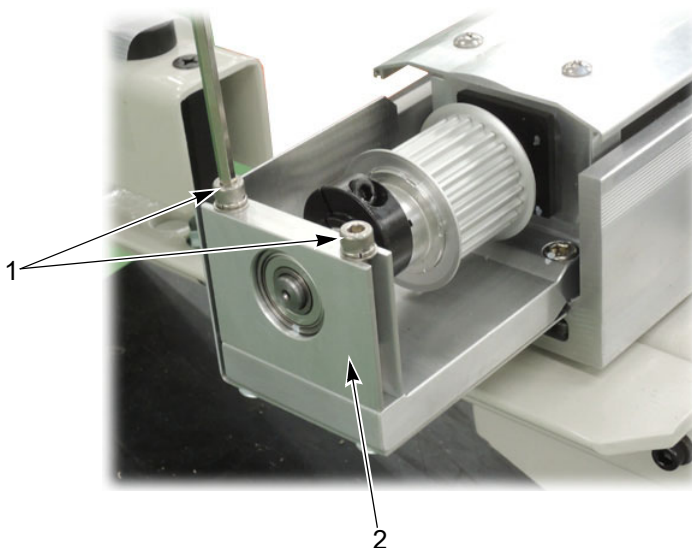

(2) Hook the timing belt 3 on the timing pulley 4, and fix X-axis drive system 5 to the machine.

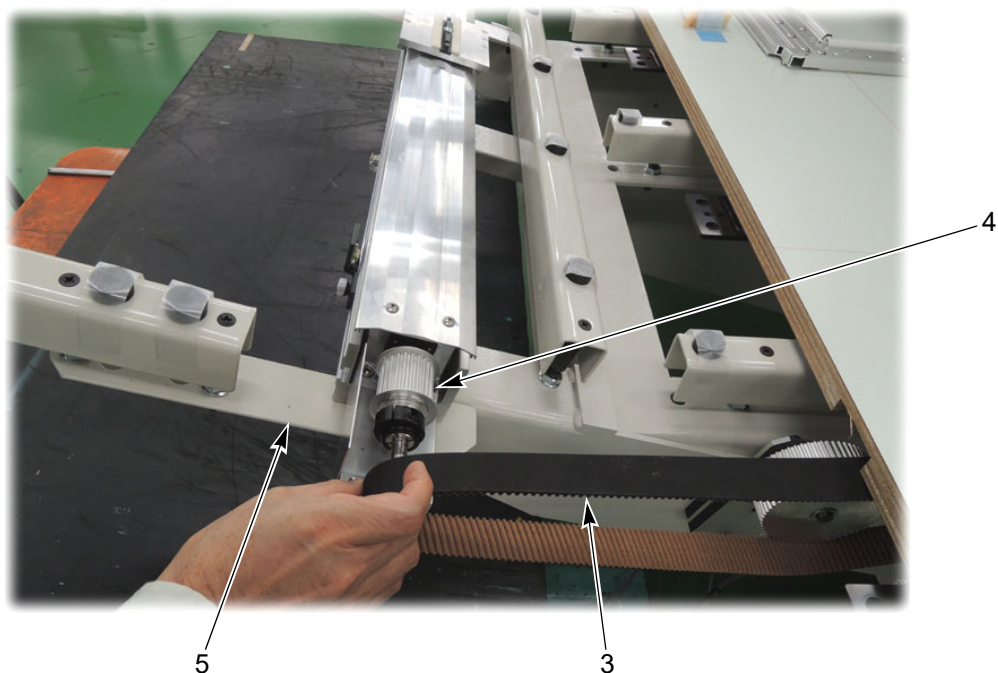

[Fixing spots (indicated by circles) of X-axis drive system 5]

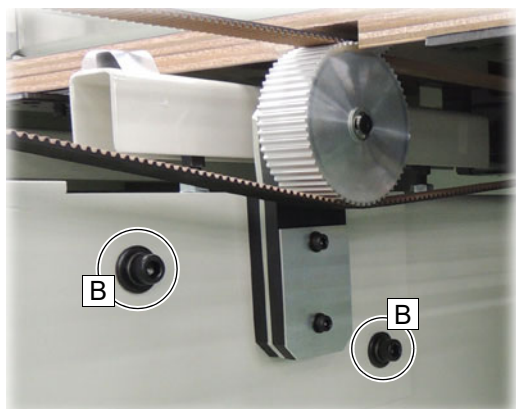
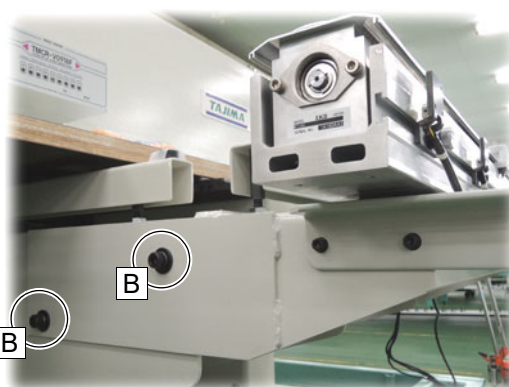
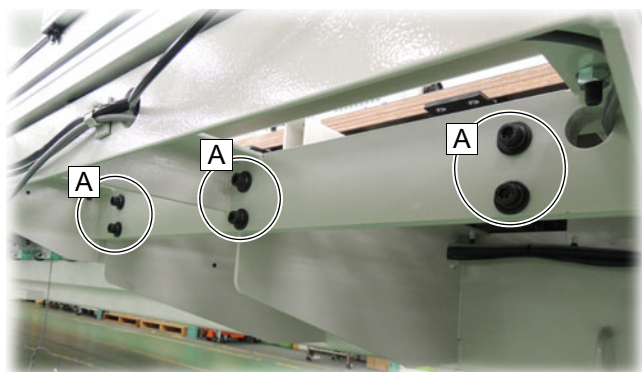

Hexagon socket head cap screws at position A and B in the photo are different in length.

- A** Hexagon socket head cap screw (M10\*30), spring washer (M10), large thick washer (M10)
- B** Hexagon socket head cap screw (M10\*20), spring washer (M10), large thick washer (M10)

**(3)** Fix the bearing case 2 by using screws 1.

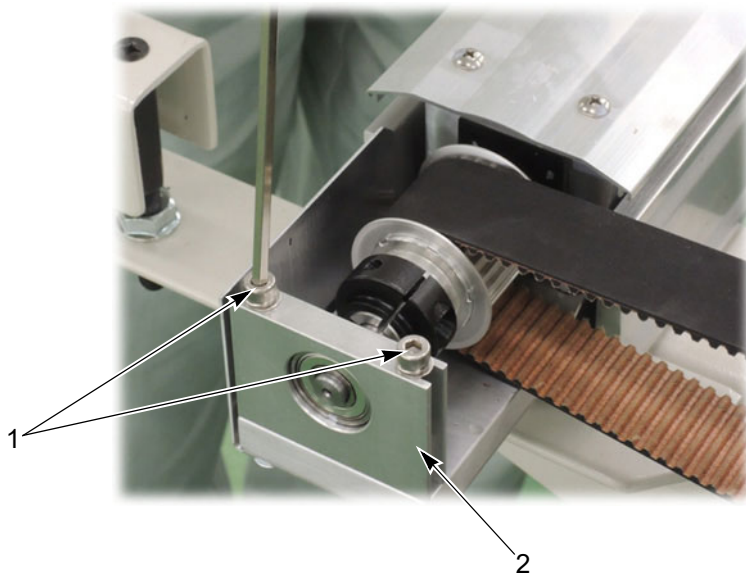

**(4)** For Y-axis 1200 mm spec. only, attach the timing pulley set 6 to the machine by using screws 7.

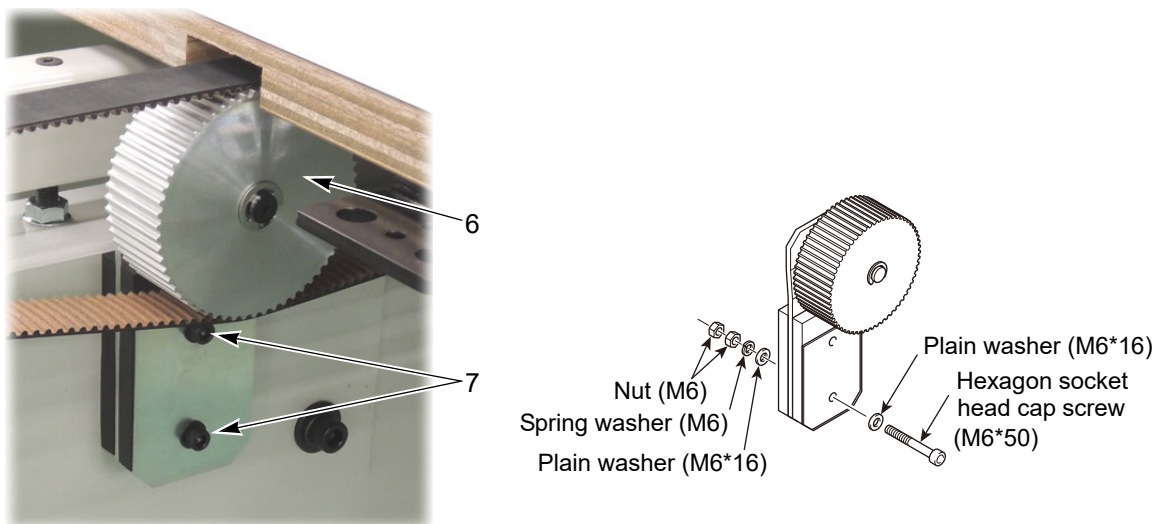

**(5)** Remove the screw 8. The screw 8 will not be used.

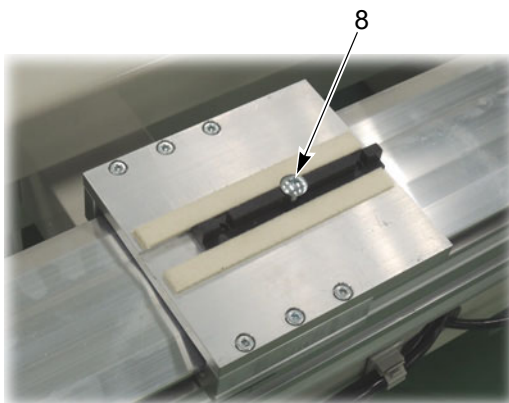

(6) Pass the magnetic sensor harnesses 9 through the hole 10 of the drive system base.

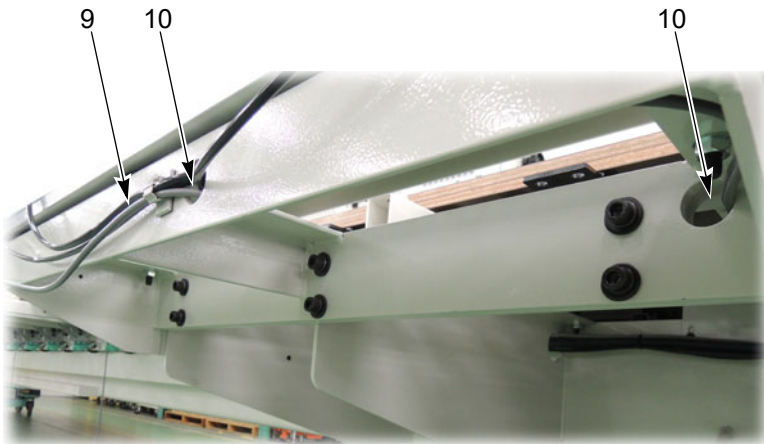

(7) Attach the magnetic sensor harnesses 9 to the magnetic sensor cards 11, 12, and 13.

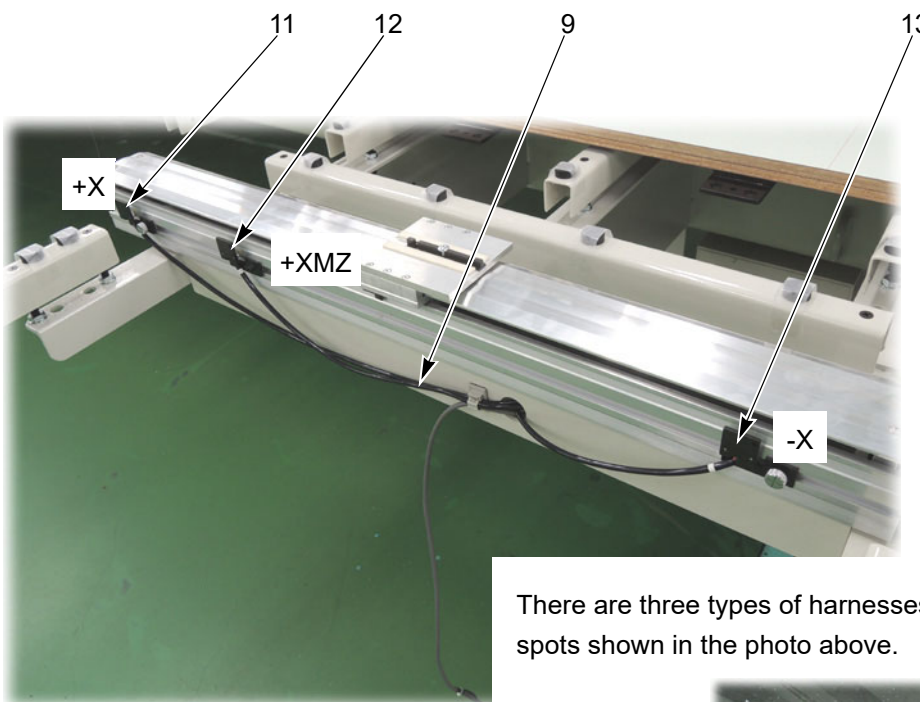

There are three types of harnesses, so connect them to the spots shown in the photo above.

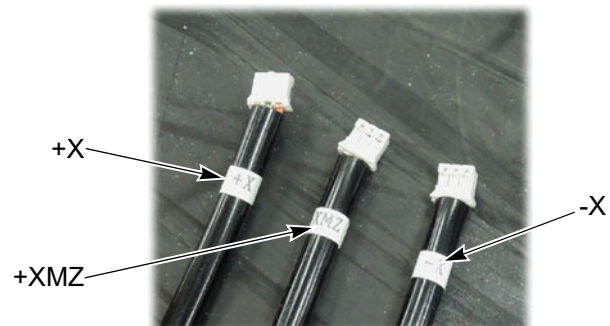

## 2-2. Front table and bar switch (option)

This work is supported only for the machine model in which the front table is packed.

- (1) Attach the front table packed with the machine.

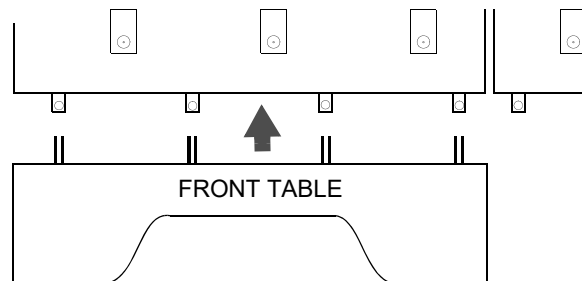

- (2) Tighten the table aligning plate by using the hexagon socket head cap screw.



- (3) Fix the table holder from the side by using the button screw and tighten the wood screw from the back. Use the hole for wood screw at the backside of the front table.

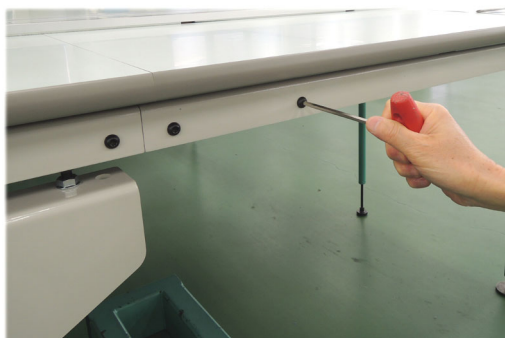

**(4)** Attach the bar switch by using the wood screw.

Use the hole for wood screw at the back side of the front table as the attaching position.

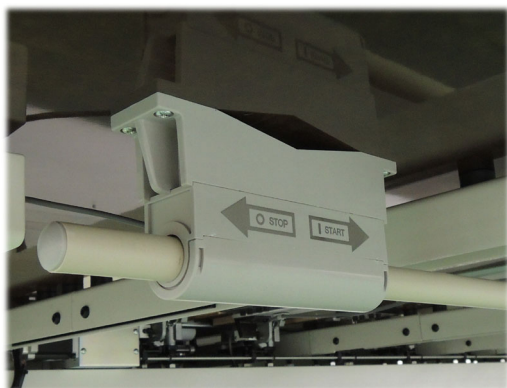

### 2-3. Table support (Y-emb. space 750 mm or more)

Fix the table support (packed with the machine) under the table. Screw holes or nuts are embedded under the table at fixing spots (Fixing spots differ depending spec. of the machine).

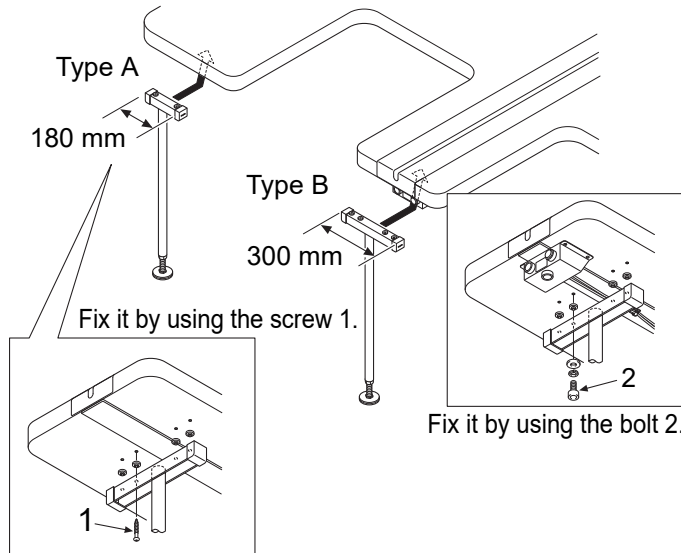

Fixing nut (for type B)

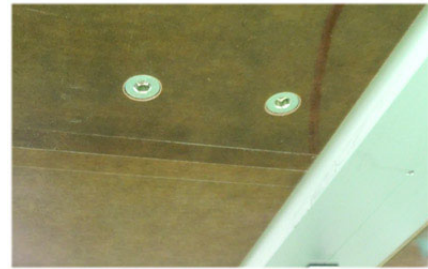

Put the table support on the floor, and adjust the height by using the adjusting bolt 3, then fix by using the bolt 4 (in the same way as type A and B).

An example of fixing spot

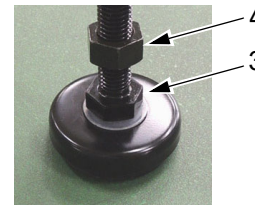
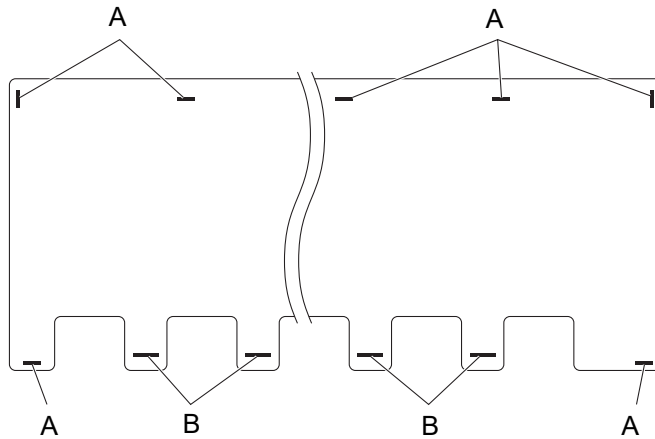

## 2-4. Attaching of border frame

The target models are the machines with table cut type C3, C4, C5 or C9 specified (but the front table is detached at shipment in the factory).

- (1) Attach the border frame 3 so that three pieces of bearing 1 comes into the groove 2 of the sash.

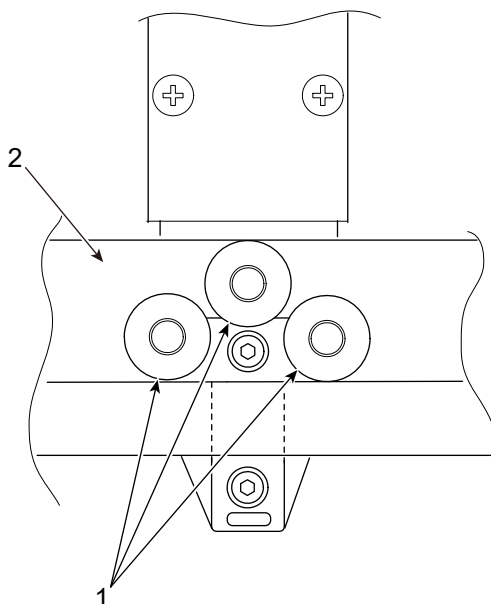
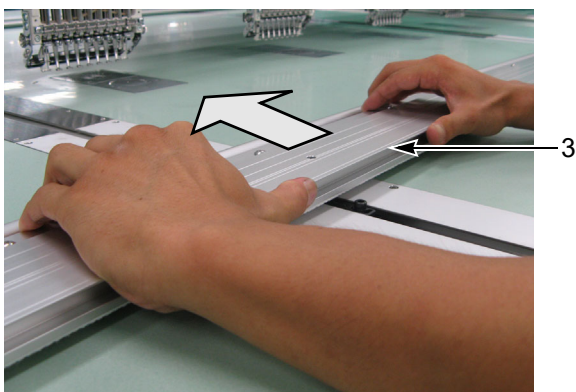

- (2) Align the wrench passing hole 4 of the border frame 3 with the center of the front rail.

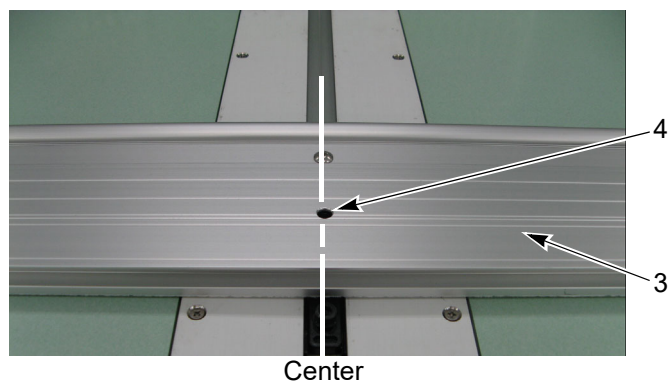

- (3)** Pull the bearing bracket 5 to the front together with pulling the border frame equally at both right and left to the front. In this state, fix screws 8 at two spots by using 4 mm wrench 7.

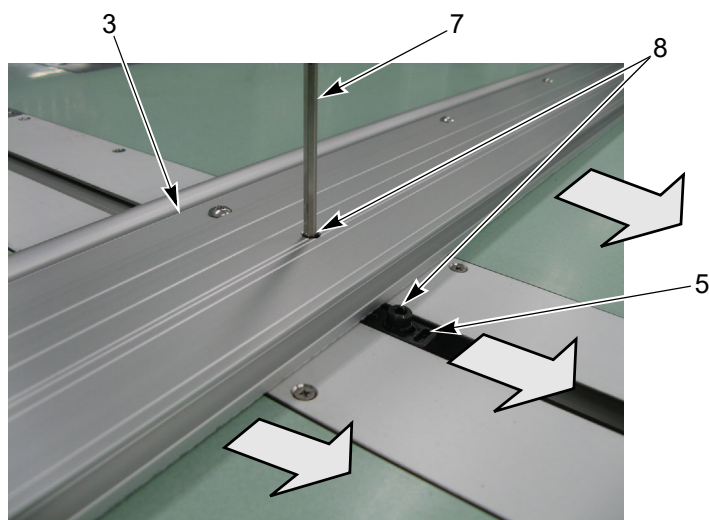

When pulling the bearing bracket 5 to your side, hook the groove 6 of the bearing bracket 5 by using the wrench, etc.

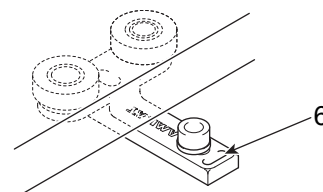

- (4)** Make a clearance 11 (2 mm) between the border frame 3 and XZsash 10.  
Fix the border frame 3 by attaching screws 12.

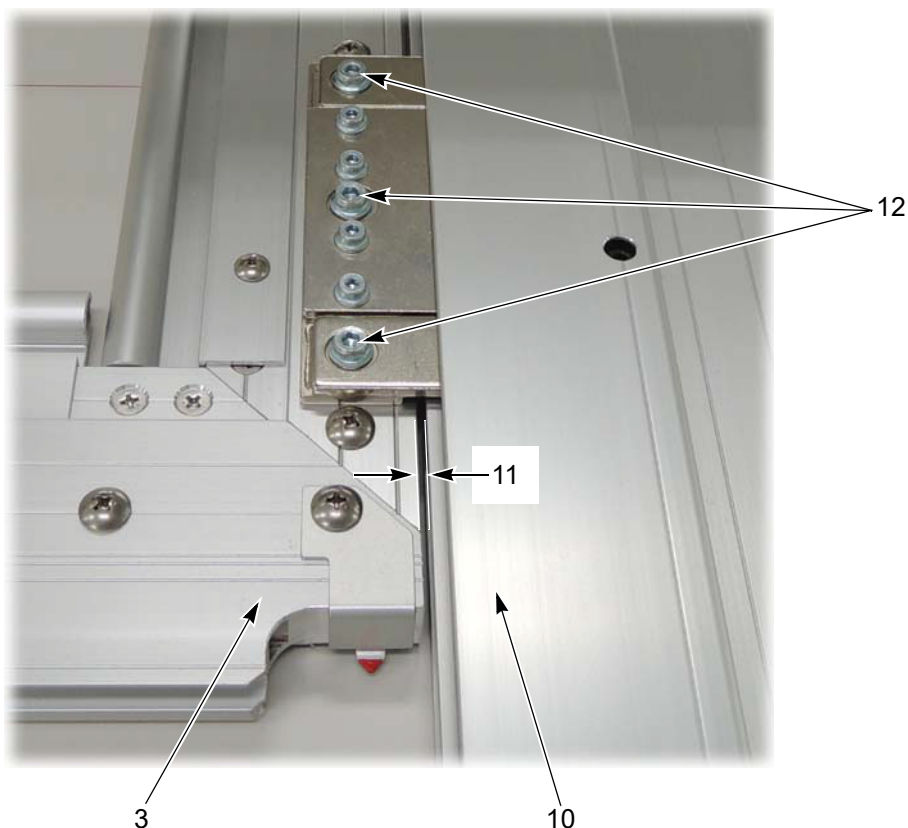

After the working, move the border frame 3 back and forth to check if there is no play at three bearings and the sash rail.

## 2-5. Thread course

Assemble the thread course according to the procedure shown in the figure below.

### AN EXAMPLE OF 12-NEEDLE MACHINE

Hexagon socket head cap screw M5\*10

Plain washer M5\*12

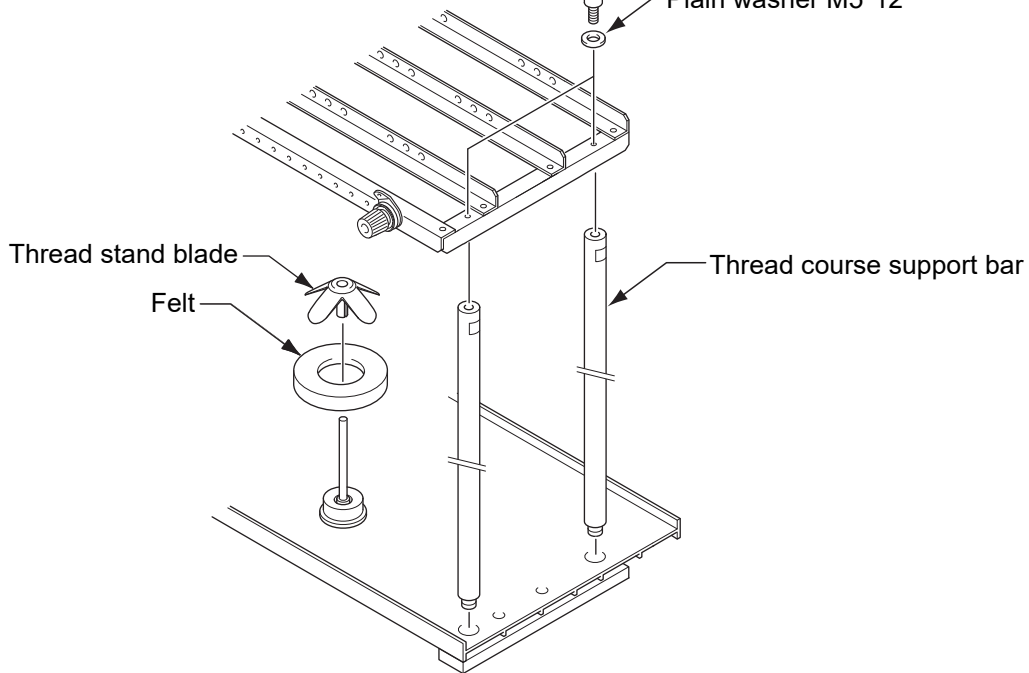

### AN EXAMPLE OF 15-NEEDLE MACHINE

Hexagon socket head cap screw M5\*10

Plain washer M5\*12

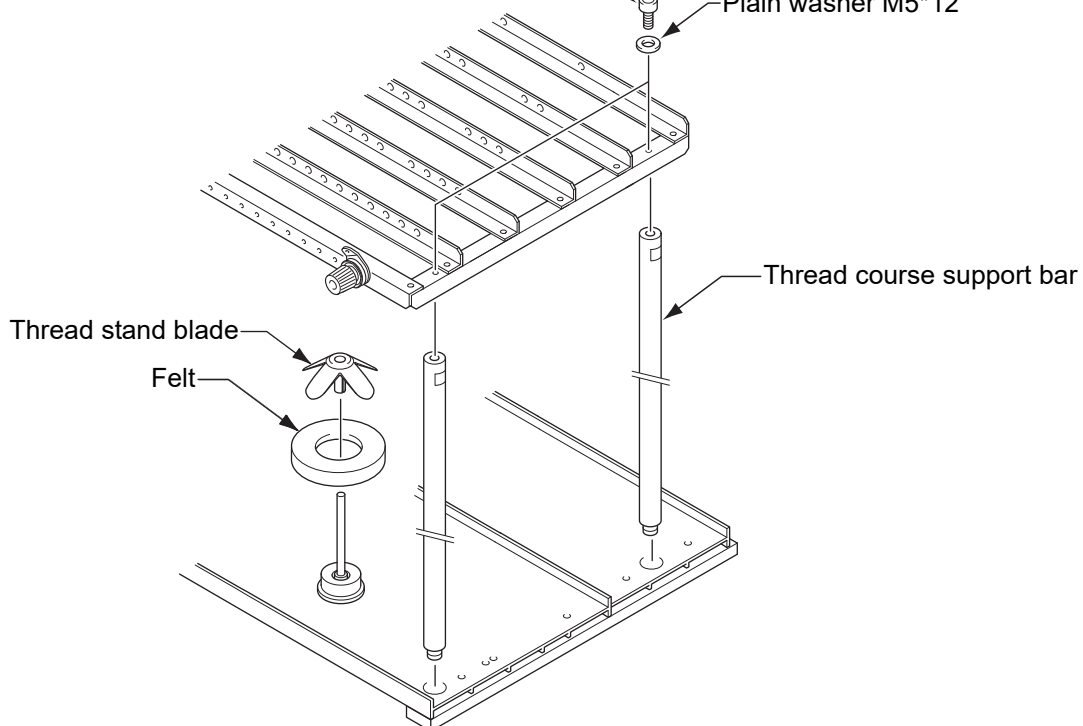

### 2-6. Operation panel

(1) Loosen the knobbed screw 1, and install the operation panel 2 on the pipe 3.

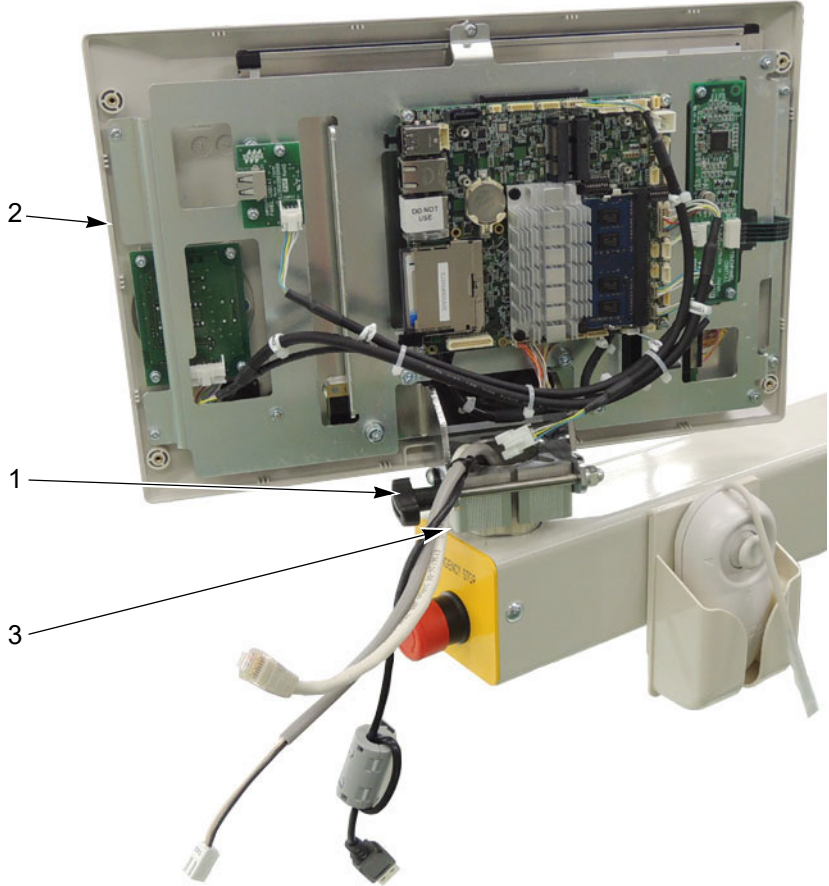

- (2)** Connect the operation panel communication harness 4, the operation panel power supply harness 5, and the LAN cable 3 m harness 6 to spots shown in the photo below. The operation panel communication relay harness 7 is not connected. So, leave it as it is.

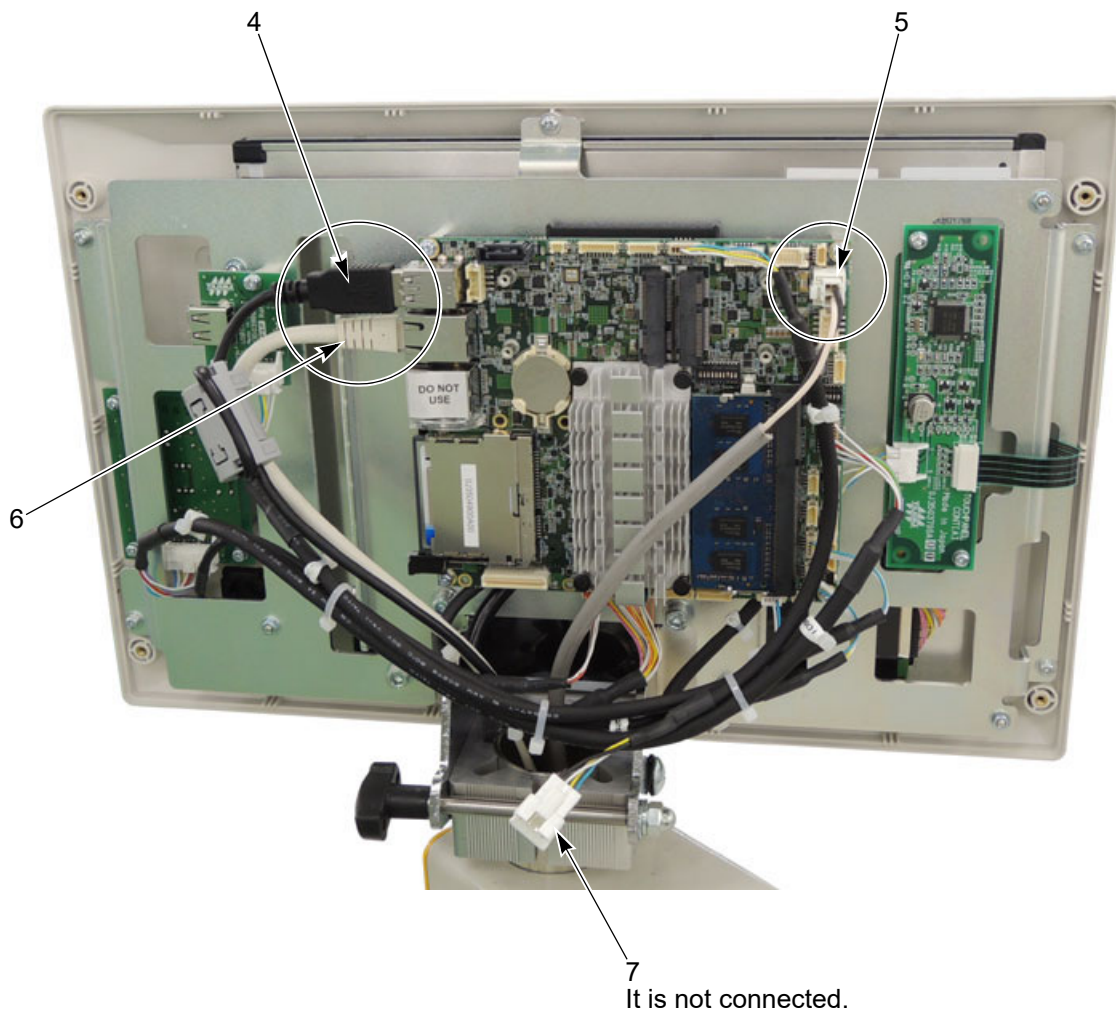

## 2-7. Beam sensor (limited model)

For the model with Y-emb. space 1500 mm and equipped with ESQ-C, align the two arrow labels 2 affixed onto the beam sensor 1 and the table to attach the beam sensor 1. Also attach the reflector to the opposite side.

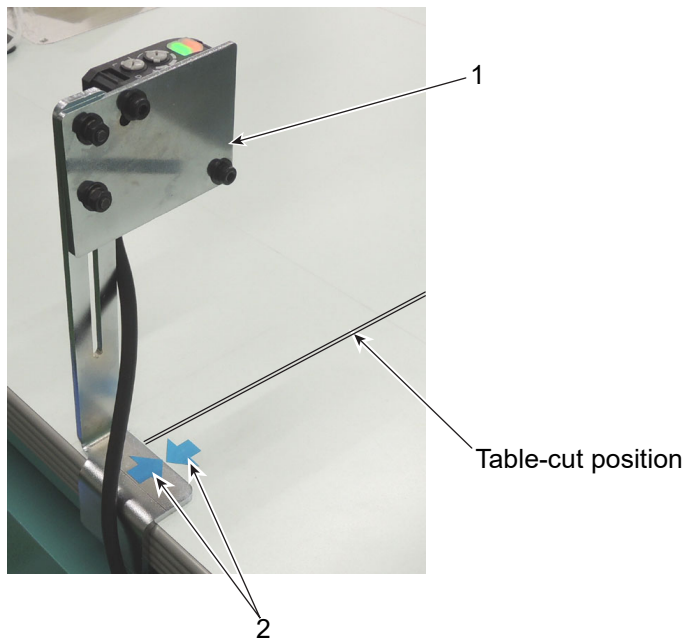



## Chapter 3 Connection of power cord

### 1. Important safety instructions



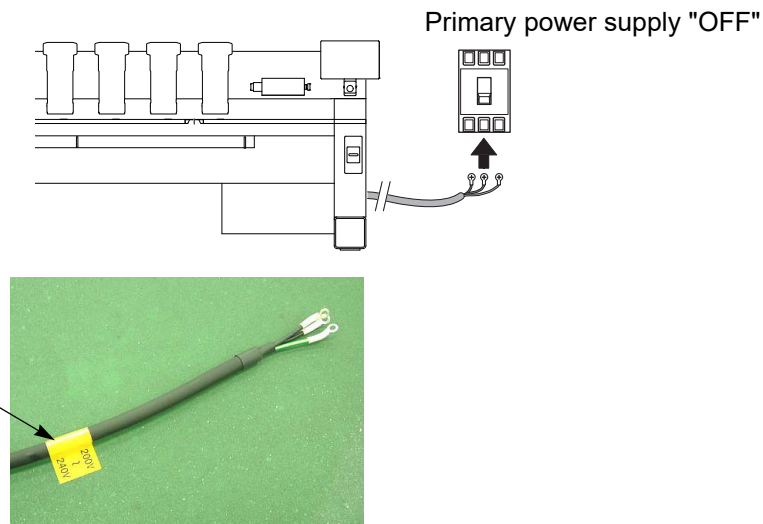

#### DANGER

-  When you connect the power cord, be sure to turn "OFF" the primary power supply. There could be a danger of electric shock, burning or death. In addition, check if the voltage of the voltage indicating label that is attached to the power cord fits to voltage spec. on your side, and then connect the power cord to the primary power supply.



-  If the machine needs to be connected to an external power supply, the power supply cable connection must be done only by the service personnel assigned and trained by TAJIMA or qualified technician.

#### WARNING

-  When supplying the power, conform to excess voltage category "III".
-  Connect the machine to the power supply line that is not connected to machines subject to large load fluctuation such as elevators and presses so that the machine can operate in stable conditions.
-  Check if power voltage is enough for operating the machine by using a multimeter.  
Voltage: Within  $\pm 10\%$  of the rated voltage
-  The power supply cable must be laid out of the operator's moving area so that the operator does not step on the cable.

## ⚠ WARNING

- ⚠ Insert the power cable plug fully. If a metallic part etc. touches a blade in the plug, it may cause fire and/or electric shock.
- ⚠ Since there is the danger of electric shock due to leak current, be sure to connect the grounding wire. In addition, degree of grounding should be type D or higher (grounding resistance 100 ohms or less).

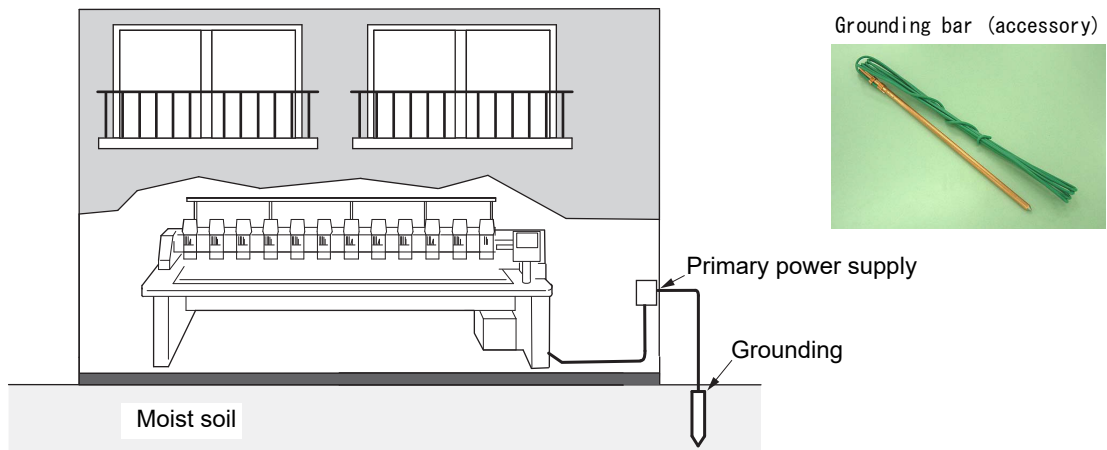

## ⚠ CAUTION

- ⚠ In addition to full-time leak current, leak electric current generated by harmonics and surge flows in the power cable of the machine. For this reason, if selection and installation of breaker of leak current and leak current relay used for the factory are not correct, malfunctioning of the machine may occur.  
Regarding connection of power cord, observe the following items.
- ⚠ Use a breaker of electric current leakage and leak current relay for which measures are taken against harmonics and surge. If such a breaker and a relay are not available, select conventional breaker and relay with sufficient leak current capacity to absorb leak current caused by harmonics and surge. (In this case, constant leak current must be controlled satisfactorily.)
- ⚠ Regarding capacity of electric current leakage for breaker of electric current leakage and leak current relay per machine, please consult your local TAJIMA distributor.
- ⚠ For actual product names of breaker of electric current leakage and leak current relay for which measures are taken against harmonics and surge, please consult your local TAJIMA distributor or electric engineers.
- ⚠ To prevent the machine from property damages, one embroidery machine should be connected to one no fuse breaker. Property damages include a drop of output of the main shaft motor, etc., stop position error and color change error caused by the stop position error, design displacement, etc.

## Chapter 4 Operation panel settings

### 1. Parameter setting

A parameter list is attached to the back of the operation panel. Check setting values. At this moment, check also version of the software.

"Parameter setting chart" at shipment from the factory is attached.



Setting of parameter is targeted for functional limit. For the detail, refer to the user's manual of the machine or consult the distributor.

Regarding information about the latest version of software and how to obtain the software, consult the distributor.

## 2. Absolute origin search



 When performing this operation, do not put your hands, etc. on the machine table. You could be injured by moving frame.

This function makes the machine memorize the absolute origin. Perform this operation under the following conditions.

- When setting up the machine
- When installing software
- When replacing the frame, the embroidery frame might be moved with the power turned OFF.

Absolute origin is an anchoring point that calculates the current frame position. If the calculation is wrong, the following troubles will occur.

- Frame coordinates are not displayed correctly.
- The frame does not return to the interrupted position even after performing power resume operation.

Execute absolute origin search by the following operation.

**(1) Icon F**

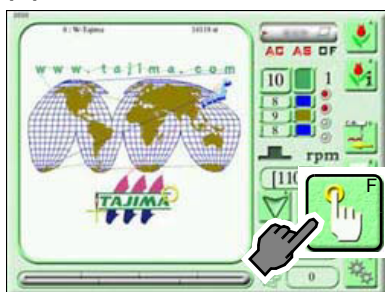

**(2) Icon O**

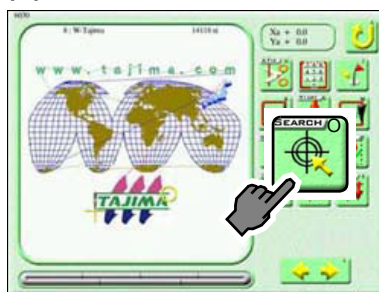

**(3) Yes (Completed)**



After Frame Travel, the frame will return to the previous position.

# Chapter 5 Level adjustment

## 1. How to use level gauge

Adjust level by using a level gauge in the state of no slant or contortion of the machine. There are four spots for measuring.

Level gauge



Use the level gauge of 60 cm length or longer and sensitivity within 0.5 mm/m.

Magnet holder



### (1) Level adjustment in right and left direction

Place the level gauge 1 on the square pipe.

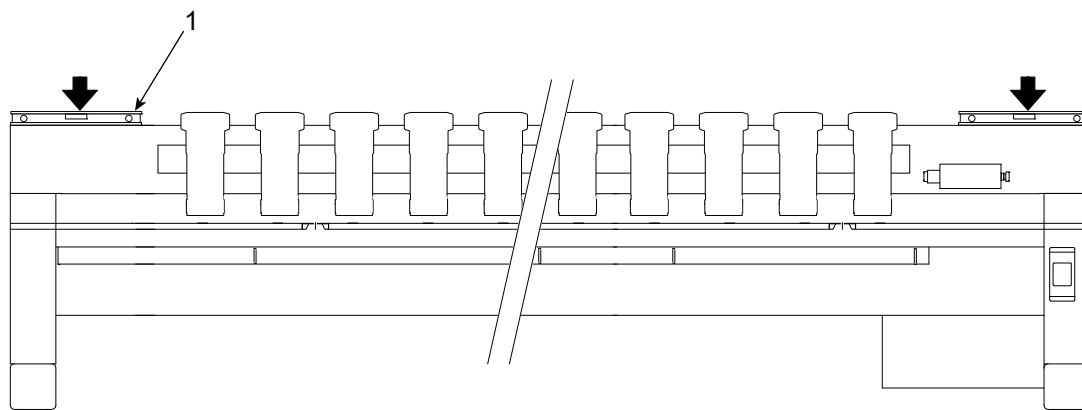

**(2)** Level adjustment in front and rear direction

Attach the magnet holder 2 so that the corner of the magnet holder 2 comes to the center of the punching mark 3. Place the level gauge 1 on the magnet holder 2.

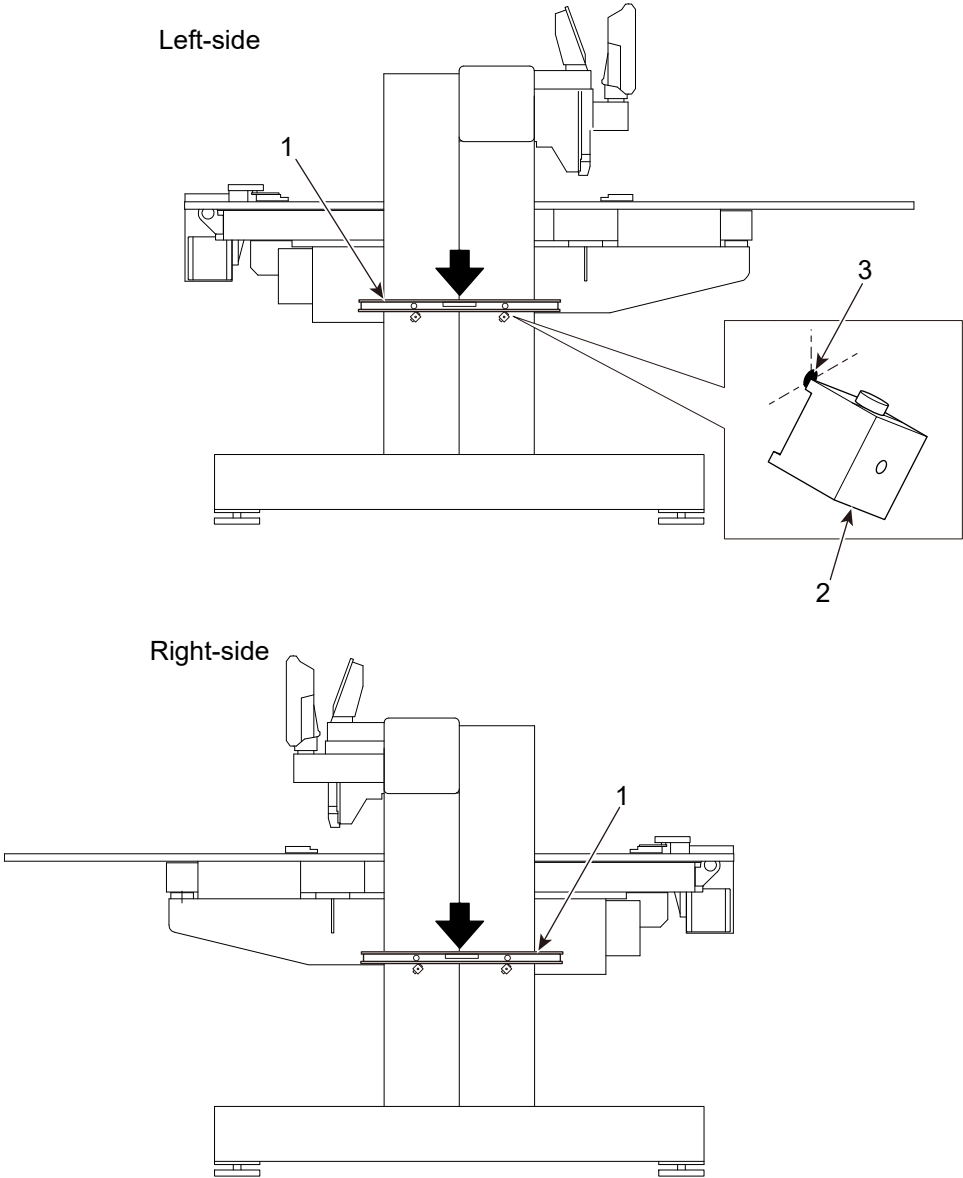

## 2. Level adjustment

Adjust two pieces of leveling bolt 2 on a diagonal line while checking bubble 1 of the level gauge, tighten the nut 4 after adjusting the remaining two pieces of leveling bolt 3. At this time, perform tightening so that equal load is applied to four pieces of hexagon bolt.

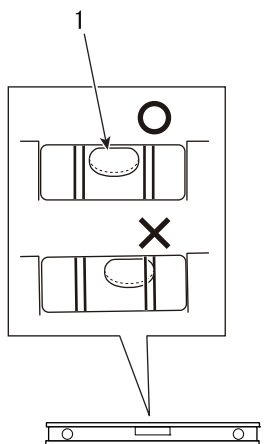

If a bubble stays within the range (inner lines) of a level gauge with its sensitivity of 0.5 mm/m, the degree of level becomes “±0.5°”.

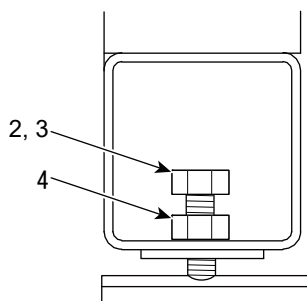
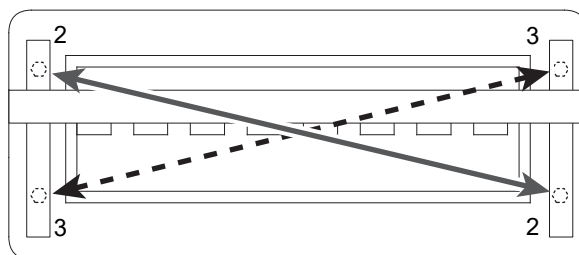
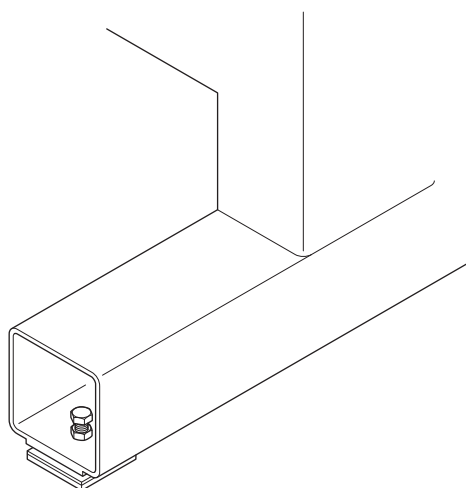

### 3. Center support

This work is supported only for the machine model in which the center support is packed.

The center support and the vibration-preventive base or the support base are packed in G-spec. or larger machine. The center support sometimes may not be packed in some G-spec. or larger machine depending on the specification.

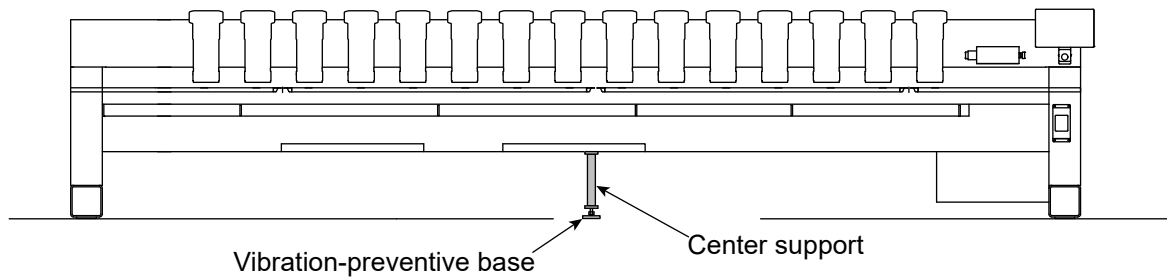

Install the center support at the center of the machine.

Center supports (A to C) packed with the machine differ in length depending on machine model. Fix the center support (B or C) to the machine by using the accessory hexagon socket head cap screw.

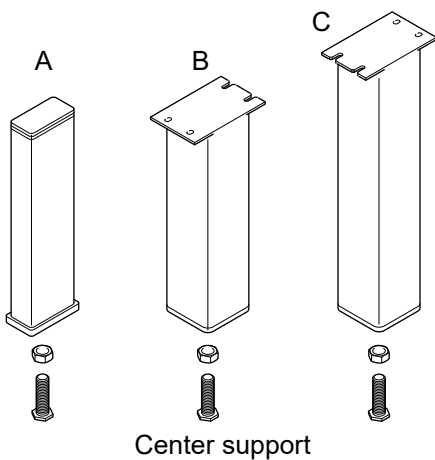

The support base is required when the anti-vibration stand is attached.

The following is a standard example of attaching the center support. In case of installing the anti-vibration stand additionally, the support base is packed in the machine instead of the vibration-preventive base.

**(1) G-spec. machine**

Frame drive type	Total machine length
Standard drive	5,786 to 6,395 mm
Cross Z-drive	5,876 to 6,485 mm

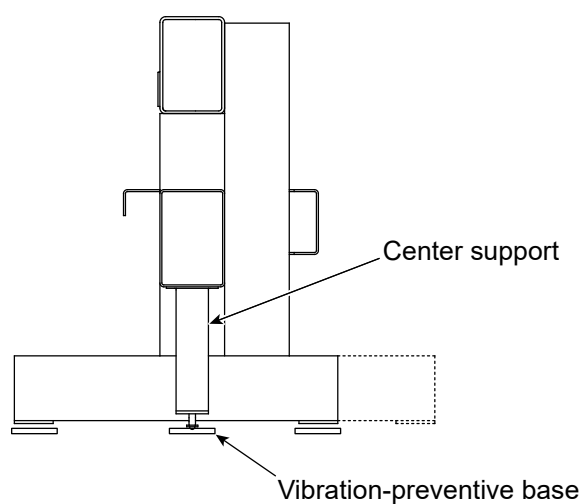

**(2) 7 meter machine**

Frame drive type	Total machine length
Standard drive	6,396 to 7,000 mm
Cross Z-drive	6,486 to 7,090 mm

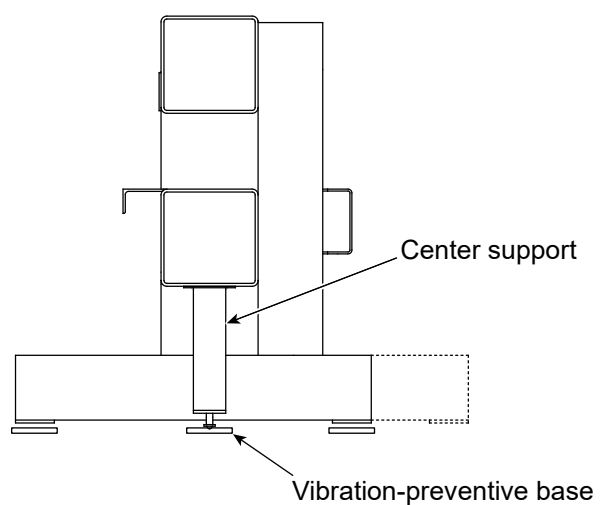

**(3)** 8 meter machine

Frame drive type	Total machine length
Standard drive	7,001 to 8,295 mm
Cross Z-drive	7,091 to 8,385 mm

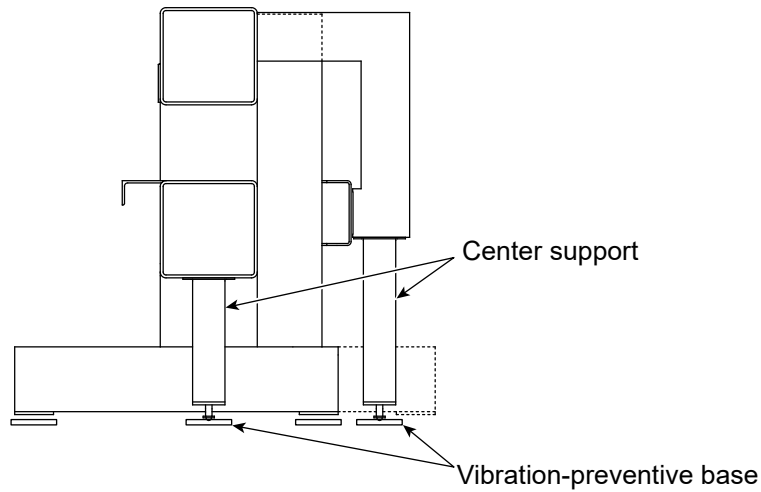

**(4)** 8.5 meter machine

Frame drive type	Total machine length
Standard drive	8,296 to 8,895 mm
Cross Z-drive	8,386 to 8,985 mm

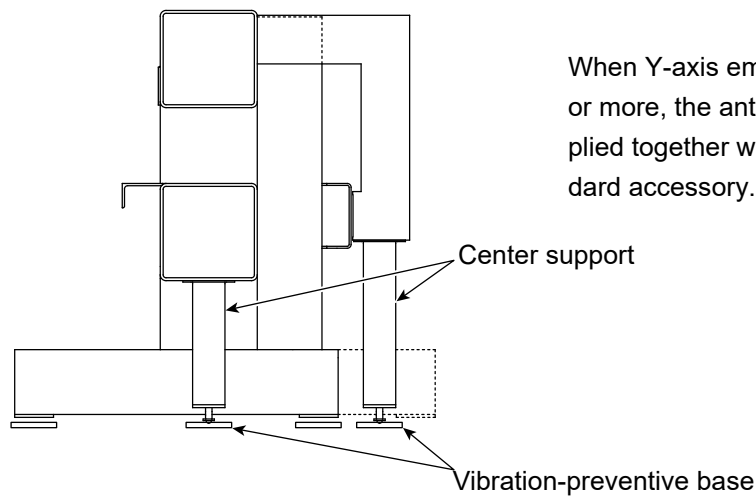

When Y-axis embroidery space is 1,200 mm or more, the anti-vibration stand is also supplied together with the machine as the standard accessory.

**(5)** 9 meter machine

Frame drive type	Total machine length
Standard drive	8,896 to 9,530 mm
Cross Z-drive	8,986 to 9,620 mm

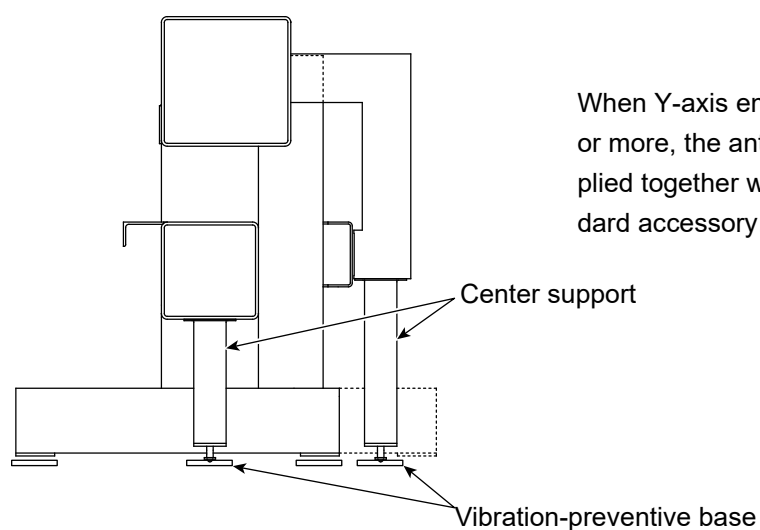

When Y-axis embroidery space is 1,200 mm or more, the anti-vibration stand is also supplied together with the machine as the standard accessory.

**(6)** 10 meter machine

Frame drive type	Total machine length
Standard drive	9,531 to 10,910 mm
Cross Z-drive	9,621 to 11,000 mm

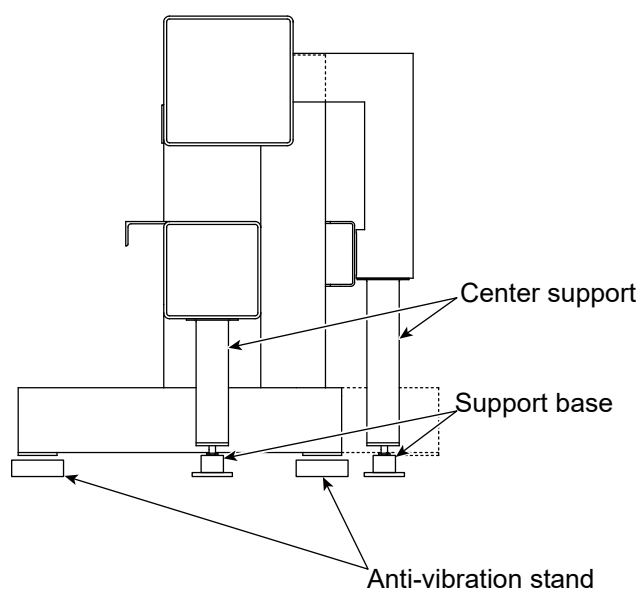



## Chapter 6 Adjustments

### 1. Needle locating position

This working checks the first needle and the last needle of all heads.

To lower the needle bar, follow the procedure below.

- (1) Press the main shaft angle display icon (  ) longer. It will be displayed in blinking (  ) and "Main Shaft Brake" will be changed to "No".

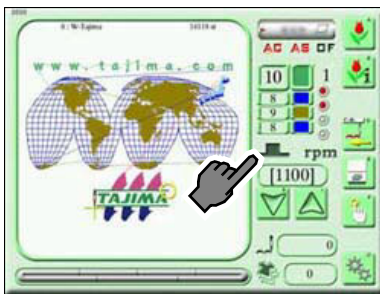

Each time pressing it longer switches between ON and OFF.

Starting the machine or turning OFF/ON the power switches "Main shaft brake" to "Yes".

- (2) Insert the main shaft handle 2 into the left-side box, and turn the main shaft handle 2 counterclockwise to set the main shaft angle to 178°(needle bar lower dead point).

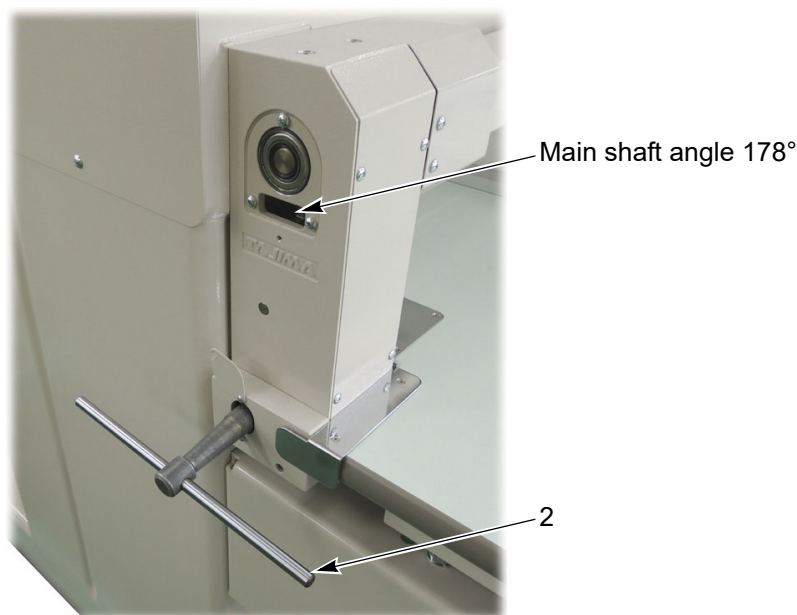

- (3) Lower the needle bar by hand.
- (4) Check if the needle 3 is located in almost the center of the needle hole 4.

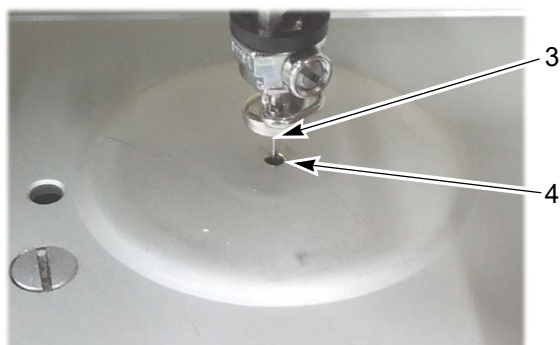

Adjust right and left positions of needle bar case. If the needle locating position is misaligned between the first needle and the last needle, allocate the misalignment so that the needle location comes to the center as much as possible.

- (5) Check the needle locating position of the last needle in the same procedure by sliding the needle bar case.
- (6) To adjust needle position of a certain head, adjust its needle bar case.  
To adjust a certain head, loosen the screw 5 (right and left two spots) to slide the needle bar case right and left.



- (7) When all heads are misaligned by about the same degree, perform adjustment on the screen of parameter setting [P8] → [85. Machine Adjustment] → Perform adjustment on the screen of [7. Display of Needle Pos. Angle]. (Refer to the user's manual of machine)

Refer to the value 6 described on the label.



## 2. Lower dead point

This working checks from the 1st needle to the last needle (all needle bars) of all heads. For the 1st needle, use the accessory lower dead point gauge to check the lower dead point. For the 2nd and later needle, use the needle bar connecting stud gauge to check it.

Lower dead point gauge (accessory)



Engraved mark B

For TMCP-VF, use the lower dead point gauge which has the engraved mark B. The lower dead point gauge which does not have the engraved mark B cannot be used, because it is for other models.

- (1) Insert the main shaft handle 1 into the left-side box, and turn the main shaft handle 1 counterclockwise to set the main shaft angle to 178°(needle bar lower dead point).

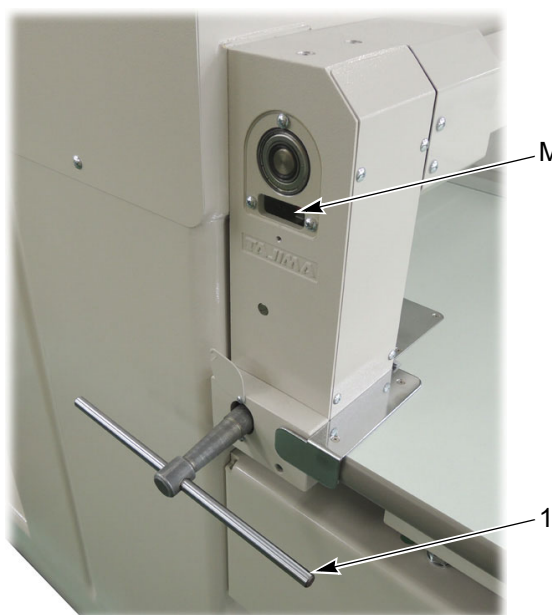

Main shaft angle 178°

1

**(2)** Lower the needle bar 2 by hand, and loosen the screw 3.

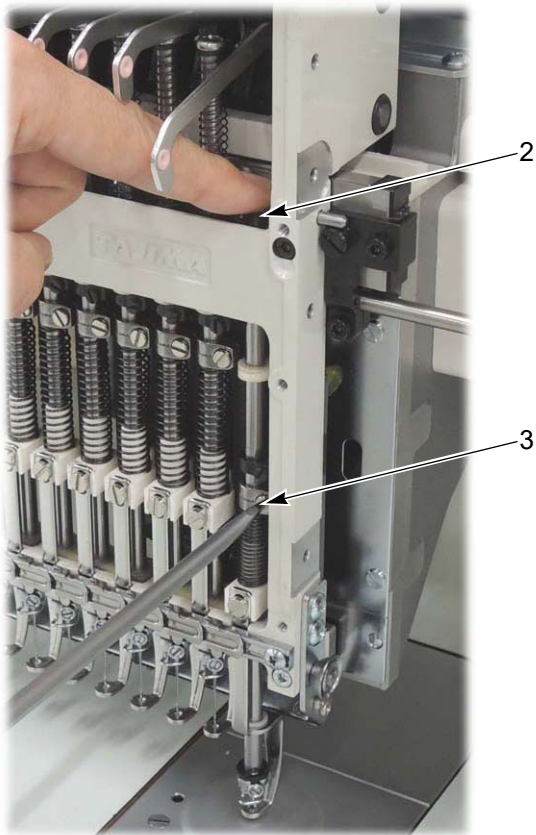

**(3)** Install the lower dead point gauge 5 so that the needle comes into the groove 4.

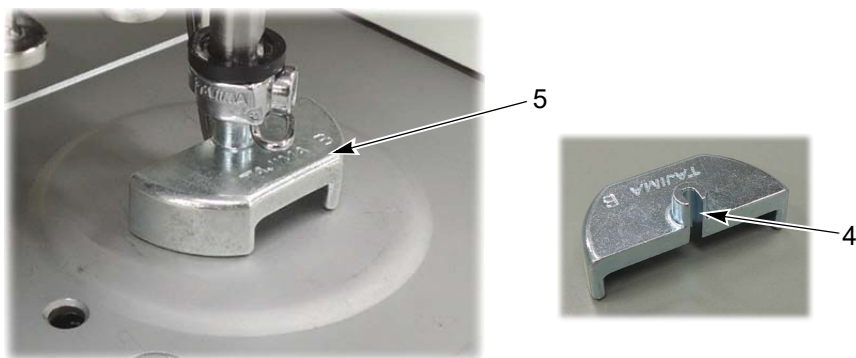

- (4)** Make no space (section A) between the needle bar 2 and the lower dead point gauge 5, orient the set screw 6 of the needle clamp slightly rightward, and tighten the screw 7.

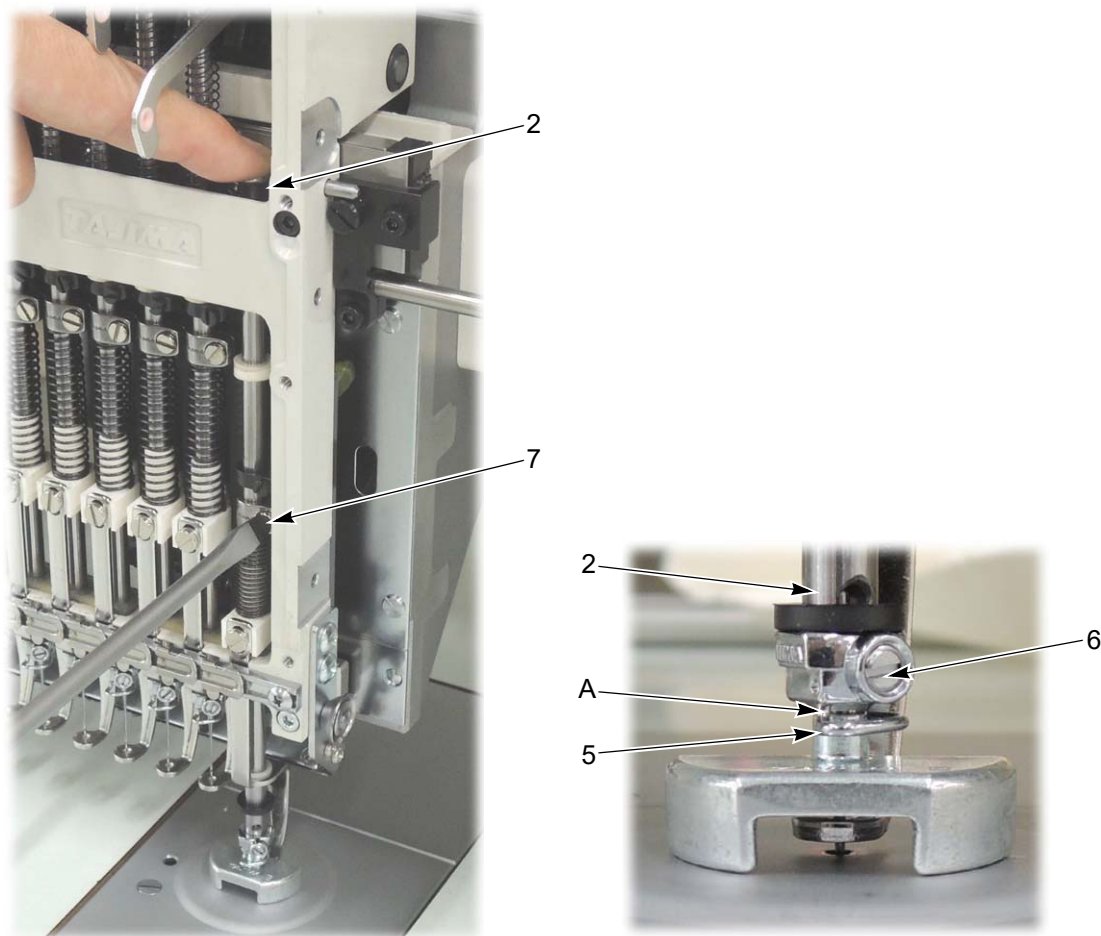

- (5)** Detach the lower dead point gauge, and set the main shaft angle to 100° (Stop position).  
**(6)** Perform Color Change to the next needle bar.

- (7) Attach the connecting stud gauge 8 to the needle bar for the first needle. Loosen the wing screw 9, tighten the wing screw 9 with no gap between section A and B, and remove the connecting stud gauge 8.

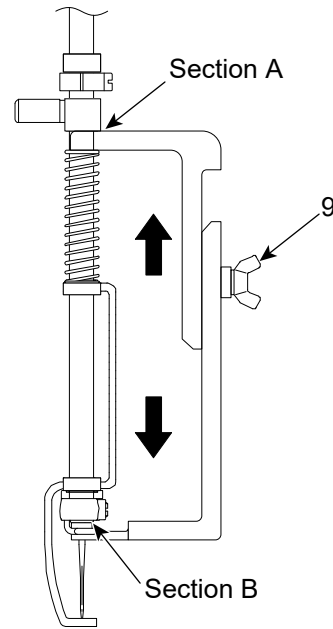
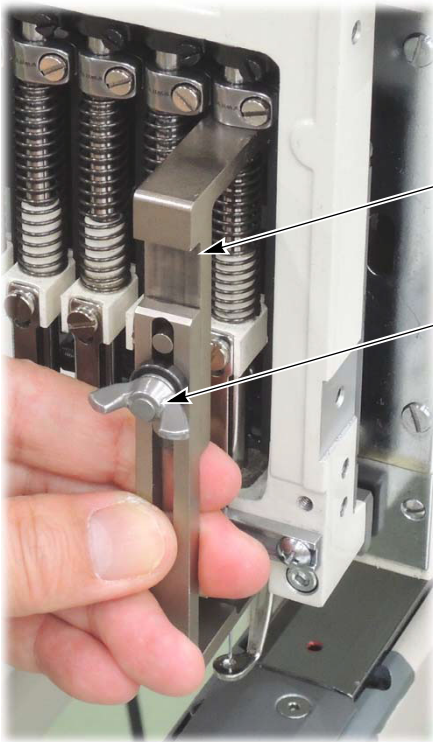

- (8) Attach the connecting stud gauge 8 to the 2nd needle. Loosen the screw 10, and tighten the screw 10 with no gap between section A and B.

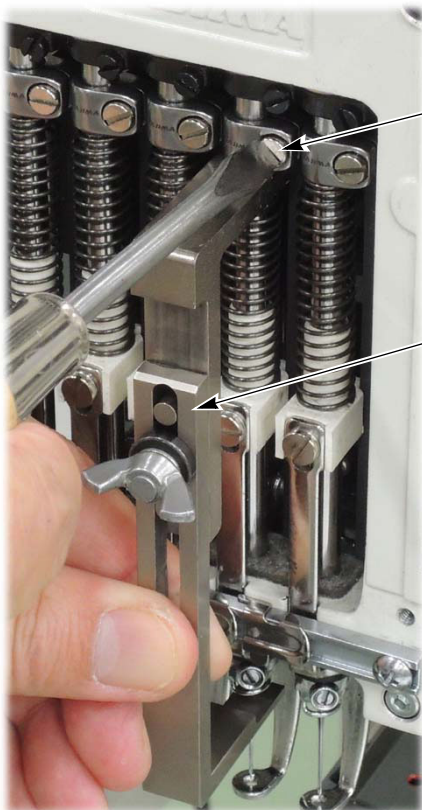

Perform working of the 2nd needle and after to the last needle.

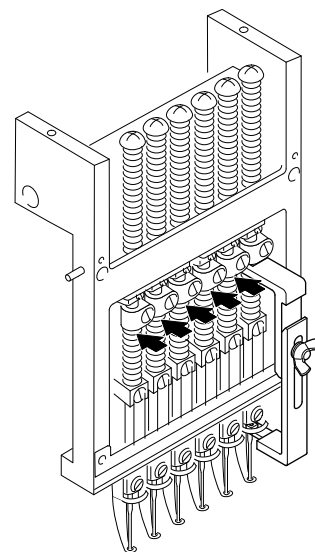

### 3. Upper dead point

Select "Needle bar upper dead point adjustment" by the following operation.

(1) Icon G

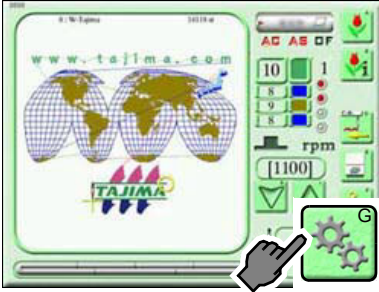

After that, cancel the functional limit level. For details, refer to the chapter for "Parameter" in the user's manual.

(2) ALL Yes

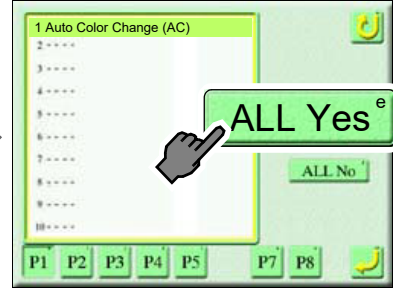

(3) To set

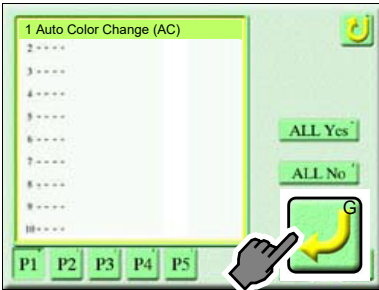

(4) To set

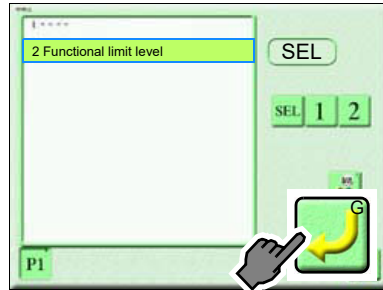

(5) Icon A

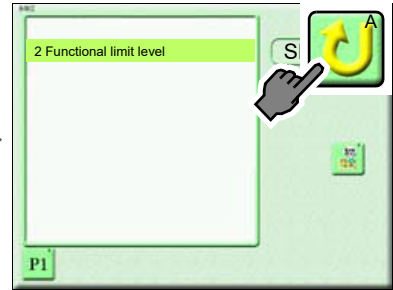

(6) 85 Machine adjustment

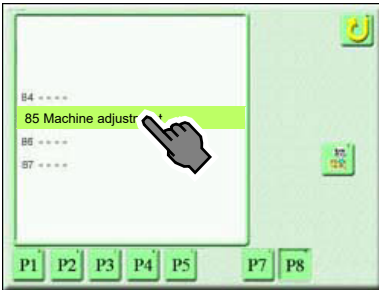

(7) Icon T

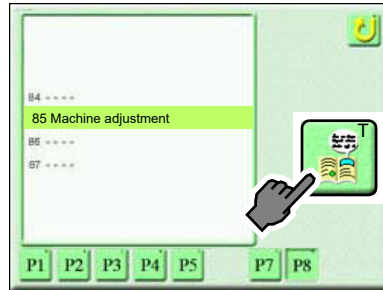

(8) P2

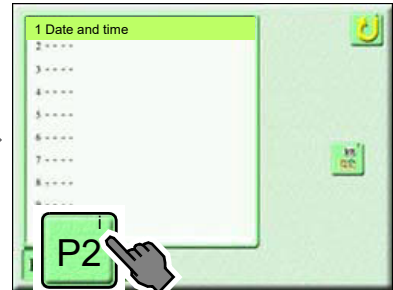

(9) 20 Needle bar upper dead point adjustment



(10) Icon T

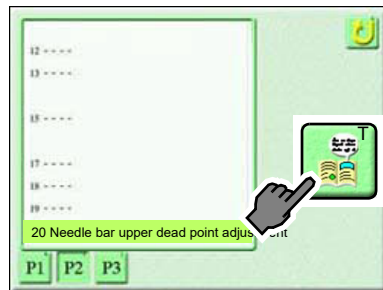

- (11)** Start the machine. The machine will perform the following operations (a to c).
- For the second and subsequent operations, the presser foot will move down.
  - The needle bar case will move to the next needle bar.
  - The main shaft will rotate and the main shaft angle will become  $7^\circ$ .

Although the upper dead point of this machine is  $0^\circ$ , the upper dead point stopper 1 is fixed at the position where the upper dead point stopper 1 touches the cushion ring 2 at main shaft angle  $7^\circ$  in production at the factory.

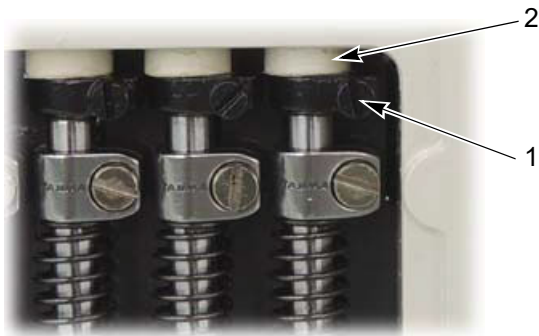

- (12)** Loosen the screw 3 of the upper dead point stopper 1. Tighten the screw 3 with the upper dead point stopper 1 in light contact with the cushion ring 2.

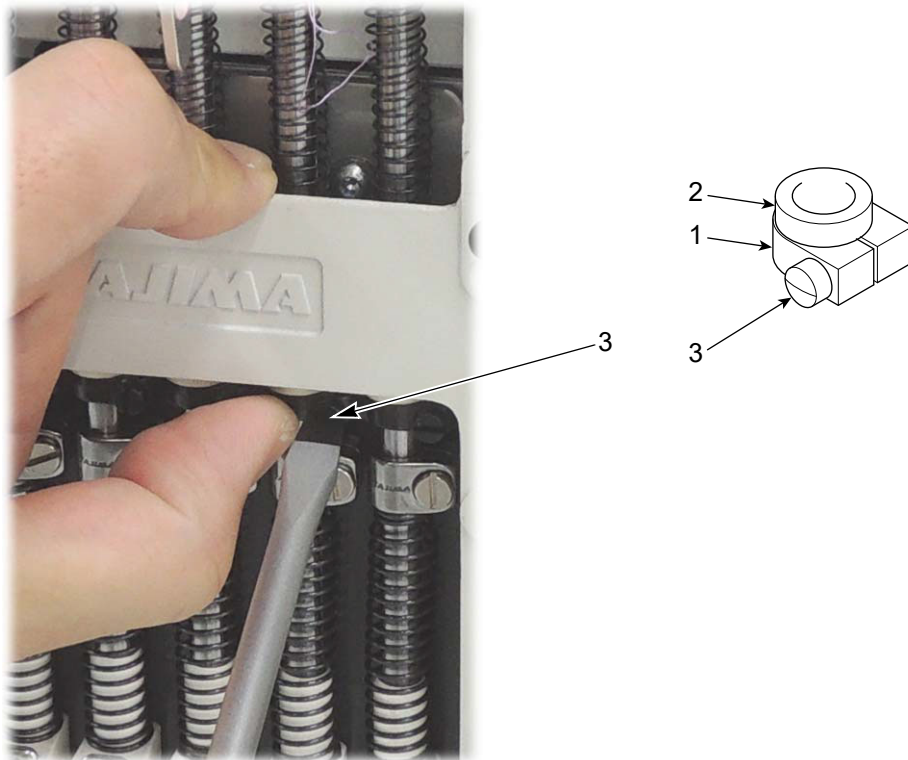

**(13)** When you start the machine, the operation "a to c" described above will be performed after moving to the next needle bar. Adjust the upper dead point in the same way.

**(14)** After the working, press icon A. The main shaft will return to the fixed position (100°).

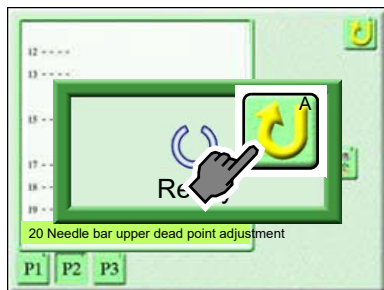

#### 4. Bevel gear

Check play of the bevel gear 1 and the bevel gear 2 at all heads. It is normal if the bevel gear 2 moves slightly (0.1 to 0.2 mm).

If there is no "Play", loosen the set screw 3 of the bevel gear 1 to adjust the position of the bevel gear 1.

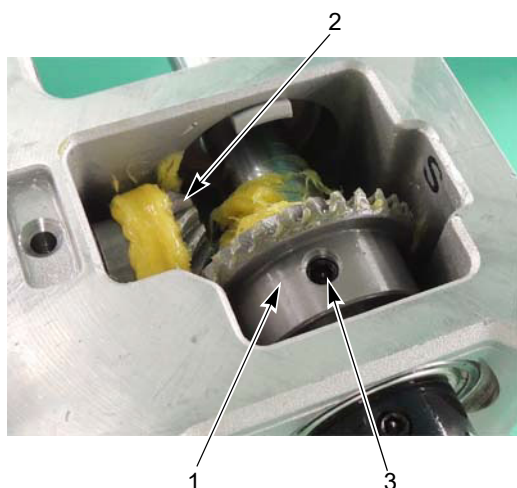

## 5. Needle and rotary hook

This working checks the first needle and the last needle of all heads.

- (1) Turn the main shaft clockwise to set to the position where the tip 1 of the needle meets the hook point 2 of the rotary hook (198° to 204°) while lowering the needle bar.
- (2) Check if the gap (A) between the scarf 3 of needle and the hook point 2 of rotary hook is 0.1 to 0.3 mm.

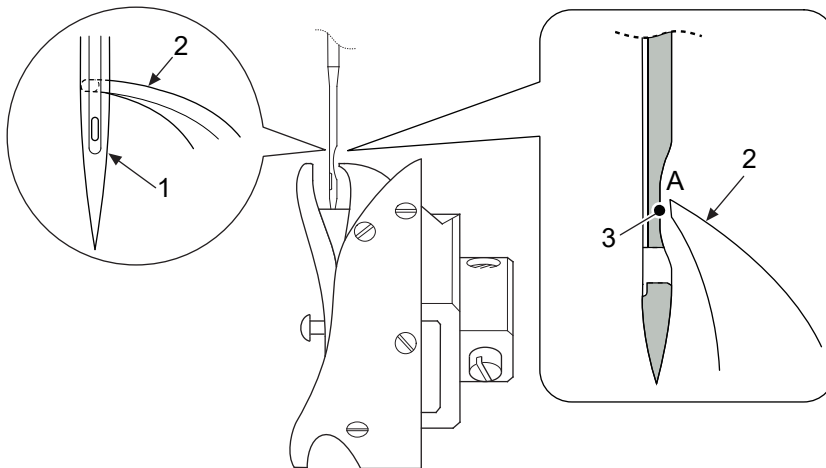

Push the needle lightly using a flat head driver.



## Chapter 7 Idling and test sewing

### 1. Lubrication

#### ! CAUTION

- ! When performing lubrication, use only Tajima's genuine TF oil (packed with the machine). If you use other oil than this by necessity, select oil equivalent to ISO viscosity grade: VG20.
- ! After the working, attach all covers that were detached.

#### 1-1. Rotary hook

To lubricate, use the oiler (accessory). Lubricating spots are raceway 1 and lubrication hole 2.

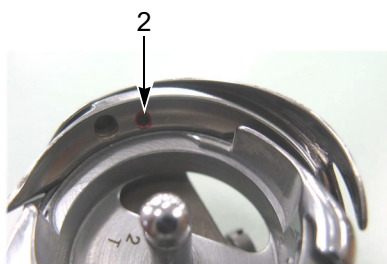
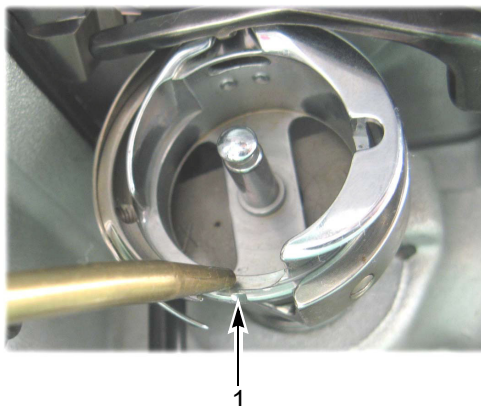
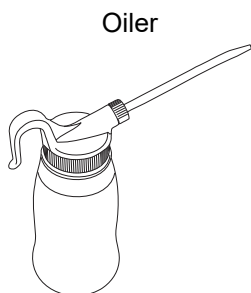

To lubricate lubrication hole, attach the nozzle 3 (accessory) to the tip of the oiler.

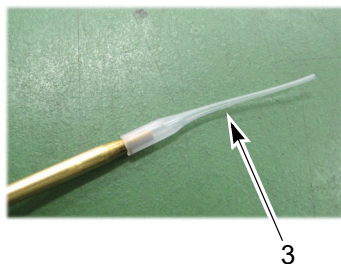

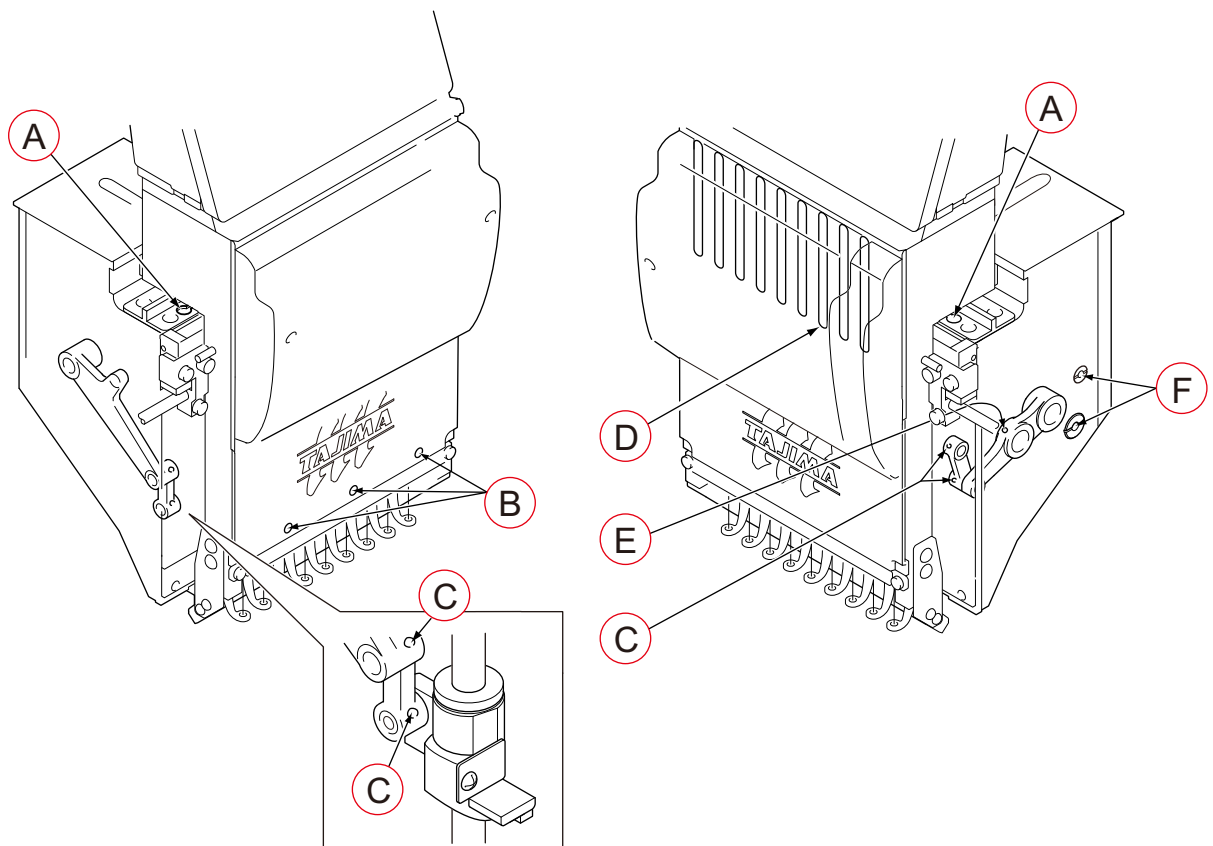

## 1-2. Inside of arm



	Lubricating spot
A	Needle bar drive shaft (Either one spot)
B	Needle bar (spot indicated by red mark)
C	Lubrication hole of connecting part
D	Needle bar (all needles)
E	Lubrication hole of needle bar lever
F	Wick of stepped pin

## 2. Idling, jump

### CAUTION

-  When operating the machine, check if there is no person around moving section and all covers are attached to prevent accident resulting in injury or death.
-  Keep on idling until antirust applied on rotary hook is completely removed. If antirust remains, it could cause thread breakage.

- (1) Set "Upper thread breakage detection" and "Under thread breakage detection" to "not to detect" in parameter setting.
- (2) Execute the data set of the design data containing jump codes.
- (3) Start the machine to perform idling. At the beginning, start the machine with about 250 rpm or so and increase the speed up to 650 rpm while checking running condition of the machine. Spare time for 20 to 30 minutes for operation. Check if no misjumping occurs using design data that includes jump codes.  
When misjumping occurs, it is necessary to adjust the position of the upper dead point stopper. (→ p.41)
- (4) After the working, check if no heat occurs from the side part of the arm, the needle bar drive shaft, etc.

### 3. Threader

If the thread does not pass to each section correctly, it could cause trouble such as the deterioration of embroidery or the thread breakage, etc. Pass the thread correctly referring to the figure below.

- (1) Place the thread cone 1 on the thread stand blade 2.
- (2) Thread through the thread course 3.

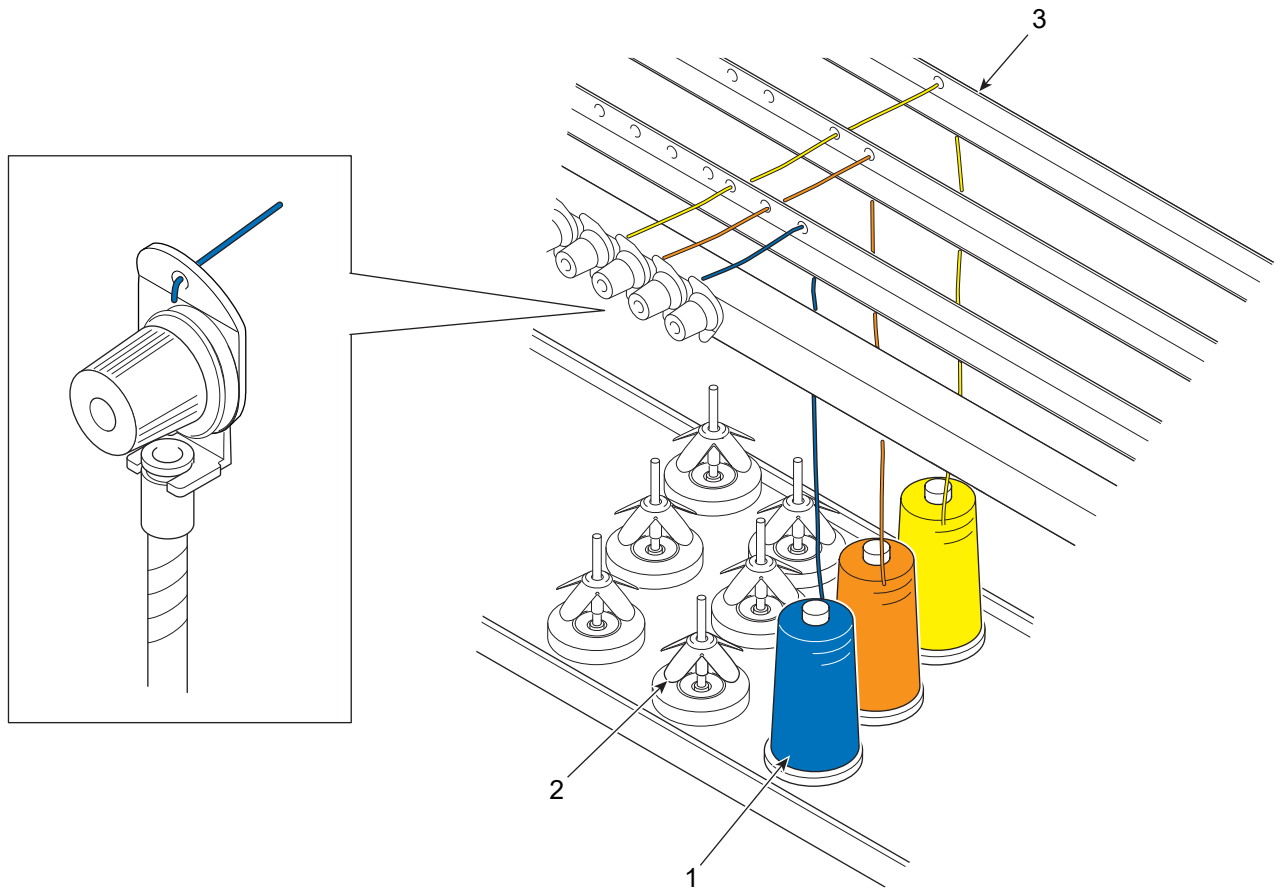

**(3)** Put the thread into the groove 4 of the tension stud. (Indicated by an arrow)

**(4)** To perform threading through the spiral tube 5, use the threader 6 (accessory).

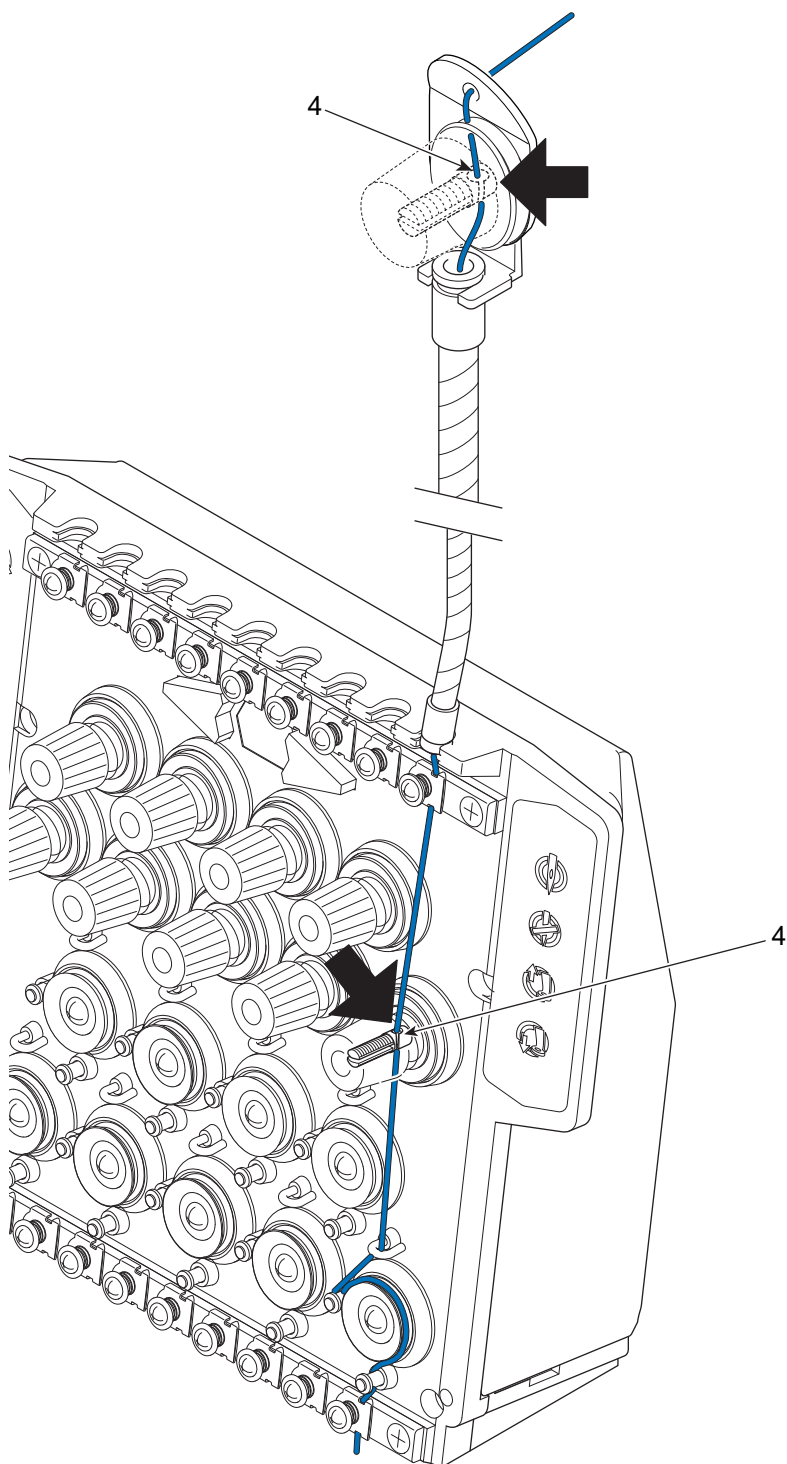

Threading through spiral tube 5

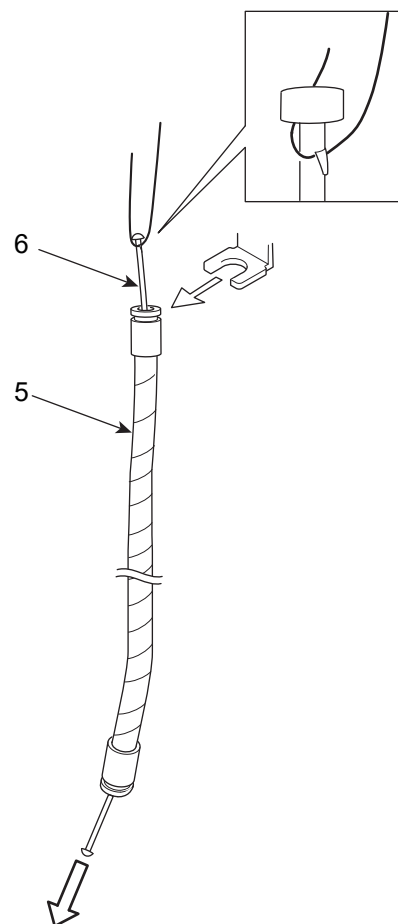

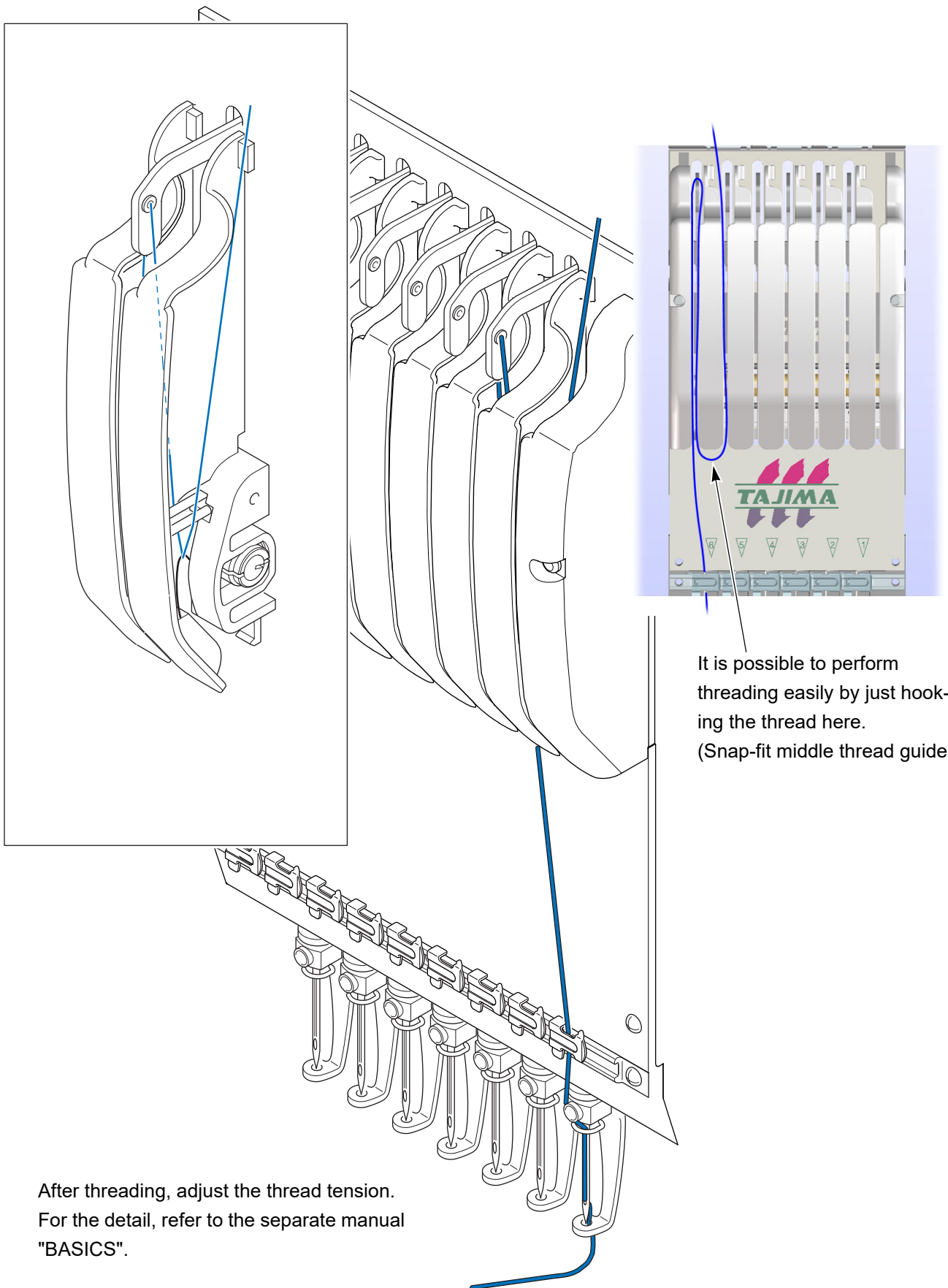

After threading, adjust the thread tension.  
For the detail, refer to the separate manual  
"BASICS".

## 4. Test sewing

### CAUTION

-  For long life machine operation, operate the machine with about 70% of the maximum speed as "Operation for total fitting" for about two weeks after installation. By performing operation for total fitting, life of the machine will become longer, which will be useful to avoid unexpected troubles.

- (1) Check each movement such as color change, manual ATH, etc.
- (2) Adjust the tension of the upper thread and the under thread, and perform test sewing. For adjusting method, refer to the separate volume "BASICS".

1st Edition

May, 2018

4th Edition

April, 2022

■ **Manufactured by : TISM Co.,Ltd.**

Address : NO.1800, Ushiyama-cho, Kasugai, Aichi-pref., 486-0901, Japan

TEL : 81-568-33-1161    FAX : 81-568-33-1191

■ **Distributed by : Tajima Industries Ltd.**

Address : NO.1800, Ushiyama-cho, Kasugai, Aichi-pref., 486-0901, Japan

TEL : 81-568-37-1130    FAX : 81-568-37-1230

●**Copy, reprint, or reform of a part or whole of this manual without permission is prohibited.**