

MACHINE SETUP INSTRUCTIONS

***TFMX* SERIES**

[IMPORTANT]

**To handle the machine correctly and safely,
perform operations according to the procedure
described in this manual.**



User's Manual / Parts List

User's manual / Parts list are stored as the PDF file in the accessory DVD. Please read the contents thoroughly and then use the machine or the optional device.

To see the PDF file, "Adobe Acrobat Reader" is necessary.

User's manual, parts list of the optional devices you have not purchased are included in this DVD. Please note beforehand.

[How to open the DVD]

1. Insert a DVD into the personal computer.



Since the following pop-up window will be displayed automatically, select "Open folder to view files" (indicated by the arrow).



2. Double-click left "titlepage".

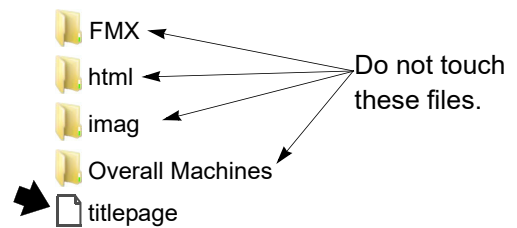

3. Select displaying language.



4. Select "User's Manual" or "Parts List", and then select the title you desire.



The figure above is an example selecting "English (Multiple Languages)" in the above 3.

Foreword

This manual introduces the procedure for setup of TAJIMA embroidery machine TFMX series.
Please understand the contents, and then use the machine.

The contents of this manual may contain discrepancies in detailed information when compared with the actual product.

If any question about the products or contents of this manual arises, please consult your TAJIMA distributor.

Regarding optional device, refer to the user's manual (separate volume) of the device.

Please keep this manual with care near the machine for quick reference.

TISM Co.,Ltd.

SAFETY PRECAUTIONS

To prevent any harm or damage to the person who use this product or other person, we describe items that must be surely followed as below.



Indicates that there is a lot of danger of death or serious injuries [*1] if handled by mistake.



Indicates that there is a likelihood of death or serious injuries [*1] if handled by mistake.





Indicates a potentially hazardous situation which may result in minor or moderate injury [*2] or property damage if handled by mistake.

*1: A condition caused by electric shock, injury, fracture of a bone, etc., that leads to aftereffects, or an injury that necessitates hospitalization or visits to a hospital over a long period.

*2: An injury that does not necessitate hospitalization or visit to a hospital over a long period.

: Prohibited items

: Items that may cause electric shock if not observed

: Items that must be followed carefully to ensure safe operation



MUST DO LIST AT MACHINE INSTALLATION

MODEL:	M/NO.:
	DATE / / / PIC:

Check the following items in order after “Chapter 6 Level adjustment”.

Chapter 7 Adjustments	Remarks	✓
1. Needle locating position	Check and adjust the needle locating position. <ul style="list-style-type: none"> The 1st needle on all heads The last needle on all heads Equalize it at the 1st needle and the last needle.	✓
2. Lower dead point	Check and adjust the lower dead point.	✓
3. Upper dead point	Check and adjust the upper dead point.	✓
4. Bevel gear	Check and adjust bevel gears gap in front/rear, left/right direction.	✓
5. Needle and rotary hook	Check and adjust the needle and the rotary hook timing and the gap.	✓

Chapter 8 Idling and test sewing	Remarks	✓
1. Lubrication	Lubricate to the rotary hook and the inside of the arm.	✓
2. Idling, jump	Run the machine at least 20 minutes without threads for all needles to remove anti-rust liquid from the rotary hook.	✓
	Check if the reciprocator catches the needle bar stud at inching.	✓
	Check if the jump device operates properly.	✓
3. Threader	Pass thread correctly.	✓
4. Test sewing	Check if the thread breakage or the needle breakage occurs.	✓

Chapter 1 Transportation, storage, delivery

1.	Transportation, storage.....	1
2.	Installation environment.....	1
3.	How to carry.....	3
3-1.	When using a crane.....	3
3-2.	When using a forklift.....	4

Chapter 2 Installation

1.	Leveling bolt.....	6
1-1.	In case of stand shape A.....	6
1-2.	In case of stand shape B (with spacer).....	7
1-3.	In case of stand shape B (without spacer).....	8
1-4.	In case of stand shape C.....	9

Chapter 3 Detaching, attaching

1.	Detaching.....	10
1-1.	Stopper.....	10
2.	Attaching.....	11
2-1.	Thread course.....	11
2-2.	Operation panel (OP).....	12
2-3.	Beam sensor (limited model).....	13
2-4.	Lower unit of Sequin device III (Option).....	14

Chapter 4 Connection of power cord

1.	Important safety instructions.....	15
2.	Power cord.....	17

Chapter 5 Operation panel (OP) settings

1.	Parameter setting.....	19
2.	Frame Origin Memory.....	19
2-1.	TFMX-IIC, TFMX-II.....	20
2-2.	TFMX (L).....	21

Chapter 6 Level adjustment

- 1.** Level adjustment 22
- 2.** Attaching of center support (limited model) 24

Chapter 7 Adjustments

- 1.** Needle locating position 25
- 2.** Lower dead point 27
- 3.** Upper dead point 30
- 4.** Bevel gear 31
- 5.** Needle and rotary hook 32



Chapter 8 Idling and test sewing

- 1.** Lubrication 33
 - 1-1.** Rotary hook 33
 - 1-2.** Inside of arm and cylinder bed 34
- 2.** Idling, jump 35
- 3.** Threader 36
- 4.** Test sewing 39

Chapter 1 Transportation, storage, delivery

1. Transportation, storage

CAUTION



-  To prevent personal injury, lift or transport the machine in a safe manner to prevent it from tipping over or falling, based on the weight of the machine.
-  To prevent machine failure and premature deterioration, store the machine in the following environment.
 Humidity: 30 to 95%RH (relative humidity) without condensation
 Ambient temperature: -10 to 60 °C (during storage)

2. Installation environment

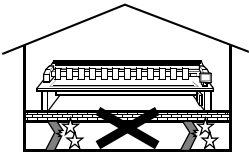

CAUTION

-  Install the machine on a sturdy floor.

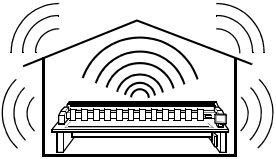

 The floor structure must be strong enough to bear the machine weight (indicated on the spec. plate). If the floor is supported by steel frames, place the machine stand on the steel beams as long as possible.

-  Control the operation noise in the environment.

 This machine is designed to reduce noise during operation. To improve the sound insulation performance in the factory still more, use the interior finish materials which show high sound insulating performance for the walls, ceiling, and floor of the factory.

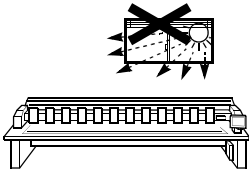

-  Avoid direct sunlight.

 If the machine is exposed to direct sunlight over an extended period of time, the machine body may be discolored or deformed. Put curtains or shades to the sight to prevent the machine from direct sunlight.

-  Provide enough space for maintenance.

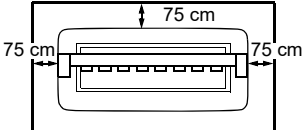
 Taking account of workability when maintaining and inspecting the machine, provide working space of 75 cm or more to right and left, and to 75 cm or more to rear direction for the machine against obstacles such as walls.





! Avoid dust and moisture.

Since dust and moisture lead to dirt and rust on the machine, use the machine in an environment of facility of air conditioner, and clean the working place periodically. Use caution not to expose the machine to direct wind from the air conditioner so that embroidery threads do not become disheveled.

Degree of pollution: 2 or less
 Humidity: 30 to 95%RH (relative humidity) without condensation
 Ambient temperature: 5 to 40°C (during operation)

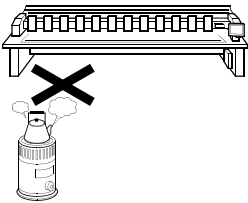

! Pay attention to interference of radio wave.

Although the machine is designed not to apply radio wave to other equipment, there could be cases where it causes radio wave interference depending on operation environment and type of equipment. If such problems arise, install the equipment as apart from the machine as possible.

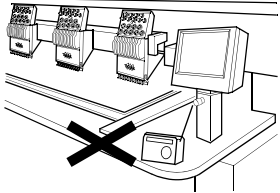

! Pay attention to power supply style.

When supplying the power, meet the following requirement.

- Excess voltage category: III

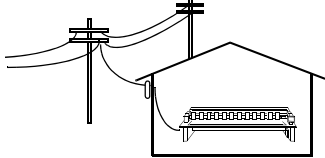

3. How to carry

3-1. When using a crane

! WARNING

! When suspending (lifting) the machine, make sure that there is no person standing in the danger area around the machine, especially under the machine.

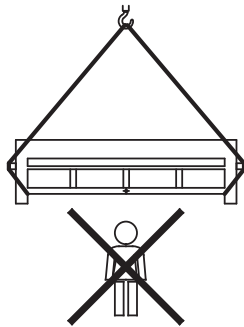

! WARNING

! When suspending the machine, use the square lumber as shown in the figure below, and make sure that the nylon sling does not touch the table. (section A)

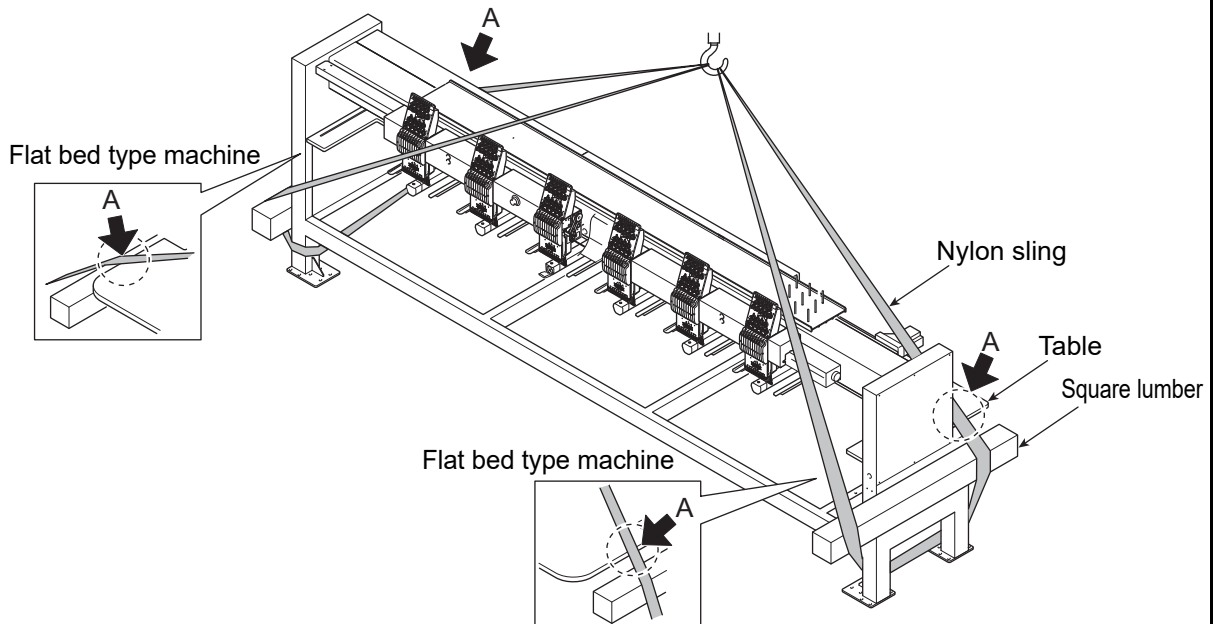

! WARNING

- !** When suspending the machine, use a nylon sling that is long enough to provide a sling angle of 50° or more so that the nylon slings do not touch the table.

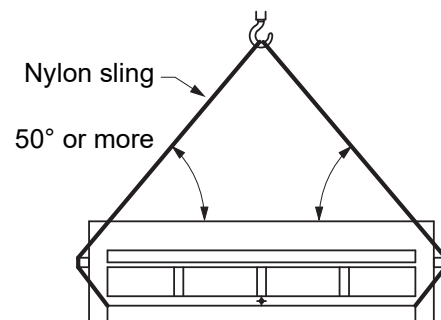
**3-2. When using a forklift****! WARNING**

- !** To lift the machine, check if there is no person around the dangerous zone of the machine, especially below the machine. Then, start working.

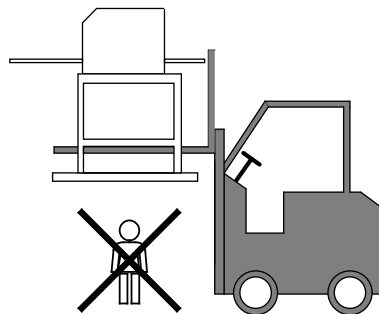

! WARNING

! When you use a forklift, pay enough attention not to drop the machine. Move the forklift to lift the machine with reference to "Gravity center mark" that shows right and left balance of the machine.

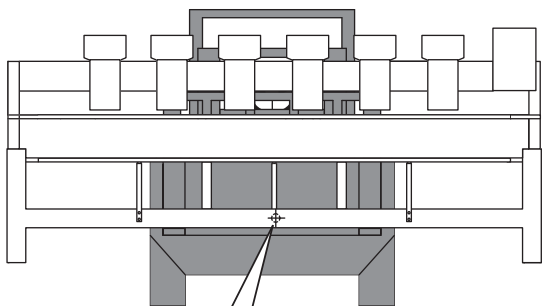

Gravity center mark

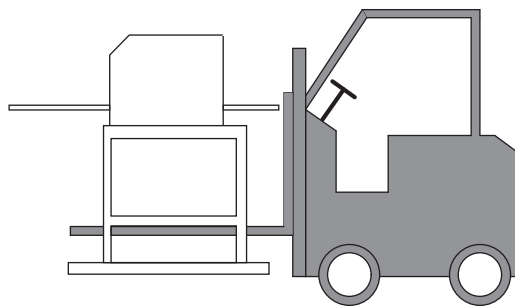
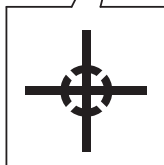

Chapter 2 Installation

WARNING

 Workers should understand the procedure thoroughly, and then start working. Unexpected action could cause injury.

1. Leveling bolt

1-1. In case of stand shape A

[Applicable models]

TFMX-IIC: 2H/360P、2H/500P、4H/360P

(1) Attach the caster 2 to the machine 1 with the screw 3 (hexagon socket head cap screw M8*25).

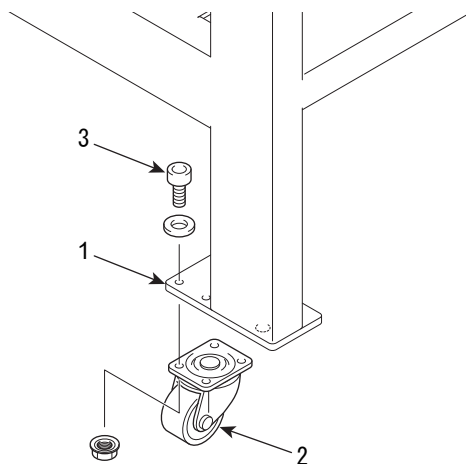

(2) Place the vibration-preventive base 4. Attach the leveling bolt 6 and the leveling block 7 to the machine 5.

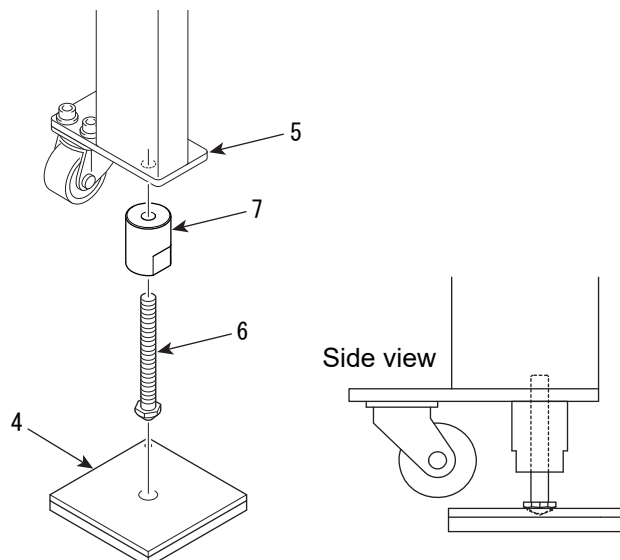

1-2. In case of stand shape B (with spacer)

[Applicable models]

TFMX-IIC: 4H/500P, 6H/360P

- (1) Insert the spacer 3 between the machine 1 and caster 2, and fix the machine 1 and caster 2 with the screw 4 (hexagon socket head cap screw M8*25).
- (2) Attach the stand frame 5 to the machine 1 with the screw 6 (hexagon socket head cap screw M8*25).

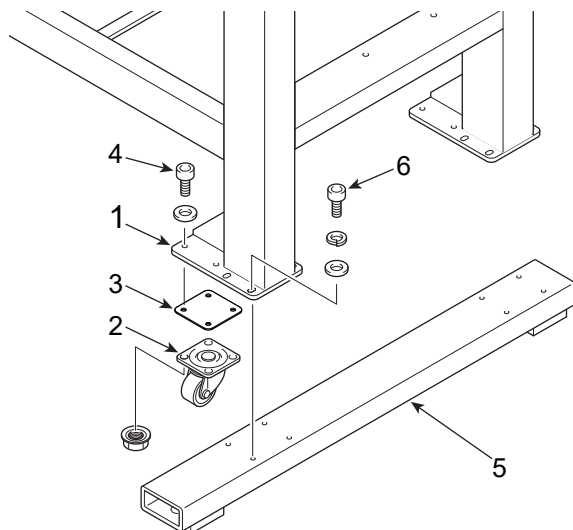

- (3) Place the vibration-preventive base 7 under the stand frame 5.
- (4) Insert the nut 8 into the stand frame 5, and screw the leveling bolts 9.

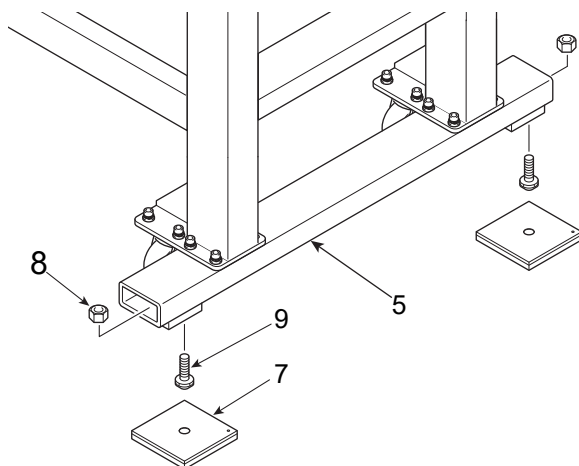

1-3. In case of stand shape B (without spacer)

[Applicable models]

TFMX-IIC: 6H/500P, 8H/360P, 8H/500P

- (1) Attach the caster 2 to the machine 1 with the screw 3 (hexagon socket head cap screw M8*25).
- (2) Attach the stand frame 4 to the machine 1 with the screw 5 (hexagon socket head cap screw M8*25).

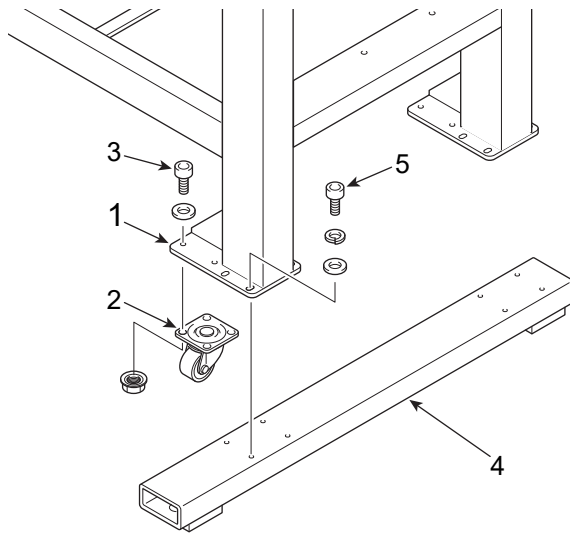

- (3) Place the vibration-preventive base 6 under the stand frame 4.
- (4) Insert the nut 7 into the stand frame 4 and screw the leveling bolts 8.

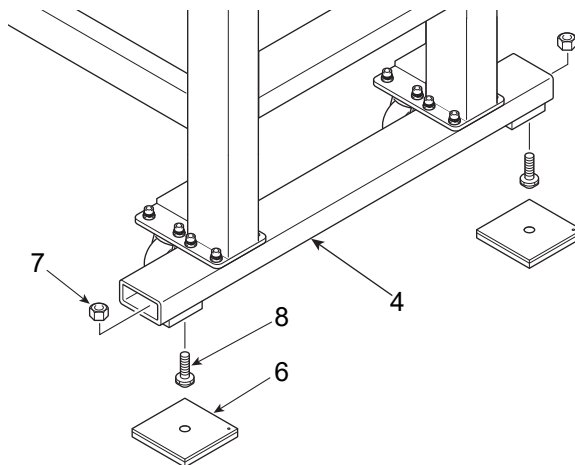

1-4. In case of stand shape C

[Applicable models]

TFMX-II, TFMX (L)

- (1)** Insert the nut 2 into the stand 1, and screw the leveling bolts 3.
- (2)** Put the stand 1 on the vibration-preventive base 4.

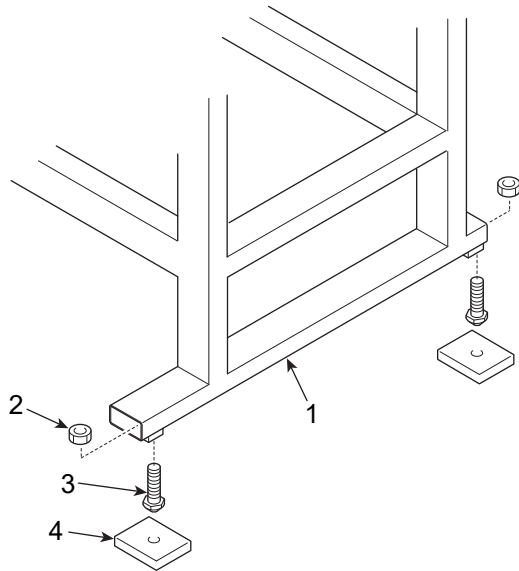

Chapter 3 Detaching, attaching

1. Detaching

1-1. Stopper

The attaching position of the stopper 1 differs depending on the model.

2H 360P/500P

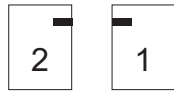

— Stopper

4H 360P/500P



6H 360P/500P

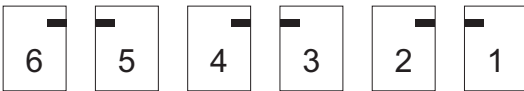

8H 360P/500P

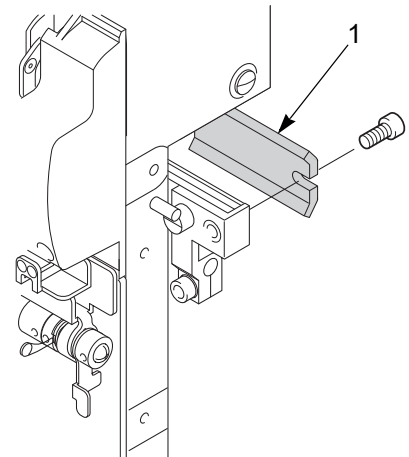

(1) Detach all the front cover 2 and check the attaching position of the stopper 1.

(2) Detach all the stopper 1.

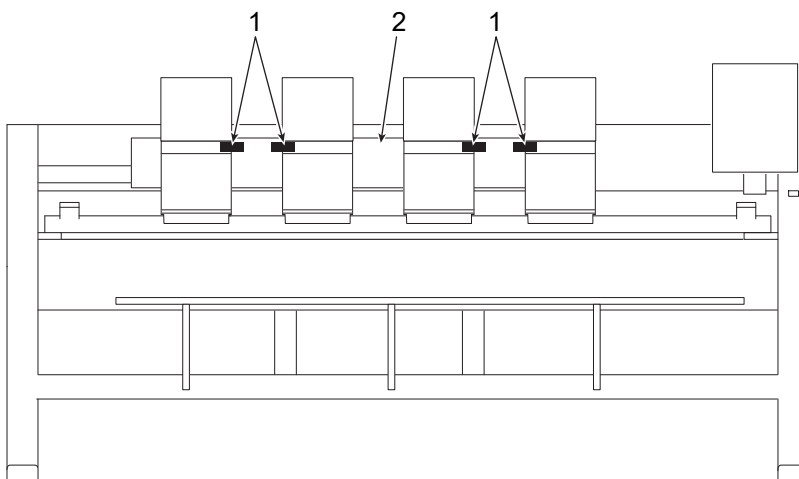

An example of 4-head machine

2. Attaching

2-1. Thread course

Attach the thread course by referring to the figure below.

(1) 12 or less needle machine

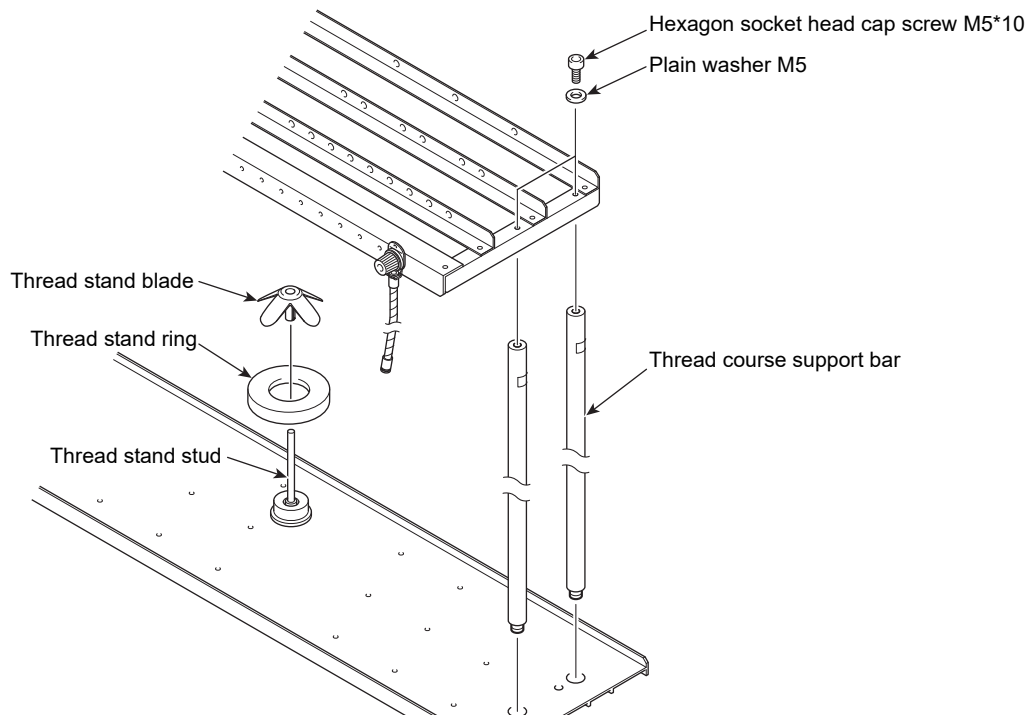

(2) 15-needle machine

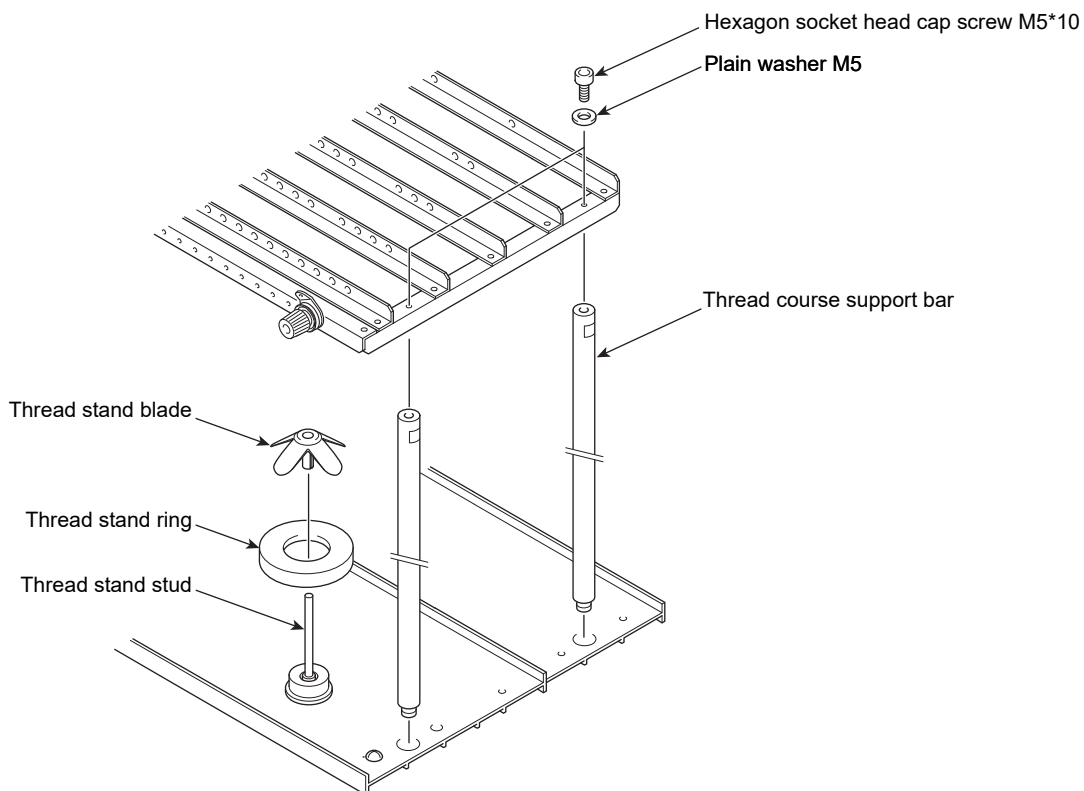

2-2. Operation panel (OP)

Attach the operation panel (OP) to the controller pipe, and connect harnesses. The harnesses connection differs depending on the specification.

Back face of the operation panel (OP)

Example of EN specification

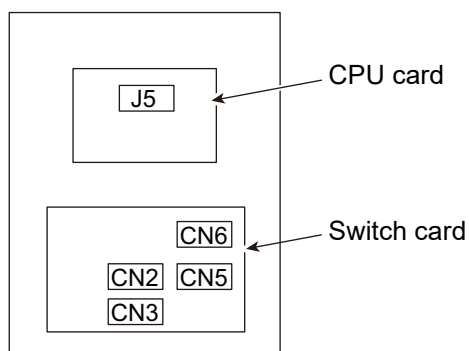
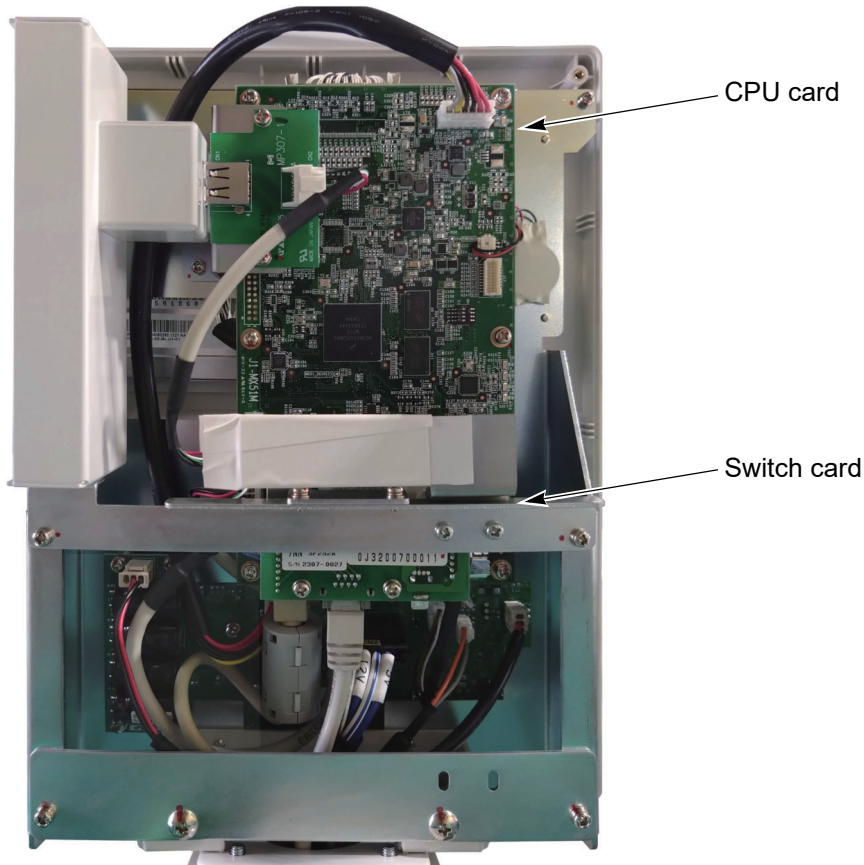

Connecting destination

Specification	CPU card	Switch card
CSA	J5	CN2, CN3, CN5
Standard ^[1] , UL, EN		CN2, CN3, CN5, CN6

[1] Countries other than UL, CSA & EN

2-3. Beam sensor (limited model)

The presence or the absence of the beam sensor depends on the specification.

Attach the reflector 1 and the beam sensor 2 by using screws 3 (hexagon socket head cap screw M4*8, spring washer M4 and plain washer M4).

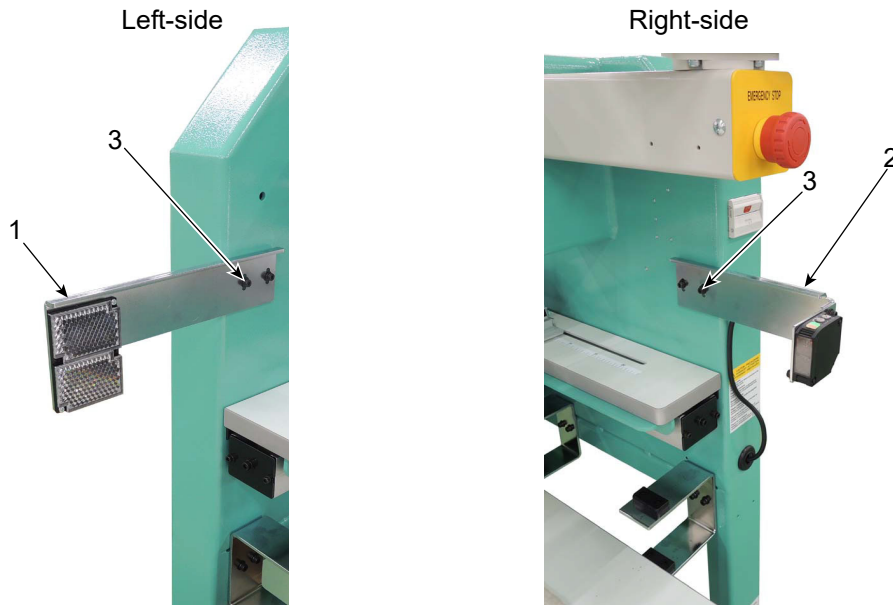

Attach the reflector 1 and the beam sensor 2 to the height of the following figure based on the upper surface 4 of the table.

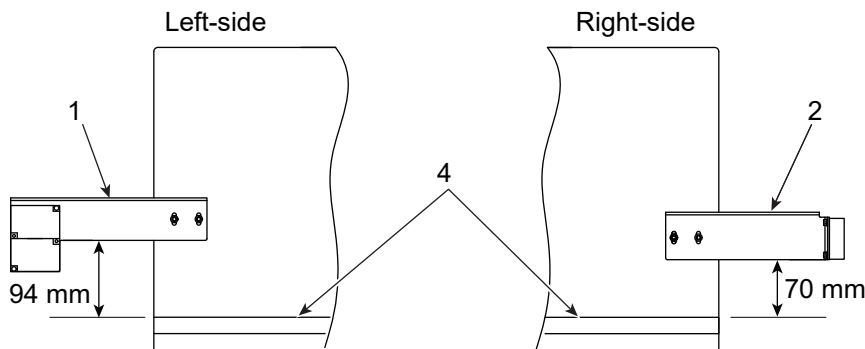

2-4. Lower unit of Sequin device III (Option)

For TFMX-IIC, attach the lower unit 1 that is packed separately with the machine by using screws 2 (Stepped screw M3*6).

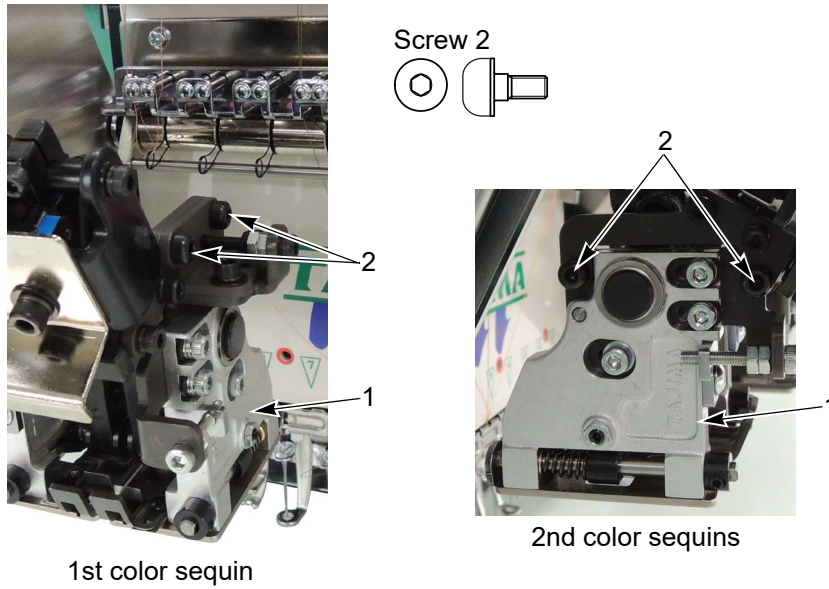



Chapter 4 Connection of power cord

1. Important safety instructions



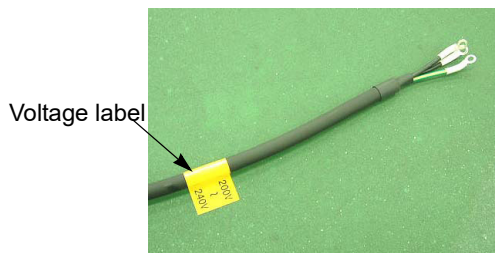
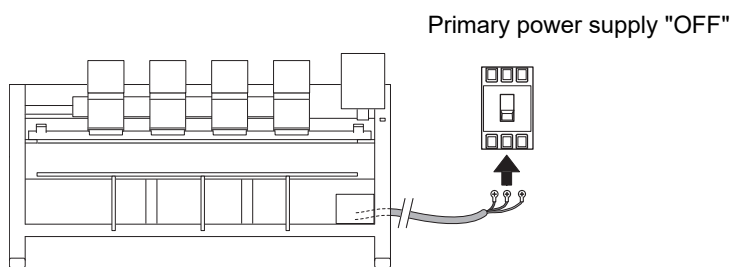

DANGER

-  When you connect the power cord, be sure to turn "OFF" the primary power supply. There could be a danger of electric shock, burning or death. In addition, check if the voltage of the voltage indicating label that is attached to the power cord fits to voltage spec. on your side, and then connect the power cord to the primary power supply.



-  If the machine needs to be connected to an external power supply, the power supply cable connection must be done only by the service personnel assigned and trained by TAJIMA or qualified technician.

WARNING

-  Do not use this product at voltages other than the rated voltage of the machine. Failure to do so may result in fire, electric shock, or malfunction.
-  When supplying the power, conform to excess voltage category "III".
-  Connect the machine to the power supply line that is not connected to machines subject to large load fluctuation such as elevators and presses so that the machine can operate in stable conditions.
-  Check if power voltage is enough for operating the machine by using a multimeter.
Voltage: Within $\pm 10\%$ of the rated voltage
-  The power supply cable must be laid out of the operator's moving area so that the operator does not step on the cable.

! WARNING

- ⚠ Insert the power cable plug fully. If a metallic part etc. touches a blade in the plug, it may cause fire and/or electric shock.
- ⚠ Since there is the danger of electric shock due to leak current, be sure to connect the grounding wire. In addition, degree of grounding should be type D or higher (grounding resistance 100 ohms or less).

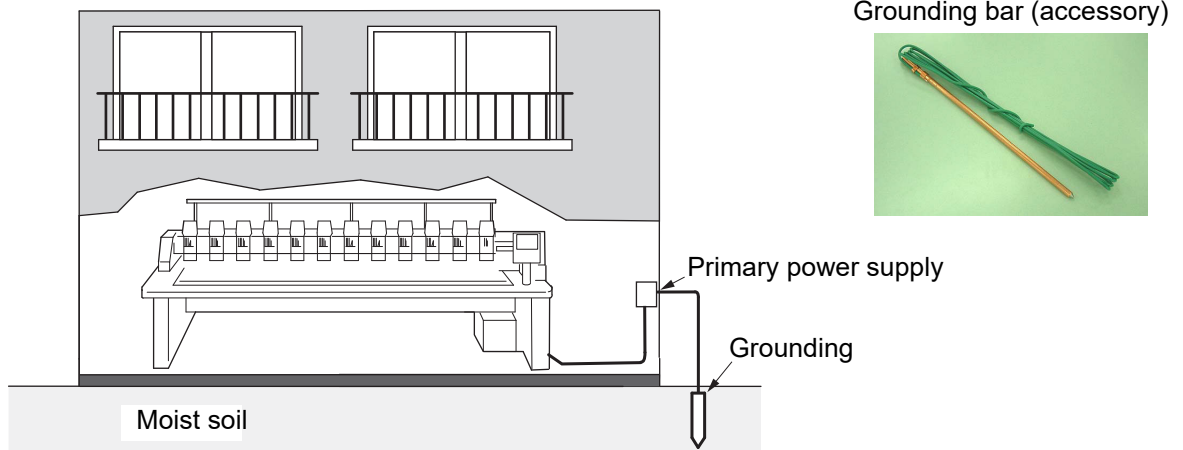

! CAUTION

- ! In addition to full-time leak current, leak electric current generated by harmonics and surge flows in the power cable of the machine. For this reason, if selection and installation of breaker of leak current and leak current relay used for the factory are not correct, malfunctioning of the machine may occur.
Regarding connection of power cord, observe the following items.
- ! Use a breaker of electric current leakage and leak current relay for which measures are taken against harmonics and surge. If such a breaker and a relay are not available, select conventional breaker and relay with sufficient leak current capacity to absorb leak current caused by harmonics and surge. (In this case, constant leak current must be controlled satisfactorily.)
- ! Regarding capacity of electric current leakage for breaker of electric current leakage and leak current relay per machine, please consult your local TAJIMA distributor.
- ! For actual product names of breaker of electric current leakage and leak current relay for which measures are taken against harmonics and surge, please consult your local TAJIMA distributor or electric engineers.
- ! To prevent the machine from property damages, one embroidery machine should be connected to one no fuse breaker. Property damages include a drop of output of the main shaft motor (MM), etc., stop position error and color change error caused by the stop position error, design displacement, etc.

2. Power cord

There are following types of power cord.

CAUTION

 Do not use a power cord other than the one provided. Failure to do so may result in fire, electric shock, or malfunction.

(1) Exclusive item for UL-spec. and CSA-spec.



(2) For Japanese domestic use

CAUTION

 When using a plug adapter, ground the ground wire.



Plug adapter

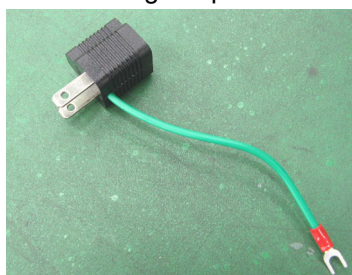

(3) Other cases than (1) and (2) described above

⚠ CAUTION

⚠ Attach a power cord to a plug with a grounding terminal that matches the outlet to be connected, and ground the ground wire.

Power cord



Chapter 5 Operation panel (OP) settings

1. Parameter setting

A parameter list is attached to the back of the operation panel (OP). Check setting values. At this moment, check also version of the software.

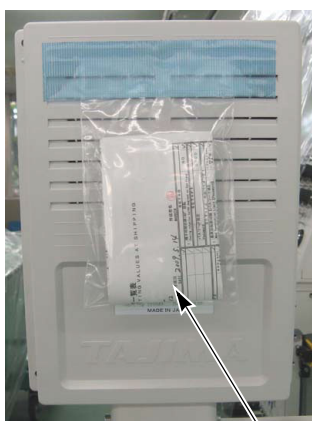

Regarding information about the latest version of software and how to obtain the software, consult the distributor.

"Parameter setting chart" at shipment from the factory is attached.

2. Frame Origin Memory

Frame origin is the anchoring point that calculates the current frame position. If the calculation is wrong, the following troubles will occur.

- (1) Frame coordinates are not displayed correctly.
- (2) The frame does not return to the interrupted position even after performing power resume operation.

Make this machine memorize the frame origin. Perform this operation in the following conditions.

- (1) When setting up the machine
- (2) When installing software
- (3) When replacing the frame, the embroidery frame might be moved with the power turned OFF.

2-1. TFMX-IIC, TFMX-II

After turning ON the power, the following message will appear. Then, press SET.

! CAUTION

⊘ When performing this operation, do not put your hands, etc. on the machine table. You could be injured by moving frame.

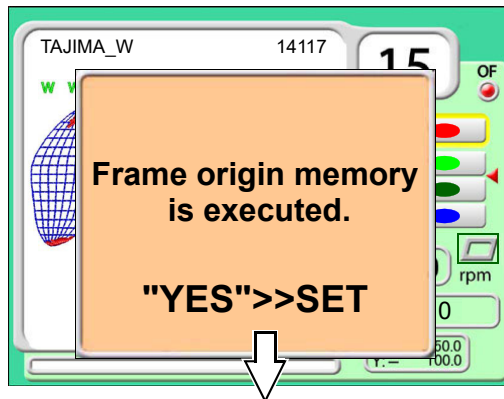

This operation is to grasp accurately the frame position and it is displayed every time when the power is turned ON.

This message will be displayed only when "Frame Origin Memory with the power-ON" is set to "YES".

SET



Press SET.

The frame will move and return to the original position.

2-2. TFMX (L)

[How to operate]

⚠ CAUTION

⊘ When performing this operation, do not put your hands, etc. on the machine table. You could be injured by moving frame.

(1) Set to main screen.

(2) Press F2 key while pressing SET key.

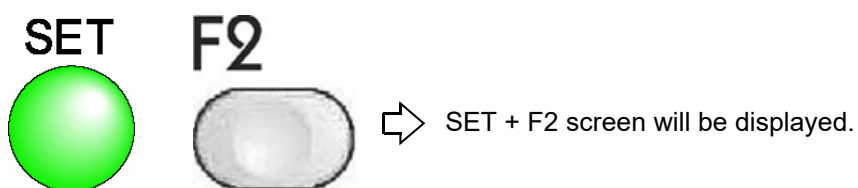

(3) Press F2 key.

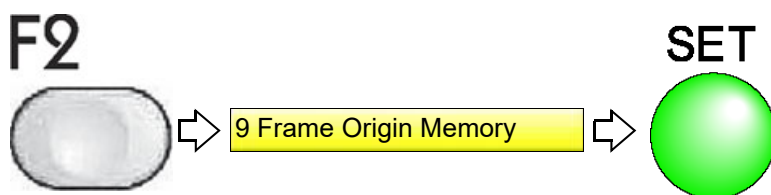

(4) Execute Frame Origin Memory.

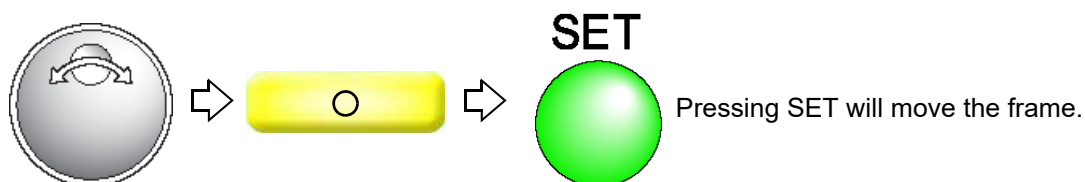

Chapter 6 Level adjustment

1. Level adjustment

- (1) Install the machine using a level gauge 1 to check leveling so that there is neither slant nor contortion. There are four spots for measurement.

Leveling in right and left direction

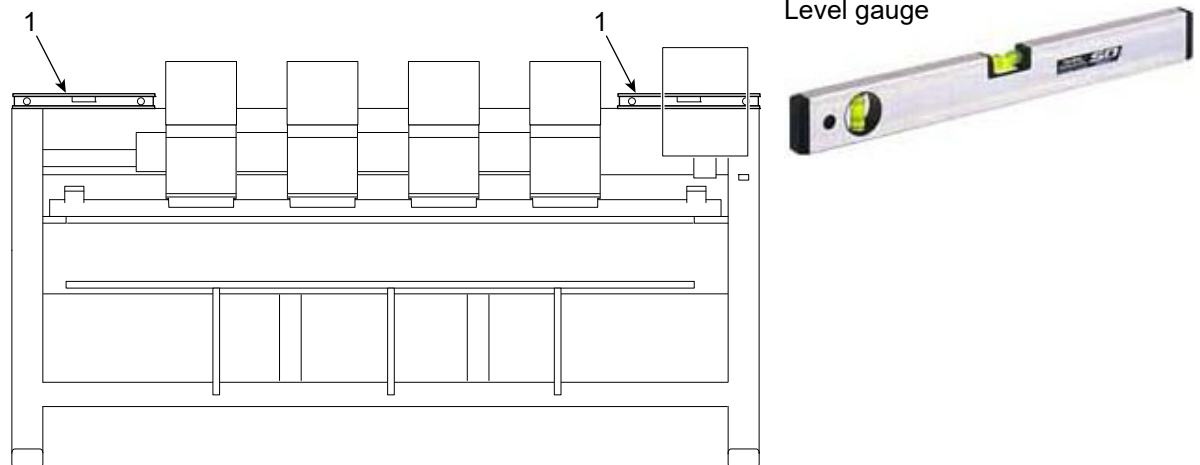

- (2) Level adjustment in front and rear direction

Attach the magnet holder 2 so that its corner comes to the center of the punching mark 3. Place the level gauge 1 on the magnet holder 2.

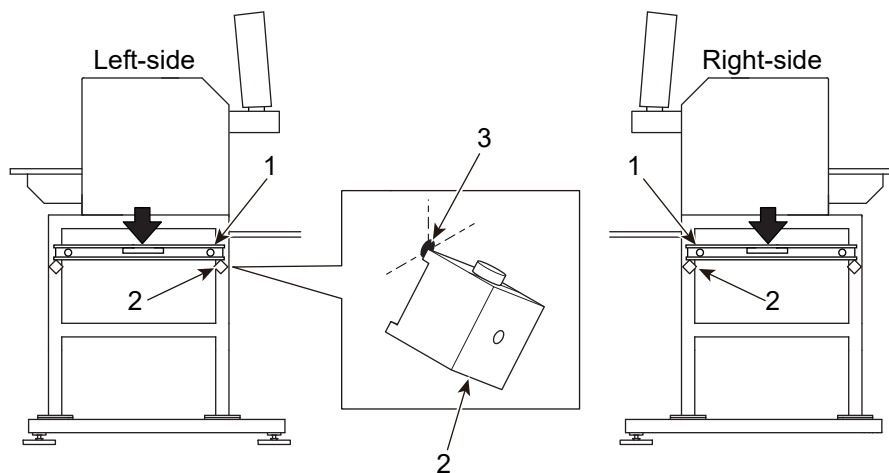

- (3)** Adjust two leveling bolts 4 on a diagonal line while checking bubble of the level gauge, and adjust the remaining two leveling bolts 5 next. Then, tighten nuts 6. At this time, adjust so that tightening effectiveness (load) of four hexagon bolts becomes equal.

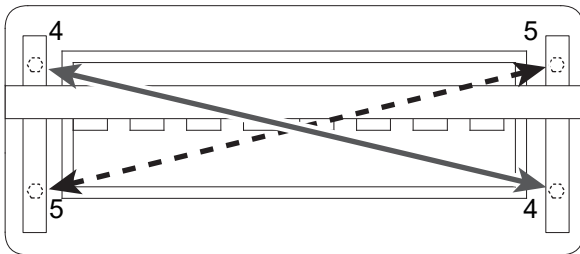

If a bubble is set within the range (inner lines) of a level gauge with its sensitivity of 0.5 mm/m, the degree of level becomes "±0.5°".

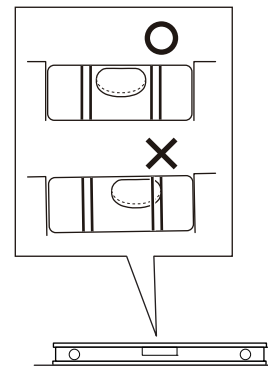
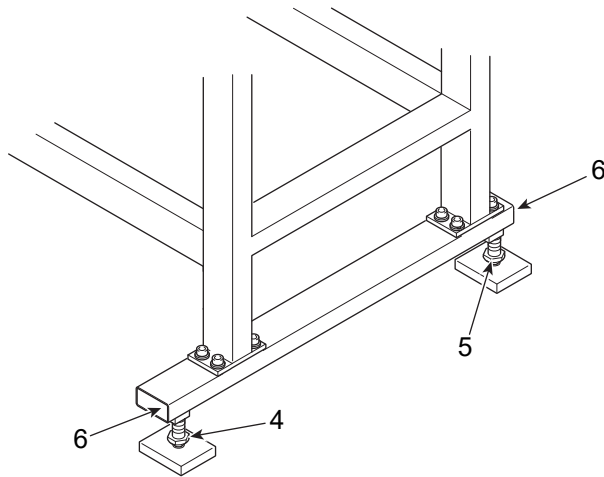

2. Attaching of center support (limited model)

! CAUTION

⊘ Do not lift the center support too much. Lifting too much would change the needle bar lower dead point and the needle locating position, which could affect sewing badly.

- (1) In some models, attach the center support to the center of the stand (back and forth two spots).

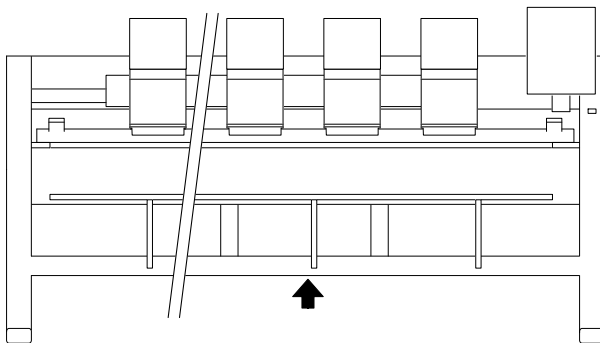

Center support (accessory)



- (2) After making 1/4 turn using a wrench from the position where the adjusting bolt 1 touches the dent of the vibration-preventive base 2, tighten the nut 3. When vibration, noise etc. occur, adjust tightening degree of the adjusting bolt 1 accordingly.

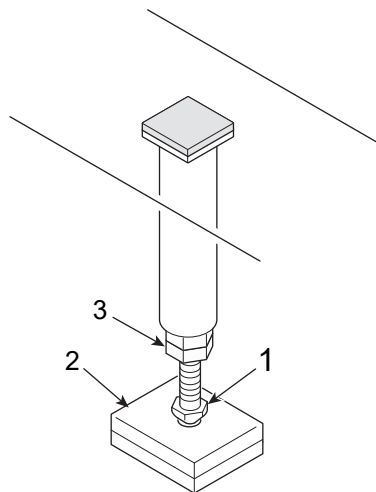

Chapter 7 Adjustments

1. Needle locating position

Perform this checking at the first needle and the last needle.

- (1) Turn the main shaft counterclockwise to set the main shaft angle to 178° (Needle bar lower dead point).



To rotate the main shaft, use the main shaft handle 1.

- (2) Lower the needle bar by hand.
- (3) Check if the needle 2 is almost located at the center of the needle hole 3.

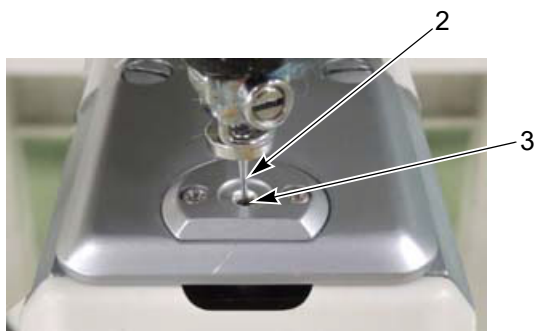

- (4) Set the main shaft angle to 100° (Stop position).
- (5) Perform Color Change to the last needle to check the needle locating position.

- (6) Loosen screws 4 (two spots at the right and left sides), slide the needle bar case to right and left, and adjust the needle locating position.

TFMX(L)、TFMX- II



4

TFMX- II C

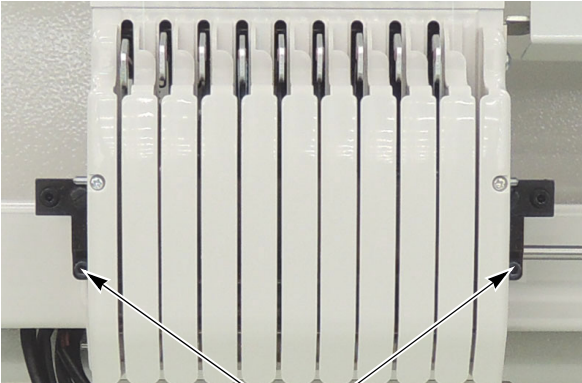

4



2. Lower dead point

Perform this adjustment from the 1st needle to the last needle (All needle bars).

- (1) Turn the main shaft counterclockwise to set the main shaft angle to 178° (Needle bar lower dead point).

To fix the main shaft, thrust the hexagon socket head cap screw (M6*35) 2 into the hole 1 of the timing pulley. After the work is finished, be sure to remove the hexagon socket head cap screw (M6*35) 2 before turning ON the power.

Left-side box

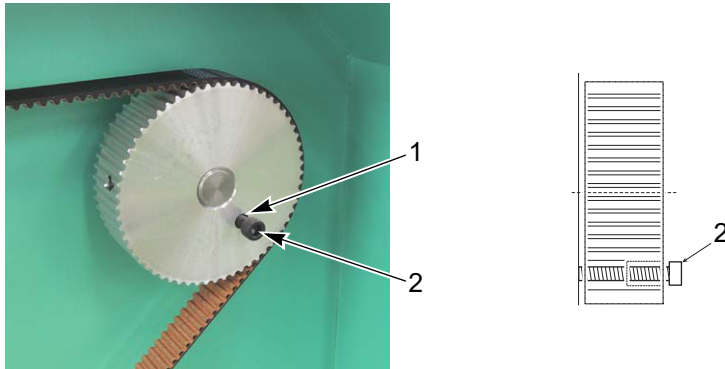

- (2) Lower the needle bar by hand.

- (3) As shown below, put the lower dead point gauge so that the needle comes into the groove. At this moment, check if there is no play at up and down direction. There are two types of lower dead point gauge (TAJIMA B and TAJIMA). Do not confuse them.

TFMX-II, TFMX (L)



Engraved mark
TAJIMA B

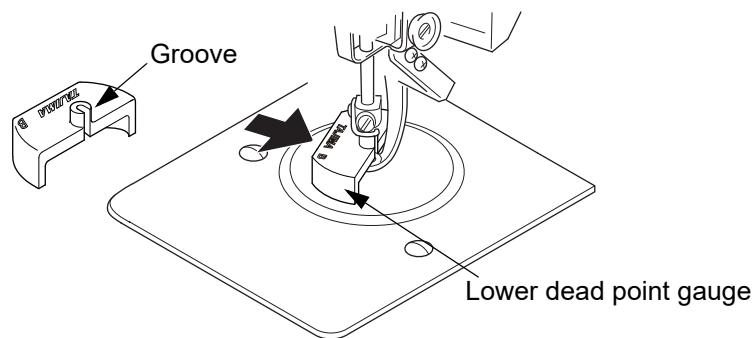

TFMX-IIC



Engraved mark
TAJIMA

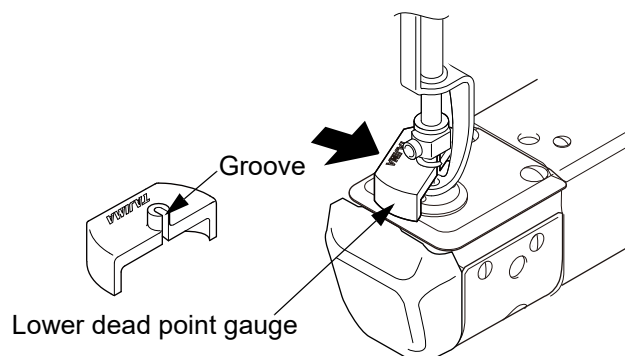

- (4) Loosen the screw 1, and push down the needle bar 2 to touch to the lower dead point gauge 3. Tighten the screw 1 in the state that the needle clamp 4 faces as shown in the photo A.

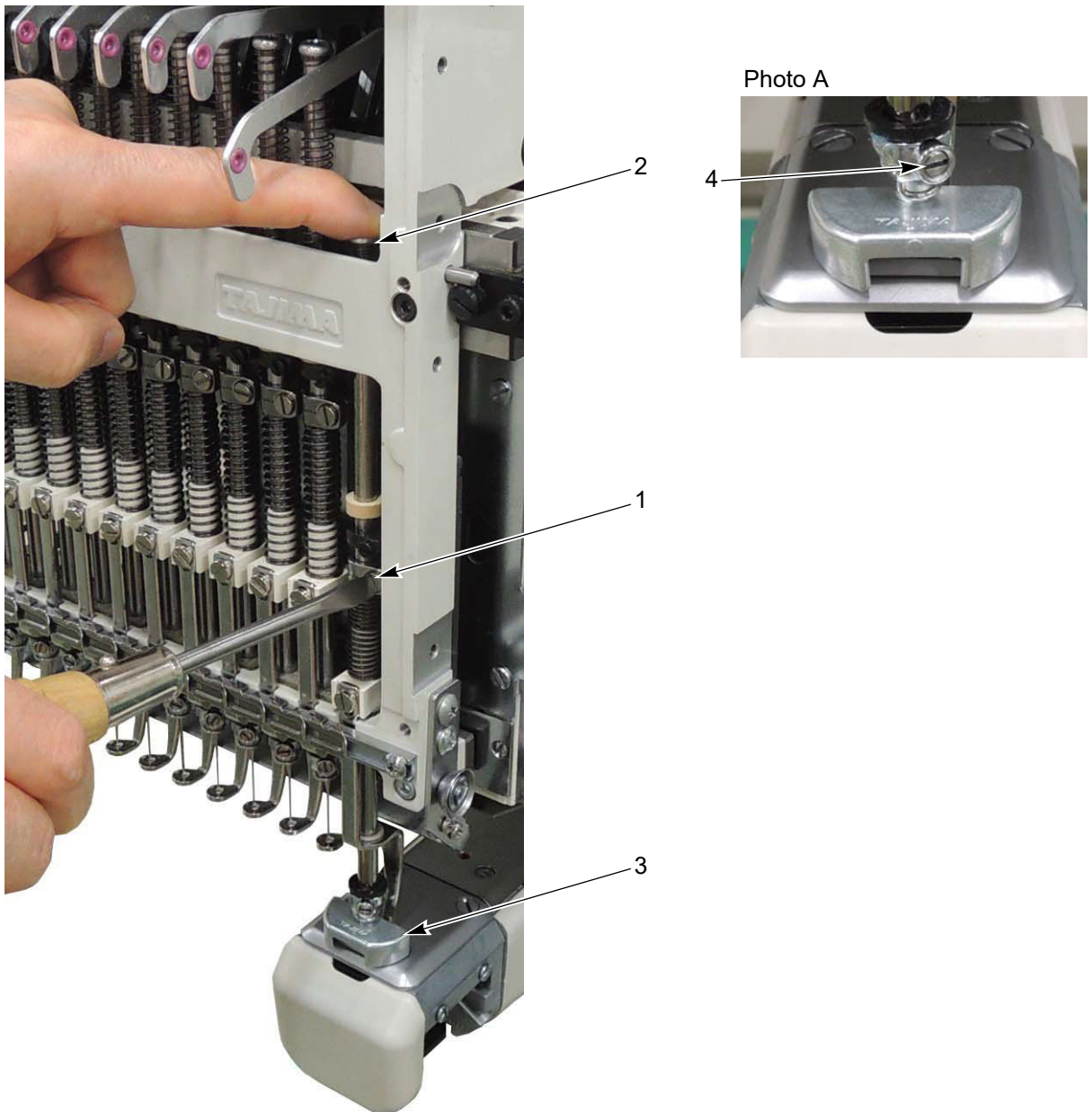

- (5) Detach the lower dead point gauge, and set the main shaft angle to 100° (Stop position).
 (6) Perform Color Change to the next needle bar.

- (7) Attach the connecting stud gauge 5 to the needle bar of the 1st needle. Loosen the wing screw 6 and then tighten it with no gap between sections A and B.

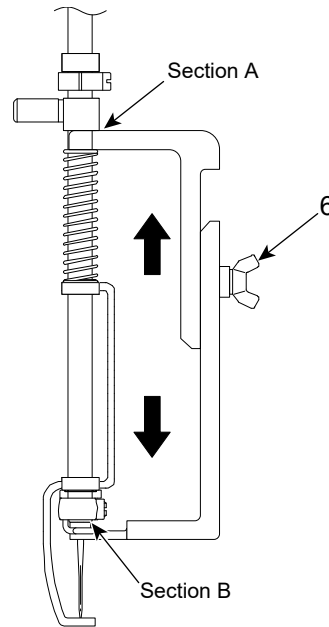
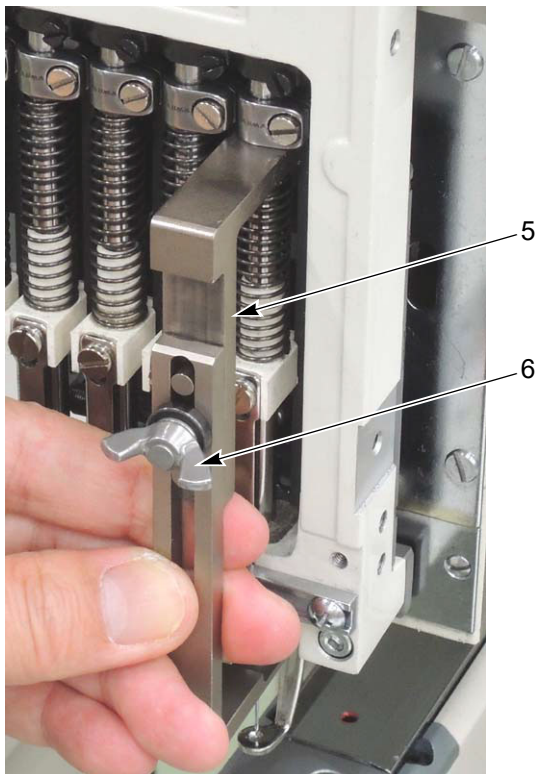

- (8) Attach the connecting stud gauge 5 to the 2nd needle. Loosen the screw 7, and tighten the screw 7 with no gap between section A and B.

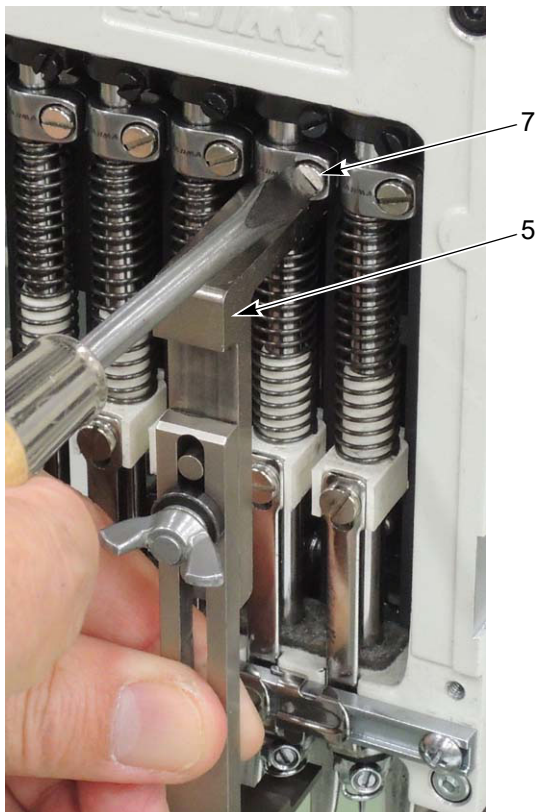

Perform working of the 2nd needle and after to the last needle.

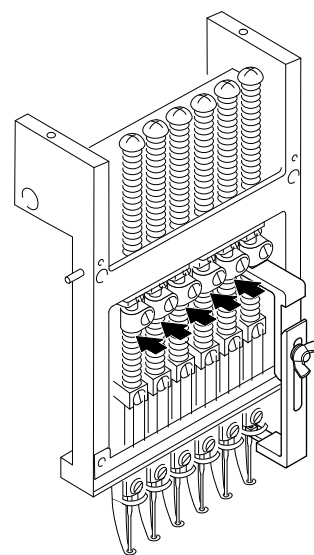

3. Upper dead point

- (1) Turn the main shaft clockwise to set the main shaft angle to 7°.

Although the upper dead point of this machine is 0°, the upper dead point stopper 1 is fixed at the position where the upper dead point stopper 1 touches the cushion ring 2 at main shaft angle 7° in production at the factory.

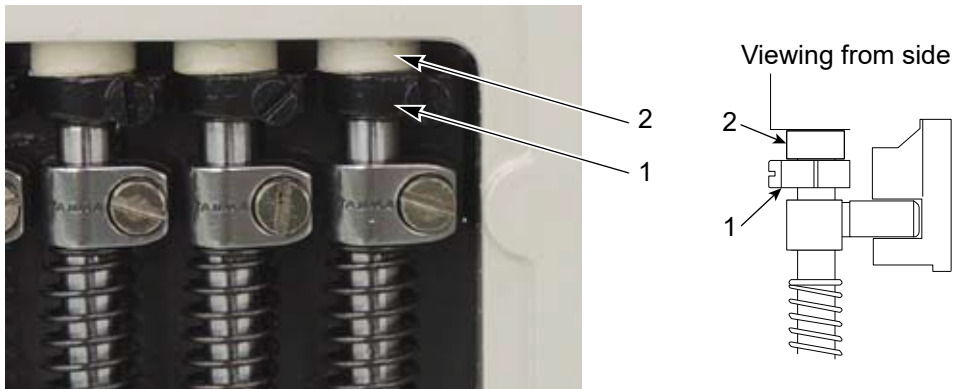

- (2) Loosen the screw 3 of the upper dead point stopper 1.

Tighten the screw 3 in the state of the upper dead point stopper 1 lightly touched to the cushion ring 2.

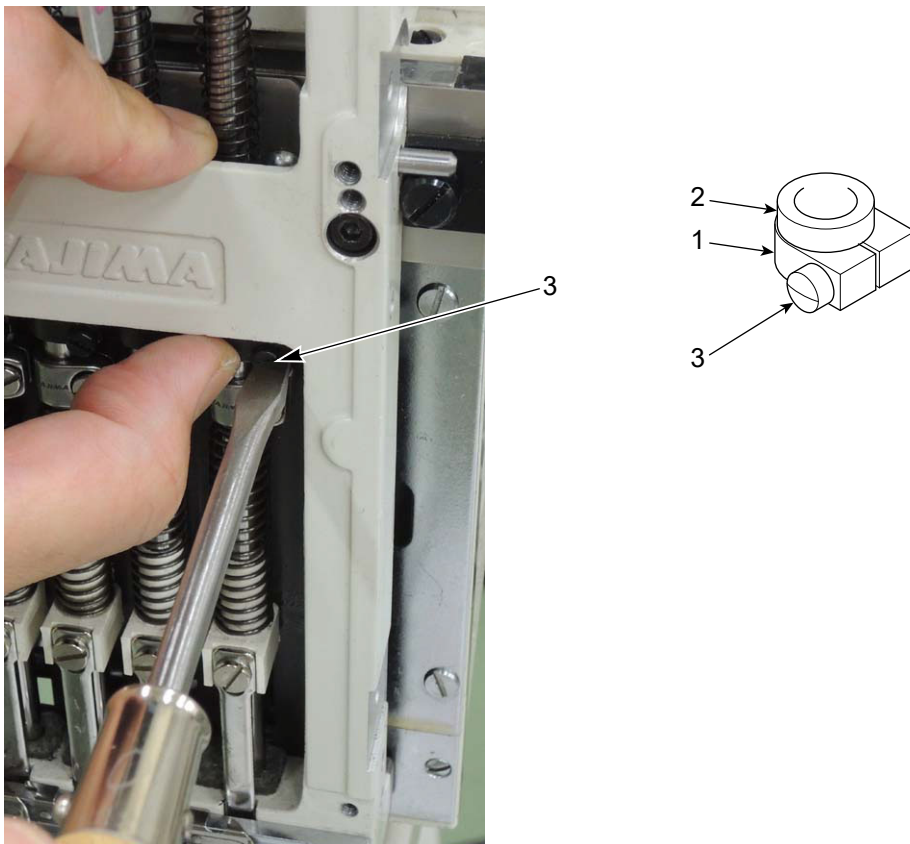

4. Bevel gear

Check "Play" between the bevel gear 1 and the bevel gear 2. If the bevel gear 2 moves slightly (0.1 to 0.2 mm), "Play" is normal.

If there is no "Play", loosen the set screw 3 of the bevel gear 1 to adjust the position of the bevel gear 1.

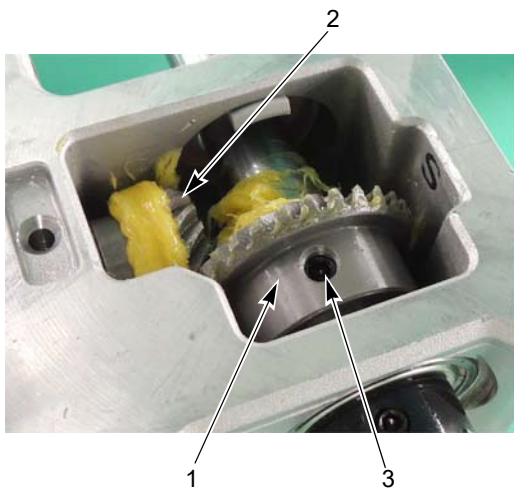
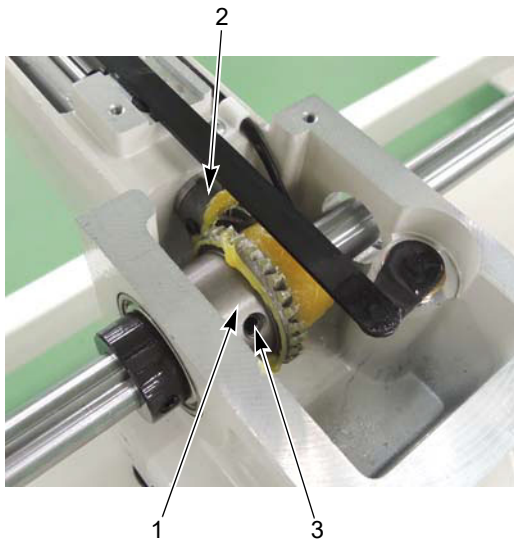

5. Needle and rotary hook

Perform this checking at the first needle and the last needle.

- (1) Turn the main shaft counterclockwise and set it to the position (200° to 201°) where the needle tip 1 meets the hook point of rotary hook 2.
- (2) Check if the gap (A) between the scarf 3 of needle and the hook point 2 of rotary hook is 0.1 to 0.3 mm.

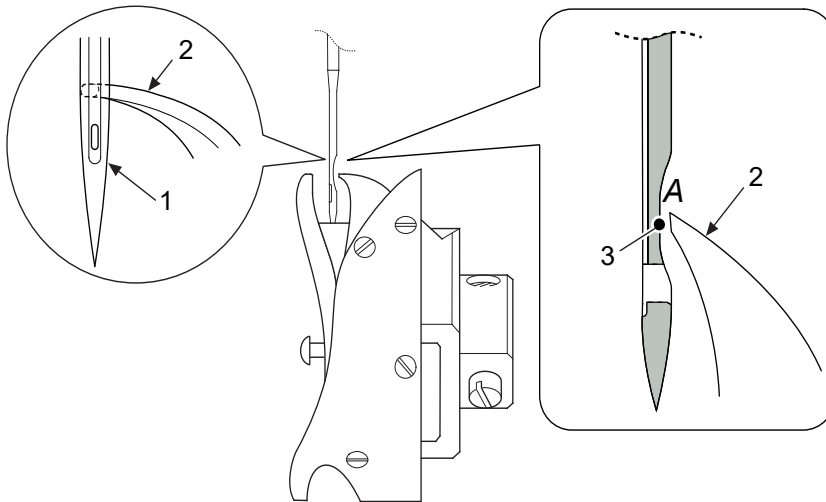

Push the needle lightly using a flat head driver.



Chapter 8 Idling and test sewing

1. Lubrication

! CAUTION

- ! When performing lubrication, use only Tajima's genuine TF oil (packed with the machine). If you use other oil than this by necessity, select oil equivalent to ISO viscosity grade: VG20.
- ! After the working, attach all covers that were detached.

1-1. Rotary hook

To lubricate, use the oiler (accessory). Lubricating spots are raceway 1 and lubrication hole 2.



To lubricate lubrication hole, attach the nozzle 3 (accessory) to the tip of the oiler.

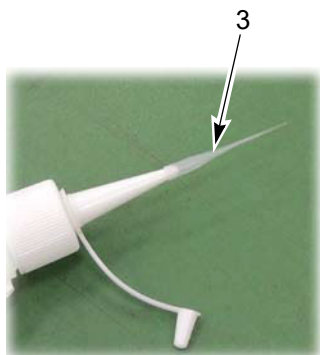

1-2. Inside of arm and cylinder bed

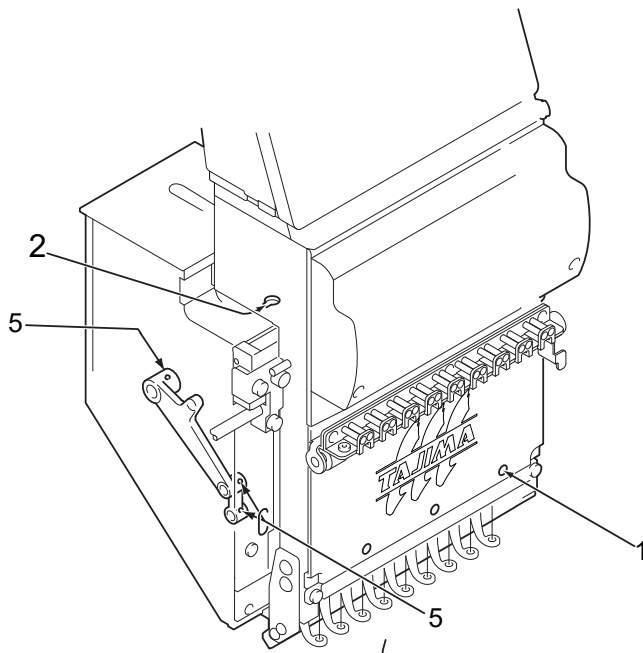

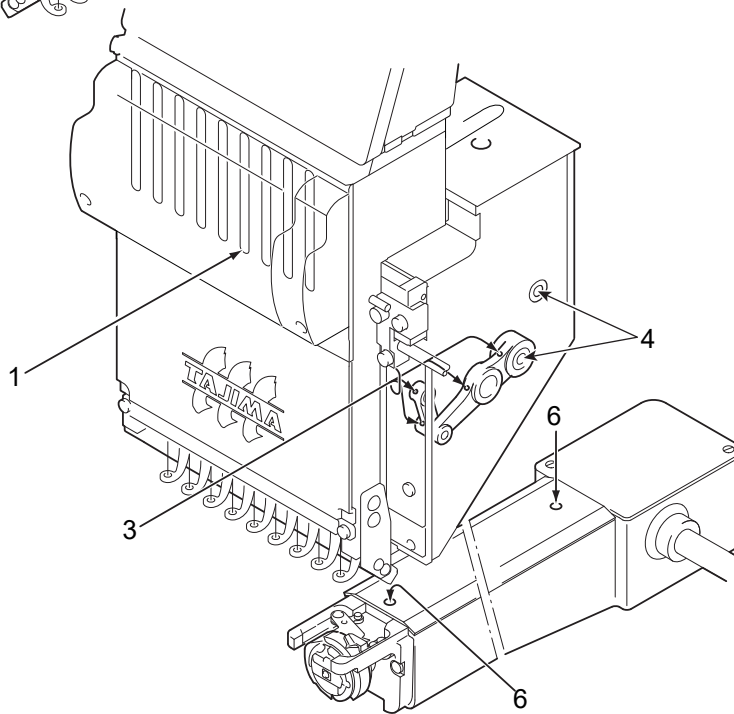

Lubricating spot
1: Needle bar
2: Needle bar drive shaft
3: Needle bar lever, connecting rod
4: Stepped pin of wick
5: Presser foot lever, connecting rod
6: Inside of cylinder bed



2. Idling, jump

CAUTION

-  When operating the machine, check if there is no person around moving section and all covers are attached to prevent accident resulting in injury or death.
-  Keep on idling until antirust applied on rotary hook is completely removed. If antirust remains, it could cause thread breakage.

- (1) Set "Upper thread breakage detection" and "Under thread breakage detection" to "not to detect" in parameter setting.

Operation on the operation panel (OP): Set by using F2▶6 .

- (2) Execute the data set of the design data containing jump codes.
- (3) Start the machine to perform idling. At the beginning, start the machine with about 250 rpm or so and increase the speed up to 650 rpm while checking running condition of the machine. Spare time for 20 to 30 minutes for operation. Check if no misjumping occurs using design data that includes jump codes.
When misjumping occurs, it is necessary to adjust the position of the upper dead point stopper.
- (4) After the working, check if no heat occurs from the side part of the arm, the needle bar drive shaft, etc.

3. Threader

Threading at tension part (indicated by arrows) affects finishing of embroidering. Therefore, thread correctly.

Threading through spiral tube

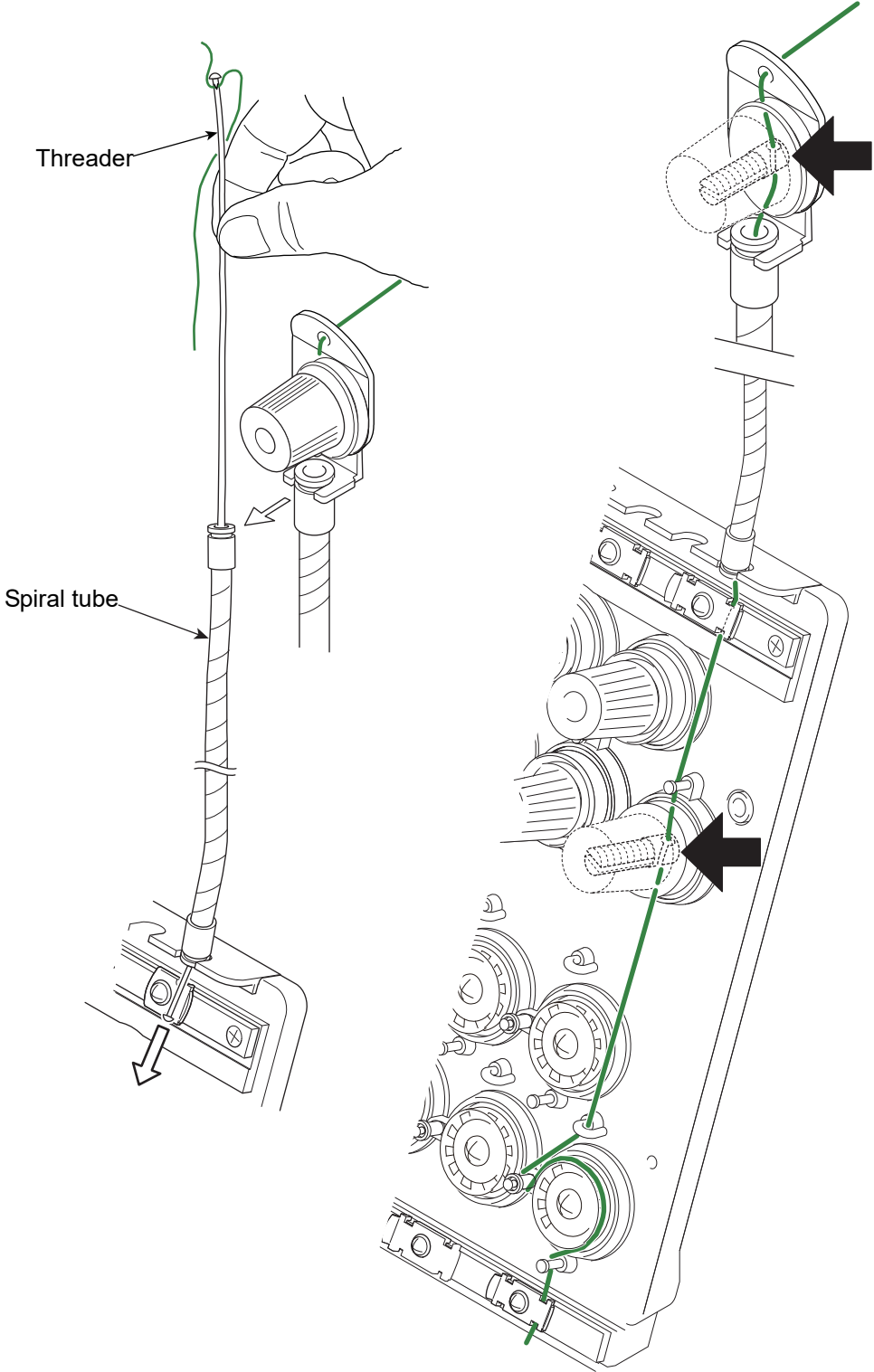

[TFMX (L), TLMX (L)]

! CAUTION

- !** Pass the thread to the thread take-up spring and the upper thread lock surely. Otherwise thread breakage would be caused or the thread tension would be affected badly.
- !** Return the adjusting lever to the original position after passing the thread. Otherwise thread breakage would be caused or the thread tension would be affected badly.

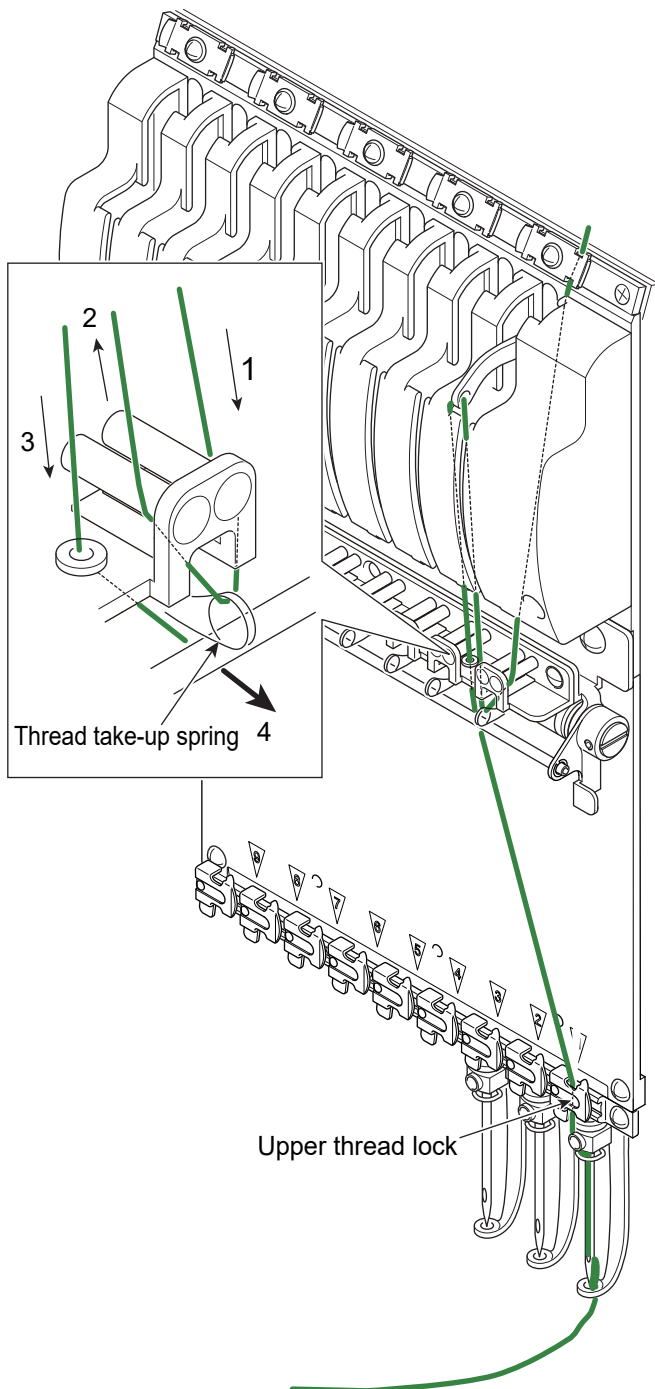

How to use adjusting lever

(1) Raise the lever.

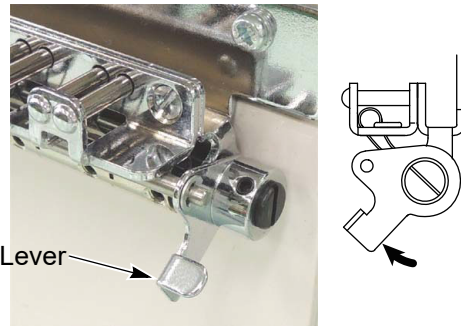

(2) Thread passing

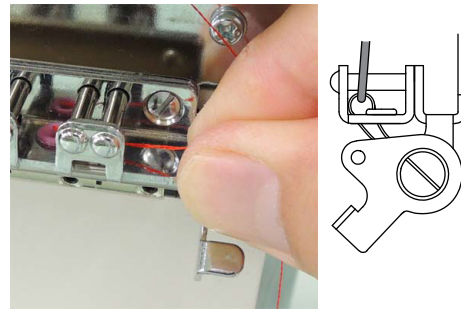

(3) After threading, return the lever. (The screw should face the front.)

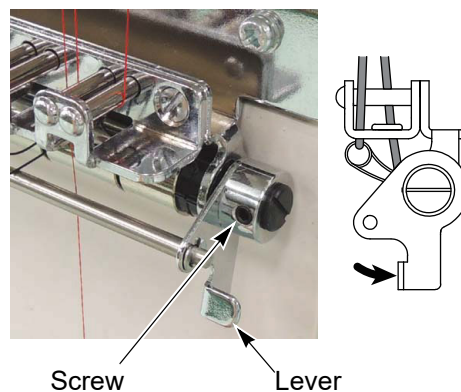

[TFMX- II C]

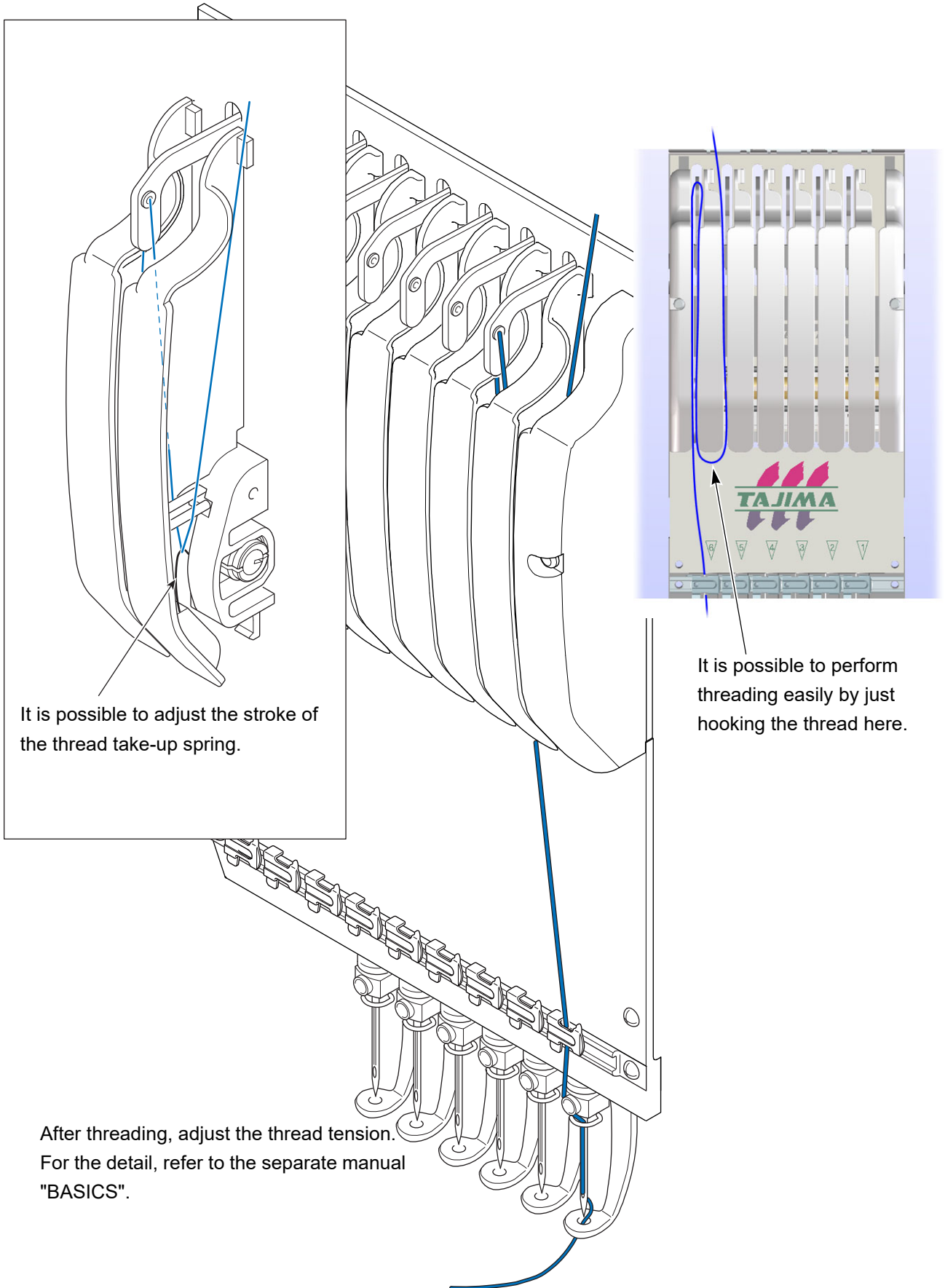

4. Test sewing

Stretch fabric to the frame, set the under thread bobbin and check each movement such as color change, manual ATH etc. Then, start test sewing.

CAUTION

-  For long life machine operation, operate the machine with about 70% of the maximum speed as "Operation for total fitting" for about two weeks after installation. By performing operation for total fitting, life of the machine will become longer, which will be useful to avoid unexpected troubles.

1st Edition April, 2013

24th Edition June, 2024

■ **Manufactured by: TISM Co.,Ltd.**

Address : NO.1800, Ushiyama-cho, Kasugai, Aichi-pref., 486-0901, Japan
TEL : 81-568-33-1161 Fax : 81-568-33-1191

■ **Distributed by: Tajima Industries Ltd.**

Address : NO.1800, Ushiyama-cho, Kasugai, Aichi-pref., 486-0901, Japan
TEL : 81-568-37-1130 Fax : 81-568-37-1230

●**Copy, reprint, or reform of a part or whole of this manual without permission is prohibited.**