

MACHINE SETUP INSTRUCTIONS

TLMX SERIES

[IMPORTANT]

**To handle the machine correctly and safely,
perform operations according to the procedure
described in this manual.**



User's Manual / Parts List

User's manual / Parts list are stored as the PDF file in the accessory DVD.

Please read the contents thoroughly and then use the machine or the optional device.

To see the PDF file, "Adobe Acrobat Reader" is necessary.

User's manual, parts list of the optional devices you have not purchased are included in this DVD.

Please note beforehand.

[How to open the DVD]

1. Insert a DVD into the personal computer.



Since the following pop-up window will be displayed automatically, select "Open folder to view files" (indicated by the arrow).

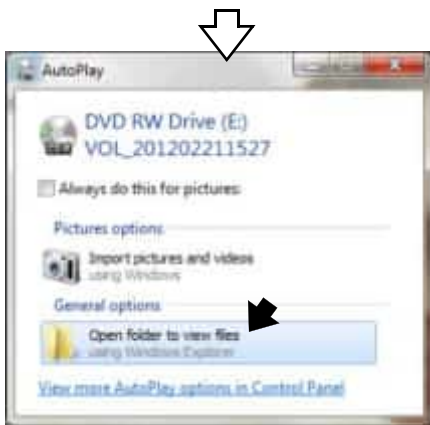

2. Double-click left "titlepage".

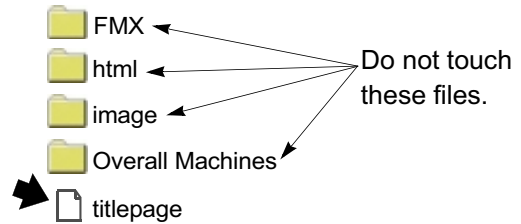

3. Select displaying language.



4. Select "User's Manual" or "Parts List", and then select the title you desire.



The figure above is an example selecting "English (Multiple Languages)" in the above 3.

Foreword

This manual introduces the procedure for setup of TAJIMA embroidery machine TLMX series.

Please read this manual thoroughly and operate the machine after you understand the contents.

This manual may contain discrepancies in detailed specification as compared with the actual production.

If you have any question about this manual, consult your TAJIMA distributor.

Regarding the optional device, refer to the USER'S MANUAL for the device (separate volume) .

Please keep this manual with care near the machine for quick reference.

TISM Co.,Ltd.

SAFETY PRECAUTIONS

To prevent any harm or damage to the person who use this product or other person, we describe items that must be surely followed as below.



Indicates that there is a lot of danger of death or serious injuries [*1] if handled by mistake.



Indicates that there is a likelihood of death or serious injuries [*1] if handled by mistake.





Indicates a potentially hazardous situation which may result in minor or moderate injury [*2] or property damage if handled by mistake.

*1: A condition caused by electric shock, injury, fracture of a bone, etc., that leads to aftereffects, or an injury that necessitates hospitalization or visits to a hospital over a long period.

*2: An injury that does not necessitate hospitalization or visit to a hospital over a long period.

: Prohibited items

: Items that may cause electric shock if not observed















: Items that must be followed carefully to ensure safe operation

1. Safety Precautions

1-1. Warning





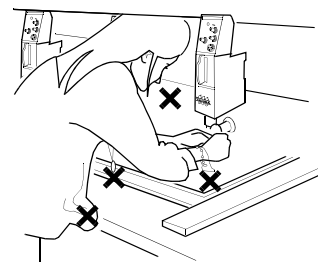
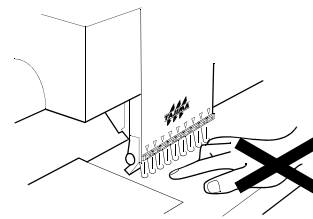

To prevent accidents resulting in injury or death and physical damage, the following items must be observed strictly when operating the machine.

WARNING

-  This machine is designed for industrial use. Use this machine for semi- or finished textile products and similar materials. Using the machine for other purposes must be avoided.
-  Do not stand on the machine.
-  For the machine model with the bar switch, using the bar switch as a grip to support yourself is strictly prohibited.
-  Do not use a device such as a cellular phone that generates microwave near the control circuits of the power supply box, the operation panel box, etc. Microwave may cause malfunctioning of the machine.
-  Do not remove the covers for the shaft and the pulleys. Also, do not run the machine without the covers.
-  Do not have your hands, etc. access to the vicinity of needle during operation. Sticking of needle could injure you.
-  During operation, do not access your hands and/or face to moving sections. Especially, it is dangerous around needle, rotary hook, take-up lever, pulley and speed-reduction box.
-  This machine uses strong magnet. The person, who is mounted with internal implantable medical electronics like a pacemaker, should not use this machine. The person who is mounted with a equipment described above also should not access to magnet inside of this machine. This internal equipment could malfunction.
-  Please read this book thoroughly and understand the contents of operation certainly. Then, operate the machine.
-  Wear proper clothes and tidy up yourself so that you can smoothly perform the operation.
-  A single operator should operate the machine in principle. If plural operators are working together, make sure that no one is working near the moving units of the machine before starting the machine.
-  Use the machine under the environment where access can be supervised so that unauthorized person does not operate the machine. Supervise children so that they do not access to the machine.
-  Only the persons who are sufficiently trained for the operation must operate the machine.
-  The rear of the machine is not a working area. If you have to move to the rear of the machine, make sure to turn off the main switch.



 **WARNING**

-  Stop the machine before threading into the needle and checking the finish of embroidery.
-  For the machine model with the sub table, lift up and fix the sub table securely after threading and/or adjusting the machine.
-  Do not damage, modify or heat the power or other cables. Do not exert undue force to them, either. Otherwise the cables will be damaged causing fire and electric shock.
-  Insert the power cable plug fully. If a metallic part touches a blade in the plug, it may cause fire and/or electric shock.
-  Keep away electrical units from water and chemicals. Entry or splashing of them into electrical units leads to short circuits, causing fire, electric shock and other troubles. If water or other chemicals enter the unit, Turn off the power switch, shut off the primary power of the machine and contact your local distributor.
-  Before opening the electrical boxes, be sure to turn off the power switch of the machine and shut off the primary power. If not, it may cause electric shock.

2. Warning labels

The machine has warning labels that bear instructions for safe operation. When using the machine, machine operators must follow the instructions shown on the warning labels.

Do not detach the warning label nor make the printing surface illegible by paint etc. If the warning label is missed or damaged, contact your local distributor.

The figure below is an example of attaching warning labels for TLMX-mixed type.

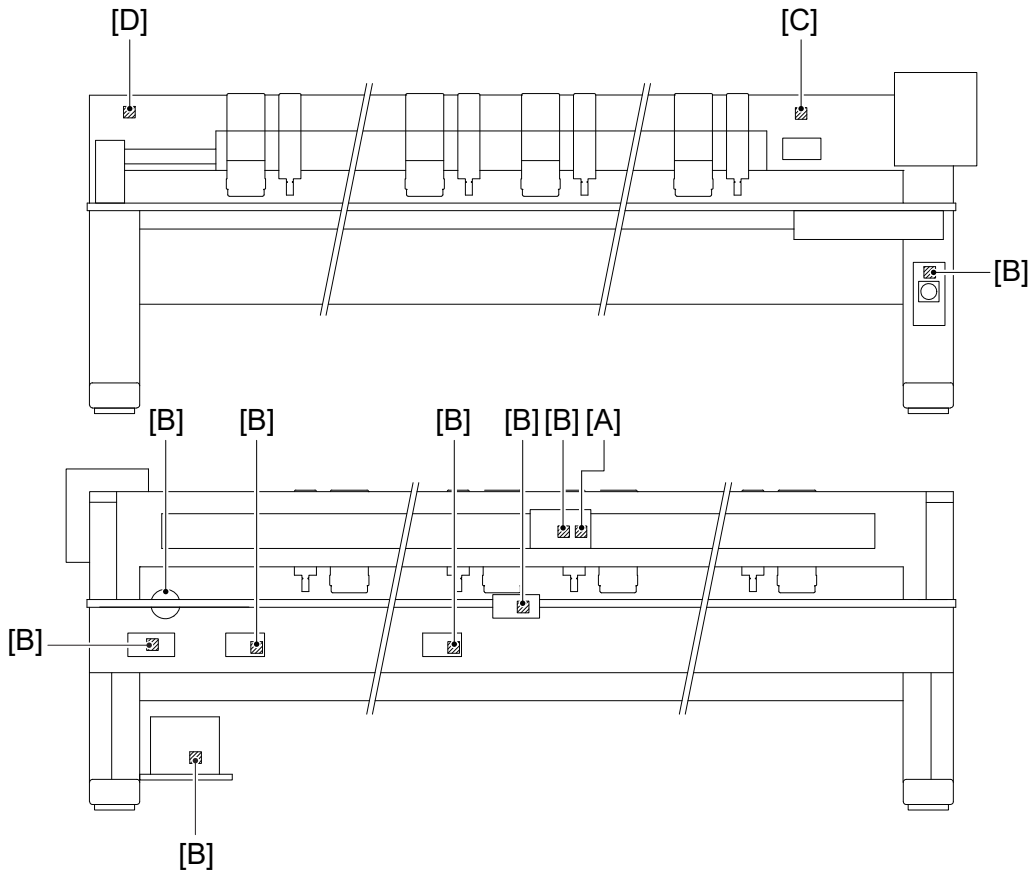

[A] Pay attention not to be caught into the machine.



There could be danger of being caught or clipped. Persons except the service personnel designated by Tajima should not open the covers.

[B] Pay attention to high voltage.



There could be danger of electric shock, burning, or death. Persons except the service personnel designated by Tajima should not open the covers. When opening the covers, wait for four minutes after turning off the power switch.

[C] Pay attention around needle.

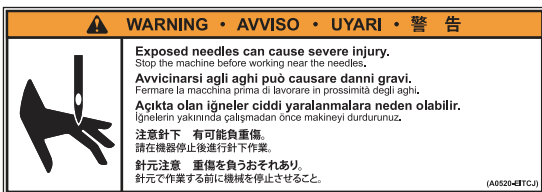

[D] Pay attention not to be caught into the machine.

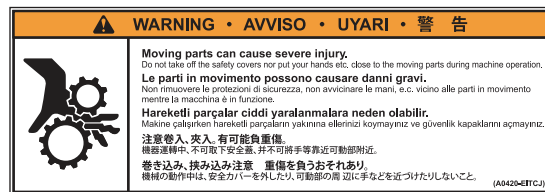



MUST DO LIST AT MACHINE INSTALLATION

MODEL:	M/NO.:
	DATE / / / PIC:

Check the following items in order after “Chapter 7 Level adjusting”.

Chapter 8 Adjustment	Remarks	✓
1. Needle locating position	[FM head] Check and adjust the needle locating position. <ul style="list-style-type: none"> • The 1st needle on all heads • The last needle on all heads Equalize it at the 1st needle and the last needle. [LM head] Check and adjust the needle locating position.	✓
2. Lower dead point	Check and adjust the lower dead point.	✓
3. Upper dead point	Check and adjust the upper dead point.	✓
4. N-Pipe Lower Dead Point	Check and adjust the N-pipe lower dead point.	✓
5. Bevel gear	Check and adjust bevel gears gap in front/rear, left/right direction.	✓
6. Needle and rotary hook	Check and adjust the needle and the rotary hook timing and the gap.	✓

Chapter 9 Idling and test sewing	Remarks	✓
1. Lubrication	Lubricate to the rotary hook and the inside of the arm.	✓
2. Idling, jump	Run the machine at least 20 minutes without threads for all needles to remove anti-rust liquid from the rotary hook.	✓
	Check if the reciprocator catches the needle bar stud at inching.	✓
	Check if the jump device operates properly.	✓
3. Threading	Pass thread correctly.	✓
4. Test sewing	Check if the thread breakage or the needle breakage occurs.	✓

Table of contents

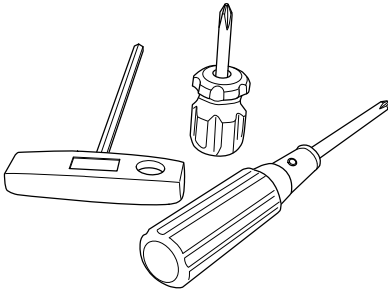

Chapter 1 Carrying	1
1. Installation environment	1
2. How to carry	2
Chapter 2 Installation	4
1. Vibration-preventive base	4
2. Anti-vibration stand	4
Chapter 3 Detaching of stopper	8
Chapter 4 Attaching	9
1. Thread course	9
2. Sequin device type III lower unit (option)	9
3. Front table and bar switch (option)	10
4. X drive system (Y-emb. space 1200 mm or more)	11
5. Table support (Y-emb. space 750 mm or more)	12
6. Attaching of border frame	13
7. Operation panel stand (Y-emb. space 850 mm or more)	14
8. Operation panel	15
9. Beam sensor (option)	17
10. Laser line marker (option)	18
11. Take-up lever adjuster	18
Chapter 5 Connection of power cord	19
1. Important safety instructions	19
2. Power cord and no fuse breaker	20
Chapter 6 Operation panel settings	21
1. Parameter setting	21
2. Frame Origin Memory	22
Chapter 7 Level adjusting	23
1. Level adjusting	23
2. Center support	25

Table of contents

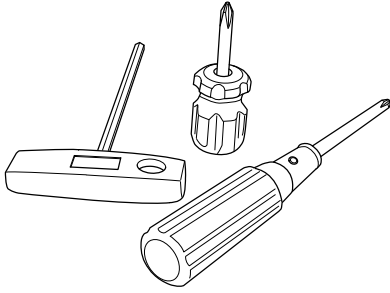

Chapter 8 Adjustment 33

1. Needle locating position 33
2. Lower dead point 34
3. Upper dead point 36
4. N-Pipe Lower Dead Point 37
5. Bevel gear 38
6. Needle and rotary hook 38

Chapter 9 Idling and test sewing 39

1. Lubrication 39
2. Idling, jump 41
3. Threading 41
4. Test sewing 46

Chapter 1 Carrying

1. Installation environment

CAUTION

- ! Install the machine on a sturdy floor.

The floor structure must be strong enough to bear the machine weight (indicated on the spec. plate). If the floor is supported by steel frames, place the machine stand on the steel beams as long as possible.

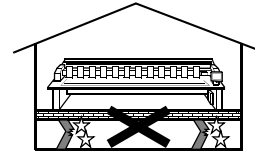

- ! Prevent the operation noise in the environment.

This machine is designed to reduce noise during operation. To improve the sound insulation performance in a factory still more, use the interior finish materials which show high sound insulating performance for the walls, ceiling, and floor of the factory.

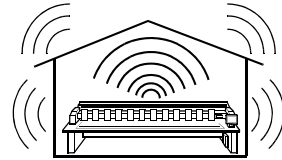

- ⊘ Avoid direct sunlight.

If the machine is exposed to direct sunlight over an extended period of time, the machine body may be discolored or deformed. Put curtains or shades to the site to prevent the machine from direct sunlight.

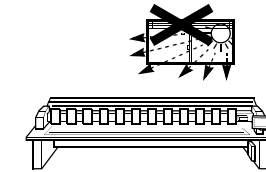

- ! Provide enough space for maintenance.

Taking account of workability when maintaining and inspecting the machine, provide 50 cm or more working area to right, left and rear directions of the machine against obstacles such as walls.

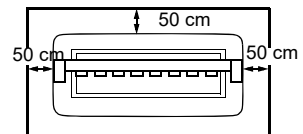

- ! Avoid dust and moisture.

Since dust and moisture lead to dirt and rust on the machine, use the machine in an environment of facility of air conditioner, and clean the working place periodically. Use caution not to expose the machine to direct wind from the air conditioner so that embroidery threads do not become disheveled.

Degree of pollution: 2 or less

Humidity: 30 to 95%RH (relative humidity) without condensation

Ambient temperature: 5 to 40° C (during operation), -10 to 60° C (during storage)

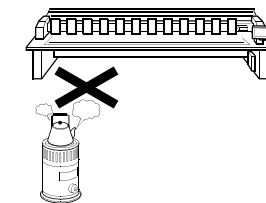

- ! Pay attention to interference of radio wave.

Although the machine is designed not to apply radio wave to other equipment, there could be cases where it causes interference depending on operation environment and type of equipment. If such problems arise, install the equipment as apart from the machine as possible.

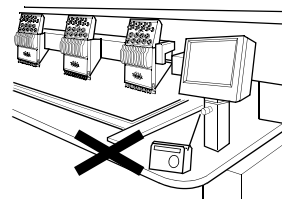

- ! Pay attention to power supply style.

When supplying the power, meet the following condition.

- Excess voltage category: III

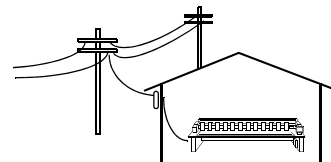

2. How to carry

2-1. When using a crane

! DANGER

! When lifting (suspending) the machine, make sure that there is no person standing in the danger area around the machine, especially under the machine.

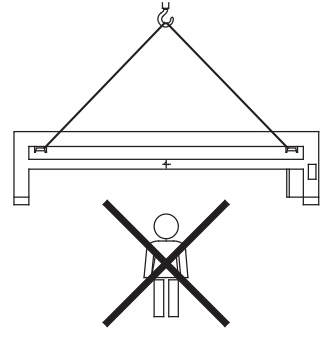

! WARNING

! When lifting the machine, attach the anti-come-off bolts so that the nylon slings do not come off.

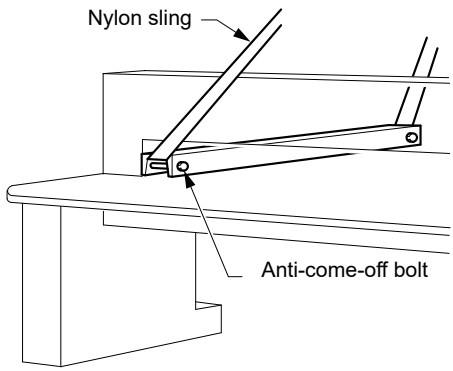

! When lifting the machine, use a nylon sling that is long enough to provide a sling angle of 50° or more so that the nylon slings do not come off.

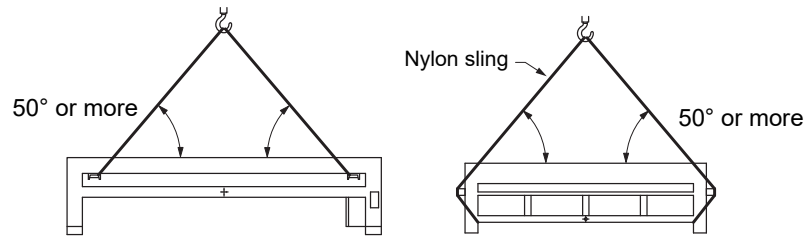

2-2. When using a forklift

WARNING

- ! When you use a forklift, pay enough attention not to drop the machine. Move the forklift to lift the machine with reference to the "gravity mark" that shows right and left balance of the machine.

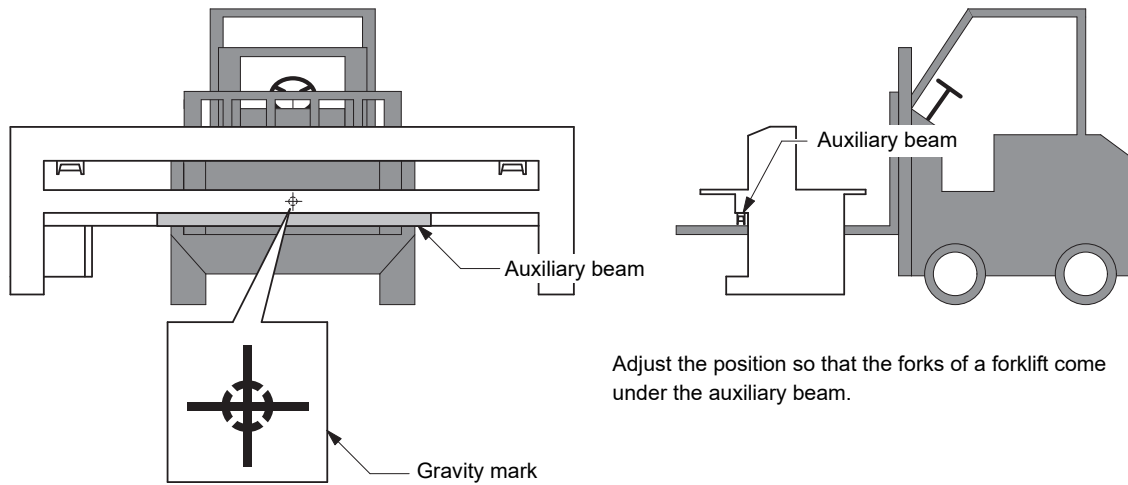

Chapter 2 Installation

! WARNING

! Workers should understand the procedure thoroughly, and then start working. Unexpected action could cause injury.

1. Vibration-preventive base

This work is supported only for the machine in which vibration-preventive bases are packed.

- (1) Put the square lumbers 1 of about 3 cm thick and vibration-preventive bases 2 on the installation site, and put the machine once on them.
- (2) Set the hexagon bolt 3 and the nut 4 to the stand and screw in the hexagon bolt 3 until the machine is lifted.
- (3) Remove the square lumber 1.

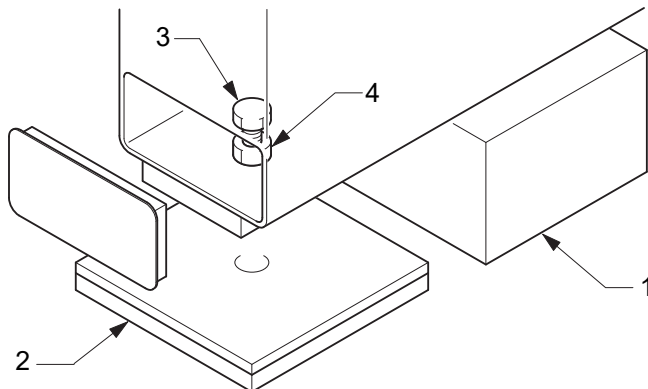

2. Anti-vibration stand

! CAUTION

! There are two types of anti-vibration stand, one is for the front side and another is for the rear side. Therefore, do not mistake. Some problem like a thread breakage could occur.

This work is supported only for the machine in which anti-vibration stands are packed.

Attaching position becomes opposite back and forth according to Y-axis (lengthwise) embroidery space. Attach the anti-vibration stand to the correct position referring to the below chart.

Y-axis emb. space 679 mm or less	Y-axis emb. space 680 mm or more
Front: BU-1000TMA Back: BU-1250TMA	Front: BU-1250TMA Back: BU-1000TMA
or	or
Front: BU-1250TMA Back: BU-2000TMA	Front: BU-2000TMA Back: BU-1250TMA

Chapter 2 Installation

There are following two types (Type A and Type B) of anti-vibration stand. Adjusting methods are different each other. Therefore, perform working after checking the anti-vibration stand packed in the machine.

Type A

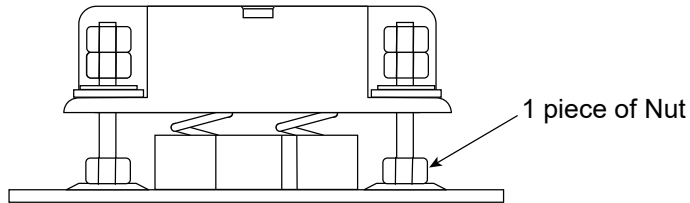

Type B

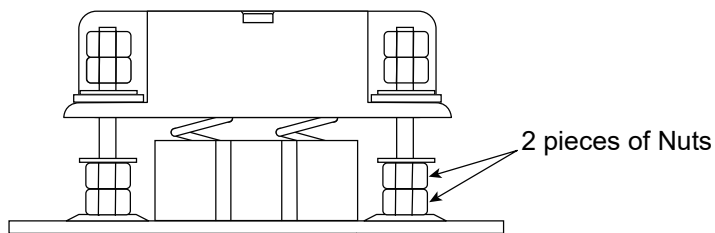

[How to adjust Type A]

- (1) Make the tip of the adjusting bolt 1 come out 15 mm from the bottom of the stand and set the anti-vibration stand 3 to the position where the adjusting bolt 1 enters to the hole 2 for the anti-vibration stand bolt. Adjust the position again to push the resin bushing 5 along the stopper bolt 4 into the anti-vibration stand 3. After that, set the nut 6 and tighten the nut of the adjusting bolt 1.

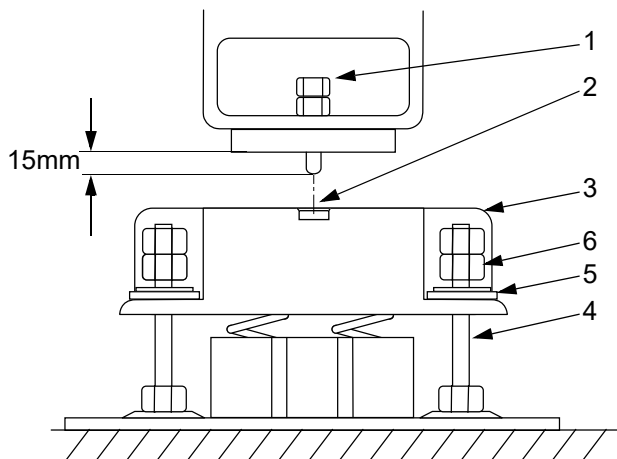

Chapter 2 Installation

- (2) Adjust the position of the nut so that the clearance between the nut and the washer (the clearance between the washer and the anti-vibration stand) becomes 1 mm.

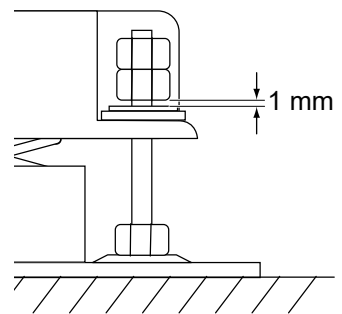



- (3) Tighten each nut temporarily until the last leveling.

[How to adjust Type B]

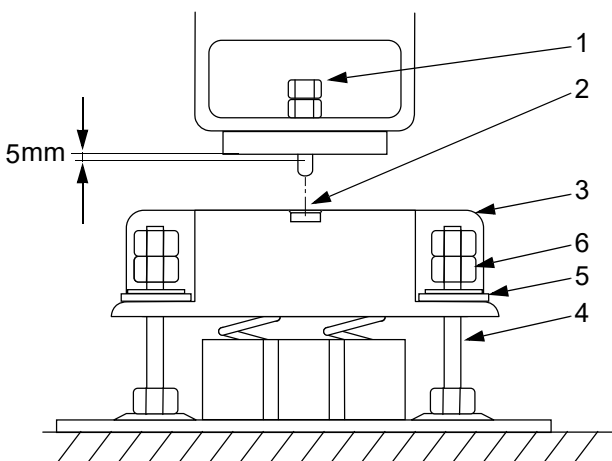
- (1) Make the tip of the adjusting bolt 1 come out from the bottom of the stand by about 5 mm and set the anti-vibration stand 3 to the position where the adjusting bolt 1 enters to the hole 2 for anti-vibration stand bolt. Perform adjustment again so that it becomes possible to push the resin bushing 5 along the stopper bolt 4 into the anti-vibration stand 3. After that, set the nut 6 and tighten the nut of the adjusting bolt 1.



 For details of adjustment, please consult the distributor.

 Installation condition



- (2) Adjust the position of nut so that a clearance between the nut and spacer (a clearance between the spacer and vibration-preventive base) becomes 1 mm.

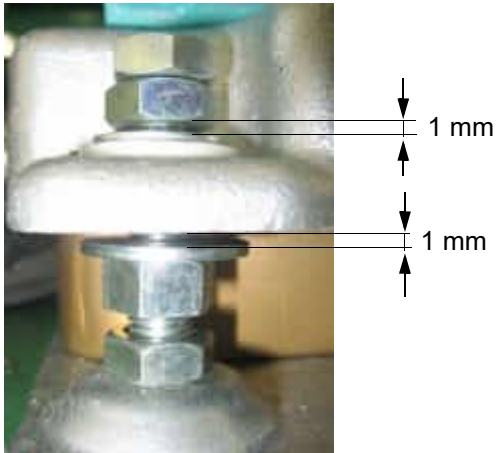

- (3) Tighten each nut temporarily until the last level adjustment is finished.



For details of adjustment, please ask the distributor for information.

Chapter 3 Detaching of stopper

- (1) Attaching position of stopper B differs depending on model. Detach all the covers at the beginning and check the attaching position of the stopper.

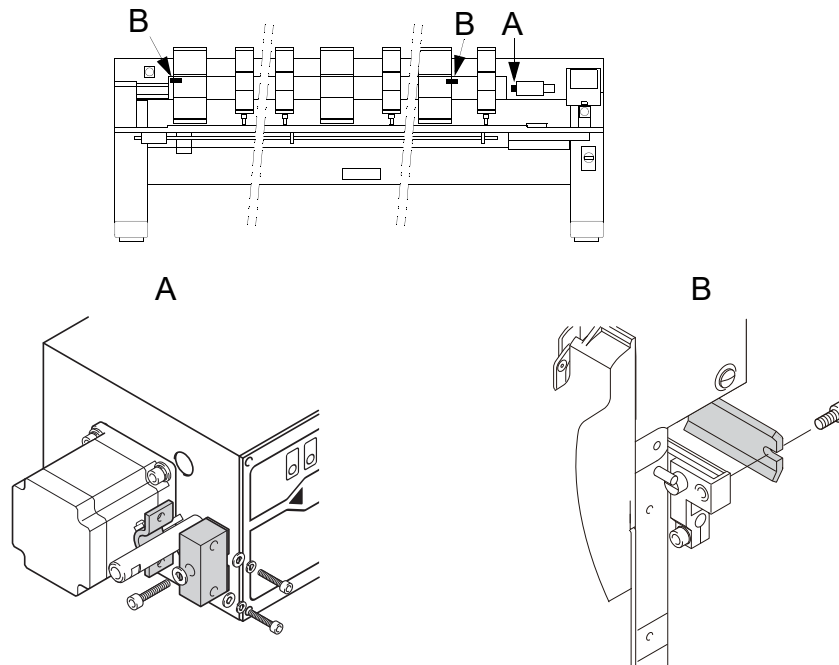

- (2) Before using the machine, detach stoppers A and B.
 • An example of attaching position of stopper B in 20-head machine: 1R, 20L
 (1R stands for right side of the first head.)

Chapter 4 Attaching

1. Thread course

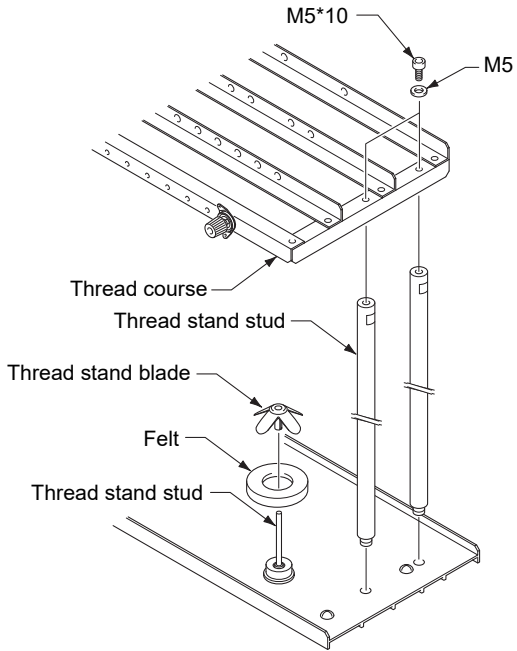

2. Sequin device type III lower unit (option)

Attach the lower unit that is packed separately with the machine as shown in the illustration below.

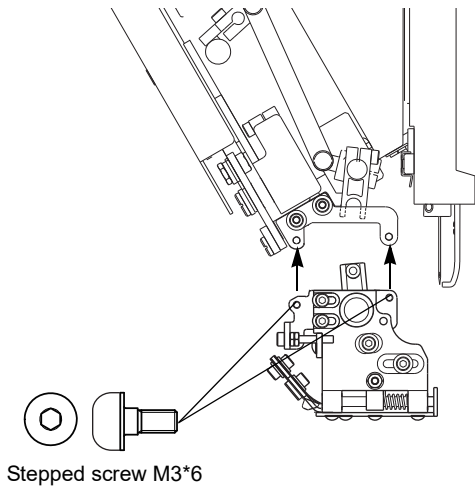

When attached



Regarding how to adjust etc., refer to the separate user's manual.

3. Front table and bar switch (option)

Attach the front table of table cut C-2, 3, 4, 5, 8 or 9.

- (1) Attach the front table that is packed with the machine.

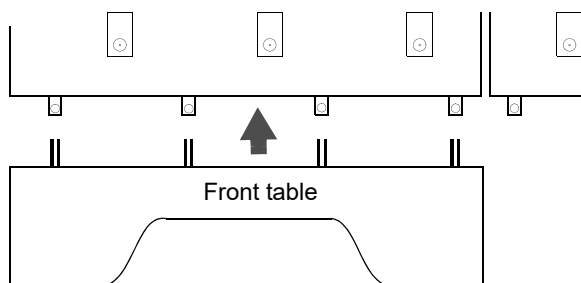

- (2) Tighten the table aligning plate by using the hexagon socket head cap screw.



- (3) Fix the table holder from the side by using the button screw and tighten the wood screw from the back.



- (4) Attach the bar switch by using the wood screw.



Attach the front table so that there is no gap between the aligning faces of the table.



Use the hole for wood screw at the back side of the front table.



Use the hole for wood screw at the back side of the front table as the attaching position.

4. X drive system (Y-emb. space 1200 mm or more)

Attach the X drive system that is packed separately to the machine.

- (1)** Put the coupling 2 through the shaft 1. Then, attach the X drive system 4 so that there is no gap at the stand connecting section 3 and fix it by using the screws 5.

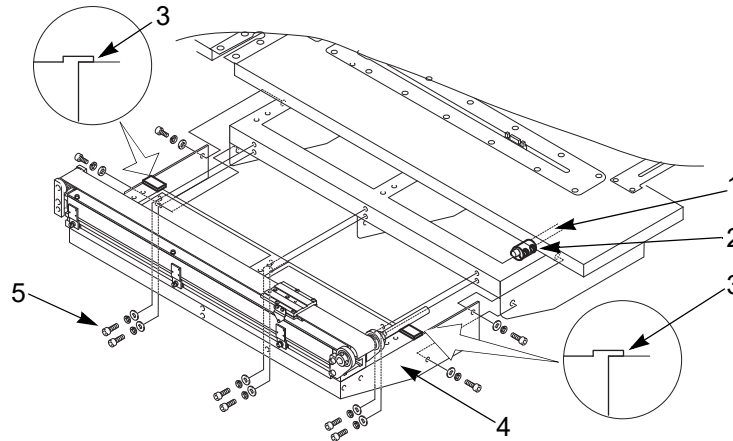

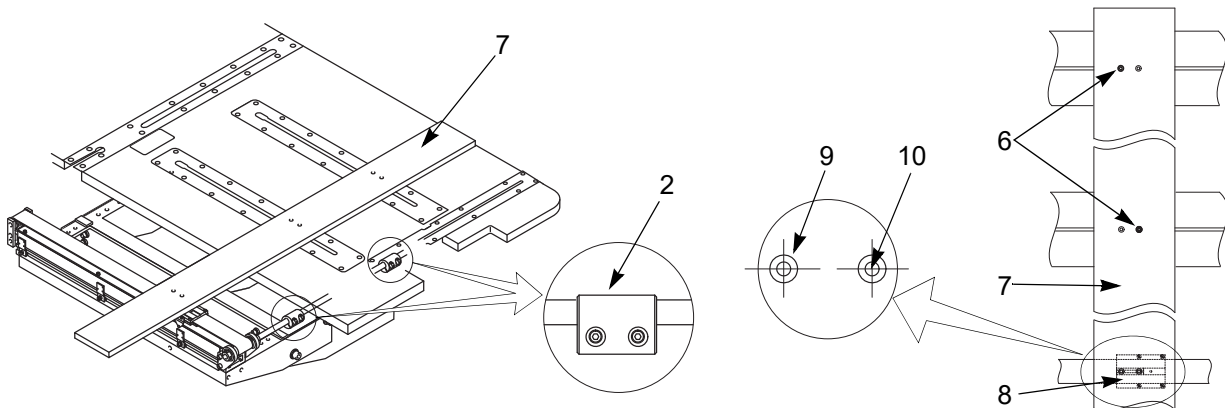

- (2)** Tighten the screws 6 at two spots to fix the XZ sash 7 temporarily. After that, move the feed plate 8 to align the attaching hole 9 of the XZ sash 7 with the center of screw hole 10 of the feed plate. Then, tighten the coupling 2.

 Line up all the couplings 2 and tighten them.



- (3)** Detach the XZ sash 7 once. Attach the table 11, and fix it by using the screw 12.

 Check again if the attaching hole 9 is aligned with the center of screw hole 10 of the feed plate.

 Check if the Z spacer 13 does not touch the table cover groove 14 and both the gap and step of the table connecting section 15 are 0.5 mm or less.

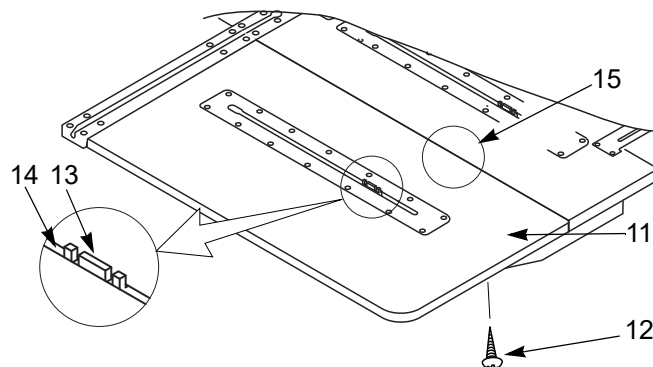

- (4)** Attach the XZ sash 7 again, and fix it by using all the screws 6.

 Attach the XZ sash 7 so that it and the border frame become parallel (=> p.13).

5. Table support (Y-emb. space 750 mm or more)

Fix the table support (packed with the machine) under the table. Screw holes or nuts are embedded under the table at fixing spots (Fixing spots differ depending on spec. of the machine).

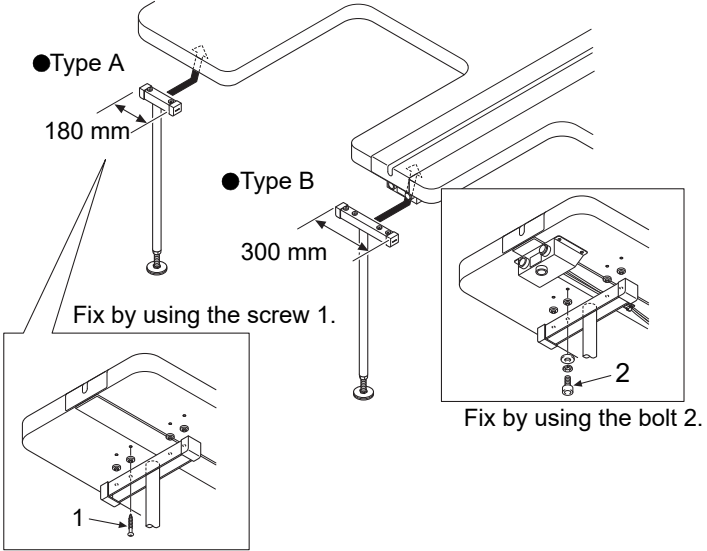

An example of fixing spot

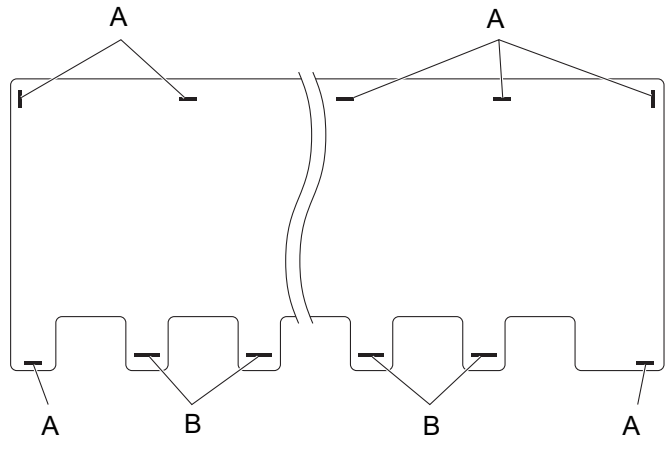

Fixing nut (for type B)



Put the table support on the floor, adjust the height by the adjusting bolt 3, and fix by the bolt 4 (the same manner in types A and B).

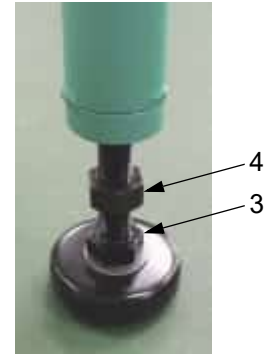

6. Attaching of border frame

The target models are the machines with table cut type C3, C4, C5 or C9 specified (but the front table is detached at shipment in the factory).

- (1) Make a clearance 3 of about 1 mm between the border frame 1 and XZ-sash 2.
- (2) Fix the border frame 1 by using attaching screws 4.

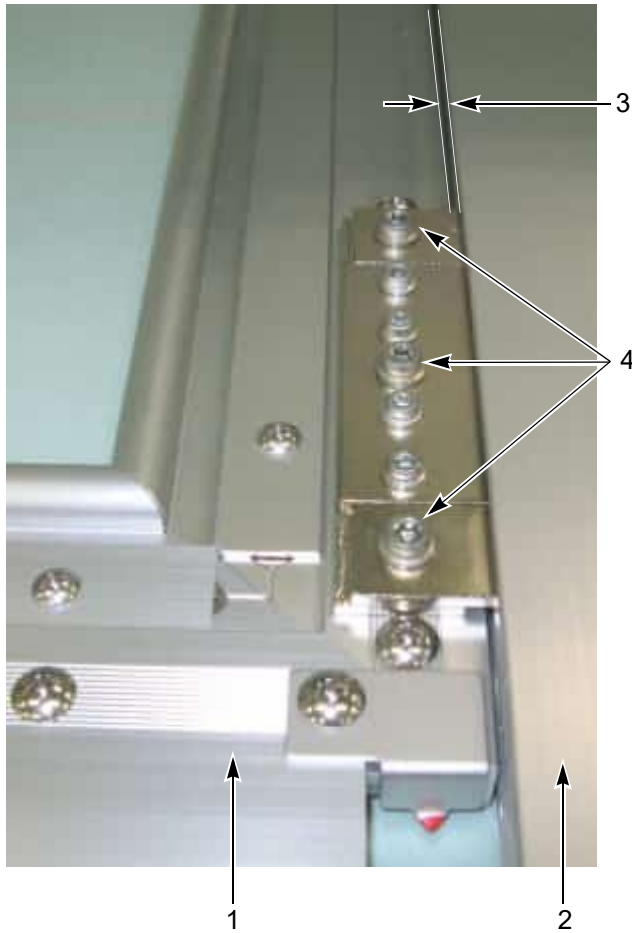

7. Operation panel stand (Y-emb. space 850 mm or more)

- (1) Pass the controller pipe 1 from the top of the table.
- (2) Attach the pipe stand 2 by using the accessory screw 3.
- (3) Pass all the harnesses 4 (for the emergency stop switch and the operation panel) to the controller pipe 1.
- (4) Connect the harness for the emergency stop switch to the emergency stop switch 5 and attach the switch to the controller pipe 1.
- (5) Attach the operation panel 6 to the controller pipe 1, and connect the harness for the operation panel (=> p.15).
- (6) Perform adjustment by using the screw 7 so that a clearance between the controller pipe 1 and pipe passing hole 8 becomes even.

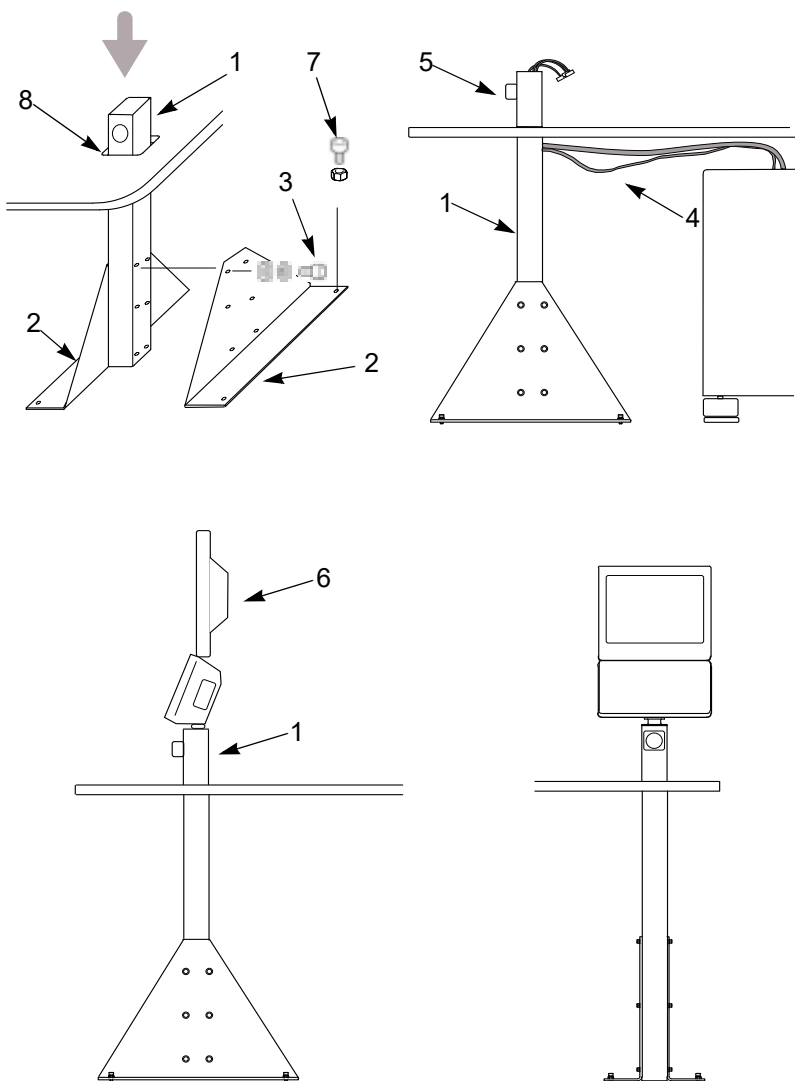

Pass harnesses from the passing hole positioned at the back of the controller pipe.



8. Operation panel

8-1. 6.5-inch type

Attach the operation panel to the controller pipe, and connect four connectors (photo below).

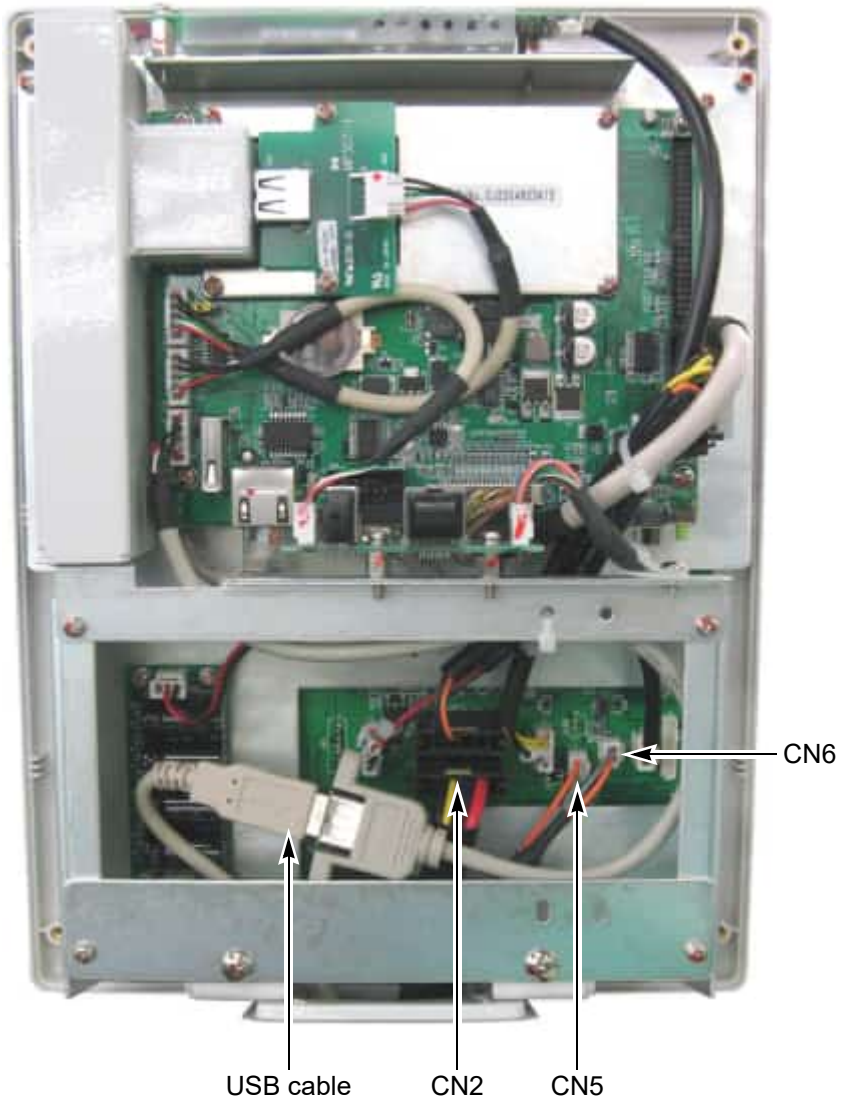

8-2. 17-inch type

Attach the operation panel to the controller pipe, and connect six connectors (figure below).

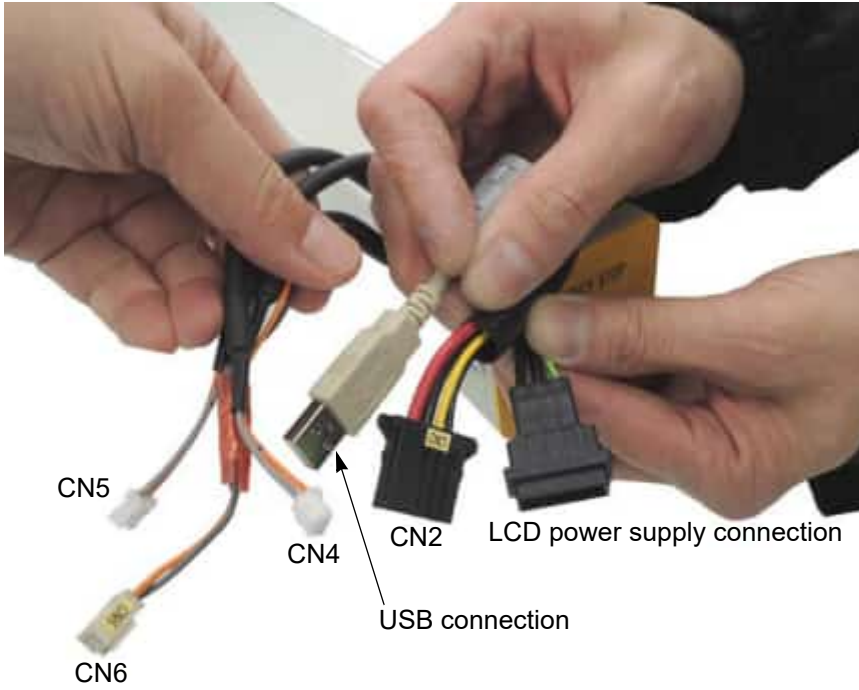

 Connection to the switch card.
CN2, CN5, CN6

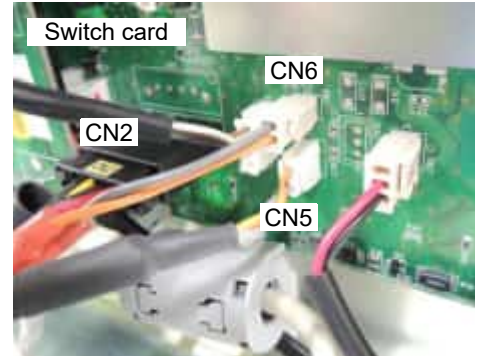

CN4

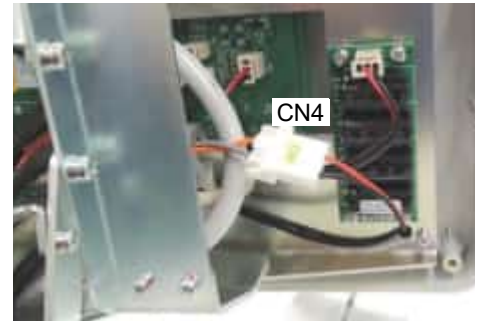

 USB connection
Connect to the USB port of the CPU card.

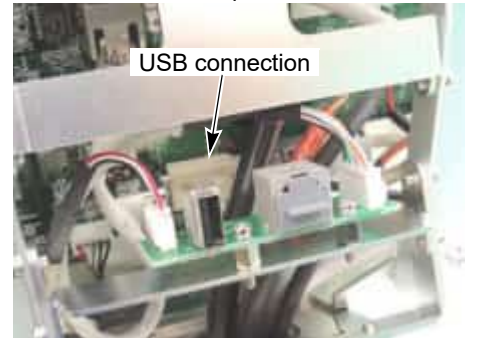

 LCD power supply connection



9. Beam sensor (option)

9-1. Multi head machine

In case of machine with Y-emb. space 750 mm or more and equipped with sequin device, attach the beam sensor away from the stand by 350 mm as shown in the photo below. Attach also the reflector to the opposite side of the table by the same length.

Attaching position of beam sensor

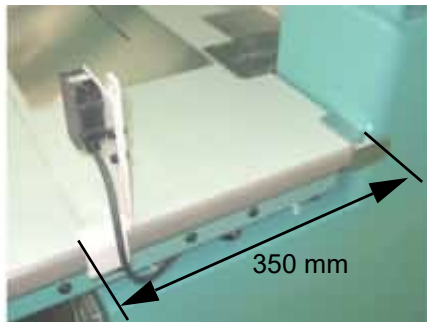

9-2. Machine with smaller number of heads

Attach the beam sensor and reflector to the position as shown in the illustration below.

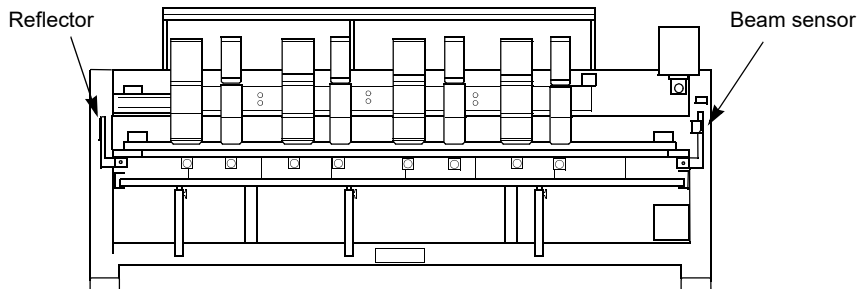

For details, refer to the separate user's manual.

10. Laser line marker (option)

DANGER

This device uses red semiconductor laser of class 3a.

- Maximum output: 2.5 mW
- Diode laser wave length: 635 nm

 Visible laser beam is emitted from the aperture while this device is working. Since both beam and scattered light are dangerous, do not see and touch these directly.

Attach the push button switch box to the back side of the table, attach the laser line marker to the stand, and connect the connector. To adjust light axis, loosen the screw.

Laser line marker



Push button switch box

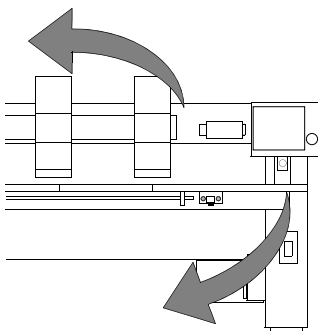

11. Take-up lever adjuster

To strengthen thread tension more, attach the take-up lever adjuster using 2 pieces of screws. Regarding how to pass thread and how to adjust, refer to the chapter 9 (=> p.45).

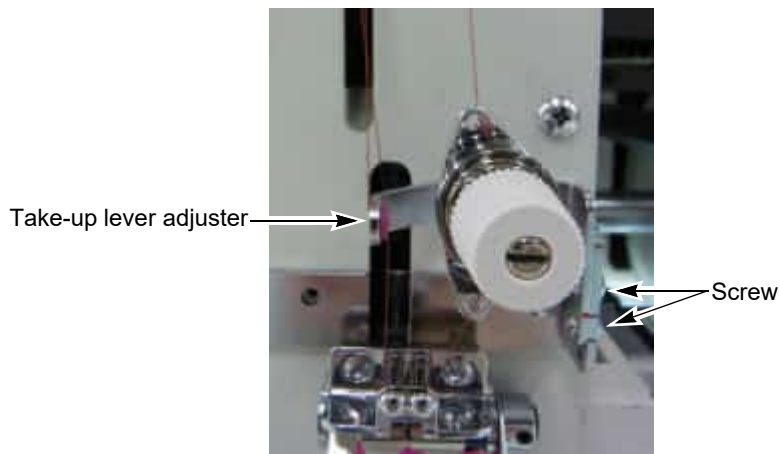



Chapter 5 Connection of power cord

1. Important safety instructions



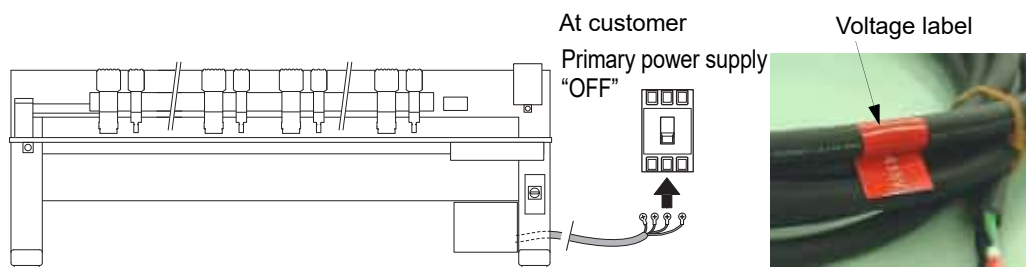



DANGER

-  When you connect the power cord, be sure to turn "OFF" the primary power supply. There could be a danger of electric shock, burning or death. In addition, check if the voltage of the voltage indicating label that is attached to the power cord fits to voltage spec. on your side, and then connect the power cord to the primary power supply.



-  If the machine needs to be connected to an external power supply, the power supply cable connection must be done only by the service personnel assigned and trained by TAJIMA or qualified technician.

WARNING

-  When supplying the power, conform to excess voltage category "III".
-  Connect the machine to the power supply line that is not connected to machines subject to large load fluctuation such as elevators and presses so that the machine can operate in stable conditions.
-  Check the power supply voltage for operation of the machine by using a multimeter.
Voltage: Within +/-10% of the rated voltage
-  The power supply cable must be laid out of the operator's moving area so that the operator does not step on the cable.
-  Insert the power cable plug fully. If a metallic part touches a blade in the plug, it may cause fire and/or electric shock.
-  Since there is the danger of electric shock due to leak current, be sure to connect the grounding wire. In addition, degree of grounding should be type D or higher (grounding resistance 100 ohms or less).

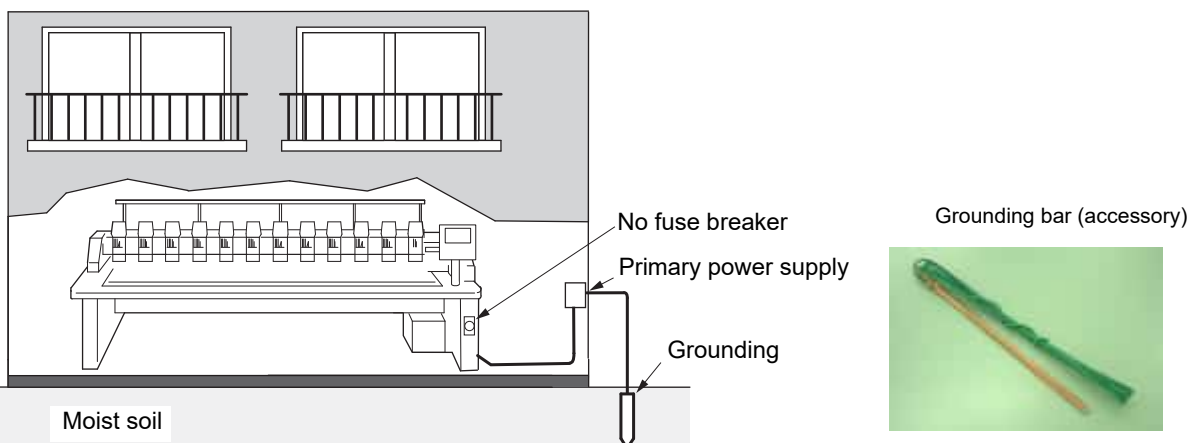

! CAUTION

- ! In addition to full-time leak current, leak electric current generated by harmonics and surge flows in the power cable of the machine. For this reason, if selection and installation of breaker of leak current and leak current relay used for the factory are not correct, malfunctioning of the machine may occur. Regarding connection of power cord, observe the following items.
- ! Use a breaker of electric current leakage and leak current relay for which measures are taken against harmonics and surge. If such a breaker and a relay are not available, select conventional breaker and relay with sufficient leak current capacity to absorb leak current caused by harmonics and surge. (In this case, constant leak current must be controlled satisfactorily.)
- ! Regarding capacity of electric current leakage for breaker of electric current leakage and leak current relay per machine, please consult your local TAJIMA distributor.
- ! For actual product names of breaker of electric current leakage and leak current relay for which measures are taken against harmonics and surge, please consult your local TAJIMA distributor or electric engineers.
- ! To prevent the machine from property damages, one embroidery machine should be connected to one no fuse breaker. Property damages include a drop of output of the main shaft motor, etc., stop position error and color change error caused by the stop position error, design displacement, etc.
- ⊘ Do not pass the power cord to the electric wire passing holes.

2. Power cord and no fuse breaker

- (1) The voltage indicating label that fits to spec. of the machine is attached to the power cord.

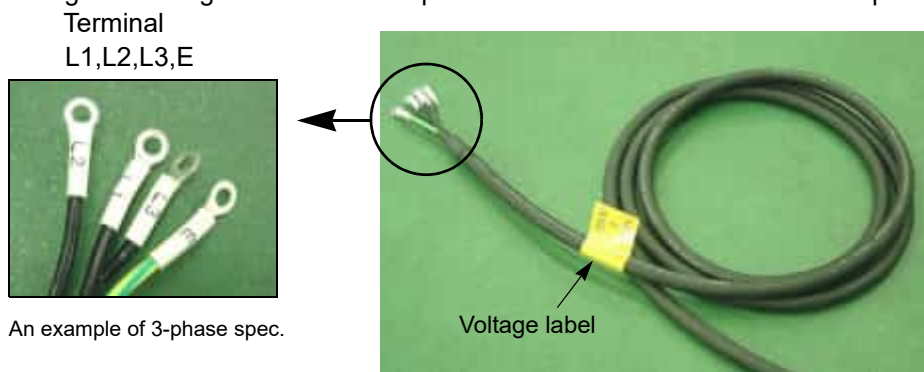

- (2) Sealing plate (Multi-head machine only)

When you detach the switch cover 1, you will find the "Sealing plates 2" attached at the lower section of the breaker. Since these plates may be necessary depending on area where you use the machine (subject to EN spec.) in view of safety standard, keep these plates as they are.

 In setting up the machine, it is not necessary to detach the switch cover 1.

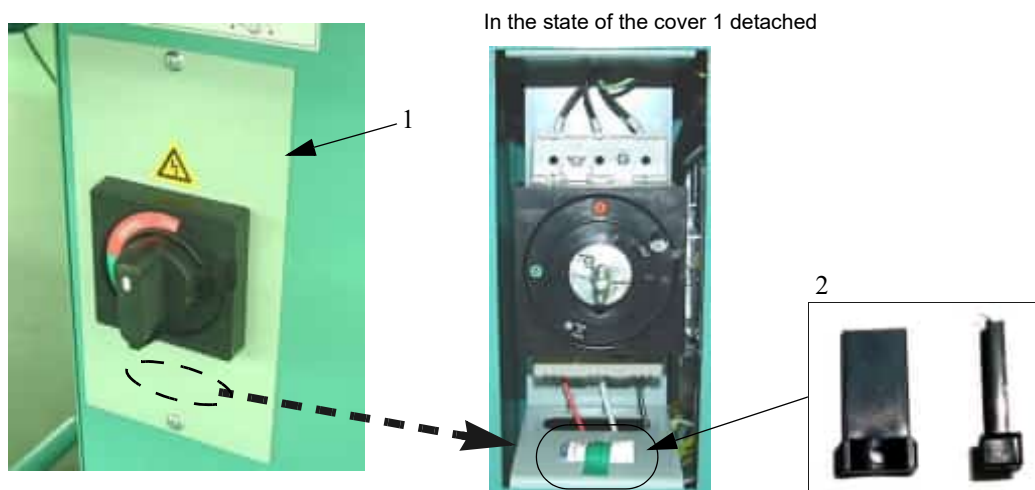

Chapter 6 Operation panel settings

1. Parameter setting

A parameter list is attached to the back of the operation panel. Check setting values. At this moment, check also version of the software.



"Parameter setting chart" at shipment from the factory is attached.



Regarding how to set parameter, refer to the separate user's manual.



Regarding information about the latest version of software and how to obtain the software, please ask the distributor.

2. Frame Origin Memory

2-1. Checking of embroidery space

Move the embroidery frame by manual frame travel in X-axis (right and left) direction and Y-axis (back and forth) direction with the power switch turned "ON". Check if the embroidery space indicator 1 stops on the mark-off line 2.

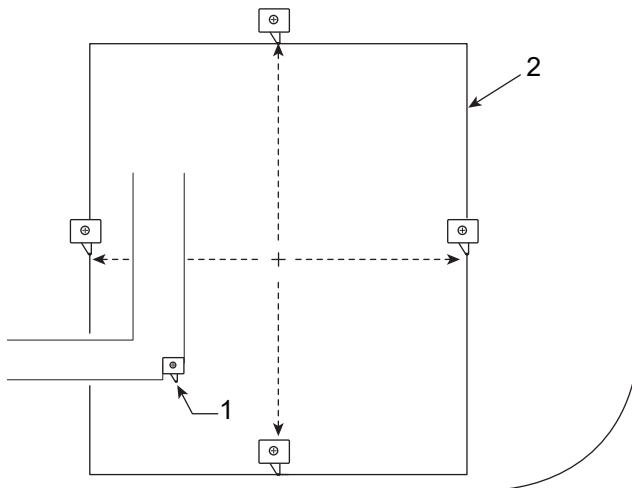

2-2. Execution of frame origin memory

Make this machine memorize the frame origin. Perform this operation in the following conditions.

- In case of setup of this machine
- In case of installation of software
- There is a possibility that the embroidery frame was moved with the power turned OFF in changing of frame.

CAUTION

 When performing this operation, do not put your hands, etc. on the machine table. You could be injured by moving frame.

Position of frame origin

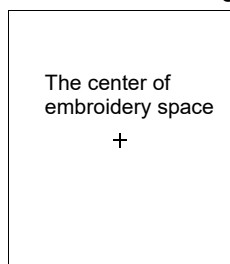

Some machines equipped with optional device such as sequin device may be set to stop short of the embroidery space indicating mark-off line.



Perform adjustment by using the limit sensor.



Regarding how to execute frame origin memory, refer to the separate user's manual.



Frame origin is an anchoring point that calculates the current frame position. If the calculation is wrong, the following troubles will occur.

1. Frame coordinates are not displayed correctly.
2. The frame does not return to the interrupted position even after performing power resume operation.

Chapter 7 Level adjusting

1. Level adjusting

(1) Adjust level by using a level gauge in the state of no slant or con-
tortion of the machine. There are four spots for measuring.

Leveling in back and forth direction

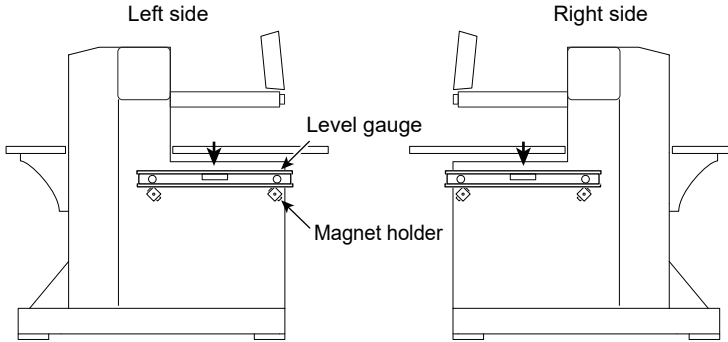

Leveling in right and left direction

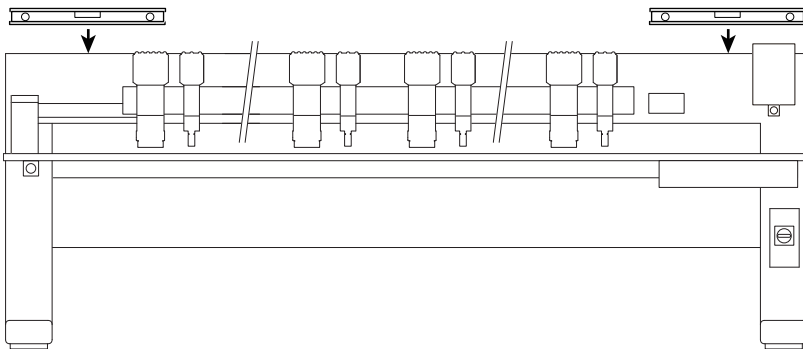

(2) Adjust a position so that a corner of the magnet holder 1 comes to the center of the punching mark 2.

(3) Put the level gauge 3 on the magnet holder 1.

Degree of level: within $\pm 0.5^\circ$

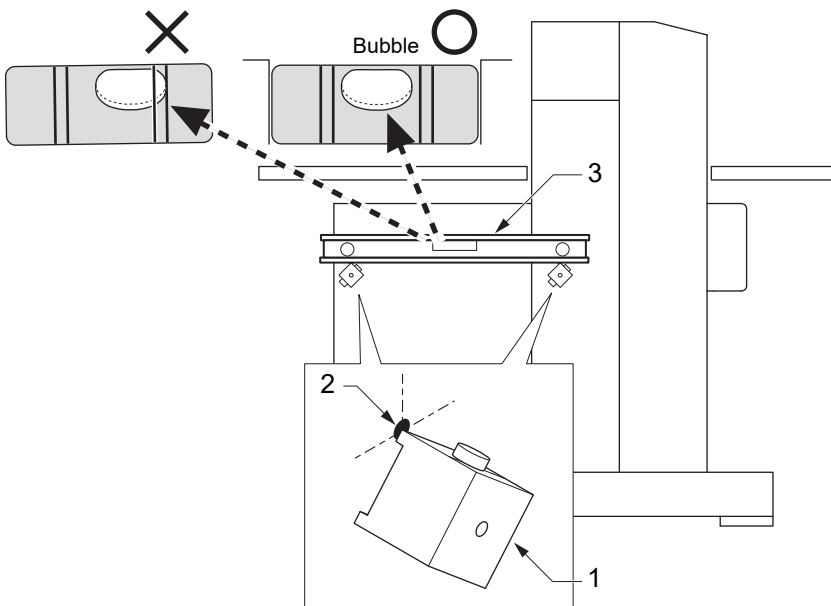

Perform adjustment after attaching cut table, option etc.



The distributor prepares the level gauge 1 and magnet holder 2. Use the level gauge 1 with its length 60 cm or more and its sensitivity of within 0.5 m/m.



Use two pieces.



Punched mark 2

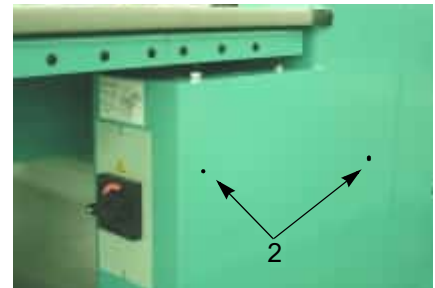

If a bubble is set within the range (inner lines) of a level gauge with its sensitivity of 0.5 m/m, the degree of level becomes " $\pm 0.5^\circ$ ".

Chapter 7 Level adjusting

(4) Adjustment

a. Vibration-preventive base

Adjust two pieces of hexagon bolt 4 that are on a diagonal line while checking a bubble of the level gauge, and then tighten the nut 6 after adjusting the remaining two hexagon bolts 5. At this time, perform adjustment so that effectiveness (load) of four pieces of hexagon bolt becomes equal.

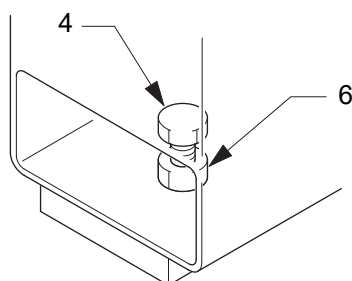
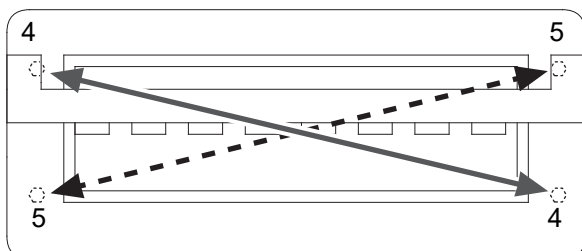

b. Anti-vibration stand

Lift the necessary spot of the machine by using a forklift according to the condition of the bubble of the level gauge and tighten or loosen the adjusting bolt according to the circumstances. After that, lower the machine and check the condition of the bubble. If you do not achieve good evenness, repeat the above works.



Adjusting bolt



Load may not be equally applied depending on model.



Do not tighten the adjusting bolt in the state of the machine not lifted. Bolt hole of the anti-vibration stand will be damaged.

2. Center support

2-1. Center support (TLMX-mixed type)

(1) Attaching

The center support and the vibration-preventive base or the support base are packed in M-spec. or larger machine. The center support sometimes may not be packed in some M-spec. or larger machine depending on the specification.

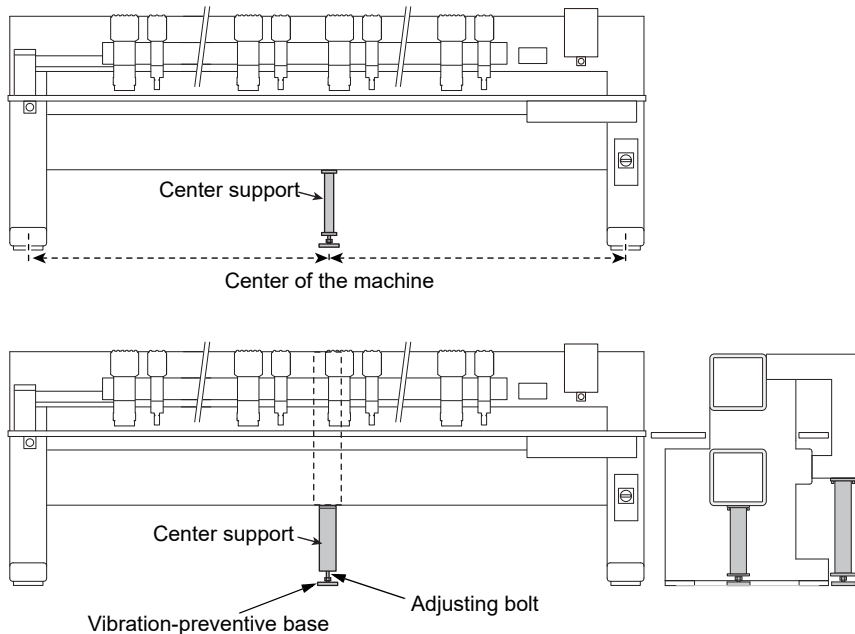

The following is a standard example of attaching the center support. In case of installing the anti-vibration stand additionally, the support base is packed in the machine instead of the vibration-preventive base.

- a.** M-spec. machine (5,346 to 5,845 mm), G-spec. machine (5,846 to 6,455 mm)

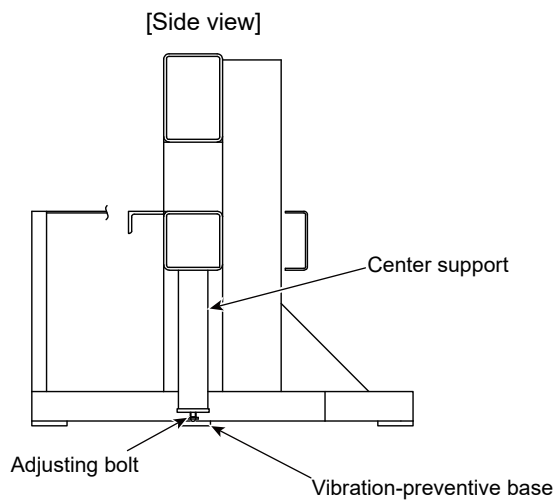

Center support



Vibration-preventive base



Support base



Do not tighten the adjusting bolt too strong.
For details, refer to p.27.

Chapter 7 Level adjusting

b. 7 meter machine (6,456 to 7,455 mm)

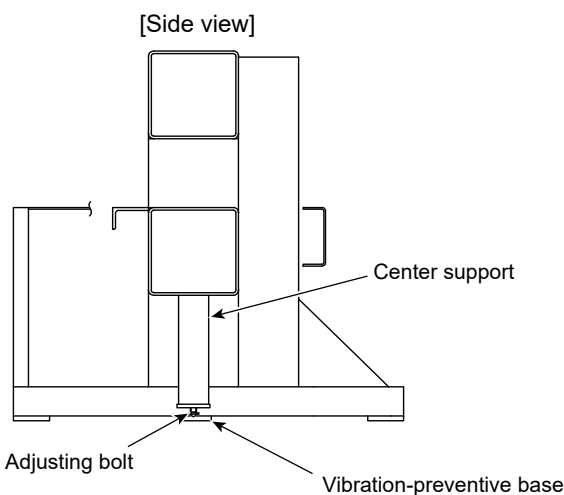

c. 8 meter machine (7,456 to 8,355 mm) with Y-emb. space of less than 1200 mm

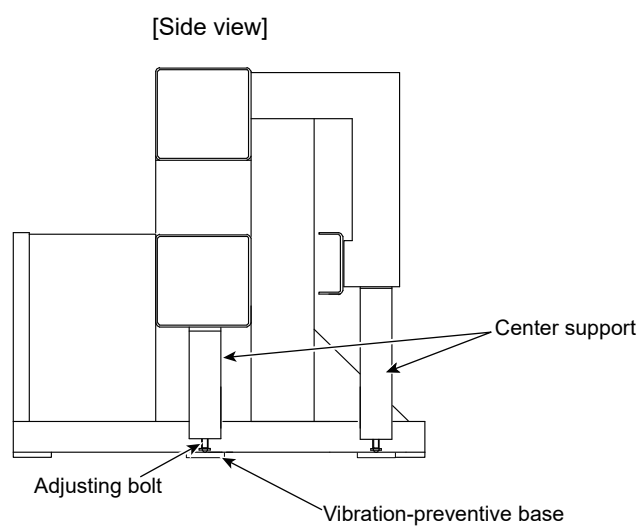

 Fix the center support by using the hexagon socket head cap screw.

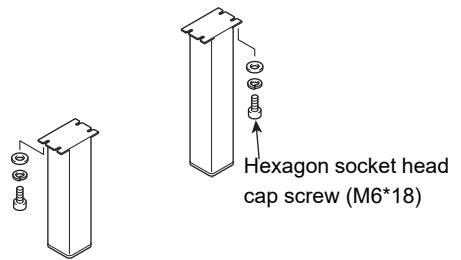

d. 8 meter machine (7,456 to 8,355 mm) with Y-emb. space of 1200 mm or larger, 8.5 meter machine (8,356 to 8,865 mm) with Y-emb. space of less than 1500 mm

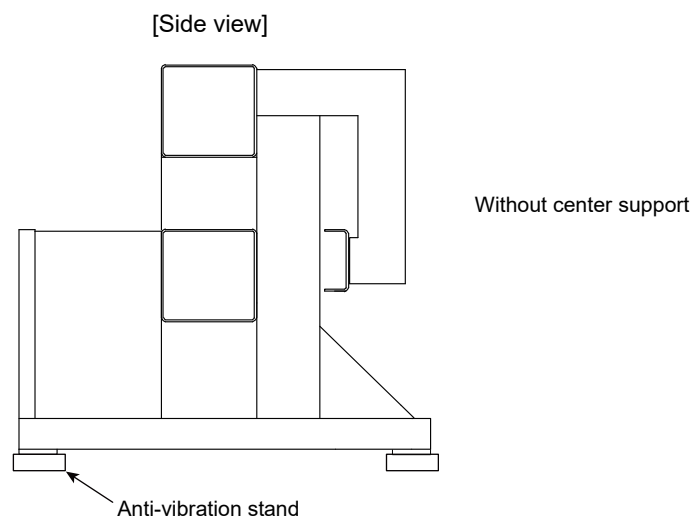

Chapter 7 Level adjusting

- e. 8.5 meter machine (8,356 to 8,865 mm) with Y-emb space of 1500 mm, 9 meter machine (8,866 to 9,500 mm), 10 meter machine (9,501 to 11,000 mm)

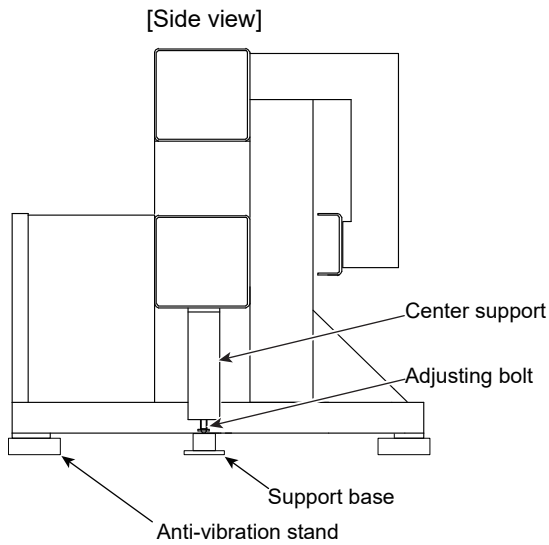

(2) Touching degree of adjusting bolt

CAUTION

-  Do not tighten the adjusting bolt too strong. Over-tightening could change the position of the lower dead point of the needle bar and the needle location, which could apply adverse affect to sewing.

Set the head of the adjusting bolt 1 in contact with the concave section 2 of the vibration-preventive base or the support base, then tighten the nut 3 after turning the adjusting bolt by 1/5 turn with a wrench.

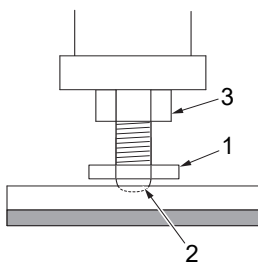

Fix the center support by using the hexagon socket head cap screw.

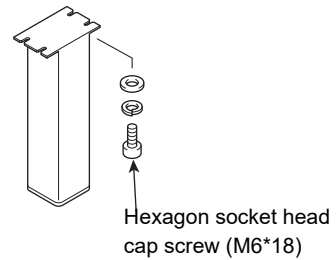

When vibration, noise etc. occur, adjust tightening degree of adjusting bolt.

2-2. Center support (TLMX-100, T00)

(1) Attaching

The center support and the vibration-preventive base or the support base are packed in G-spec. or larger machine. The center support sometimes may not be packed in some G-spec. or larger machine depending on the specification.

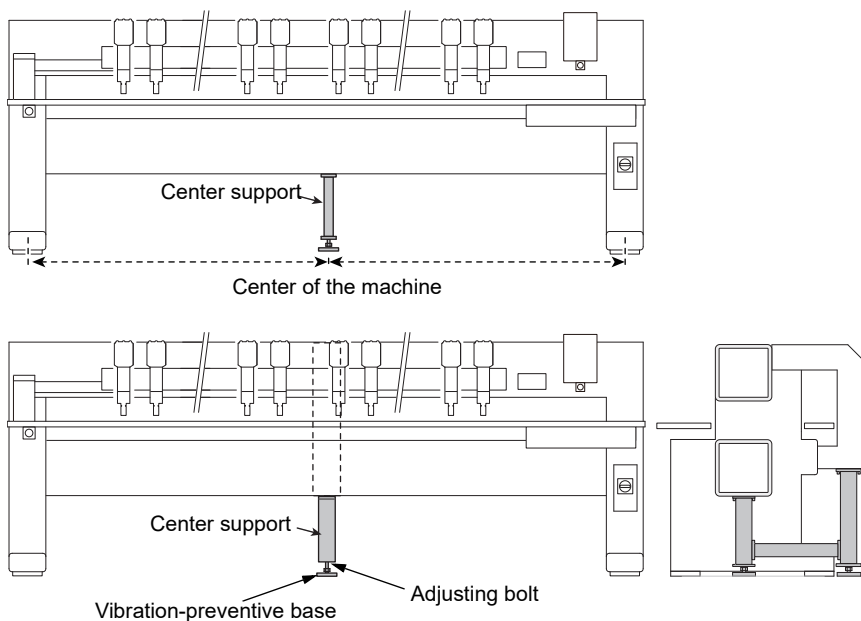

The following is a standard example of attaching the center support. In case of installing the anti-vibration stand additionally, the support base is packed in the machine instead of the vibration-preventive base.

a. G-spec. machine (5,636 to 6,455 mm)

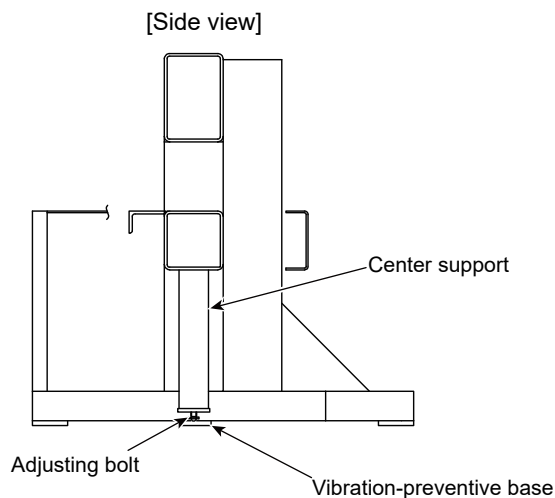

 Center support



 Vibration-preventive base



 Support base



 Do not tighten the adjusting bolt too strong.
For details, refer to p.32.

Chapter 7 Level adjusting

b. 7 meter machine (6,246 to 7,455 mm)

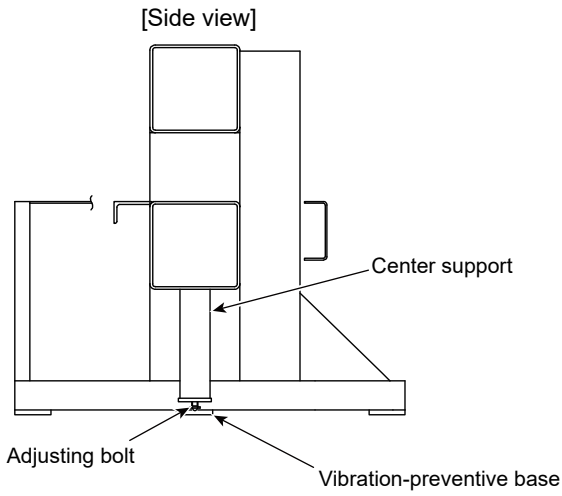

c. 8 meter machine (7,246 to 8,355 mm)
8.5 meter machine (8,146 to 8,865 mm) with Y-emb. space of less than 1200 mm

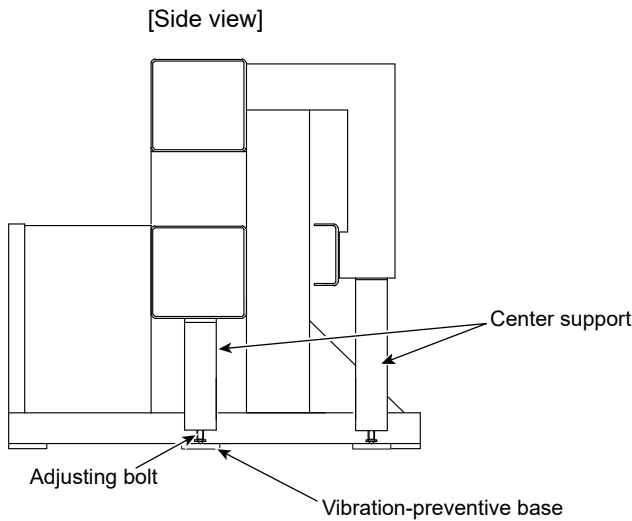

d. 8.5 meter machine (8,146 to 8,865 mm) with Y-emb space of 1200 to 1499 mm

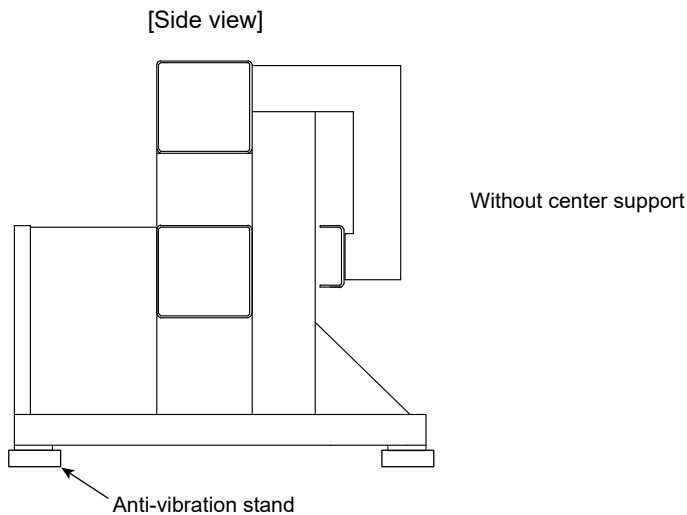

Fix the center support by using the hexagon socket head cap screw.

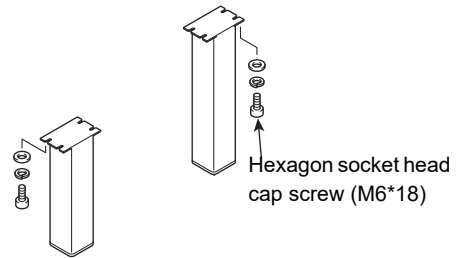

Chapter 7 Level adjusting

e. 8.5 meter machine (8,146 to 8,865 mm) with Y-emb space of 1500 mm

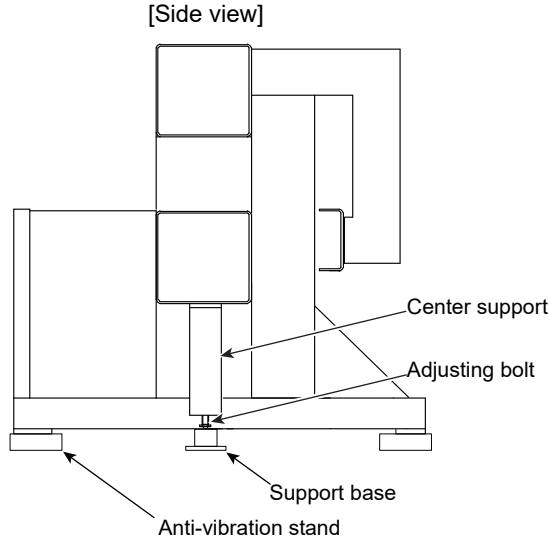

Fix the center support by using the hexagon socket head cap screw.

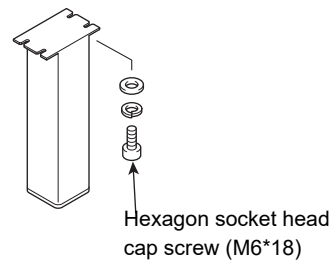

f. 9 meter machine (8,656 to 9,500 mm) with Y-emb. space of less than 1200 mm

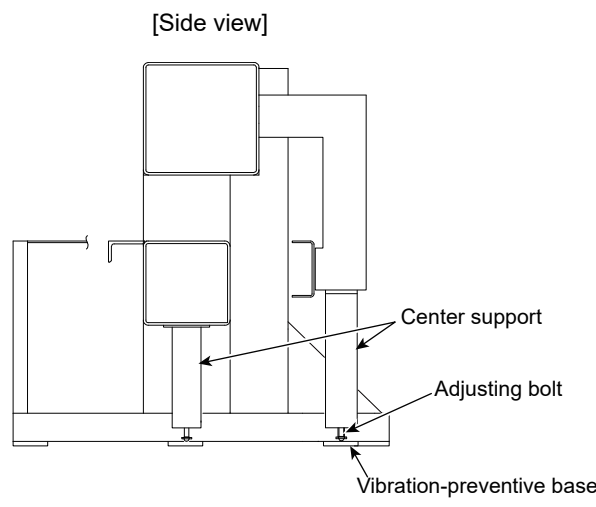

Fix the center support by using the hexagon socket head cap screw.

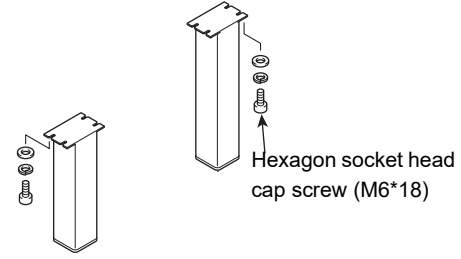

g. 9 meter machine (8,656 to 9,500 mm) with Y-emb. space of 1200 mm or larger, 10 meter machine (9,291 to 11,000 mm)

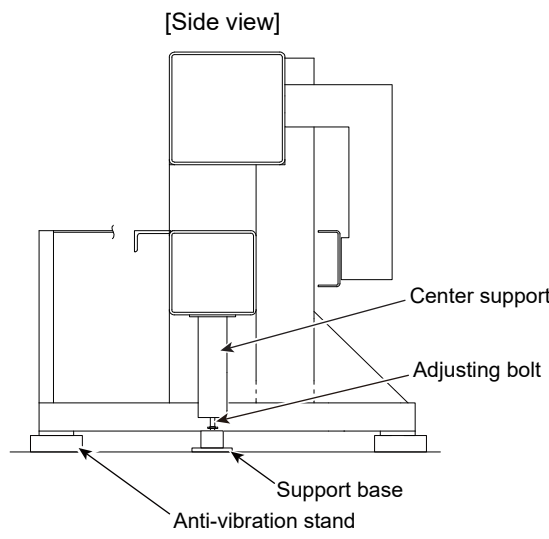

Fix the center support by using the hexagon socket head cap screw.

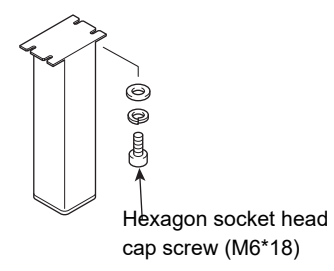

(2) Touching degree of adjusting bolt **CAUTION**

 Do not tighten adjusting bolt too much. Overtightening could change the position of lower dead point of needle bar and needle location, which could apply adverse affect to sewing.

Set the head of the adjusting bolt 1 in contact with the concave section 2 of the vibration-preventive base or the support base, then tighten the nut 3 after turning the adjusting bolt by 1/5 turn with a wrench.

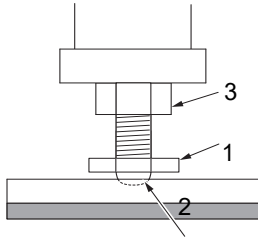

When vibration, noise etc. occur, adjust tightening degree of adjusting bolt.

2-3. Center support (L-spec. machine)

(1) Attaching spot

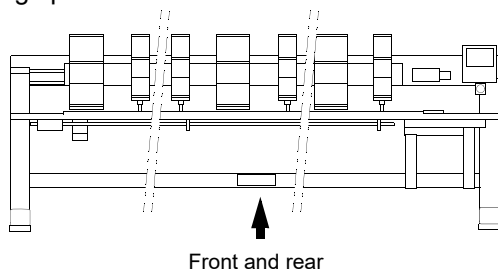

(2) Touching degree of adjusting bolt

CAUTION

-  Do not lift the center support too much. Lifting the center support too much would change needle bar lower dead point and needle locating position, which could affect sewing badly.

After making 1/4 turn by using a wrench from the position where the adjusting bolt 1 touches the concavity of the vibration-preventive base 2, tighten the nut 3.

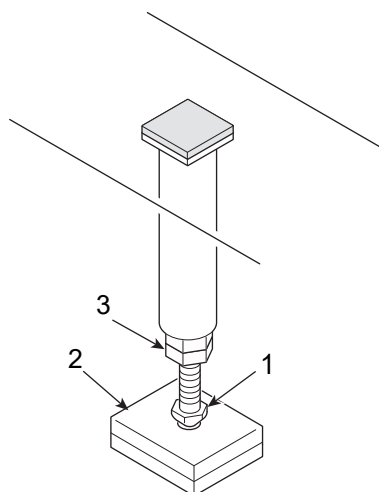

When vibration, noise etc. occur, adjust tightening degree of adjusting bolt.

Chapter 8 Adjustment

WARNING

 Perform this working with the power turned "OFF" to prevent accident resulting in injury or death and/or property damage.

1. Needle locating position

Check this working at all heads.

(The first needle and the last needle in case of FM head)

- (1) Turn the main shaft counterclockwise to lower needle bars of all heads.
- (2) Check if the needle is almost located to the center of needle hole.

FM head

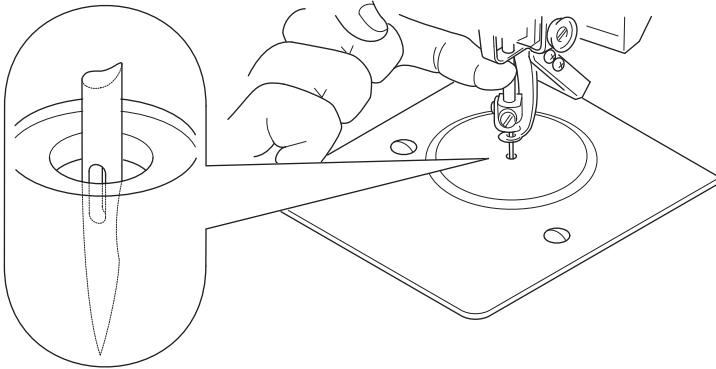

LM head

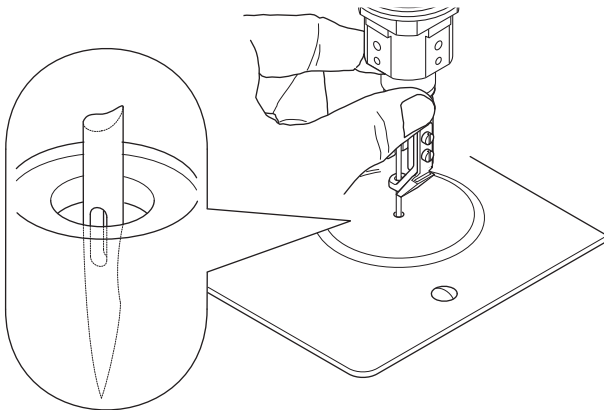

To rotate the main shaft, use the main shaft handle (accessory).



Adjust right and left positions of needle bar case. If needle locating position is misaligned between the first needle and the last needle, allocate the misalignment so that the needle location comes to the center as much as possible.



For LM head, slightly change the fixing position of the needle plate to adjust the needle locating position.

Chapter 8 Adjustment

- (3) For FM head, to adjust needle position of a certain head, adjust its needle bar case.
- (4) When needle location is misaligned at the same degree in all heads, perform the following operation (Correction of color change interval).
 - a. Press F3 while pressing "SET" to select "5 Correction of Color Change Interval".
 - b. Change the value and allocate needle locating position so that the first needle and the last needle come to the center as much as possible.

5 Correction of Color Change Interval +0.01mm



Value described on the label is registered (Value at shipment).

- c. Correct the value described on the label to the value after change. It is necessary to register this value after installation of software.

2. Lower dead point

Check this working at all heads. (In case of FM head, check all the needle bars from the first needle to the last needle)

- (1) Turn the main shaft counterclockwise, and set the main shaft angle to lower dead point "178°" while lowering the needle bar.
- (2) Check the lower dead point. (At the first needle in case of FM head)

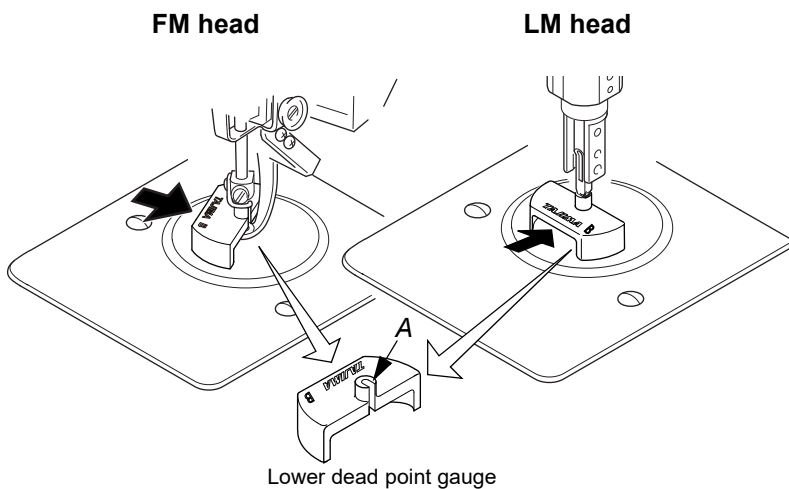

Move the lower dead point gauge like above figure so that the needle puts into the groove (A). At this moment, check if the lower dead point gauge has no play in up and down direction.

To adjust a certain head, loosen the screw 1 (right and left two spots) to slide the needle bar case right and left.

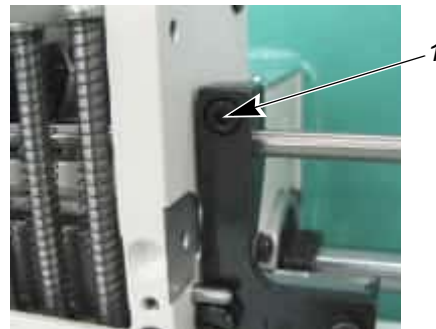

Fix the main shaft during working. Loosen the hexagon bolt 3 to make it touch to the pulley 4.

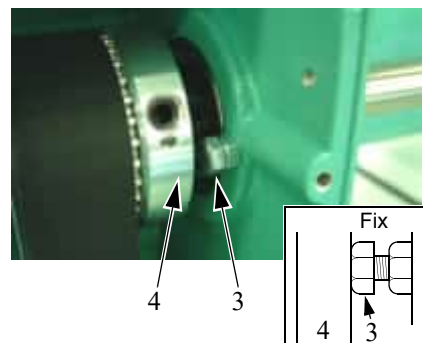

When the working is finished, be sure to return the hexagon bolt to the original position before turning ON the power.

(3) Check**a. FM head:**

Use the lower dead point adjusted for the first needle as the reference position, and check the lower dead point for the second and subsequent needles by using the connecting stud gauge.

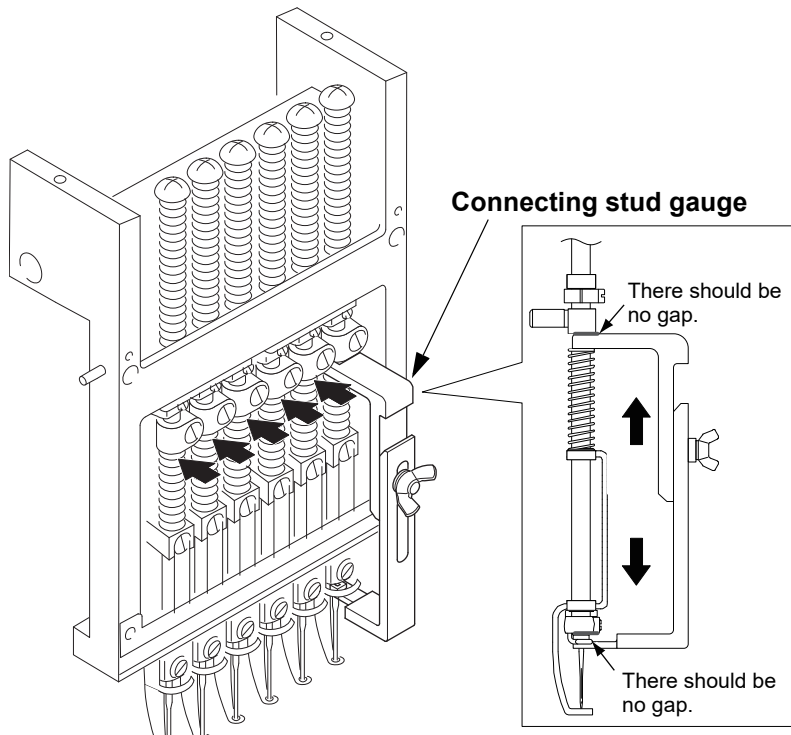
**b. LM head:**

Set the lower dead point gauge correctly in the state of main shaft angle set to 178° . Loosen the screw 1 and push up the needle bar. After that, tighten the screw 1.

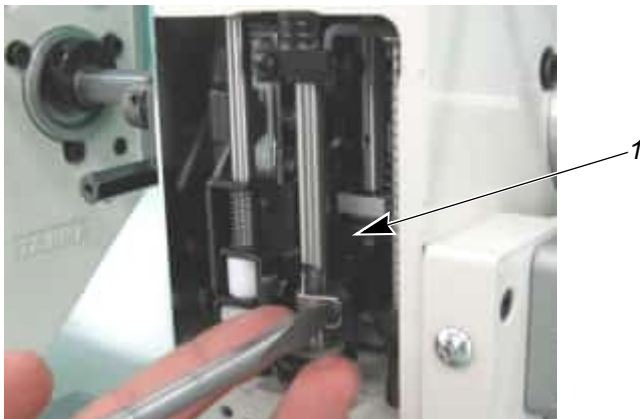

Perform also adjustment of upper dead point at the needle bar whose lower dead point is adjusted (p.36).

3. Upper dead point

3-1. FM head

- (1) Turn the main shaft counterclockwise, and set the main shaft angle to 7° while raising the needle bar.
- (2) Loosen the screw 3 of the upper dead point stopper 1.
- (3) Tighten the screw 3 of the upper dead point stopper 1 in the state of the upper dead point stopper 1 touched with the cushion ring 2 lightly.

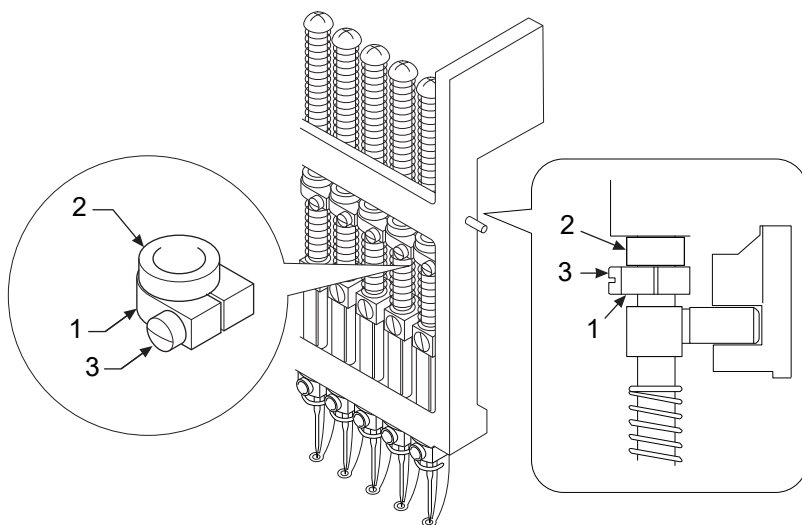

Although the upper dead point of this machine is 0° , the upper dead point stopper 1 is fixed at the position where the upper dead point stopper 1 touches the cushion ring 2 at main shaft angle 7° in production at the factory.



Fixing of the screw 3

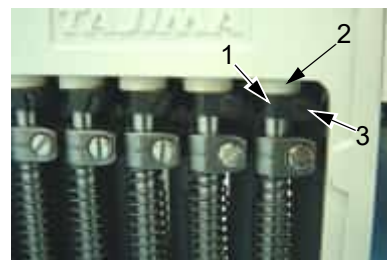

3-2. LM head

- (1) Turn the main shaft counterclockwise, and set the main shaft angle to 7° while raising the needle bar.
- (2) Loosen the screw 1.
- (3) Loosen the screw 1 in the state of the upper dead point stopper 2 touching the damper ring 3 lightly.

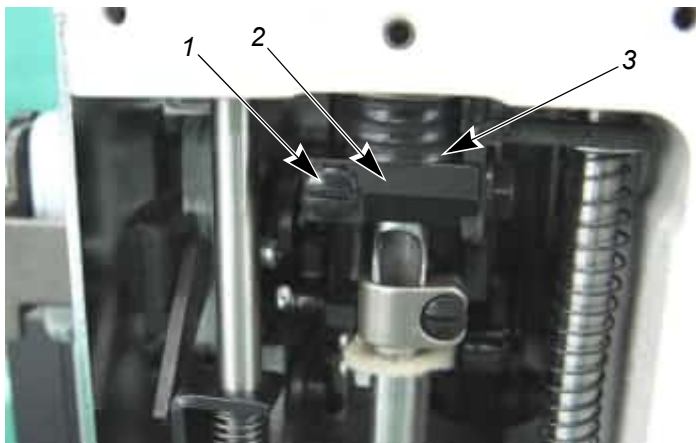

Although the upper dead point of this machine is 0° , the upper dead point stopper 1 is fixed at the position where the upper dead point stopper 2 touches the damper ring 3 at main shaft angle 7° in production at the factory.

4. N-Pipe Lower Dead Point

- (1) Set N-Pipe stroke to "0" by "Manual N-Pipe stroke change (F6-1)" (Setting on the operation panel).
- (2) Turn ON/OFF sleep mode (To search electrical base point).
- (3) Check if the clearance (A) between the N-Pipe 1 and the needle plate 2 is 0.7 to 0.8 mm. When adjustment is necessary, proceed to the next.

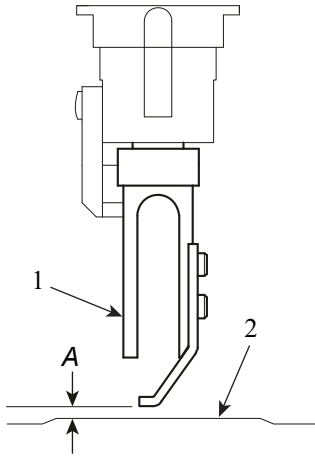

- (4) Loosen the screw 1 to slide the N-Pipe holder 2 up and down so that N-Pipe position is adjusted.

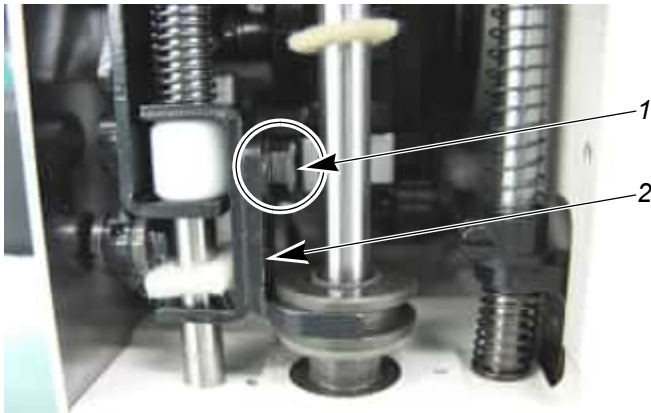

Sleep mode ON: keep on pressing the sleep mode key for two seconds during stop of the machine.

Sleep mode OFF: press this key in the state of sleep mode.

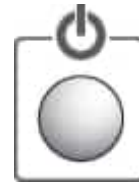

5. Bevel gear

Check play of the bevel gear 1 and the bevel gear 2 at all heads. It is normal if the bevel gear 2 moves slightly (0.1 to 0.2 mm).

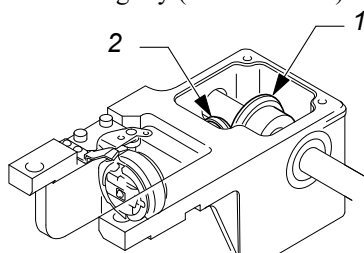

If there is no "play", loosen the set screw of the bevel gear 1 to adjust position of the bevel gear 1.

6. Needle and rotary hook

Check this working at all heads.

(Check at the first needle and the last needle in case of FM head.)

- (1) Turn the main shaft counterclockwise and set it to the position (198° to 204°) where the needle tip 1 meets the hook point of rotary hook 2.
- (2) Check if the gap (A) between the scarf of needle 3 and the hook point of rotary hook 2 is 0.1 to 0.3 mm.

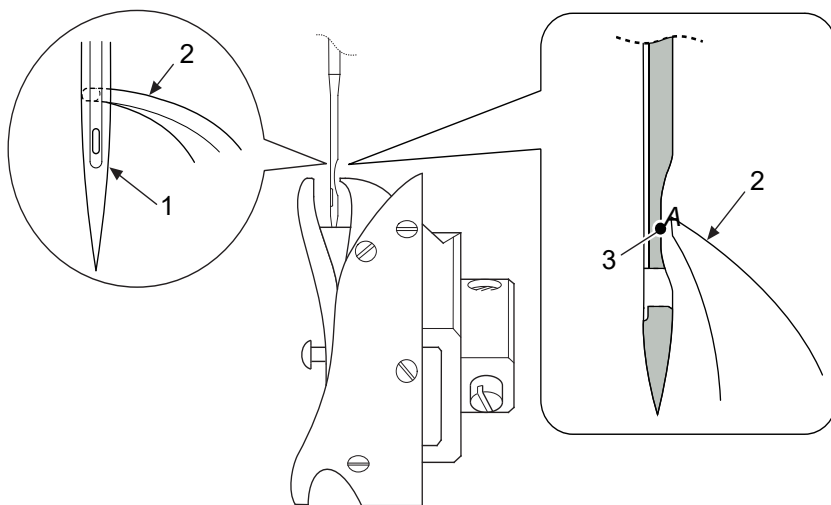

Push the needle lightly using a flat head driver.



Chapter 9 Idling and test sewing

1. Lubrication

CAUTION

- ! When performing lubrication, use only Tajima's genuine TF oil (packed with the machine). If you use other oil than this by necessity, select oil equivalent to ISO viscosity grade: VG20.
- ! After the working, attach all covers that were detached.

FM head

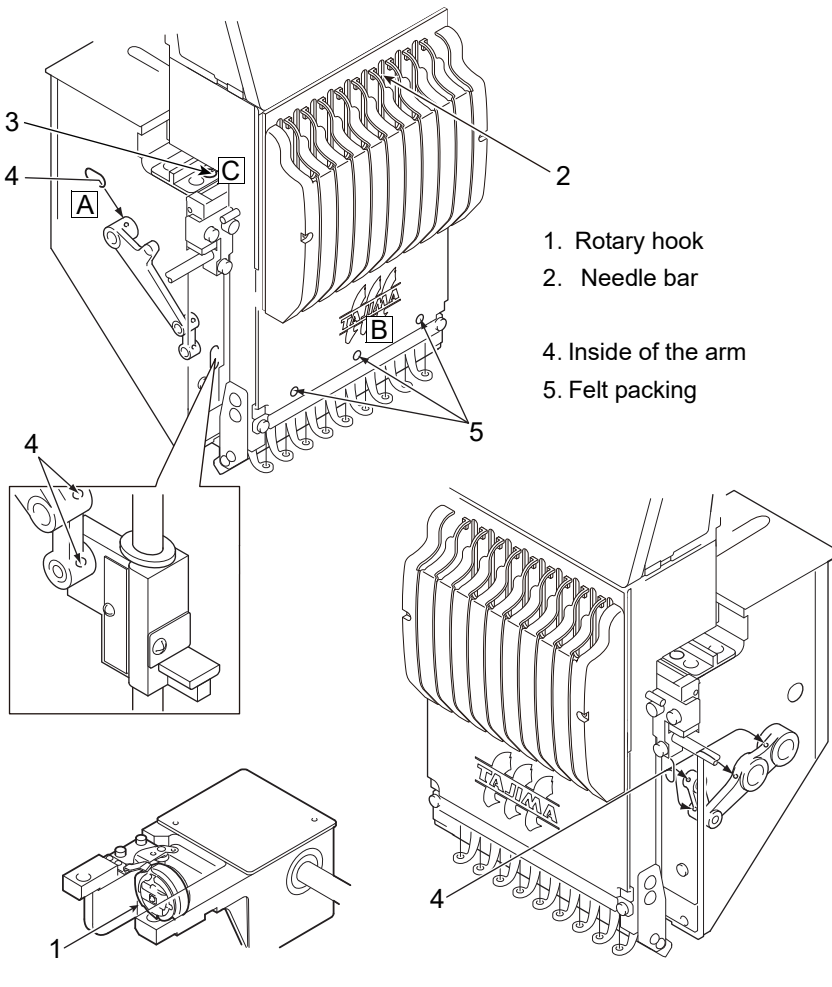

Lubricate two spots of rotary hook. To lubricate to the lubrication hole 2, attach the accessory lubrication nozzle 3 to the oiler. Cut the tip of the nozzle according to necessary length.

Rail section 1

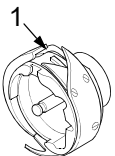

Lubrication hole 2

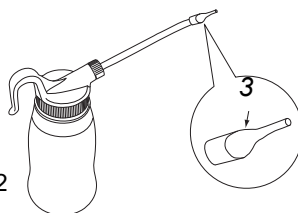
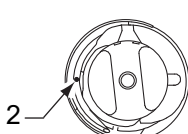

If the machine is equipped with automatic lubrication system, perform "manual lubrication".



Some covers and parts are removed for taking pictures.



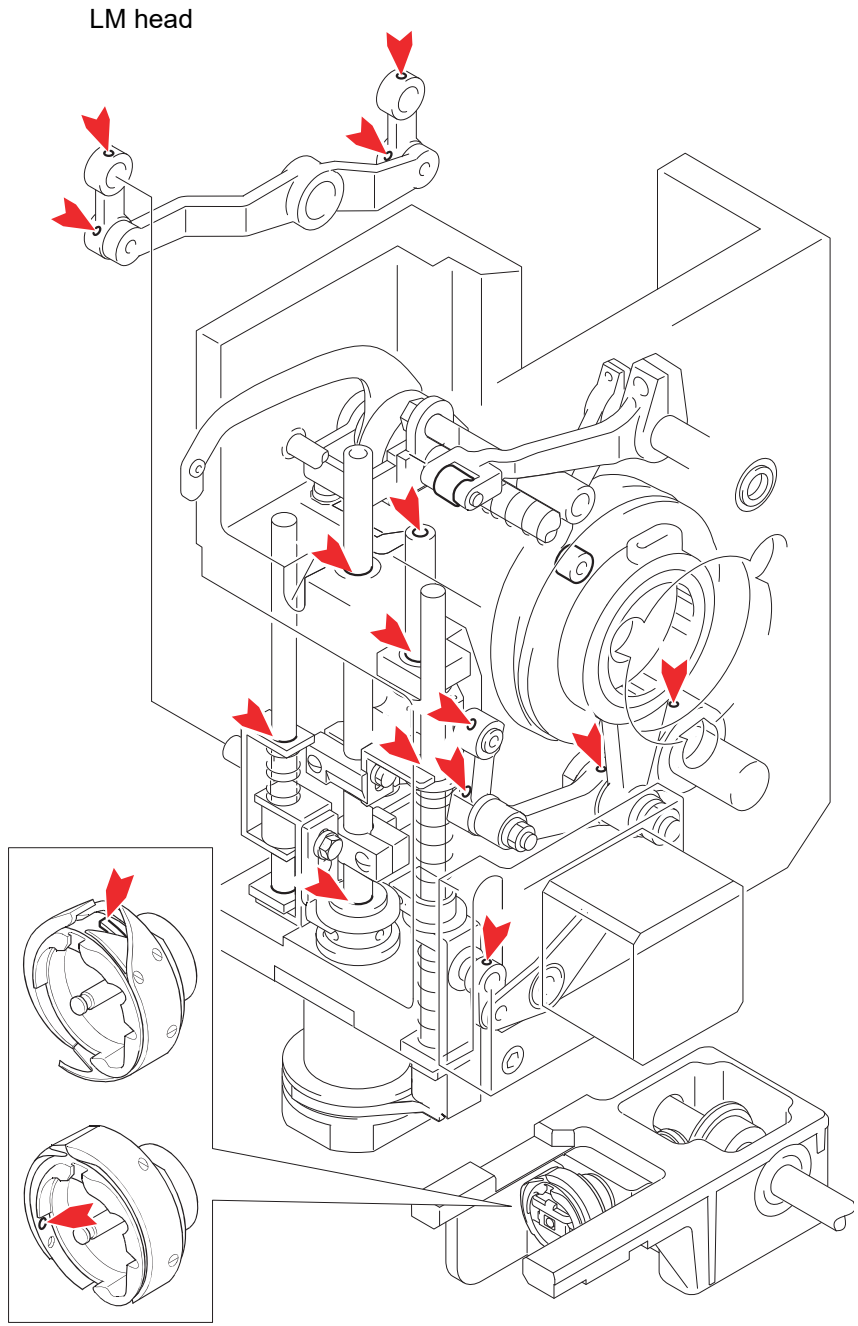

An example of lubricating spots

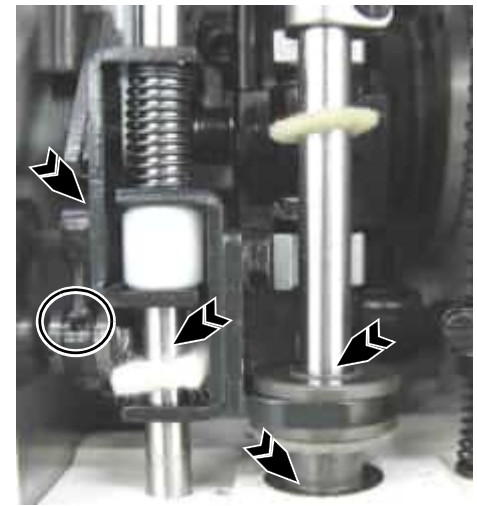
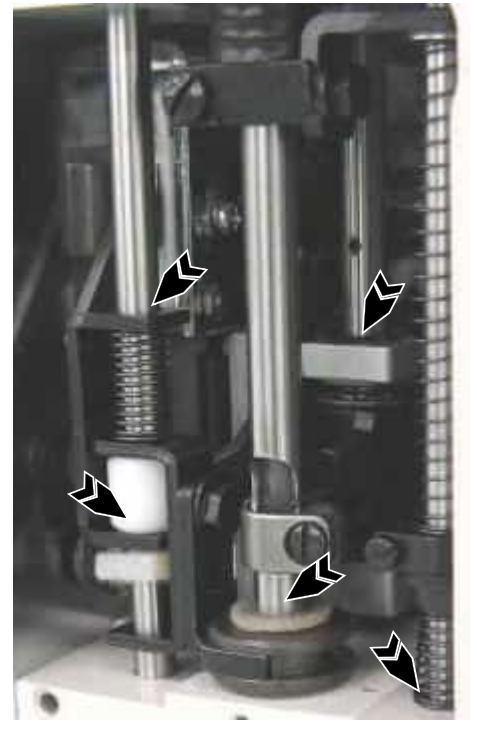

Lubricate two spots of rotary hook. To lubricate to the lubrication hole 2, attach the accessory lubrication nozzle 3 to the oiler. Cut the tip of the nozzle according to necessary length.

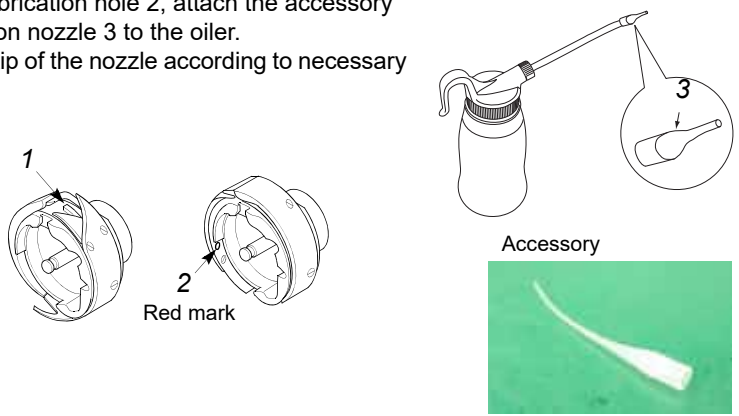

2. Idling, jump

CAUTION

- ❗ To operate the machine, check if there is no person around moving section and all covers are attached to prevent accident resulting in injury or death.
- ❗ Keep on idling until antirust applied on rotary hook is completely removed. If antirust remains, it causes thread breakage.

- (1) Set “not to detect” “Upper thread breakage detection” and “Under thread breakage detection” in parameter setting of FM head and/or LM head.
(Operation on the operation panel, FM head: F2▶6 , LM head: F2▶7)
- (2) Set a design of which data contains jump codes.
- (3) Start the machine to perform idling. At the beginning, start the machine with about 250 rpm or so and increase the speed up to 650 rpm while checking running condition of the machine. Spare time for 20 to 30 minutes for operation. Check if no misjumping occurs using design data that includes jump codes.
- (4) When working is finished, check if no heat occurs from needle bar case, side face of arm, needle bar drive shaft etc. Then, return frame drive to ON.

3. Threading

3-1. FM head

(1) First tension

Attach the accessory spiral tube 1. To pass thread, use the accessory threader 2 and disconnect the top of the spiral tube 1 once.

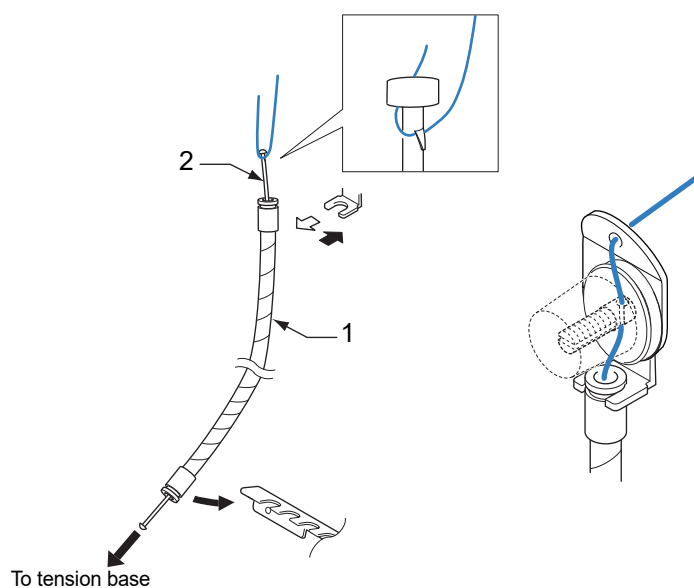

Regarding the machine equipped with automatic lubrication system, set lubrication cycle to 1,000 stitches, and then perform idling. After completion of the work, return the setting to the original value.



When misjumping occurs, it is necessary to adjust the position of upper dead point stopper (p.36).



In the state of spiral tube attached



Threader



(2) Tension base

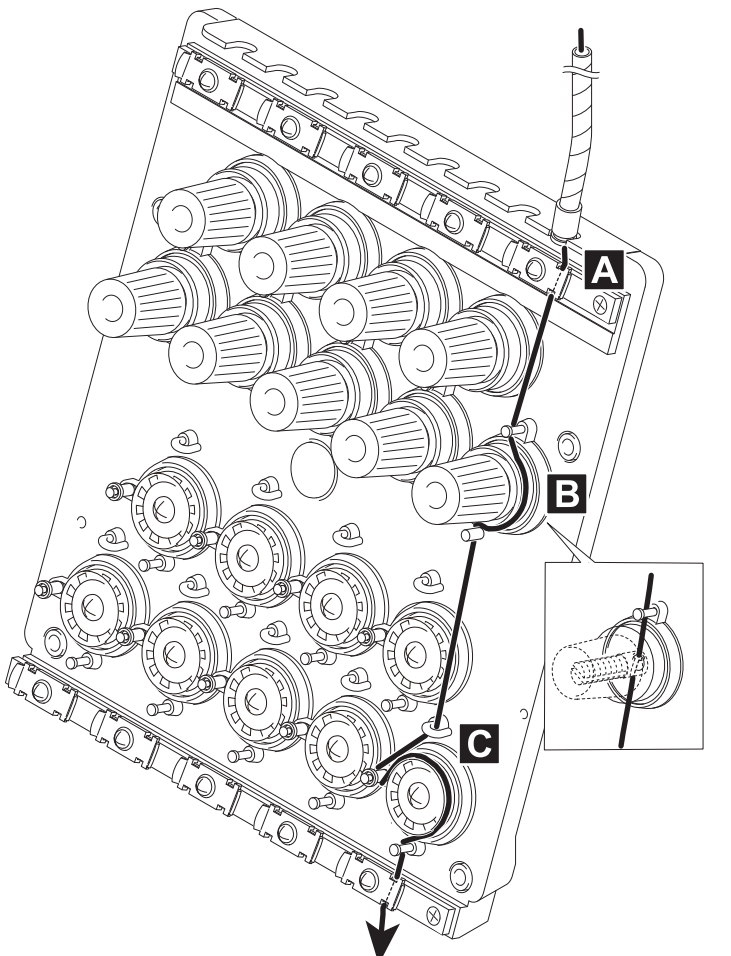

To the take-up lever, snap-fit middle thread guide

(3) Take-up lever, snap-fit middle thread guide

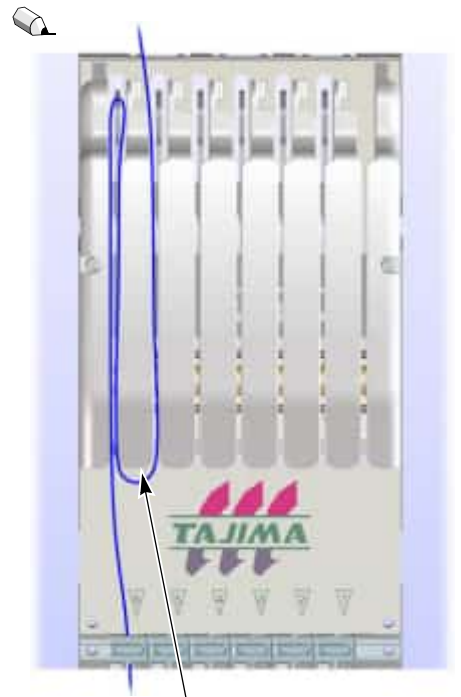
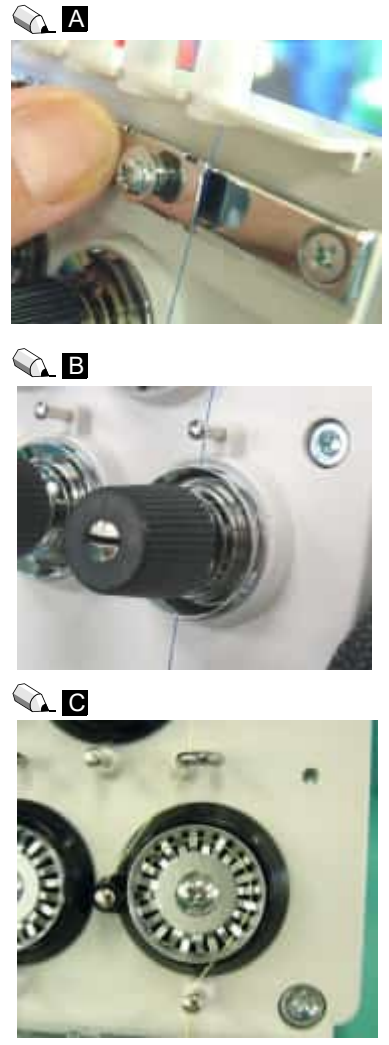
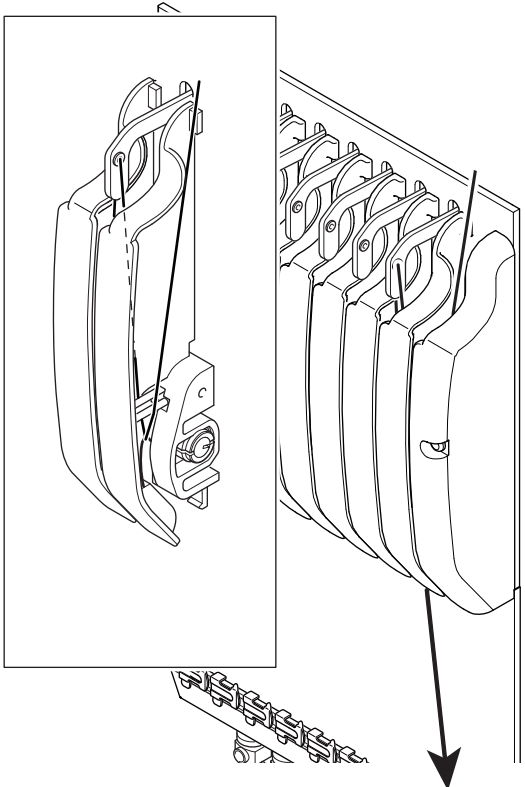

It is possible to perform threading easily by just hooking the thread here.

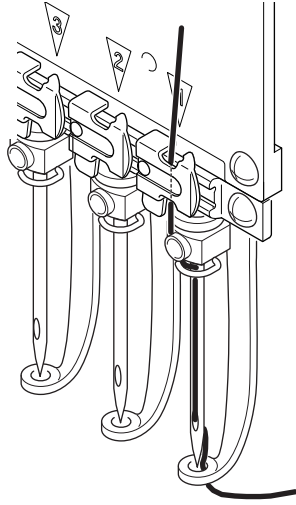
(4) Upper thread lock, needle

Threading is completed.



3-2. LM head

As the figure below shows, there are two types [a] and [b] of tension part and threading is different. Therefore, pay attention.

(1) Usual threading

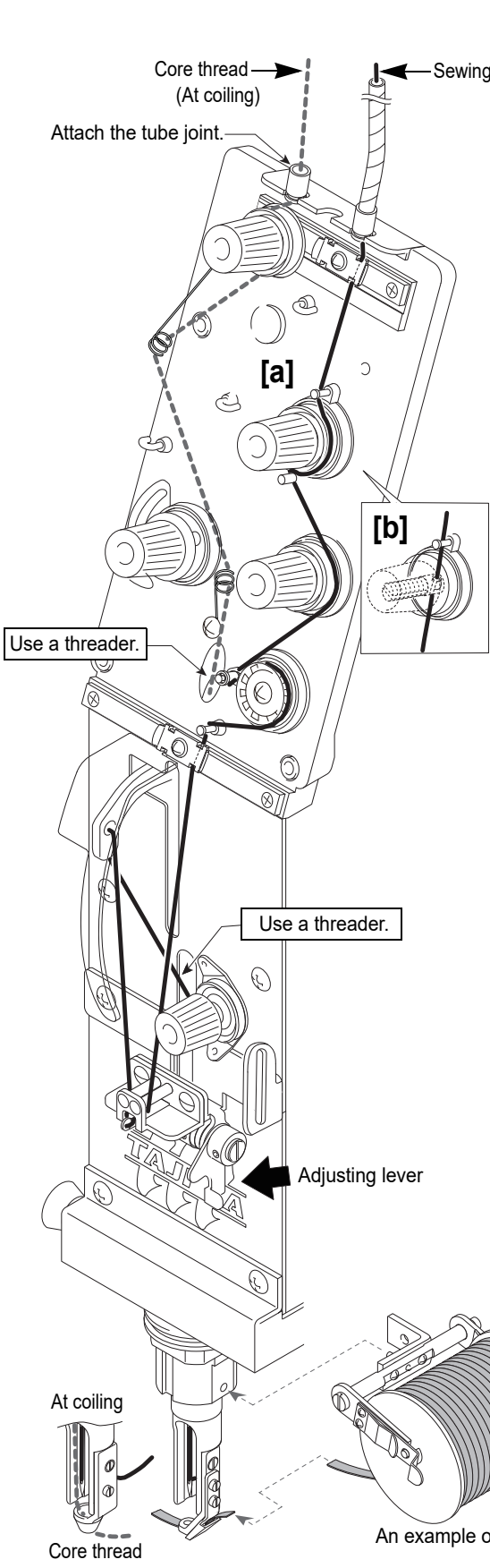

How to use adjusting lever
When passing thread

(1) To raise the lever

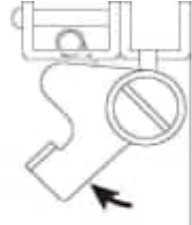

(2) To pass thread

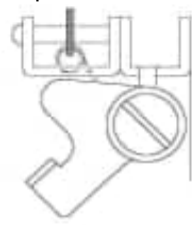

(3) To return it to the original position

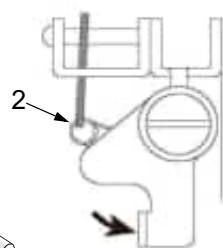

When the stroke of the thread take-up spring 2 increases, thread tension will be stronger. Select position of the lever according to finish of sewing.

Core thread (at coiling)



Raise the lever before threading.



After threading, return the lever to the basic position where the screw 1 faces to the front.

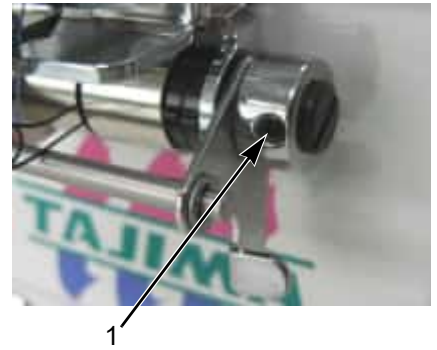

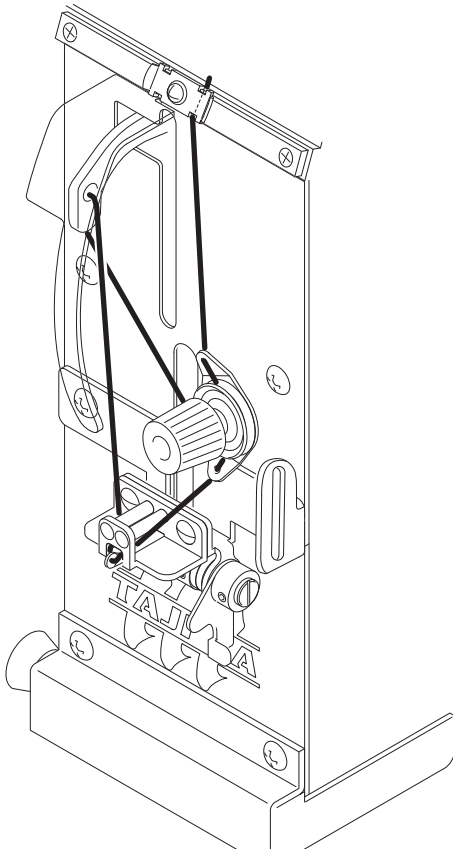
(2) Threading when you want to strengthen thread tension

- (3)** To strengthen thread tension more, attach the take-up lever adjuster using the screw.
It is also possible to adjust thread tension by moving up/down the position of the take-up lever adjuster loosening the screw.

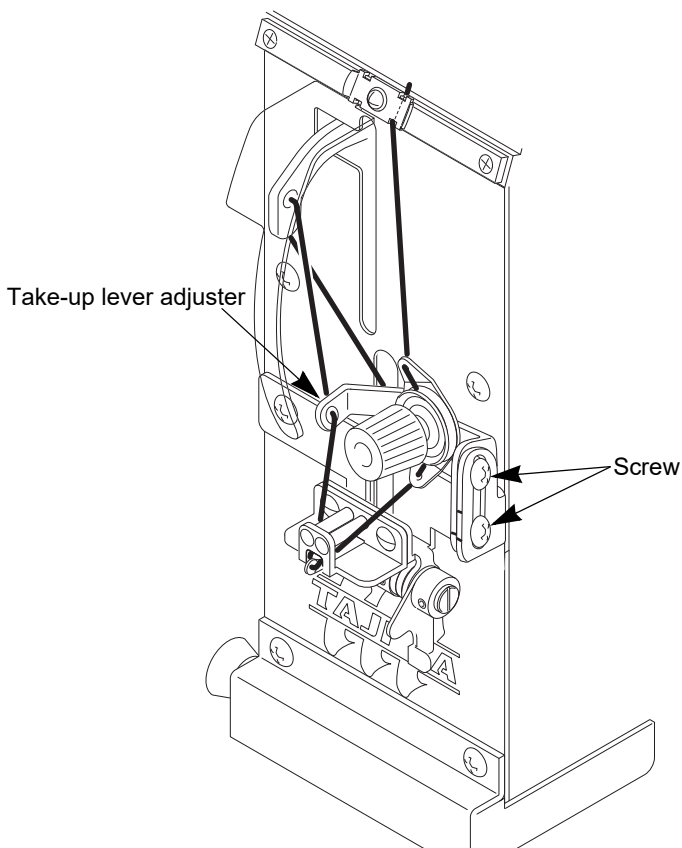

When you want to strengthen thread tension more, proceed to (3).



Followings are examples for adjusting the position of the take-up lever adjuster. The positions differ depending on the type of rotary hook. Moving up will strengthen thread tension.

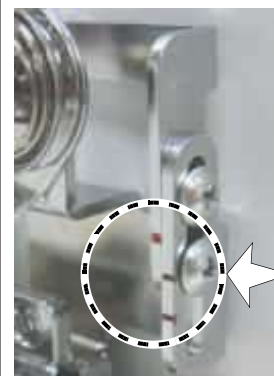
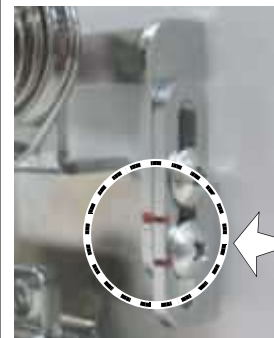

4. Test sewing

Stretch fabric to the frame, set under thread bobbin and check each movement such as color change, manual ATH etc. Then, start test sewing.

When a trouble occurs at test sewing, refer to “17. Troubleshooting” of the “User’s Manual”.



CAUTION



For long life machine operation, operate the machine with about 70% of the maximum speed as “operation for total fitting” for about two weeks after installation. By performing operation for total fitting, life of the machine will become longer, which will be useful to avoid unexpected troubles.



1st Edition December, 2007

19th Edition April, 2022

■ **Manufactured by: TISM Co.,Ltd.**

Address : NO.1800, Ushiyama-cho, Kasugai, Aichi-pref., 486-0901, Japan
TEL : 81-568-33-1161 Fax : 81-568-33-1191

■ **Distributed by: Tajima Industries Ltd.**

Address : NO.1800, Ushiyama-cho, Kasugai, Aichi-pref., 486-0901, Japan
TEL : 81-568-37-1130 Fax : 81-568-37-1230

●**Copy, reprint, or reform of a part or whole of this manual without permission is prohibited.**