

MACHINE SETUP INSTRUCTIONS

PAX-VF

PAR-VF

HAR-VF

[IMPORTANT]

**To handle the machine correctly and safely,
perform operations according to the procedure
described in this manual.**



User's Manual / Parts List

User's manual / Parts list are stored as the PDF file in the accessory DVD.

Please read the contents thoroughly and then use the machine or the optional device.

To see the PDF file, "Adobe Acrobat Reader" is necessary.

User's manual, parts list of the optional devices you have not purchased are included in this DVD.
Please note beforehand.

[How to open the DVD]

1. Insert a DVD into the personal computer.



Since the following pop-up window will be displayed automatically, select "Open folder to view files" (indicated by the arrow).

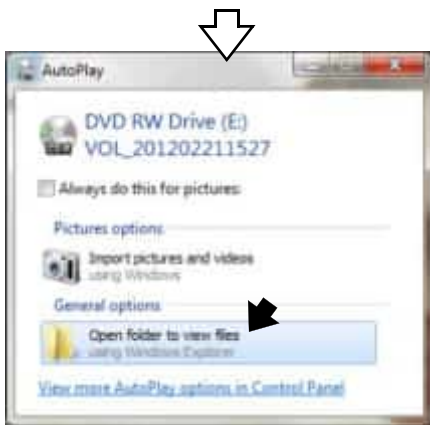

2. Double-click left "titlepage".

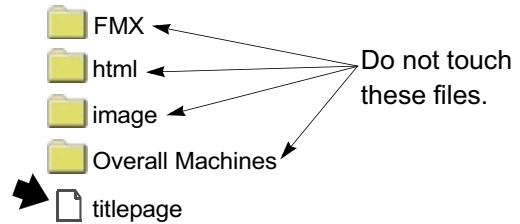

3. Select displaying language.



4. Select "User's Manual" or "Parts List", and then select the title you desire.



The figure above is an example selecting "English (Multiple Languages)" in the above 3.

Foreword

This manual introduces the procedure for setup of PAX-VF, PAR-VF and HAR-VF.

Please read this manual thoroughly and operate the machine after you understand the contents.

This manual may contain discrepancies in detailed specification as compared with the actual production.

If you have any question about this manual, consult your TAJIMA distributor.

Regarding the optional device, refer to the USER'S MANUAL for the device (separate volume) .

Please keep this manual with care near the machine for quick reference.

TISM Co.,Ltd.

SAFETY PRECAUTIONS

To prevent any harm or damage to the person who use this product or other person, we describe items that must be surely followed as below.



Indicates that there is a lot of danger of death or serious injuries [*1] if handled by mistake.



Indicates that there is a likelihood of death or serious injuries [*1] if handled by mistake.





Indicates a potentially hazardous situation which may result in minor or moderate injury [*2] or property damage if handled by mistake.

*1: A condition caused by electric shock, injury, fracture of a bone, etc., that leads to aftereffects, or an injury that necessitates hospitalization or visits to a hospital over a long period.

*2: An injury that does not necessitate hospitalization or visit to a hospital over a long period.

: Prohibited items

: Items that may cause electric shock if not observed

: Items that must be followed carefully to ensure safe operation



MUST DO LIST AT MACHINE INSTALLATION

MODEL:	M/NO.:
DATE / / / PIC:	

Check the following items in order after “Chapter 5 Level adjustment”.

Chapter 6 Adjustments	Remarks	✓
H head (PAX、 HAR)		
1-1. H head needle location (PAX, HAR)	Check and adjust the needle locating position. <ul style="list-style-type: none"> • The 1st needle on all heads • The last needle on all heads Equalize it at the 1st needle and the last needle.	
1-2. Needle bar lower dead point adjustment (Input of the password is necessary)	Check and adjust the lower dead point.	
1-3. Adjustment of upper dead point (Input of the password is necessary)	Check and adjust the upper dead point.	
1-4. Adjusting height of presser foot (Input of the password is necessary)	Check and adjust the height of presser foot.	
1-5. Screw gear	Check and adjust screw gears gap.	
1-6. Needle and rotary hook	Check and adjust the needle and the rotary hook timing and the gap.	
P head (PAX、 PAR)		
2-1. Needle bar lower dead point adjustment (Input of the password is necessary)	Check and adjust the lower dead point.	
2-2. Adjustment of upper dead point (Input of the password is necessary)	Check and adjust the upper dead point.	
2-3. Adjusting height of presser foot (Input of the password is necessary)	Check and adjust the height of presser foot.	

Chapter 7 Idling and test sewing	Remarks	✓
1. Lubrication	Lubricate to the rotary hook and the inside of the arm.	
2. Idling, jump	Run the machine at least 20 minutes without threads for all needles to remove anti-rust liquid from the rotary hook.	
	Check if the reciprocator catches the needle bar stud at inching.	
	Check if the jump device operates properly.	
3. Test sewing	<p>H head: Check if the thread breakage or the needle breakage occurs.</p> <p>P head: Attach the plastic sheet (PP sheet) to the frame, and put the leather on it, then perform punching.</p>	

Chapter 1 Carrying

1.	Installation environment.....	1
2.	How to install	2
2-1.	When using a crane.....	2
2-2.	When using a forklift	2
2-3.	Installation.....	3
3.	Removing the stopper.....	4
3-1.	Single-head machine	4
3-2.	Multi-head machine	5

Chapter 2 Attaching

1.	Operation panel	6
2.	Table support (limited model)	8
3.	Thread course.....	9
3-1.	HAR	9
3-2.	PAR	9
3-3.	PAX (two or more pairs), PAR (two or more heads).....	10
4.	Nylon tube.....	11
4-1.	Needle bar case.....	11
4-2.	Manifold cover (standard spec.)	15
5.	Synchronized vacuum system (option).....	16
5-1.	Synchronized vacuum system	16
5-2.	Extension device controller	17
5-3.	Parameter setting confirmation.....	18
6.	Auto. PP Tape Feeder (option).....	19
6-1.	Tape feed unit.....	19
6-2.	Installing PP tape.....	21
6-3.	Extension device controller	24
6-4.	Parameter setting confirmation.....	25
7.	Hose and Vacuum Device	26
7-1.	Hose	26
7-2.	Vacuum device (PAX, PAR)	28

Chapter 3 Connection of power cord

1. Important safety instructions..... 30

Chapter 4 Operation panel settings

1. Parameter setting 32
2. Absolute origin search 33

Chapter 5 Level adjustment

1. Level adjustment 34

Chapter 6 Adjustments

1. All sorts of adjusting methods for H head (PAX, HAR)..... 37
 - 1-1. H head needle location (PAX, HAR) 37
 - 1-2. Needle bar lower dead point adjustment (Input of the password is necessary) 38
 - 1-3. Adjustment of upper dead point (Input of the password is necessary)..... 44
 - 1-4. Adjusting height of presser foot (Input of the password is necessary) 47
 - 1-5. Screw gear 50
 - 1-6. Needle and rotary hook 51
2. All sorts of adjusting methods for P head (PAX, PAR)..... 53
 - 2-1. Needle bar lower dead point adjustment (Input of the password is necessary) 53
 - 2-2. Adjustment of upper dead point (Input of the password is necessary)..... 57
 - 2-3. Adjusting height of presser foot (Input of the password is necessary) 60

Chapter 7 Idling and test sewing

1. Lubrication 64
 - 1-1. H head (PAX, HAR)..... 64
 - 1-2. P head (PAX, PAR) 68
2. Idling, jump 71
 - 2-1. H head (PAX, HAR)..... 71
 - 2-2. P head (PAX, PAR) 71
3. Test sewing 72
 - 3-1. To attach snarl-preventive parts (PAX, HAR)..... 72
 - 3-2. To thread (PAX, HAR)..... 76
 - 3-3. Test sewing 79

Chapter 1 Carrying

1. Installation environment

CAUTION

-  Install the machine on a sturdy floor.

The floor structure must be strong enough to bear the machine weight (indicated on the spec. plate). If the floor is supported by steel frames, place the machine stand on the steel beams as long as possible.

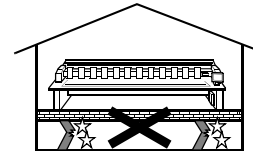

-  Control the operation noise in the environment.

This machine is designed to reduce noise during operation. To improve the sound insulation performance in the factory still more, use the interior finish materials which show high sound insulating performance for the walls, ceiling, and floor of the factory.

-  Avoid direct sunlight.

If the machine is exposed to direct sunlight over an extended period of time, the machine body may be discolored or deformed. Put curtains or shades to the sight to prevent the machine from direct sunlight.

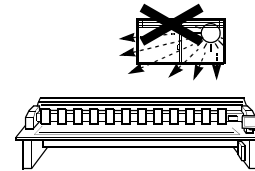

-  Provide enough space for maintenance.

Taking account of workability when maintaining and inspecting the machine, provide 50 cm or more working area to right, left and rear directions of the machine against obstacles such as walls.

-  Avoid dust and moisture.

Since dust and moisture lead to dirt and rust on the machine, use the machine in an environment of facility of air conditioner, and clean the working place periodically. Use with caution not to expose the machine to direct wind from the air conditioner so that sewing threads do not become disheveled.

Degree of pollution: 2 or less

Humidity: 30 to 95%RH (relative humidity) without condensation

Ambient temperature: 5 to 40°C (during operation), -10 to 60°C (during storage)

-  Pay attention to interference of radio wave.

Although the machine is designed not to apply radio wave to other equipment, there could be cases where it causes radio wave interference depending on operation environment and type of equipment. If such problems arise, install the equipment as apart from the machine as possible.

-  Pay attention to power supply style.

When supplying the power, meet the following requirement.

Excess voltage category: III

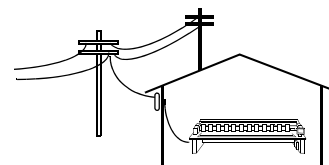

2. How to install

2-1. When using a crane

⚠ DANGER

⚠ When suspending (lifting) the machine, make sure that there is no person standing in the danger area around the machine, especially under the machine.

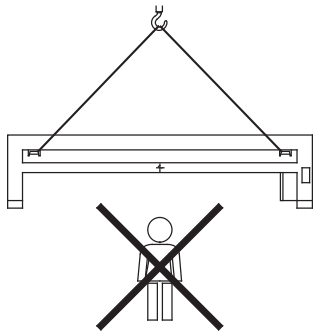

2-2. When using a forklift

⚠ WARNING

⚠ When suspending the machine, attach the anti-come-off bolts so that the nylon slings do not come off.

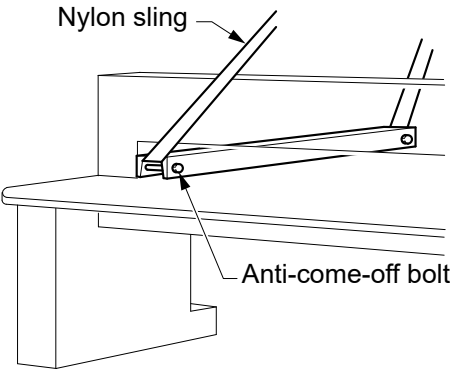

⚠ When suspending the machine, use a nylon sling that is long enough to provide a sling angle of 50° or more so that the nylon slings do not touch the table.

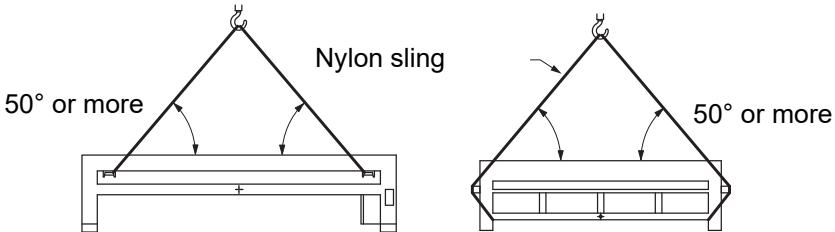

2-3. Installation

- (1) Place the vibration-preventive base under the stand.

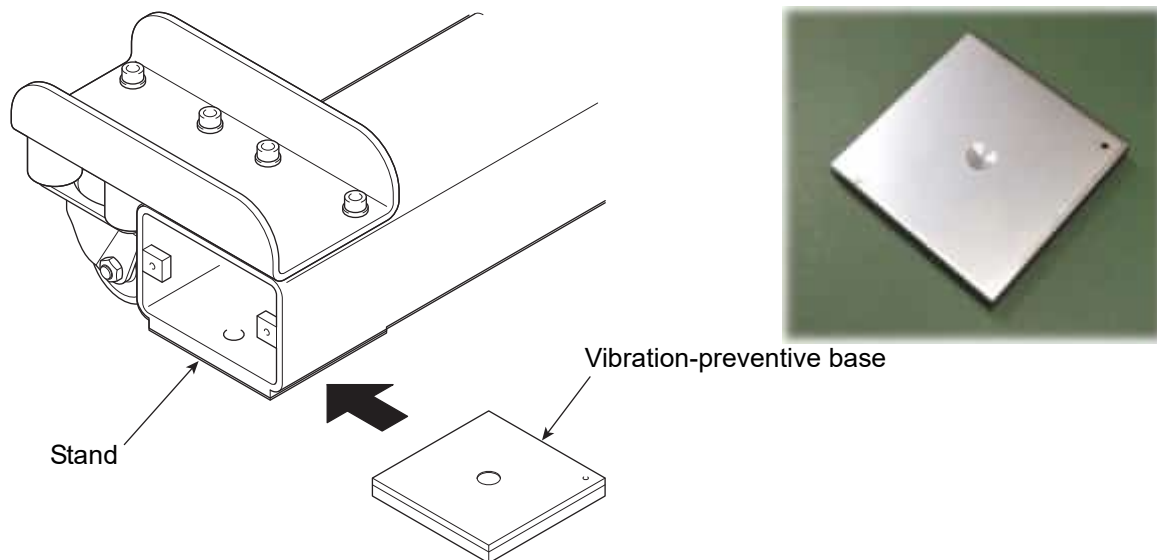

- (2) Thrust the leveling bolt into the stand until the caster lifts up. The level adjustment will be explained at another chapter. (Refer to p.34)

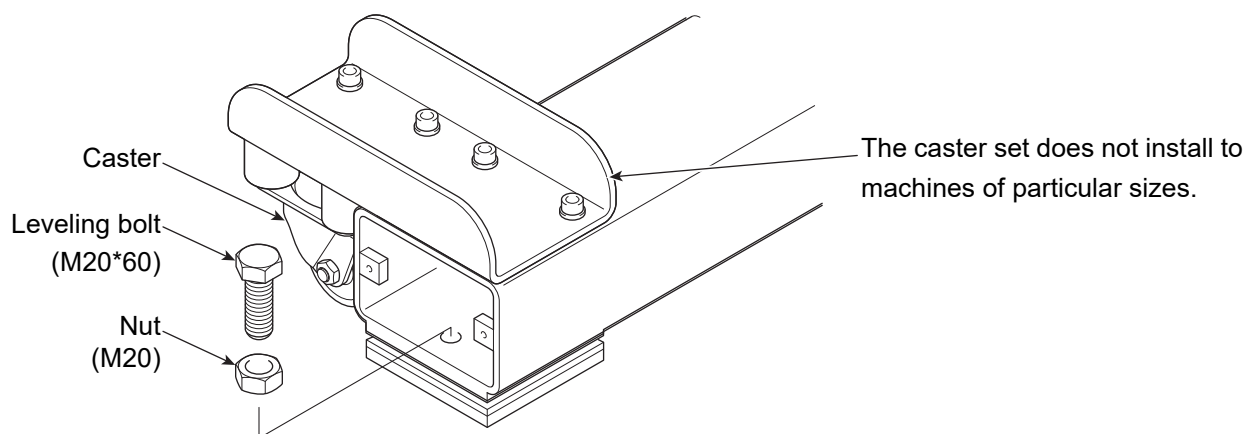

3. Removing the stopper

3-1. Single-head machine

Detach the stopper. The stopper is equipped at the left side of the change device.

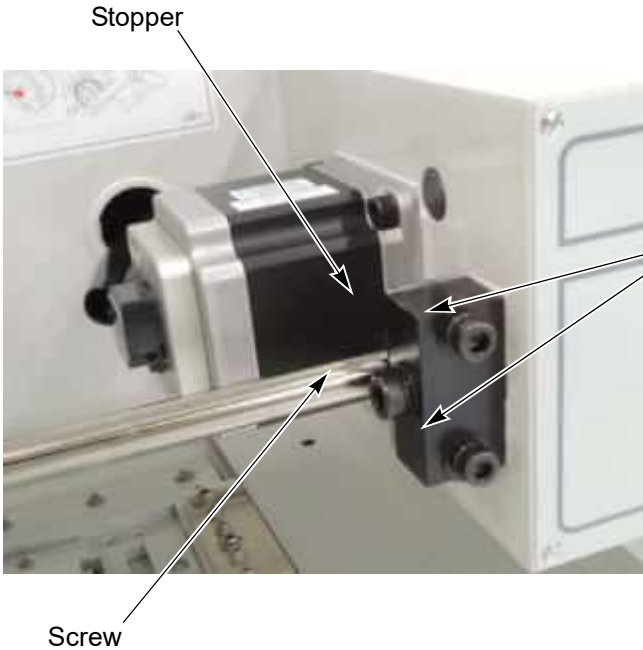
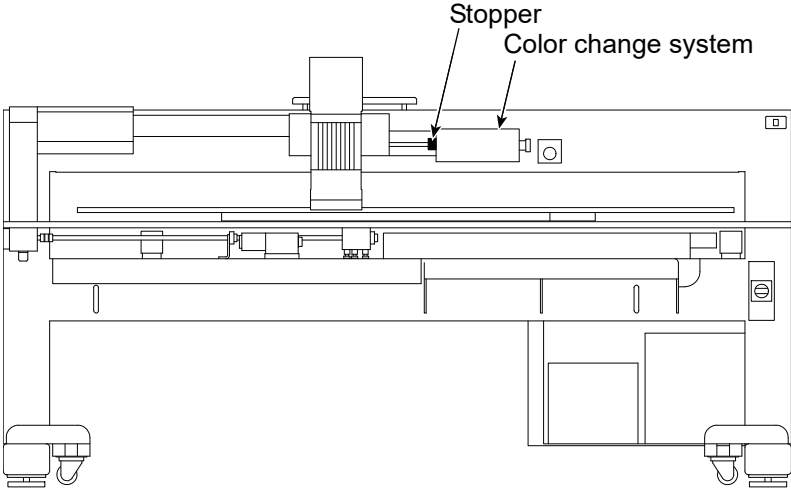

Remove screws at three spots and detach the stopper.



3-2. Multi-head machine

Detach the stopper. Attaching position of the stopper differs depending on model. Detach all covers at the beginning and check the attaching position of the stopper.

[An example of attaching spot]

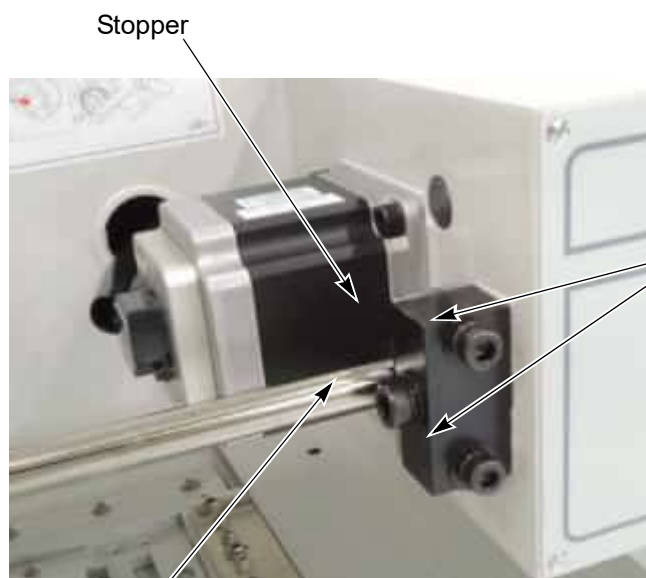
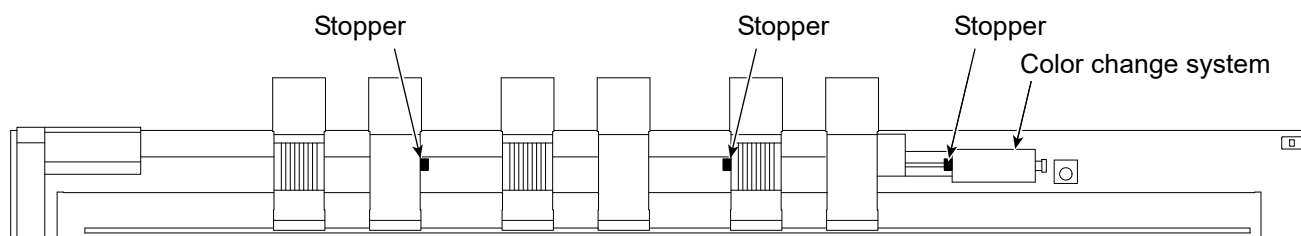

Remove screws at three spots and detach the stopper.



Chapter 2 Attaching

1. Operation panel

(1) Loosen the knobbed screw and install the operation panel on the pipe.

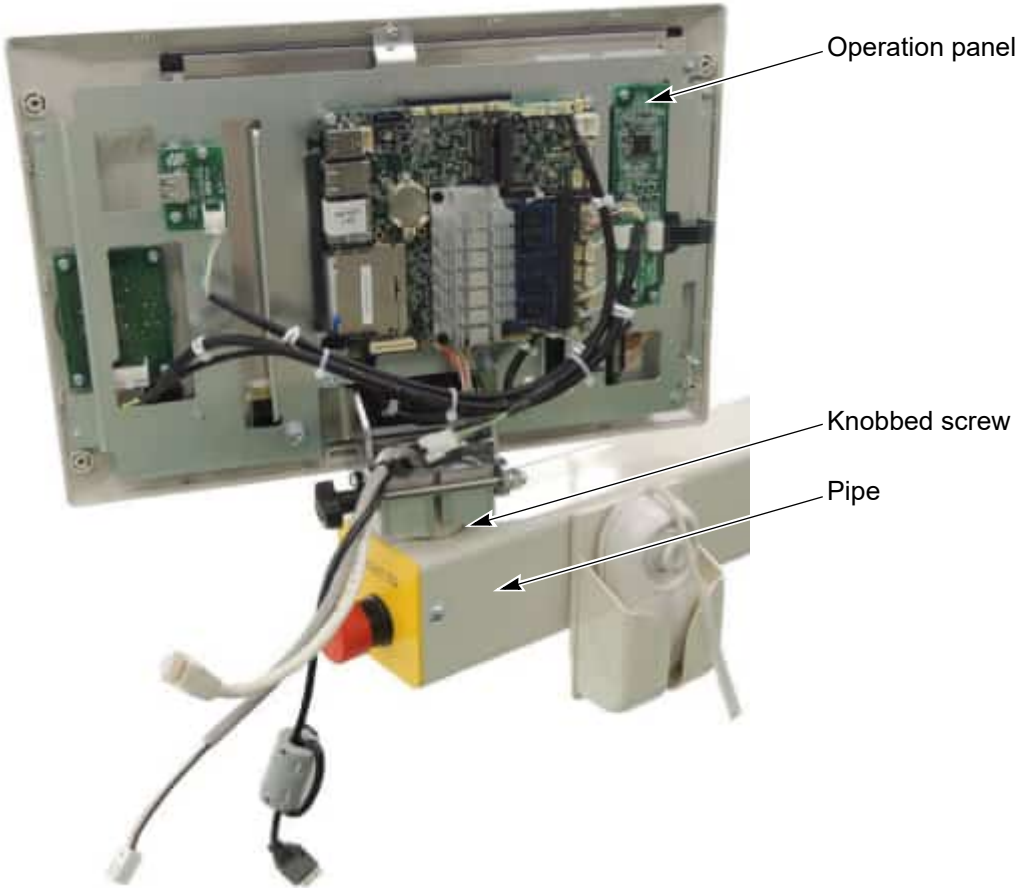

(2) Connect harnesses to the operation panel.

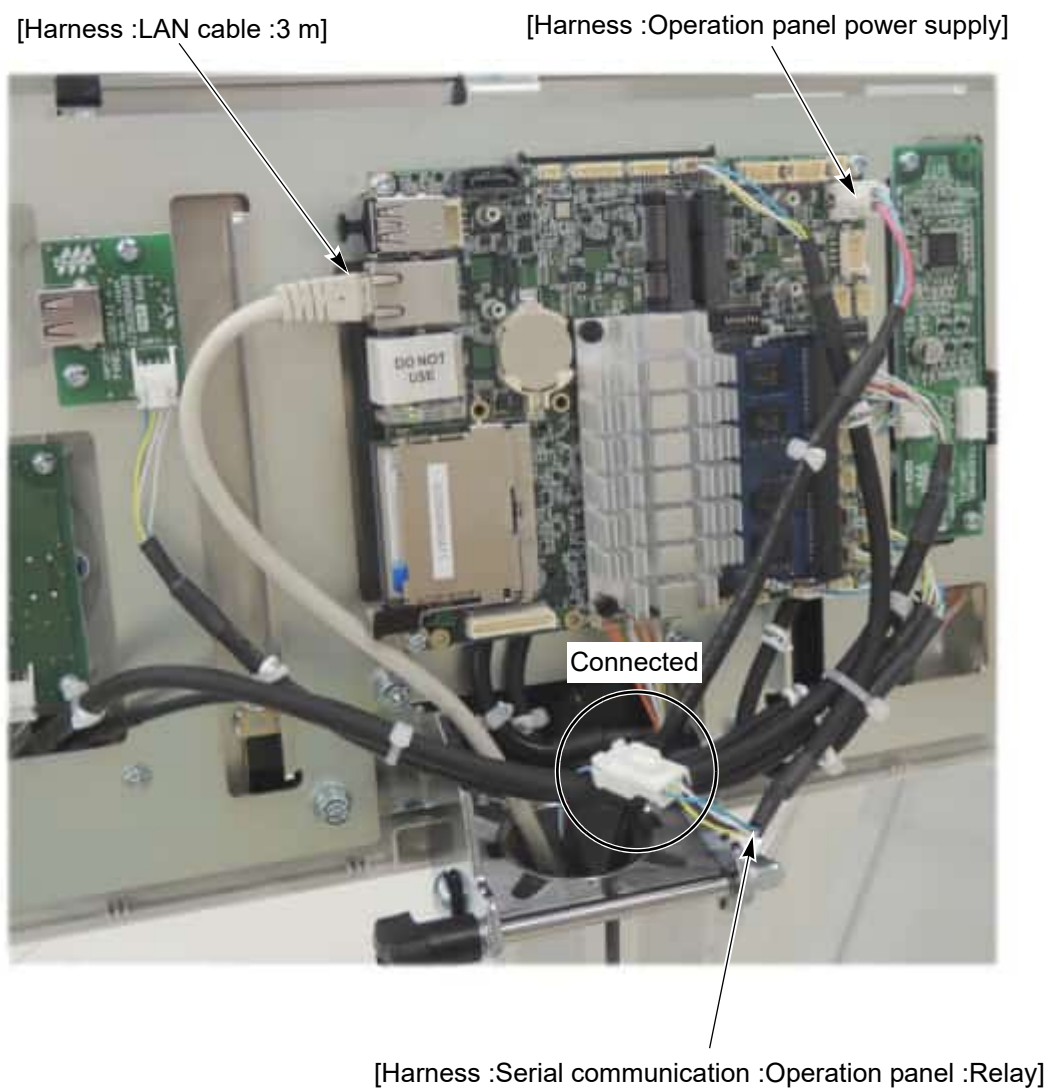

Name	Connecting destination
HARNESS :LAN CABLE :3M	CPU card [CN2701]
HARNESS :OPERATION PANEL POWER SUPPLY	CPU card [CN4101]
HARNESS :SERIAL COMMUNICATION :OPERATION PANEL :RELAY	CPU card [CN3401]

2. Table support (limited model)

Fix the table support (packed with the machine) under the table.

The table support may not be packed with the machine depending on the specification of the machine. Fixing spots of the table support also differ depending on the specification of the machine. Screw hole or nut is embedded under the table at fixing spot.

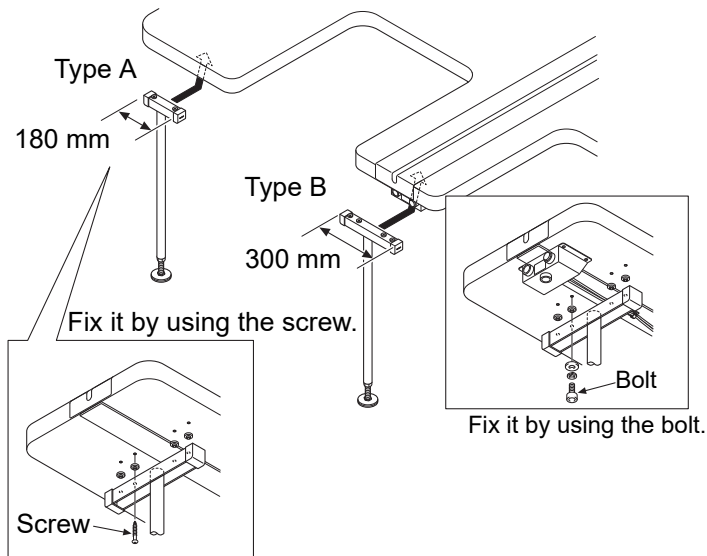

Type B



Put the table support on the floor, and adjust the height by using the adjusting bolt, then fix by using the nut.

An example of fixing spot

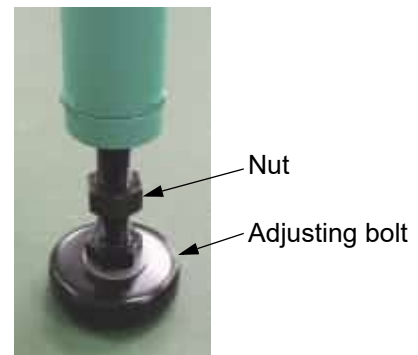
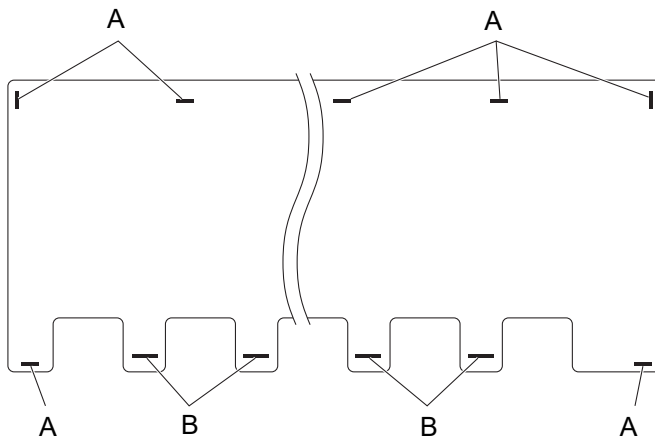

3. Thread course

3-1. HAR

Screw the thread course support bars into the square pipe and fasten the thread course with hexagon socket head cap screws.

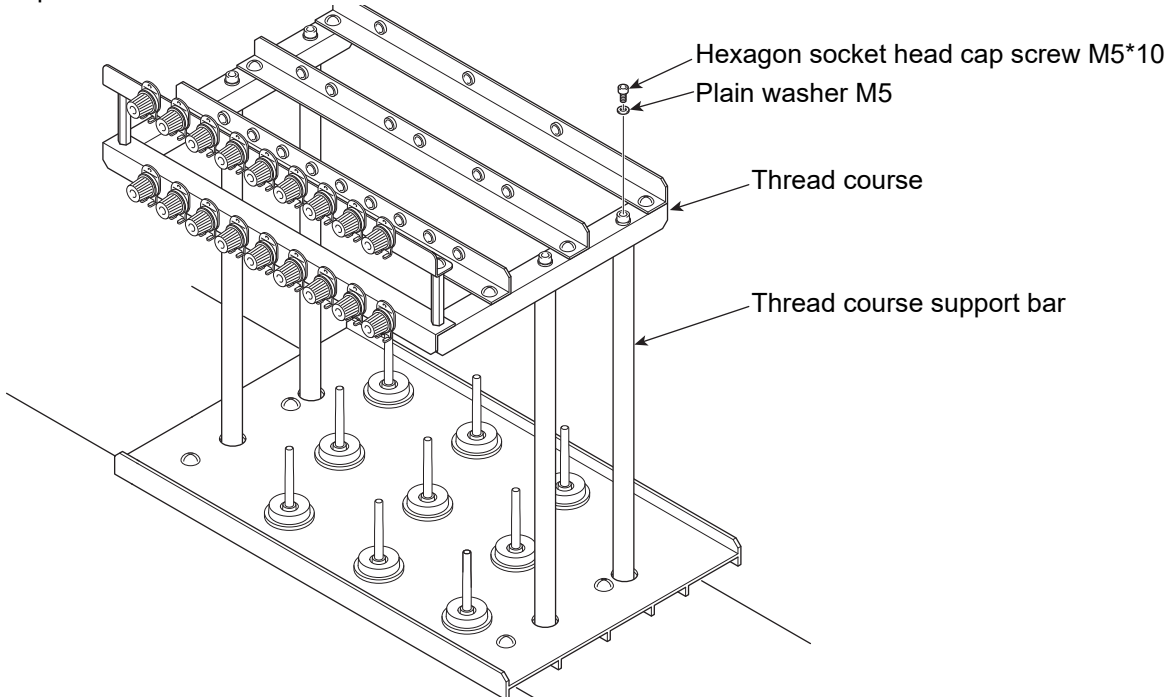

3-2. PAR

Screw the thread course support bars into the square pipe and fasten the thread course with hexagon socket head cap screws.

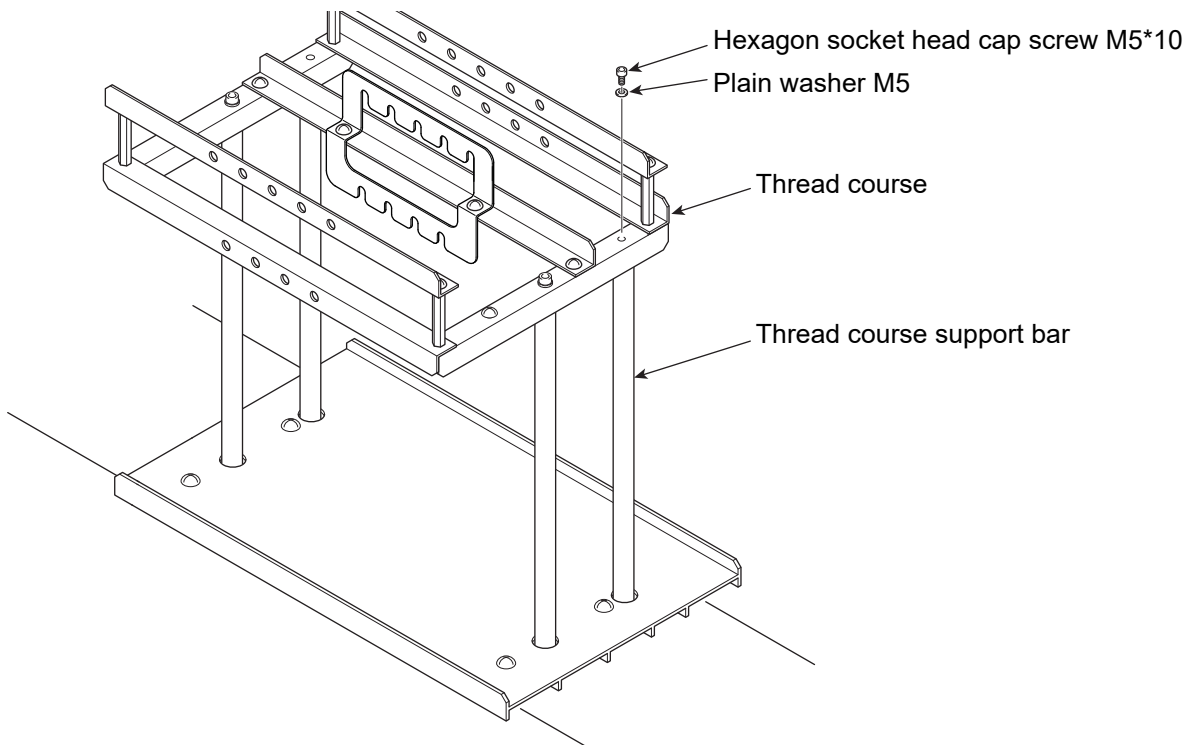

3-3. PAX (two or more pairs), PAR (two or more heads)

Screw the thread course support bars into the thread stand plate base and fasten the thread course with hexagon socket head cap screws.

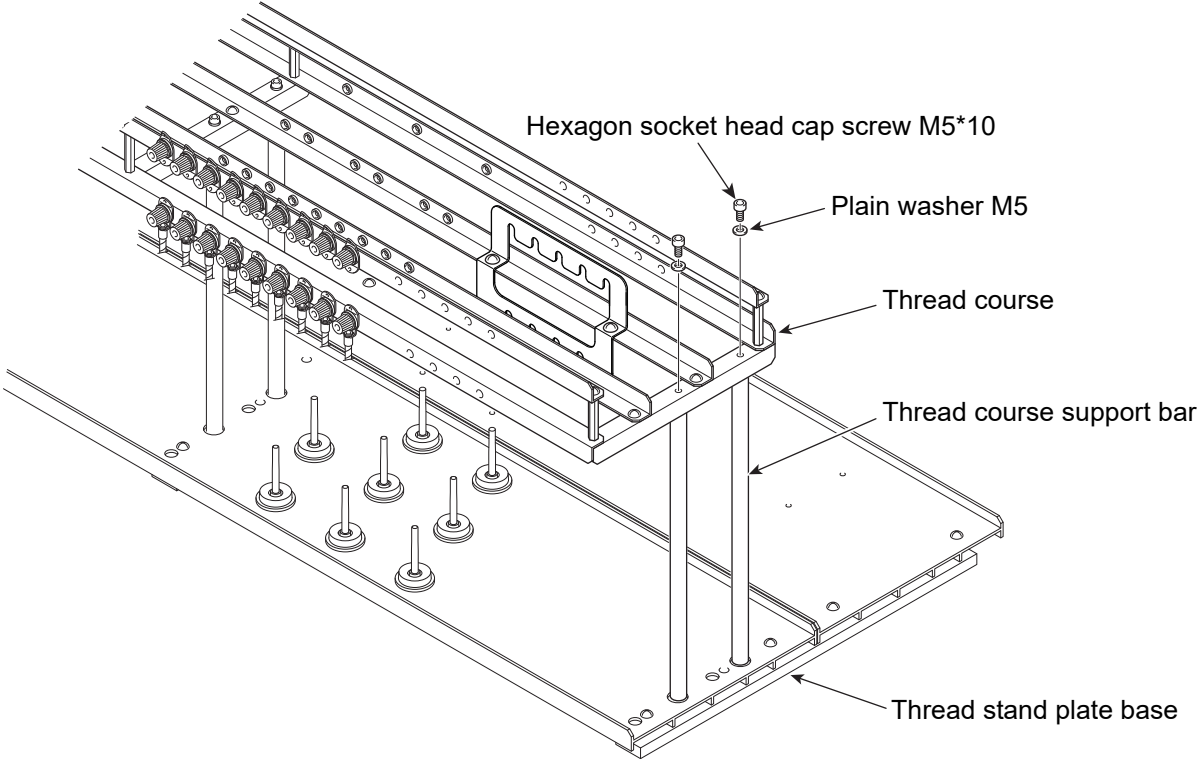

4. Nylon tube

4-1. Needle bar case

Photo after attaching nylon tube (standard spec.)

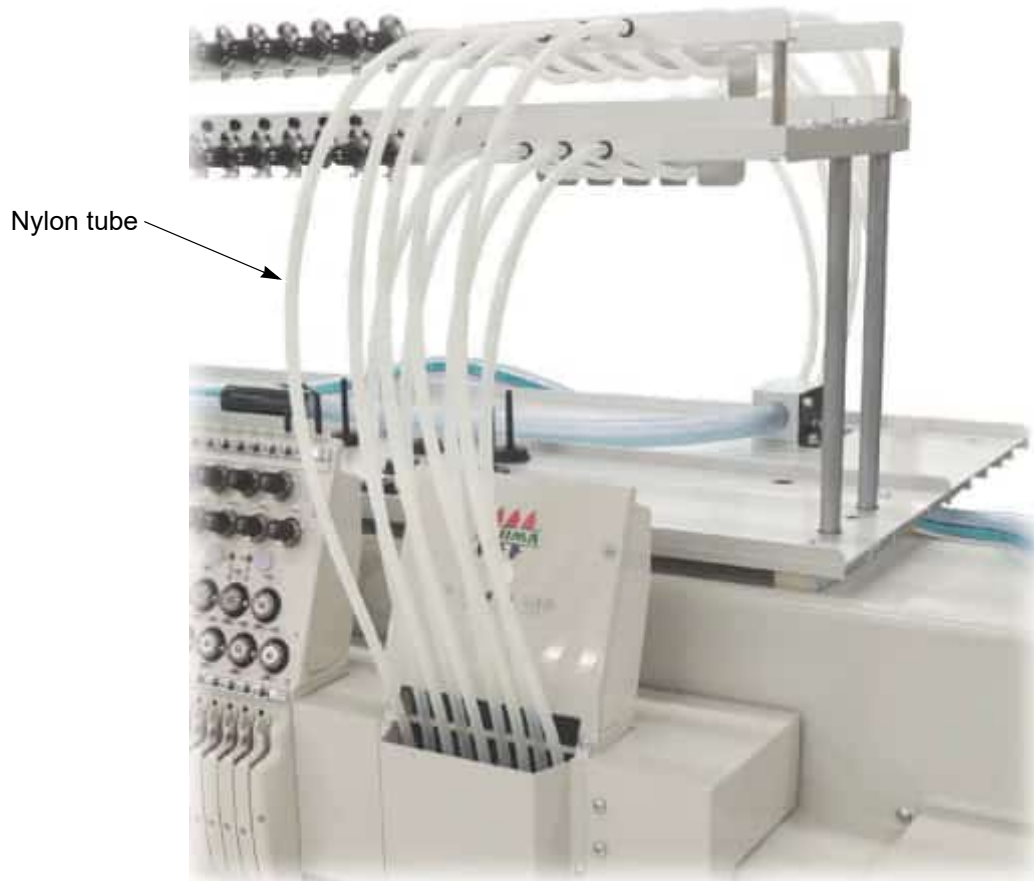

Lead the nylon tubes through the thread course according to the following steps.

The odd-numbered needle nylon tube is different from the even-numbered needle nylon tube in length.

Odd-numbered needle nylon tube

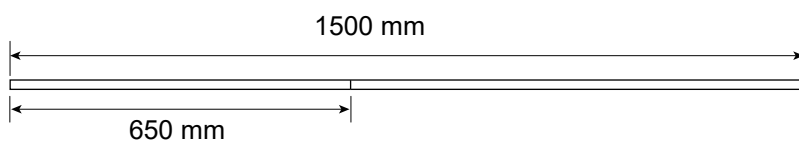

Even-numbered needle nylon tube

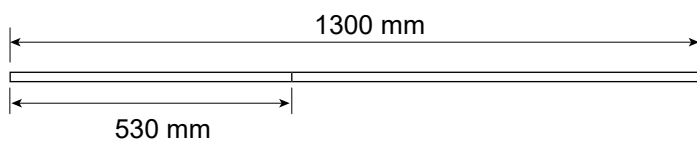

! CAUTION

! When you install the nylon tubes through the thread course, handle the tubes with care to prevent them from breakage.

- (1) Lead the odd-numbered needle nylon tubes through the front upper side of the thread course, then through the notch on the upper side of the guide tube, and finally through the rear upper side of the thread course. Lead the even-numbered needle nylon tubes through the front lower side of the thread course, then through the notch on the lower side of the guide tube, and finally through the rear lower side of the thread course.

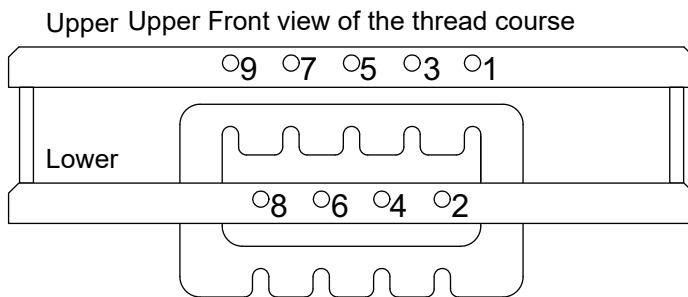

The numbers in the figure at left are the needle bar numbers.

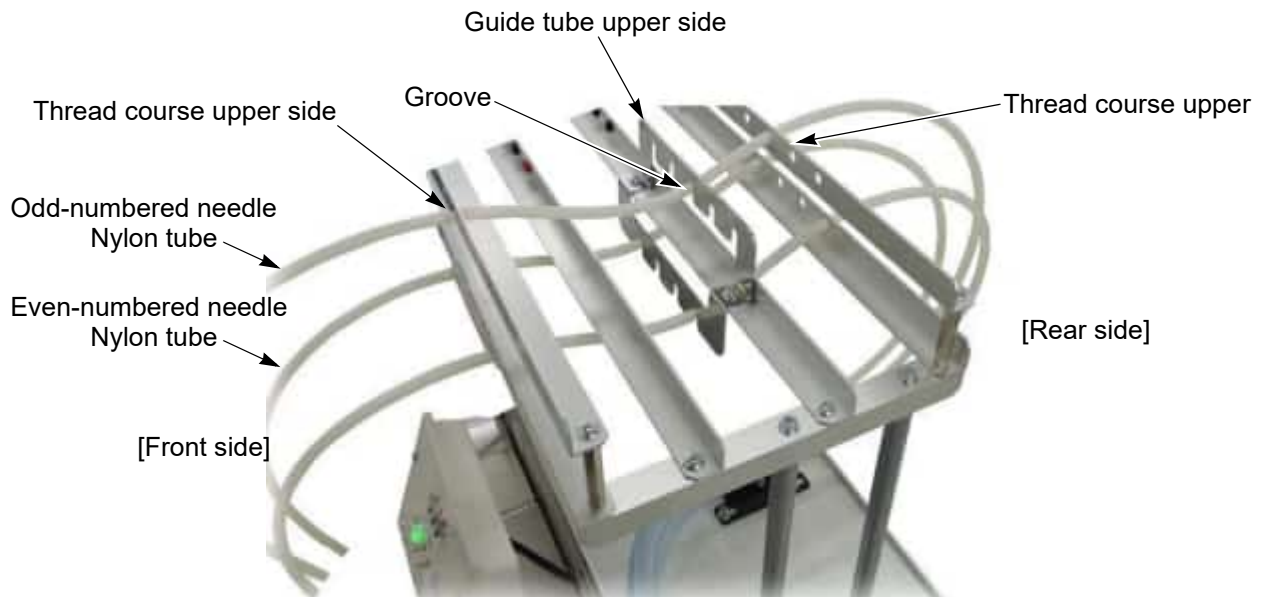

- (2) Lead the nylon tubes through O-rings and fix the O-rings at the positions where the lengths of the nylon tubes become as shown in the figure below.

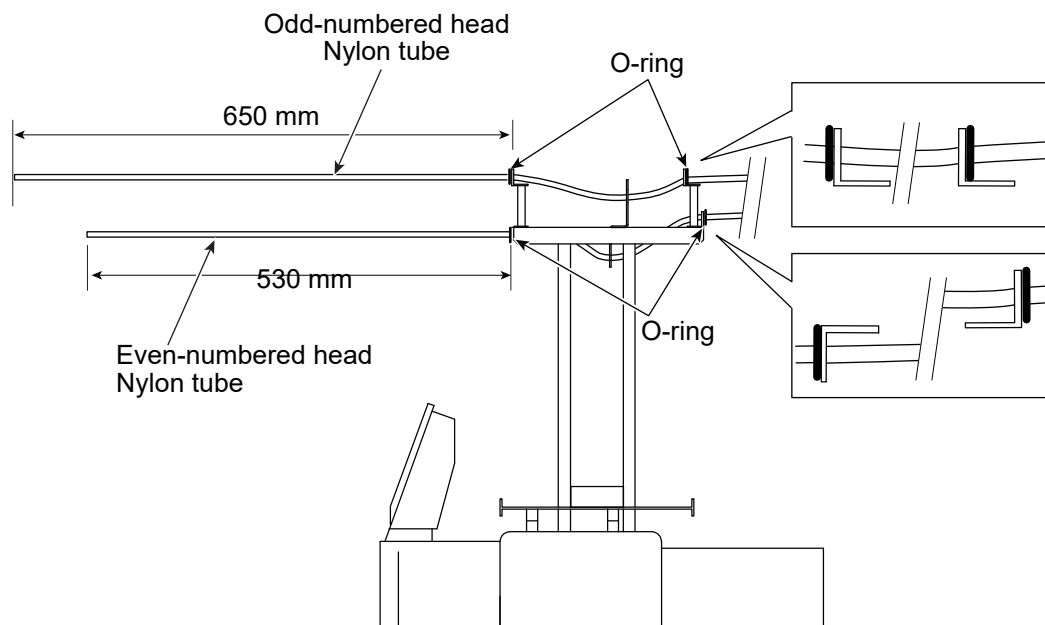

- (3) Remove screws and detach the upper front cover.

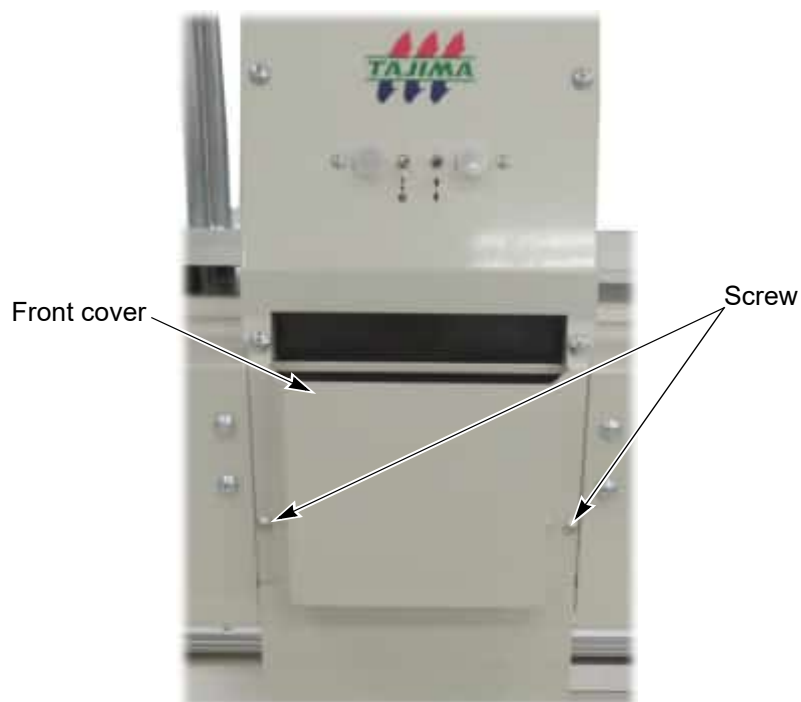

(4) Attach the nylon tubes to the joint tubes while holding each needle clamps by left hand (Figure A).

! CAUTION

- ! To attach the nylon tube to the joint tube, hold the needle clamp by left hand fingers. (Photo A)
Working while holding the perforator needle by your fingers could injure you.
- ! Operating the machine with nylon tubes crossed would cause the nylon tubes to come off.

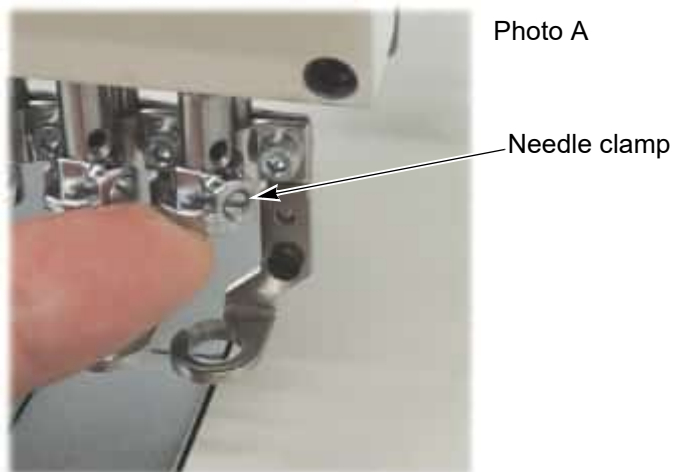
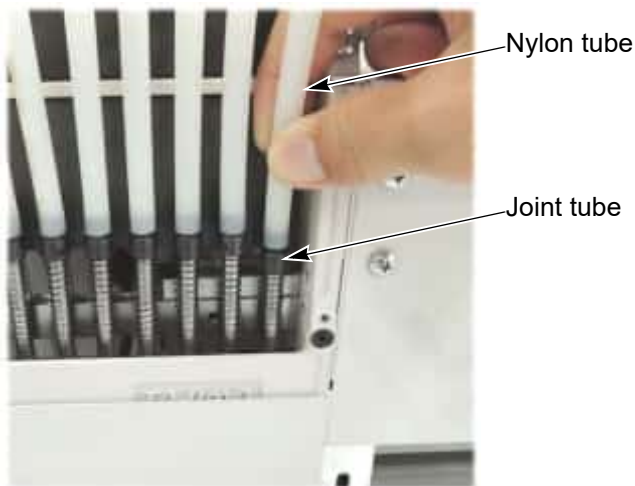

(5) Install the upper front cover.

4-2. Manifold cover (standard spec.)

- (1) Insert the nylon tubes for the second, fifth, and eighth needles into the holes in the manifold cover so that the nylon tubes do not cross each other.

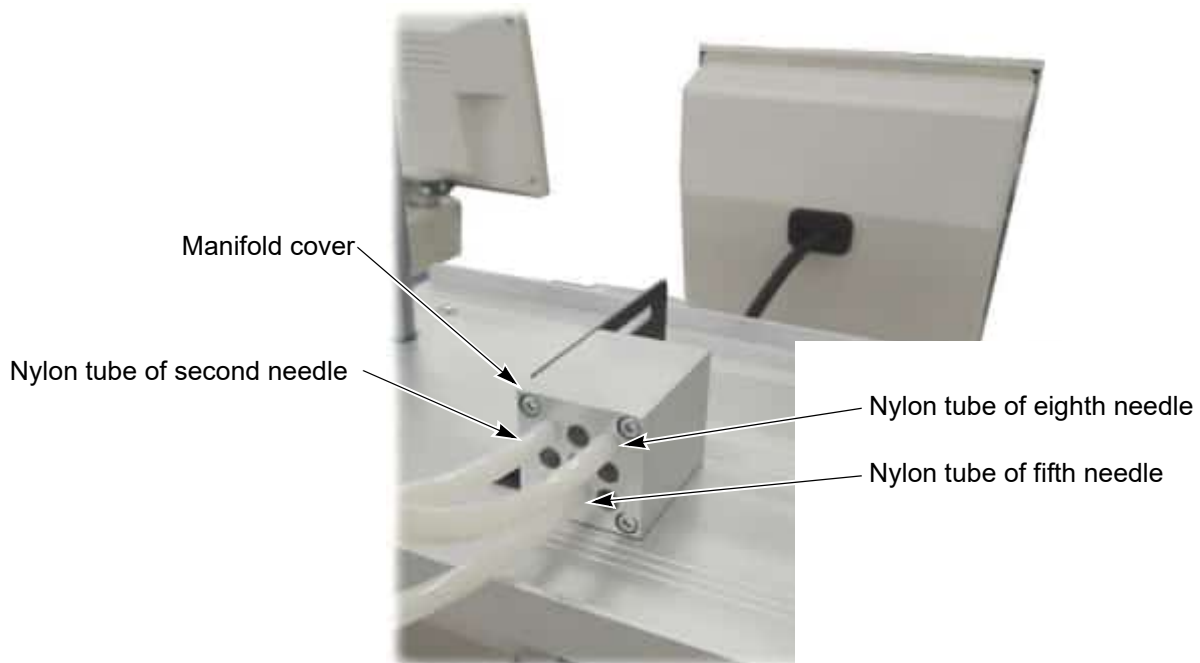

Cross section drawing

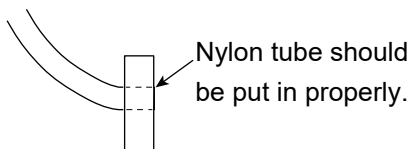

Bad example



Nylon tube should not be protruded.

- (2) Insert each tube end into opened hole of the manifold cover.

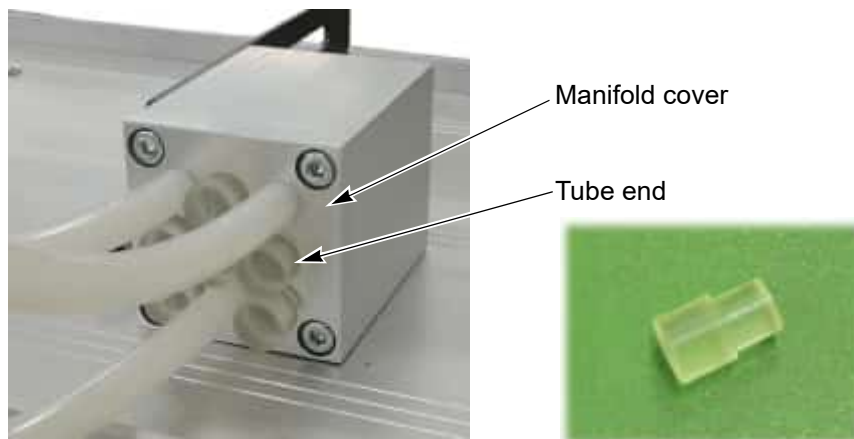

5. Synchronized vacuum system (option)

5-1. Synchronized vacuum system

- (1) Insert the nylon tubes for all the needles into the holes in the revolver base so that they do not crosseach other. Each insertion hole is specific to each needle bar number.

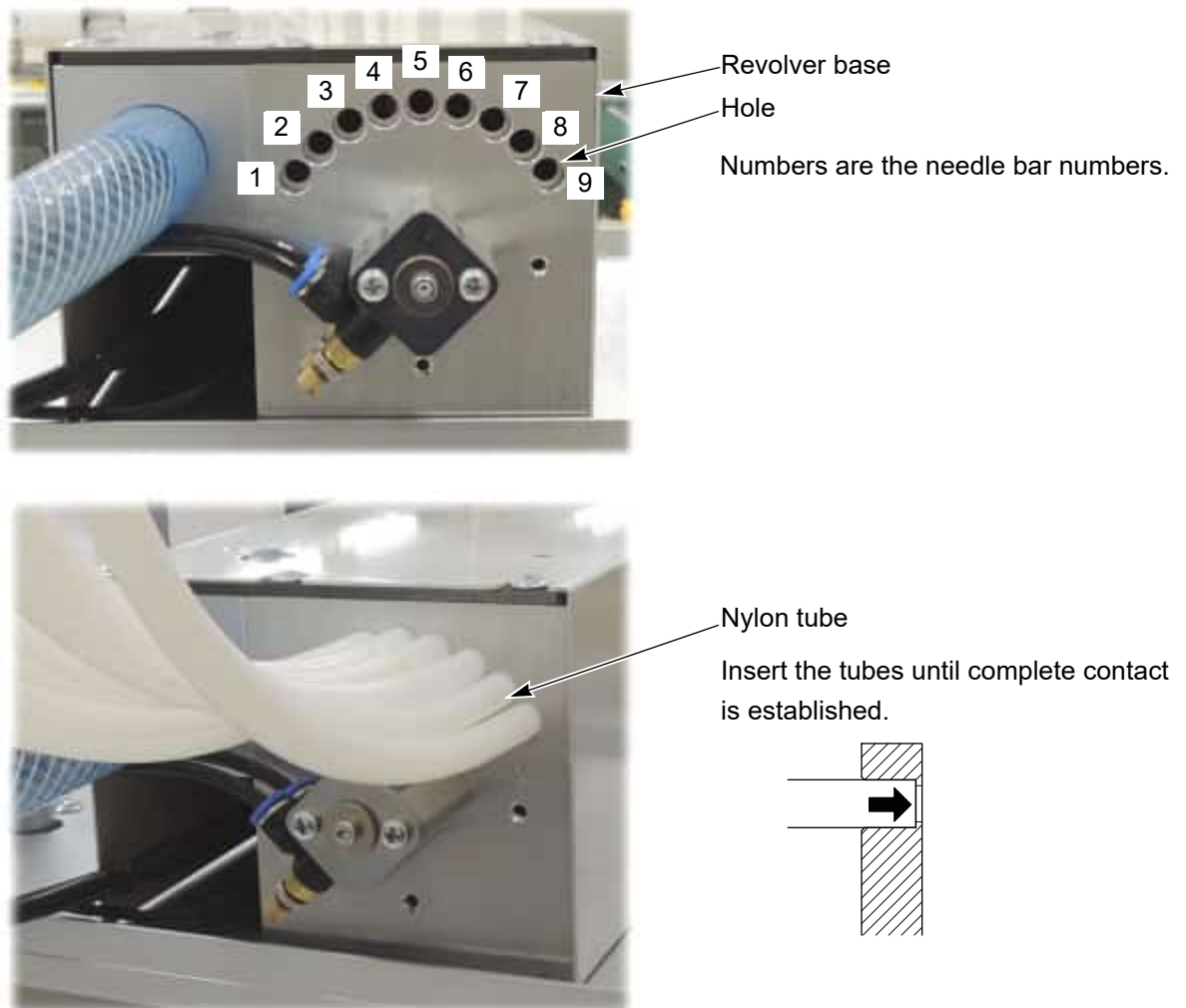

5-2. Extension device controller

- (1) Remove the connector cover of the extension device controller and connect the harness (5 pieces) to the connectors (1 to 5).

Extension device controller

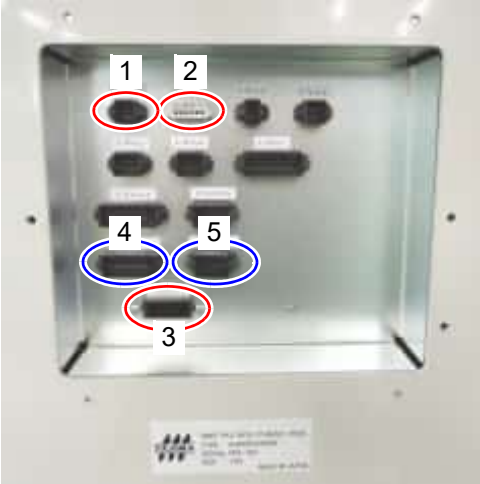

Connector

- 1, 2, 3: Always connect when the optional device is equipped
4, 5: Synchronized vacuum system

- (2) Install the box holder to the frame member with the hexagon socket head cap screw. Install the extension device controller to the box holder (front side and back side) with the hexagon socket head cap screw and the holder pins.

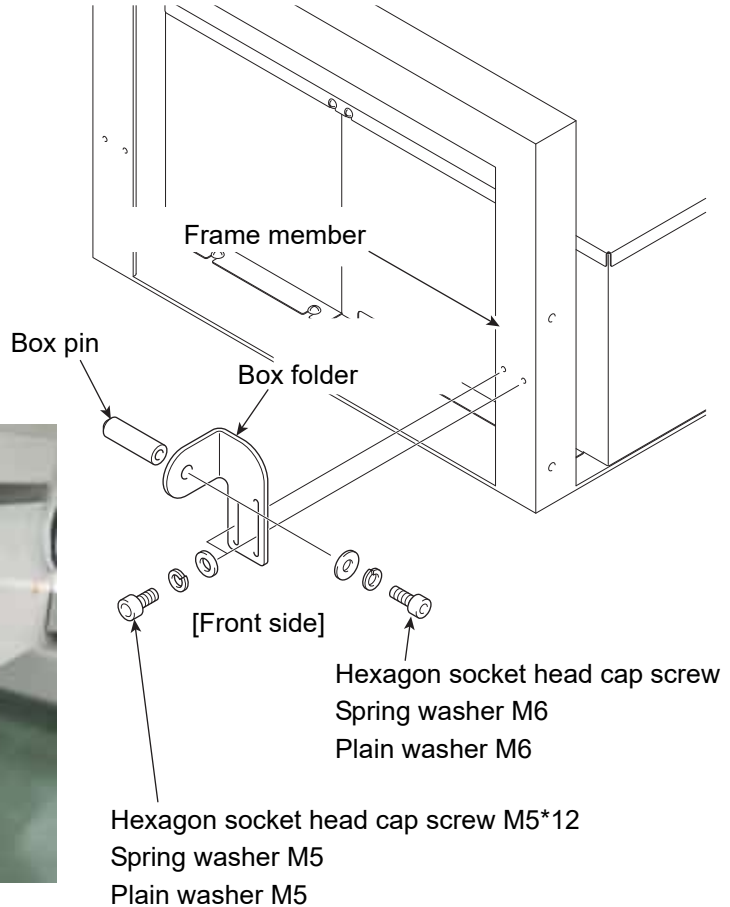
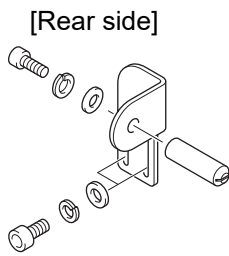

Extension device controller

5-3. Parameter setting confirmation

The following parameter settings are required for the synchronized vacuum system to operate. The table below shows these settings for reference purpose only since they are set when shipped from the factory.

Parameter	Setting value	Remarks
14 External Device I/F	Yes	P7-77 Optional Device (hardware)-P2
17 Extension Device Controller	Yes	
1 5 V external input	A5 : Extension Controller error alert	P7-79 external device I/F
4 24 V External output	B2: Main shaft timing A B3: Main shaft timing Z	
3 Synchronized Vacuum System	Yes	P7-80 Extension Device Controller Setting

6. Auto. PP Tape Feeder (option)

6-1. Tape feed unit

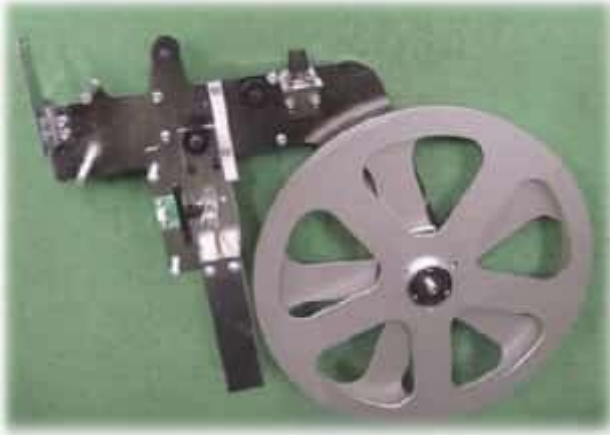

Tape feed unit

- (1) The table support may not be packed with the machine depending on the specification of the machine. Fixing spots of the table support also differ depending on the specification of the machine. Screw hole or nut is embedded under the table at fixing spot.

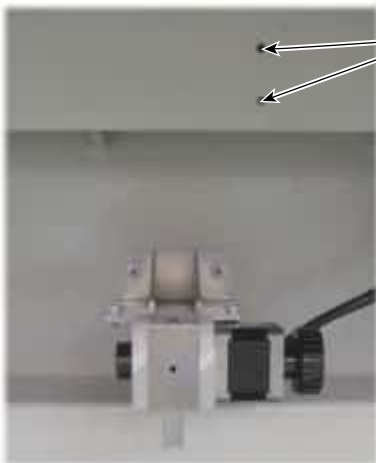

Screw hole

Hexagon socket head cap screw M5*20
Spring washer
Plain washers



Tape feed unit

(2) Adjust the left-right position of the tape feed unit so that the flat pulley is aligned with the center of the tape inlet of the perforator base and fasten it with hexagon socket head cap screws M5*20.

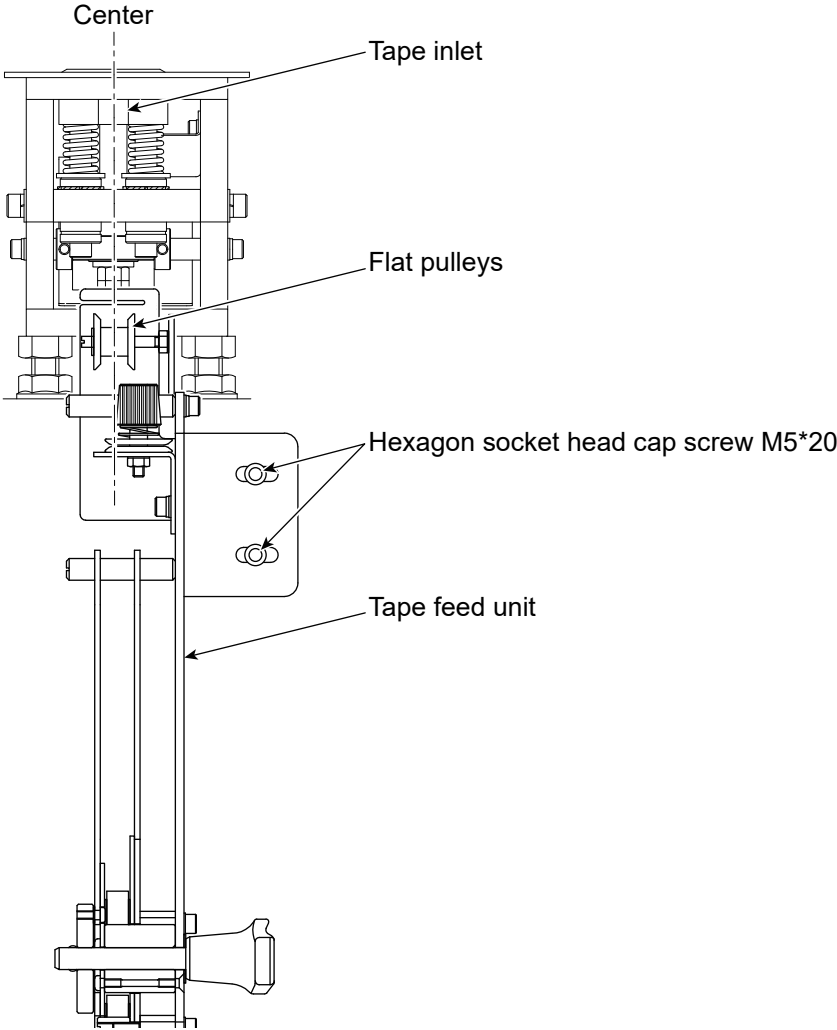

(3) Connect the harness to the magnetic sensor B card connector.

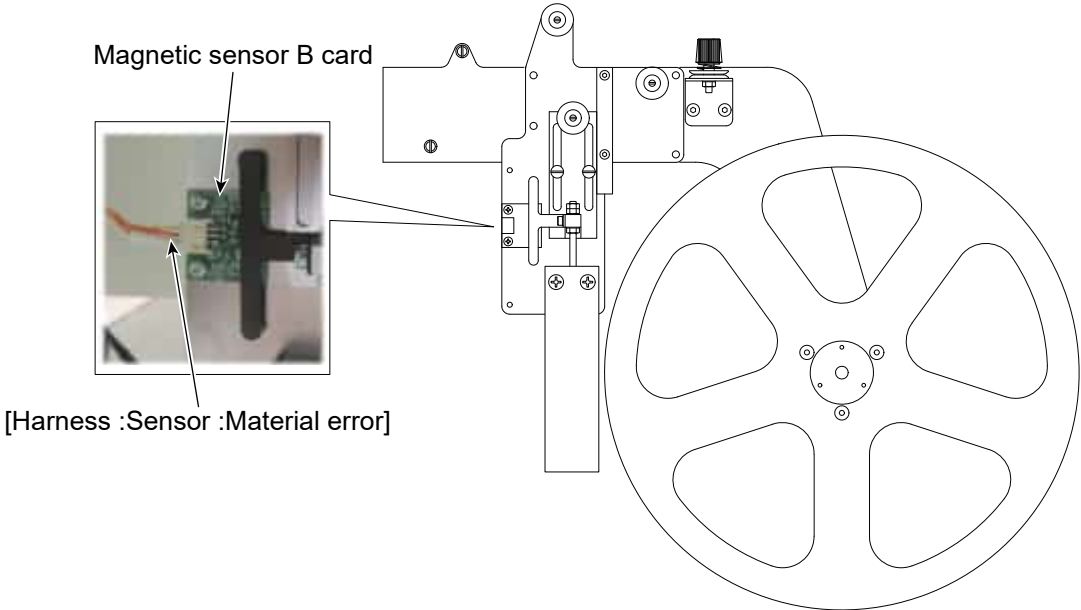

6-2. Installing PP tape

- (1) Remove resin reel B while pushing the ball lock pin button.



Plastic reel B



Ball lock pin

- (2) Install the PP tape to the plastic reel lid so that the PP tape appears to be wound counterclockwise.



Plastic reel lid

PP tape

- (3)** Fit the ball lock pin into the center hole in the plastic reel B while pushing the ball lock pin button. Securely couple the plastic reel B with the plastic reel A by turning the plastic reel B and then release the button.

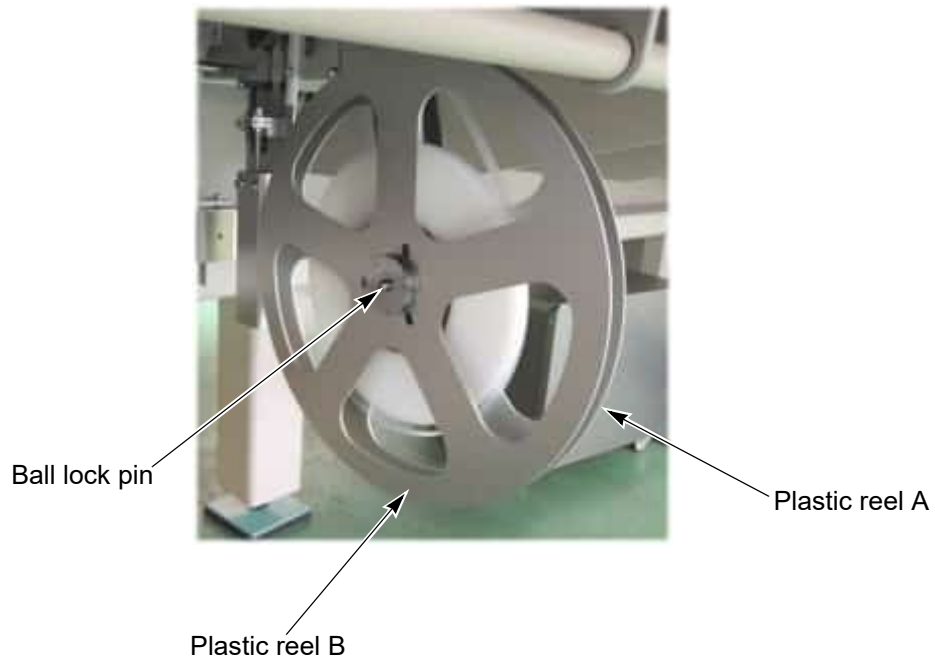

(4) As shown in the photo, lead the PP tape through guides A, B, C in this order.

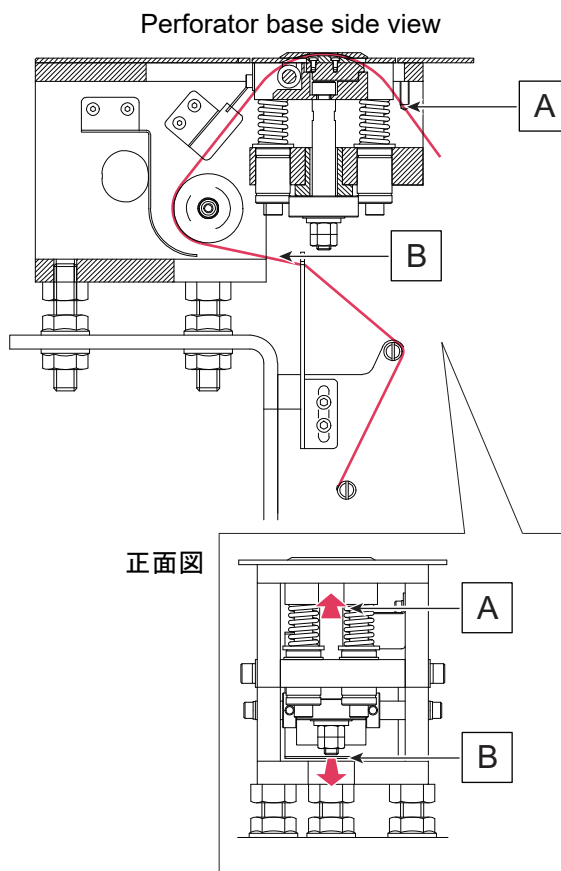
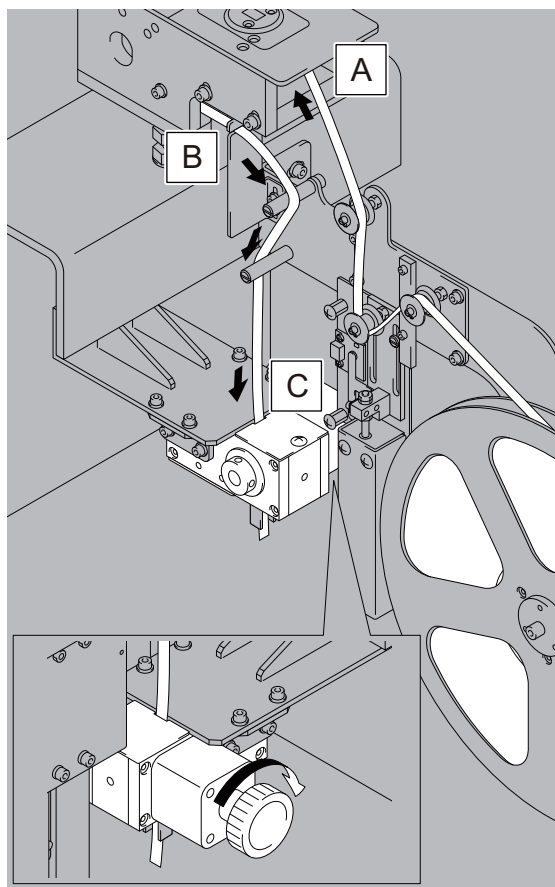

Push the PP tape into A.

The PP tape comes out of C.

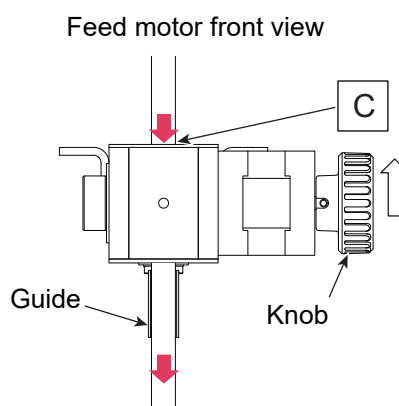

Insert the PP tape into C. Turn the knob in the arrow direction until the PP tape is drawn several centimeters out of the guide.

6-3. Extension device controller

- (1) Remove the connector cover of the extension device controller and connect the harness (5 pieces) to the connectors (1 to 5).

Extension device controller

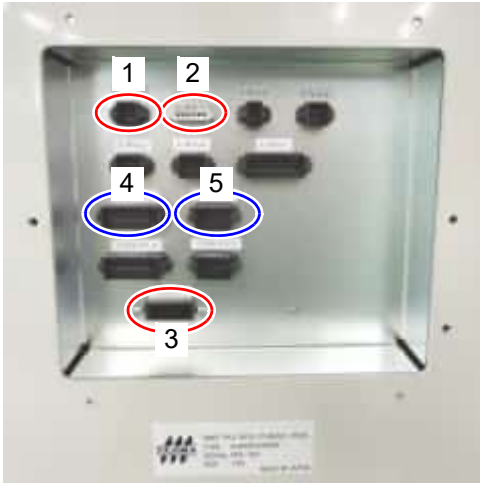

Connector

- 1, 2, 3: Always connect when the optional device is equipped
4, 5: Auto. PP Tape Feeder

- (2) Install the box holder to the frame member with the hexagon socket head cap screw. Install the extension device controller to the box holder (front side and back side) with the hexagon socket head cap screw and the holder pins.

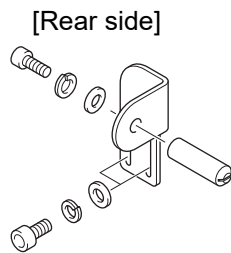

Extension device controller

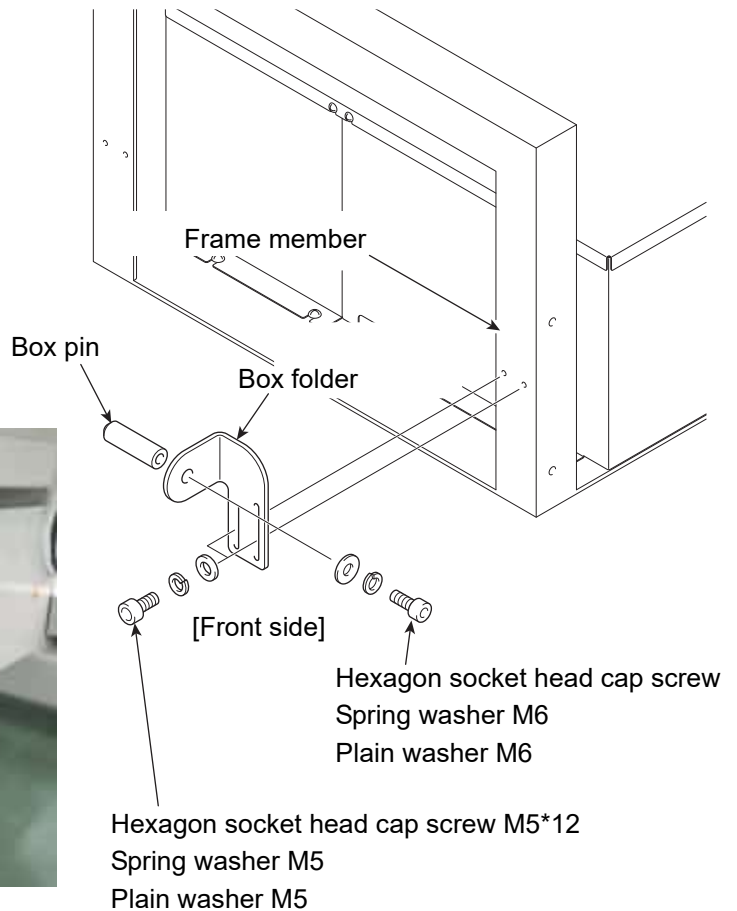

6-4. Parameter setting confirmation

The following parameter settings are required for the auto. PP tape feeder to operate. The table below shows these settings for reference purpose only since they are set when shipped from the factory (except for the tape feed amount).

Parameter	Setting value	Remarks
14 External Device I/F	Yes	P7-77 Optional Device (hardware)-P2
17 Extension Device Controller	Yes	
1 5 V external input	A5 : Extension Controller error alert	P7-79 external device I/F
4 24 V external output	B2: Main shaft timing A B3: Main shaft timing Z	
2 Auto. PP Tape Feeder	Yes	P7-80 Extension Device Controller Setting
Tape feed amount	[Applicable needle bars] ^[1] All needles or specified needle [Tape feed amount] 0.1 ~ 3.0 (mm)	P7-80 Extension Device Controller setting - 2 Auto. PP Tape Feeder

[1]Change [applicable needle bars] and [tape feed amount] as needed.

7. Hose and Vacuum Device

7-1. Hose

- (1) For a single head machine, insert the hose into the manifold base. If the hose connection is loose, wind tape around the hose as shown in the photo. For a multi-head machine, this step is not necessary since the hose is already installed to the manifold.



Manifold base
Hose

Cross section drawing

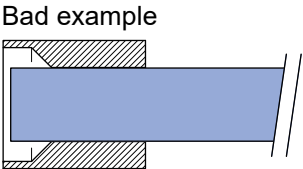
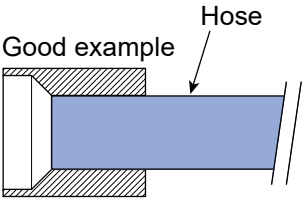

The hose should not be protruded.

(2) Fix the hose on the top of the square pipe.

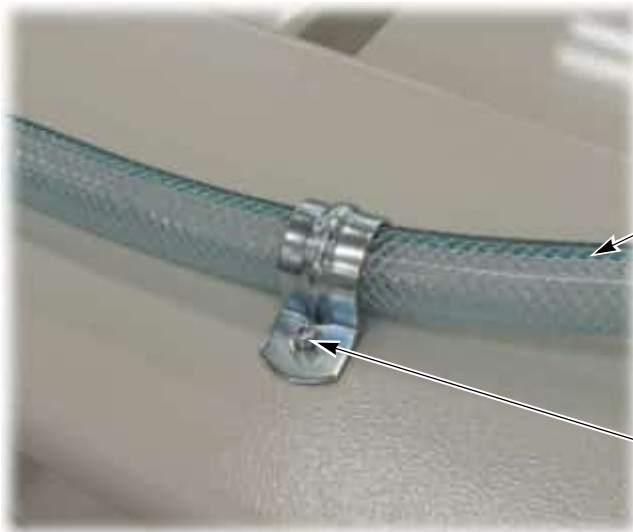

Hose

Hexagon socket head cap screw M4*8
Spring washer M4
Plain washer M4



When using the dust catcher, cut or extend the end of the hose as necessary to connect.

7-2. Vacuum device (PAX, PAR)

This machine needs the vacuum device to clean up the trash after perforating at P head.

This machine supports up to twenty perforator needles at the maximum.

There are following two types of vacuuming source. Prepare the device of the specifications or higher shown in the list below.

(1) Air type (mainly air compressor) (option)

Specifications	Remarks
Pressure: 0.5 (MPa) / Flow rate: 340 (L/min) or more Dynamic pressure: 0.4 or more / Static pressure: 0.7 or less	<ol style="list-style-type: none"> 1. It will work together with start or stop of P head. 2. Since the trash after perforating will be discharged, put the hose into the jute bag, etc.

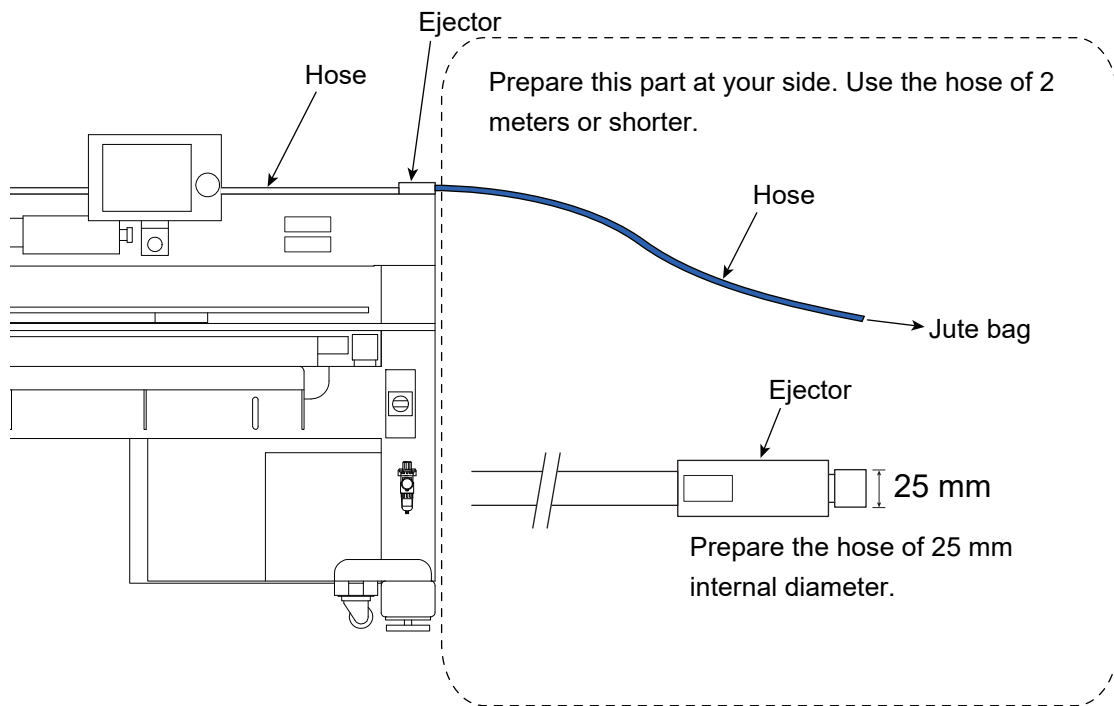

(2) Electric motor-driven type (mainly dust catcher or vacuum cleaner)

! CAUTION

! The dust catcher or the vacuum cleaner will not work together with start or stop of P head. Therefore, turn ON the power of the device when turning ON the power of the machine. Otherwise, trash after perforating is piled up inside the perforator needle, the needle bar or the nylon tube.

Specifications	Remarks
Static pressure: 18 (kPa) / Air volume: 2 (m ³ /min) or more	It will not work together with start or stop of P head. Therefore, turn ON the power of the device when turning ON the power of the machine.

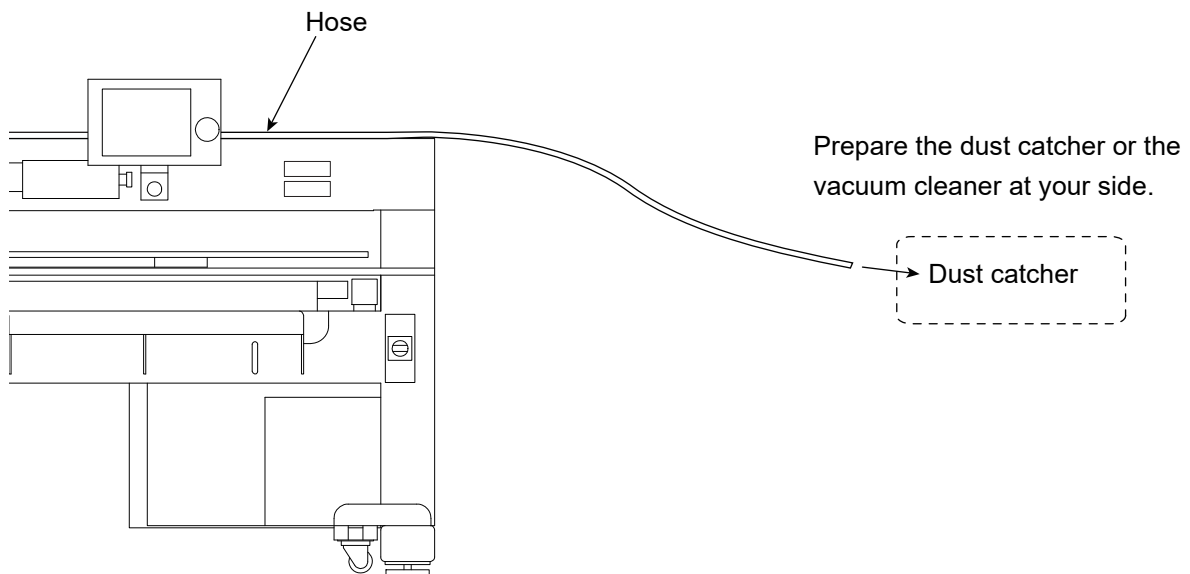

Chapter 3 Connection of power cord

1. Important safety instructions

DANGER

-  When you connect the power cord, be sure to turn "OFF" the primary power supply. There could be a danger of electric shock, burning or death. In addition, check if the voltage of the voltage indicating label that is attached to the power cord fits to voltage spec. on your side, and then connect the power cord to the primary power supply.

An example of connecting power cord

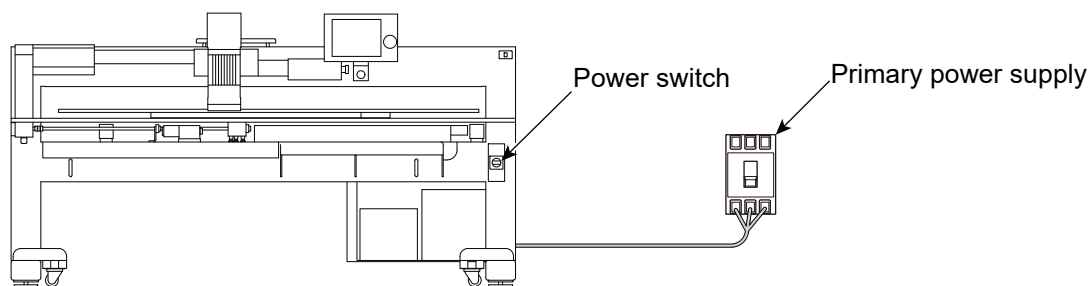



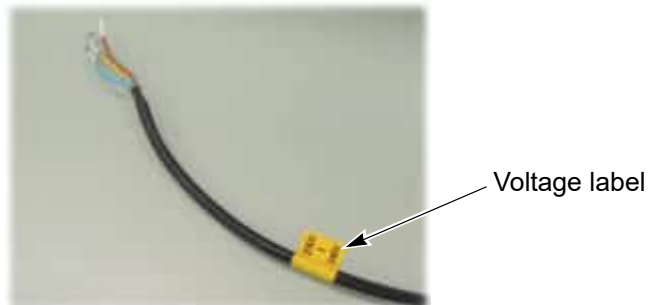

The power cord differs depending on the specification.





-  If the machine needs to be connected to an external power supply, the power supply cable connection must be done only by the service personnel assigned and trained by TAJIMA or qualified technician.

WARNING



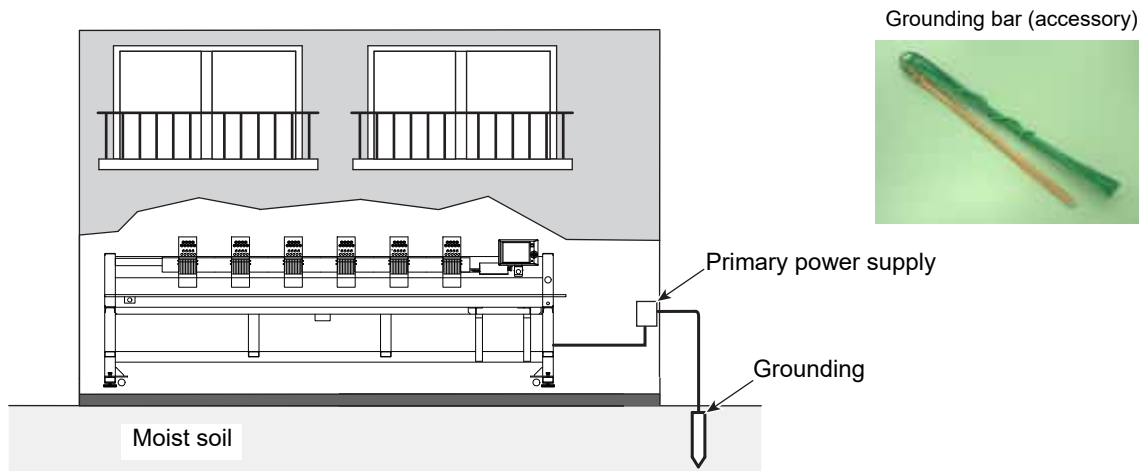

-  When supplying the power, conform to excess voltage category "III".
-  Connect the machine to the power supply line that is not connected to machines subject to large load fluctuation such as elevators and presses so that the machine can operate in stable conditions.
-  Check if power voltage is enough for operating the machine by using a multimeter.
Voltage: Within $\pm 10\%$ of the rated voltage
-  The power supply cable must be laid out of the operator's moving area so that the operator does not step on the cable.

WARNING

-  Insert the power cable plug fully. If a metallic part etc. touches a blade in the plug, it may cause fire and/or electric shock.
-  Since there is the danger of electric shock due to leak current, be sure to connect the grounding wire. In addition, degree of grounding should be type D or higher (grounding resistance 100 ohms or less).



CAUTION

-  In addition to full-time leak current, leak electric current generated by harmonics and surge flows in the power cable of the machine. For this reason, if selection and installation of breaker of leak current and leak current relay used for the factory are not correct, malfunctioning of the machine may occur.
Regarding connection of power cord, observe the following items.
-  Use a breaker of electric current leakage and leak current relay for which measures are taken against harmonics and surge. If such a breaker and a relay are not available, select conventional breaker and relay with sufficient leak current capacity to absorb leak current caused by harmonics and surge. (In this case, constant leak current must be controlled satisfactorily.)
-  Regarding capacity of electric current leakage for breaker of electric current leakage and leak current relay per machine, please consult your local TAJIMA distributor.
-  For actual product names of breaker of electric current leakage and leak current relay for which measures are taken against harmonics and surge, please consult your local TAJIMA distributor or electric engineers.
-  To prevent the machine from property damages for connecting power cord, one machine should be connected to one no fuse breaker. Property damages include a drop of output of the main shaft motor, etc., stop position error and color change error caused by the stop position error, design displacement, etc.

Chapter 4 Operation panel settings

1. Parameter setting

A parameter list is attached to the back of the operation panel. Check setting values. At this moment, check also version of the software.



2. Absolute origin search

CAUTION

 When performing this operation, do not put your hands, etc. on the machine table. You could be injured by moving frame.

This function makes the machine memorize the absolute origin. Perform this operation under the following conditions.

- (1) When setting up the machine
- (2) When installing software
- (3) When the frame might be moved with the power turned OFF

[How to operate]

1. Icon F

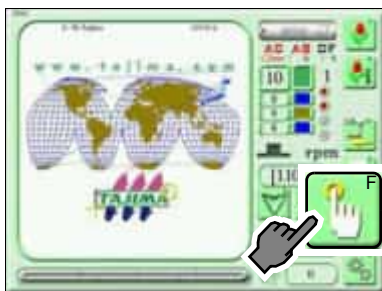

2. Icon O

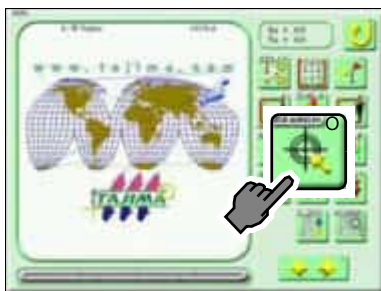

3. Yes (Completed)

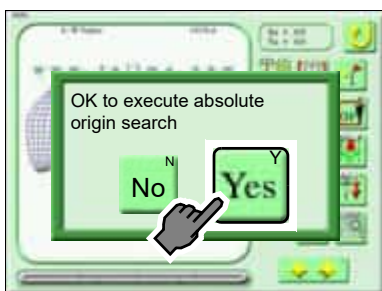

After Frame Travel, the frame will return to the previous position.

Chapter 5 Level adjustment

1. Level adjustment

Adjust level by using a level gauge in the state of no slant or contortion of the machine. There are four spots for measuring.

Level gauge



Use the level gauge of 60 cm length or longer and sensitivity within 0.5 mm/m.

Magnet holder



The magnet holder is used to adjust level in front/rear direction.

(1) Level adjustment in right and left direction

Place the level gauge on the square pipe.

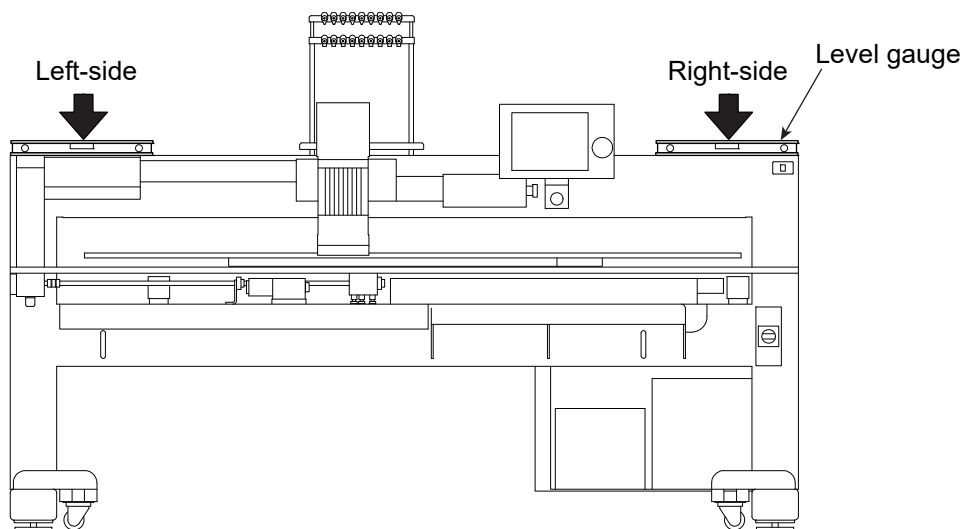

(2) Level adjustment in front and rear direction

Attach the magnet holder so that the corner of the magnet holder comes to the center of the punching mark. Place the level gauge on the magnet holder.

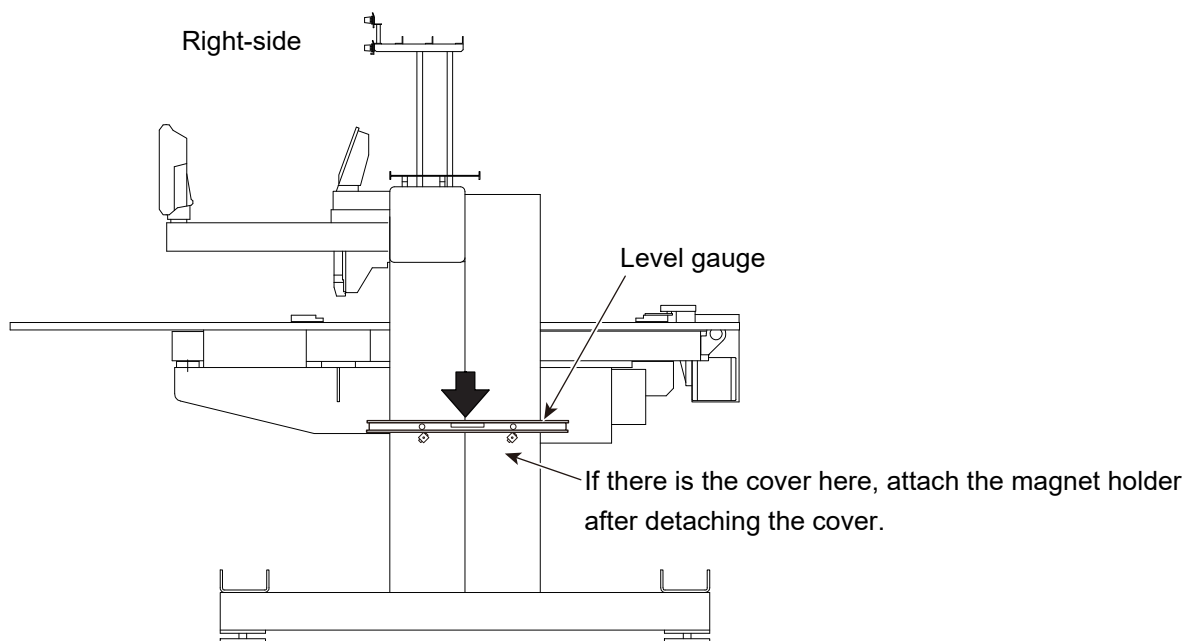
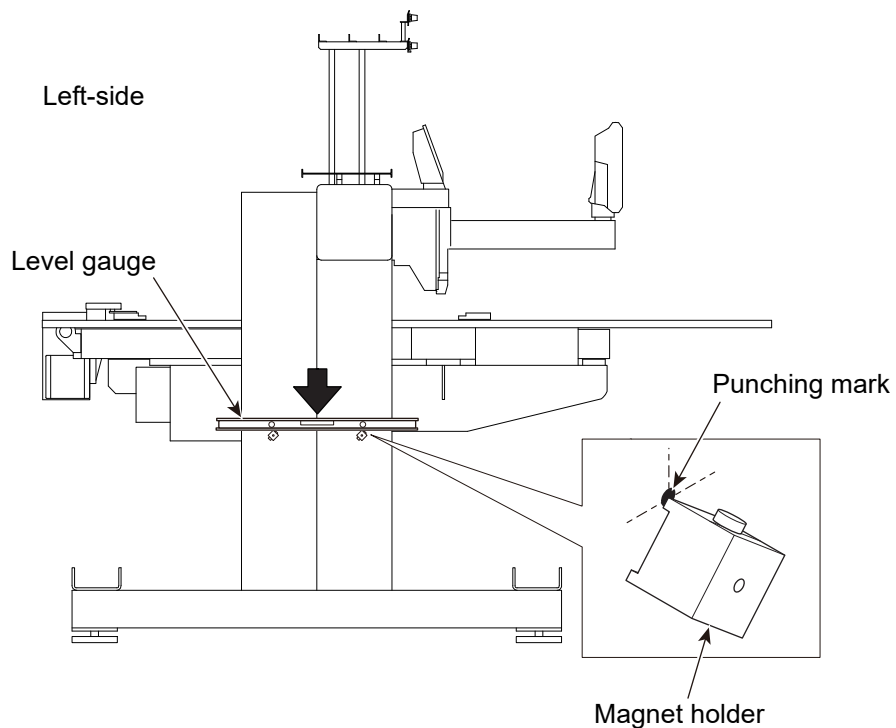

- (3) Adjust two pieces of the leveling bolt on a diagonal line while checking bubble of the level gauge, and adjust the remaining two pieces of the leveling bolt next, then tighten the nut. At this time, perform tightening so that the effectiveness (load) of four pieces of the leveling bolt becomes equal.

! CAUTION

! Fix the leveling bolt with the caster lifted up about 5 mm.

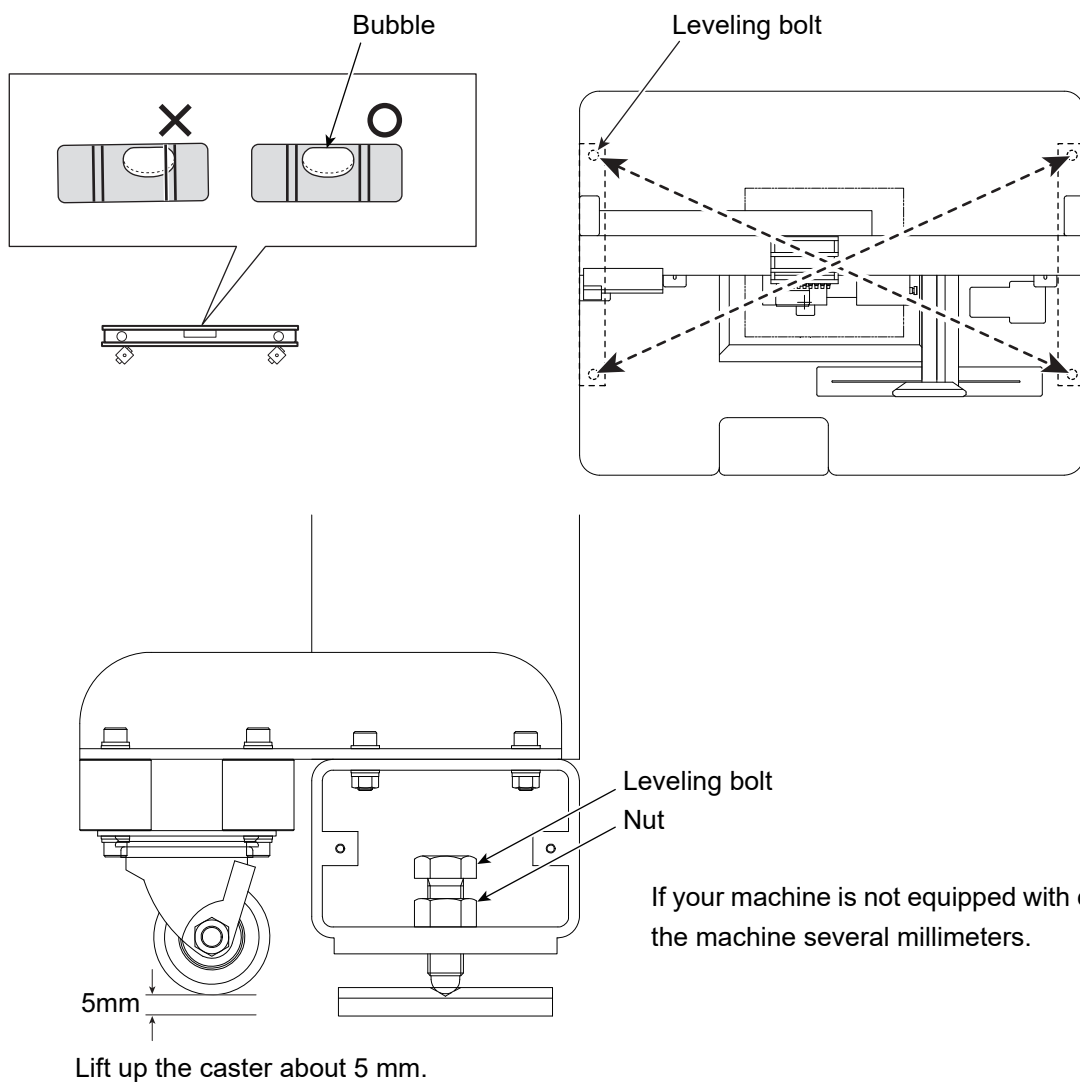

Chapter 6 Adjustments

1. All sorts of adjusting methods for H head (PAX, HAR)

1-1. H head needle location (PAX, HAR)

This working checks the first needle and the last needle of all heads.

- (1) Release "Main shaft brake". (Refer to p.38)
- (2) Lower one time the tension base right switch of the head which starts working from now. The presser foot will lower.

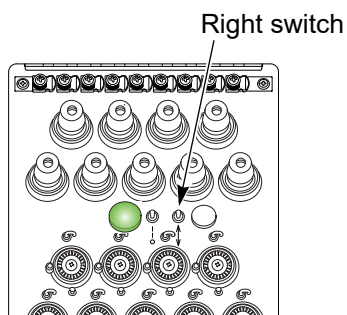

- (3) Turn the main shaft clockwise to set the main shaft angle to 193°.
- (4) Lower the needle bar to check that the needle is almost located at the center of the needle hole.

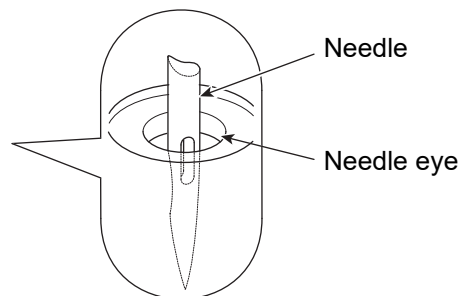

- (5) When adjustment is necessary, loosen screws (two spots at left and right), and adjust the needle location by sliding the needle bar case to left and right.
 When positions of needle location at the first needle and the last needle are misaligned, symmetrize their positions so that each needle is located the center of needle hole as much as possible.

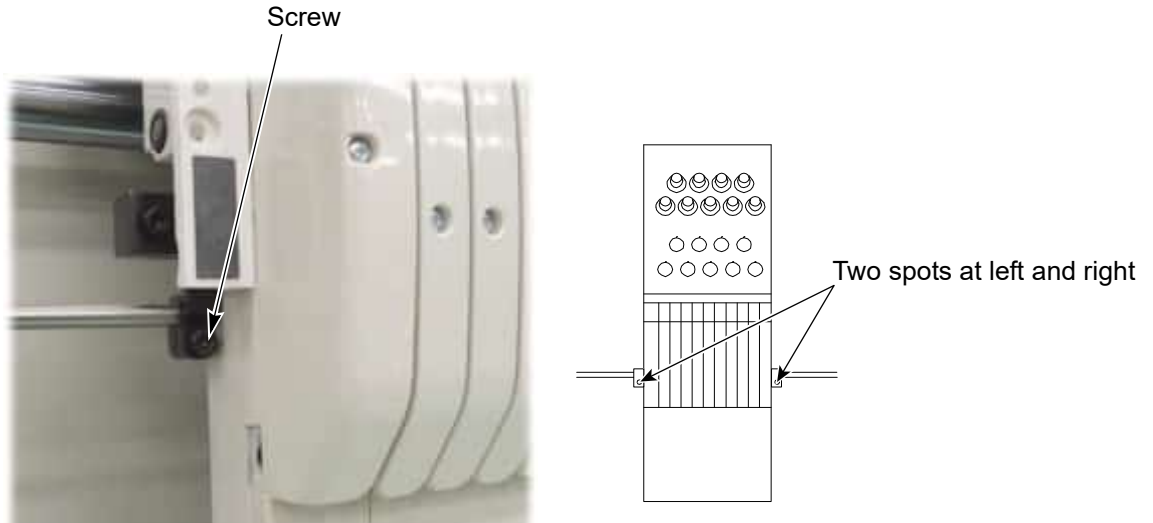

1-2. Needle bar lower dead point adjustment (Input of the password is necessary)

! CAUTION

⊘ Do not perform this adjustment in the state of loading weight on the table (something is leaning on the table). It is not possible to adjust correctly while loading.

Release "Main shaft brake" by the following procedure.

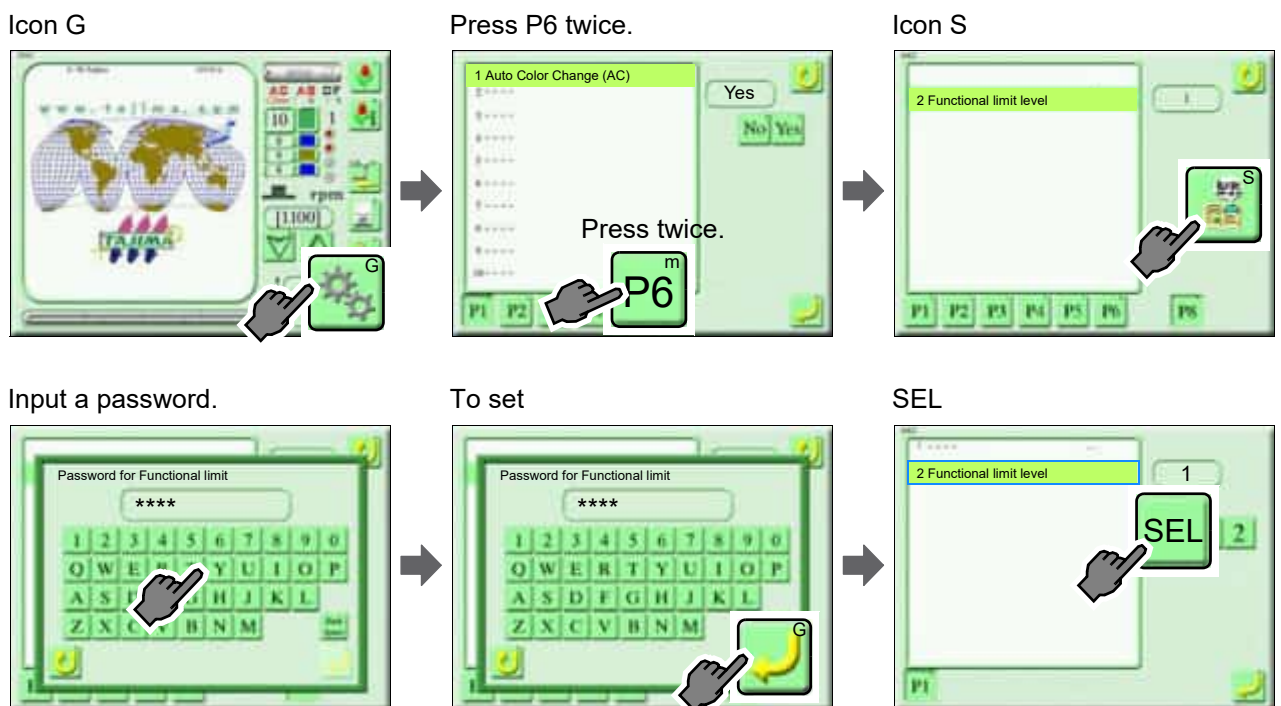

Icon T

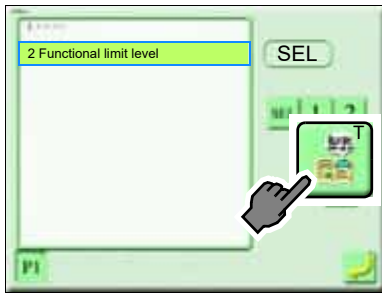

ALL Yes

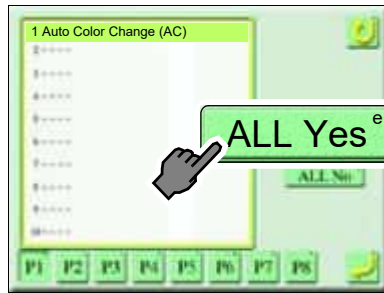

Outer frame turns yellow during setting level SEL.



To set

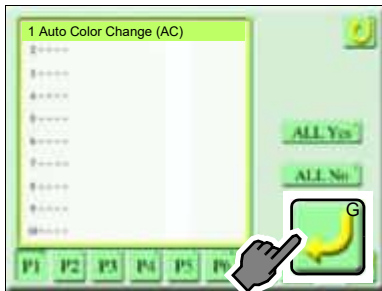

To set

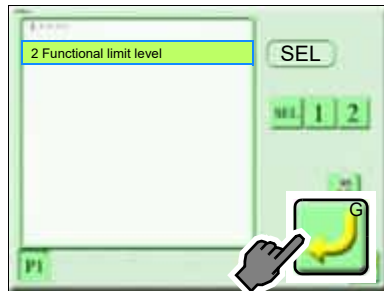

Icon A

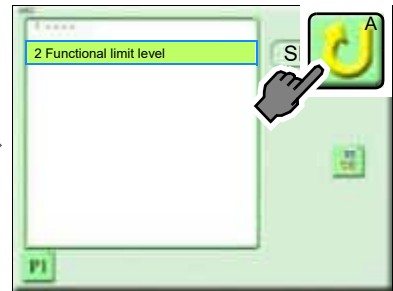

85 Machine adjustment

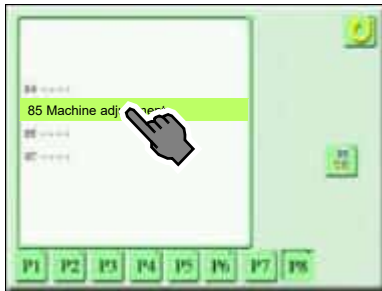

Icon T

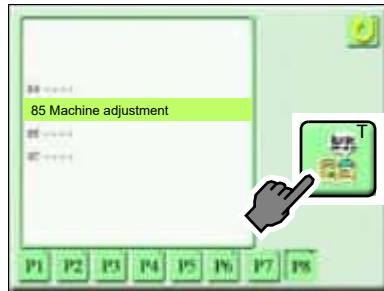

9 Main Shaft Brake

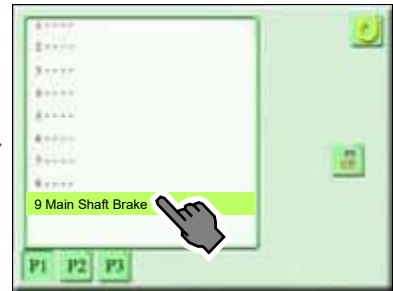

No



To set



- (1)** Remove screws 1 and detach the middle thread guide set. Remove screws 2 and detach the face cover.

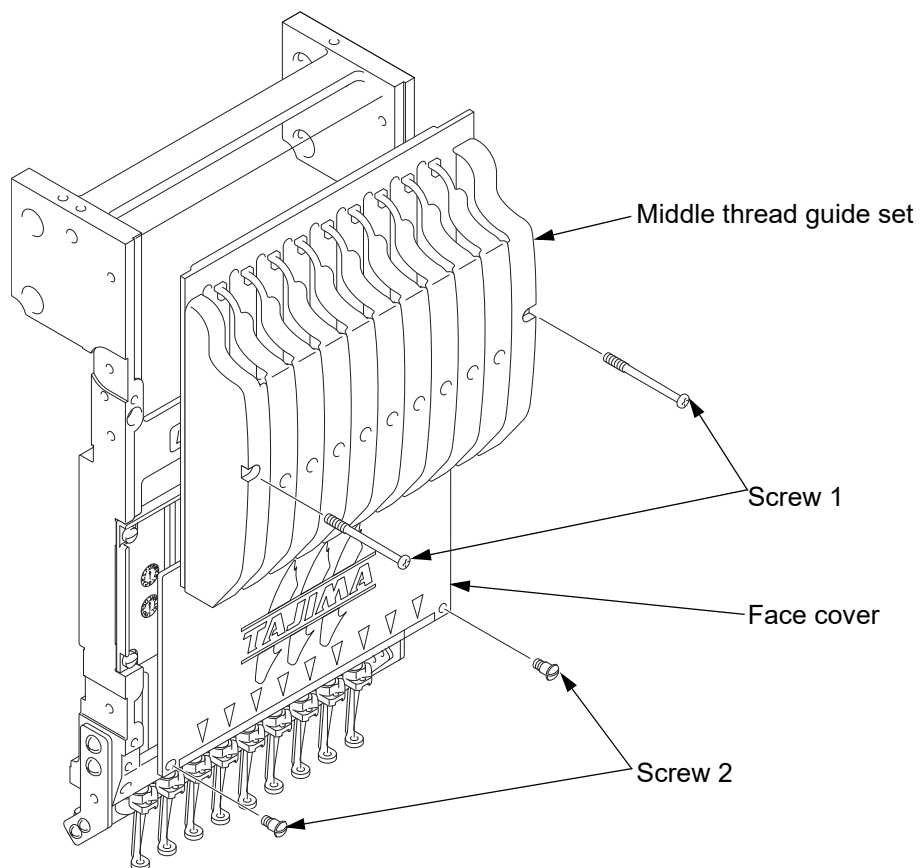

- (2)** Lower twice the tension base right switch of the head which starts working from now. The presser foot will lower to the lower dead point.

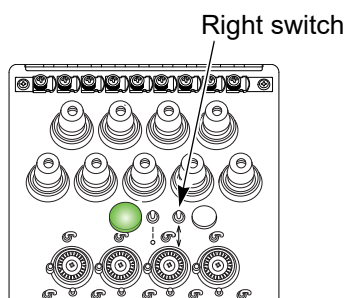

- (3) Insert the main shaft handle into the left-side box, and turn the main shaft handle clockwise to set the main shaft angle to 193° (Needle bar lower dead point).

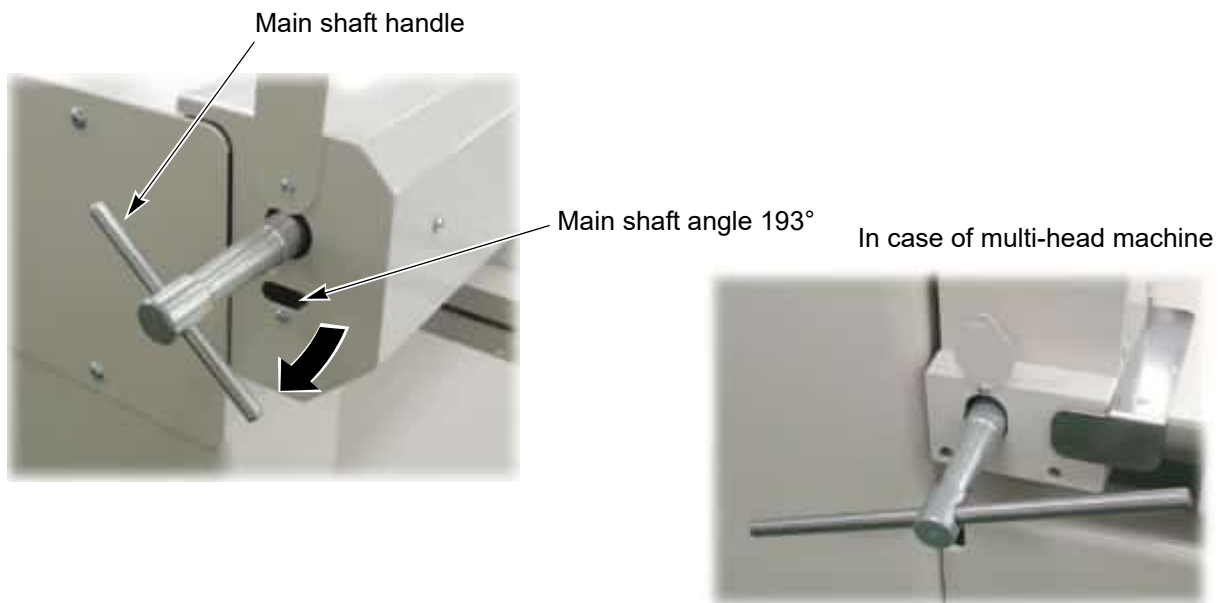

- (4) Lower the needle bar, and loosen the screw. (Photo A) Put the lower dead point gauge on the needle plate. (Photo B)

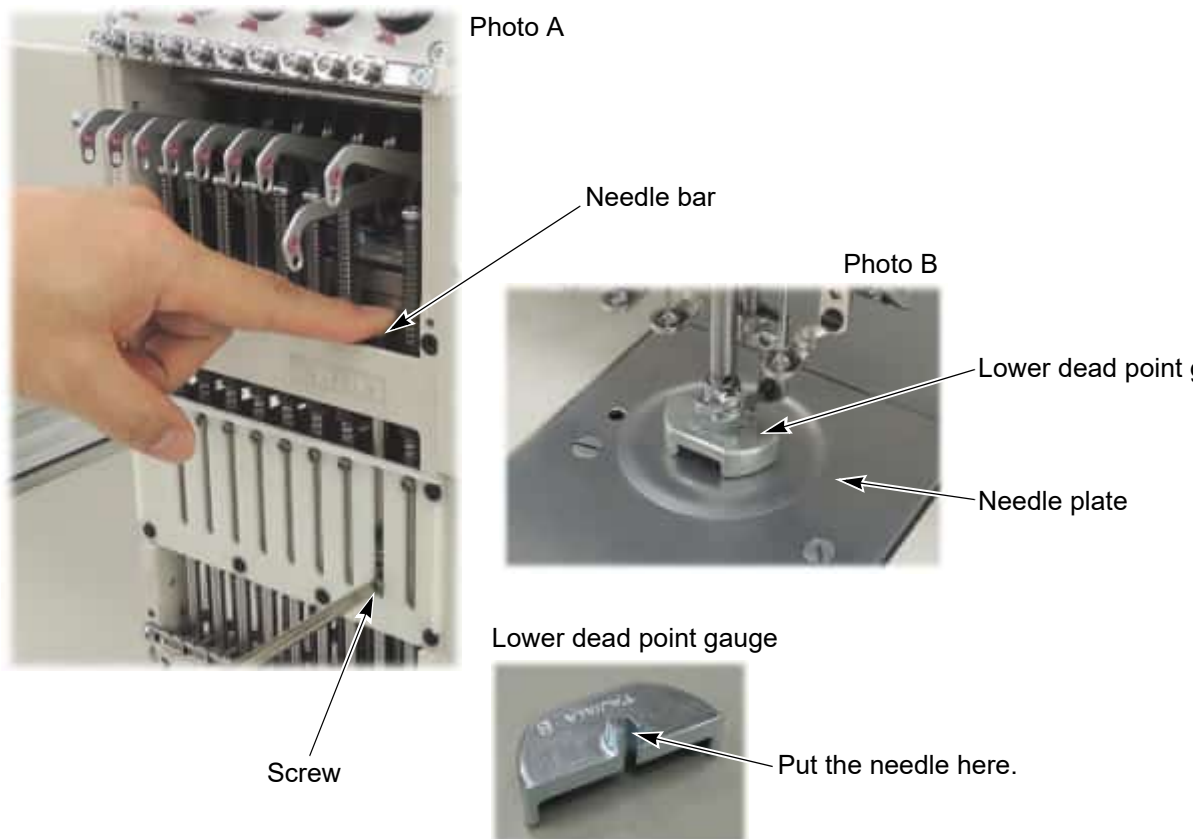

- (5) Touch the tip of the needle bar to the lower dead point gauge (Photo A), and tighten the screw in the state of the needle clamp in the figure 1.

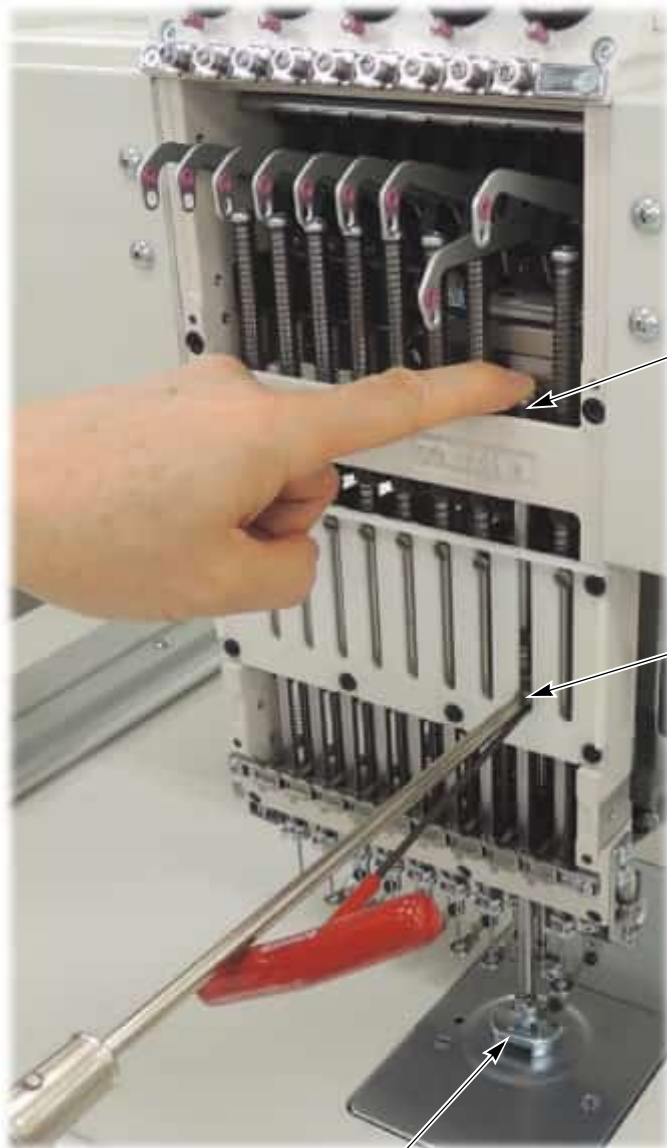

Needle bar

Needle bar connecting stud



Screw

Tighten the screw in the state that the needle bar connecting stud is raised shown in the figure below. In this example, the wrench is used.

Viewing from side

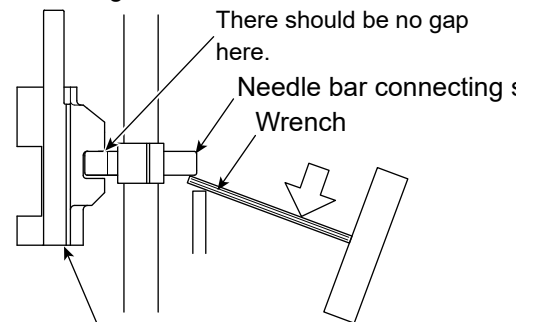

There should be no gap here.

Needle bar connecting stud

Wrench

Needle bar reciprocator

Lower dead point gauge

Photo A

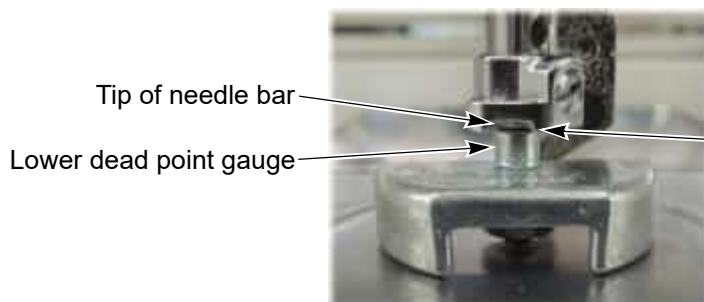

Tip of needle bar

Lower dead point gauge

There should be no gap here.

Fig. 1

This position should face the front.



(6) Detach the lower dead point gauge.

This completes the lower dead point adjustment of the second needle.

Follow the procedure below.

- a. Turn the main shaft to set the main shaft angle to 115° (Fixed position).
- b. Raise the right switch one time.
- c. Set the main shaft brake to "Yes".

(7) To perform lower dead point adjustment of other needle bar further, check it by using the connecting stud gauge based on the lower dead point of the needle bar checked at second needle.

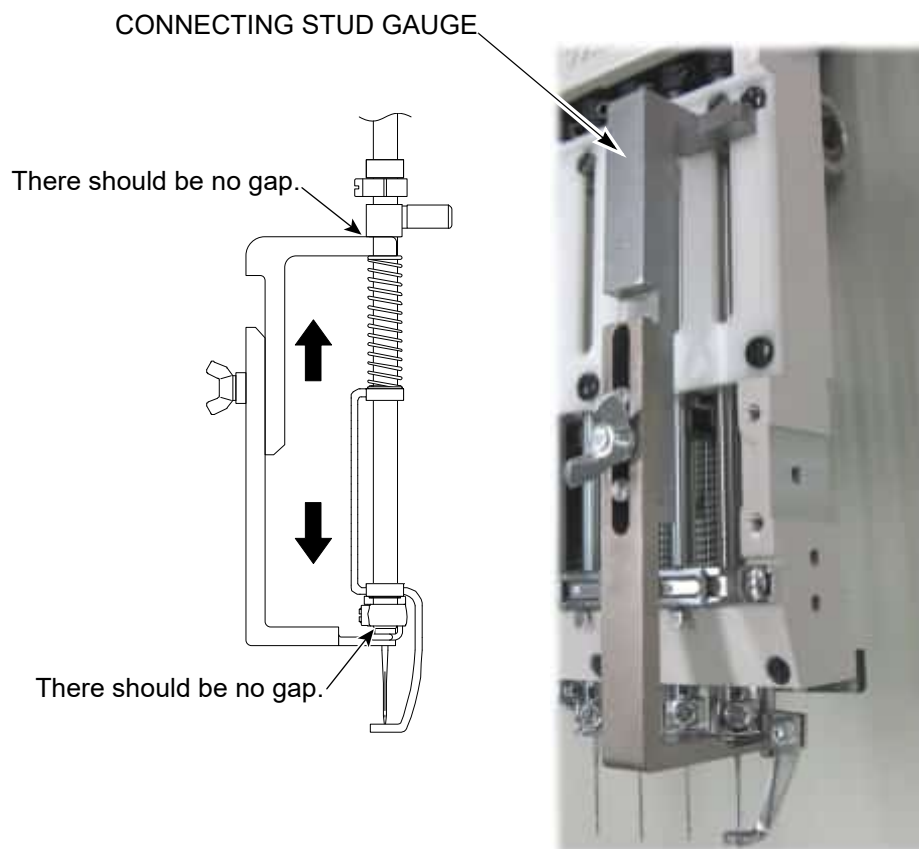

(8) Attach the detached middle thread guide set and the face cover.

1-3. Adjustment of upper dead point (Input of the password is necessary)

(1) Remove screws and detach the middle thread guide set.

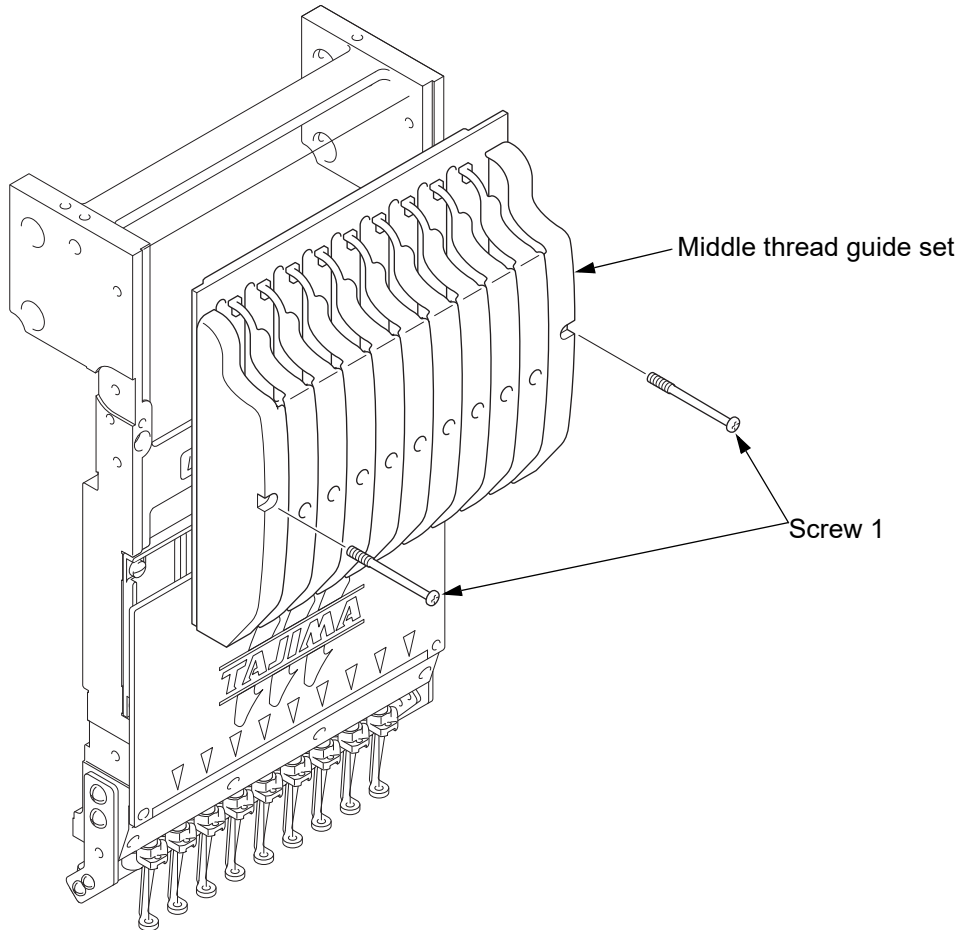

Select "Needle bar upper dead point adjustment" by the following procedure.

Icon G

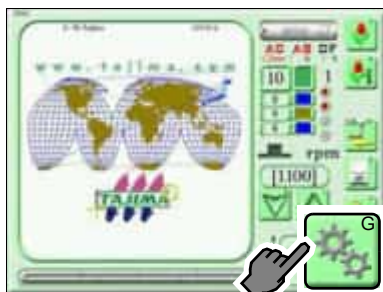

Press P6 twice.

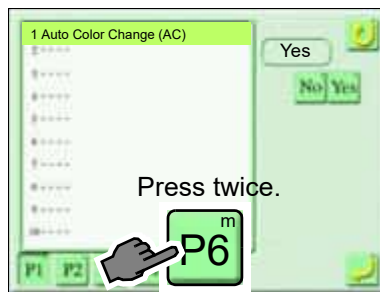

Icon S

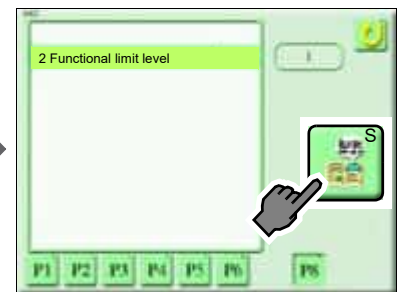

Input a password.



To set



SEL

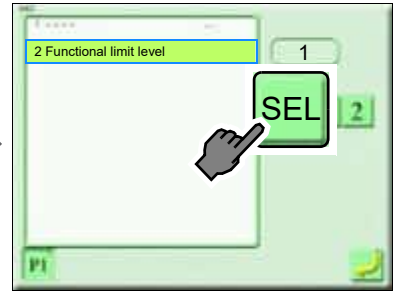

Icon T

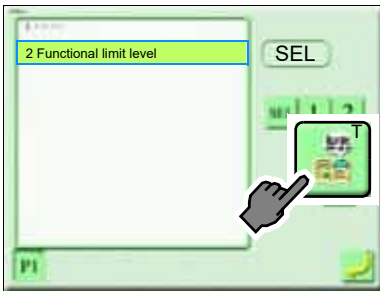

ALL Yes

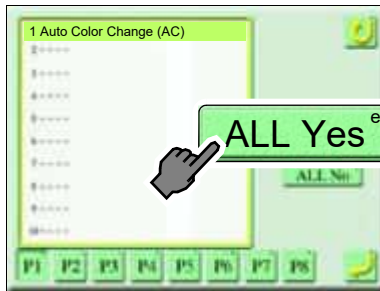

Outer frame turns yellow during setting level SEL.

Yellow

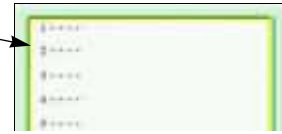

To set

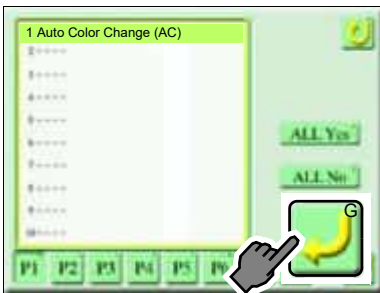

To set

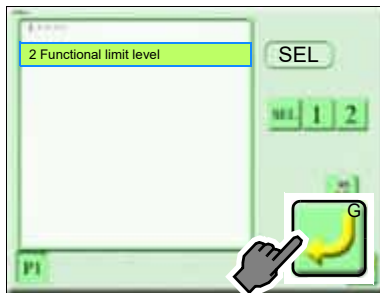

Icon A

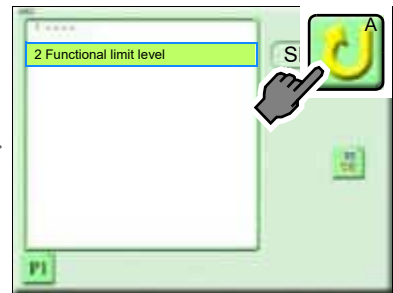

85 Machine adjustment

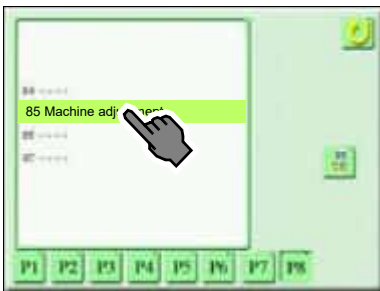

Icon T

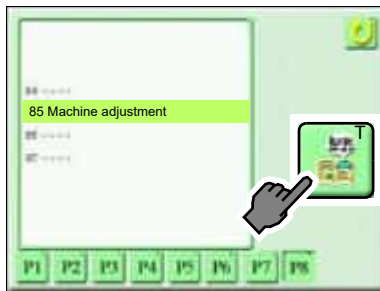

P2

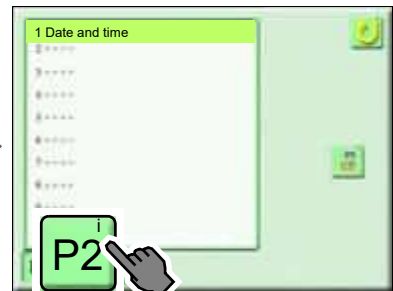

20 Needle bar upper dead point adjustment



Icon T

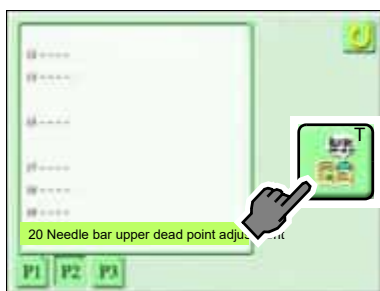

- (2) Start the machine. The machine will perform the following operations (a to c).
- a. The needle bar case will move to the next needle bar.
 - b. The presser foot will lower.
 - c. The main shaft will turn to the upper dead point (0°).
- (3) Loosen the screw of the upper dead point stopper, and tighten it again with the screw facing the front.(1 or 2 in the figure A below)

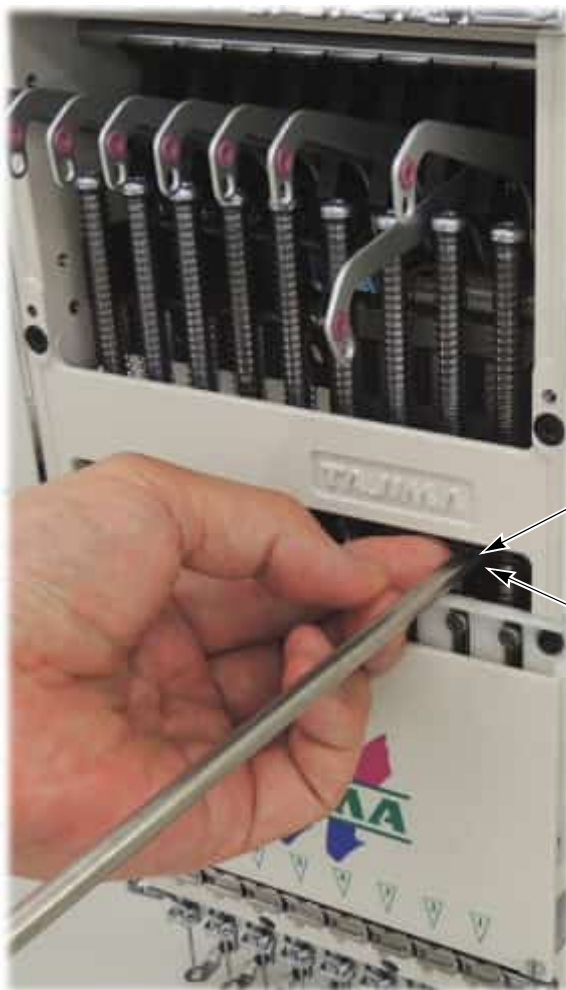
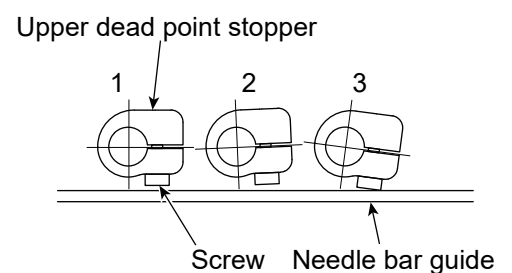

Fig. A Viewing from top



In the state of 3 in the figure A above, the upper dead point stopper touches the needle bar guide.

Screw

Upper dead point stopper

Tighten the screw with the upper dead point stopper held by fingers.

- (4) When you start the machine, the operation "a to c" described above will be performed after moving to the next needle bar. Adjust the upper dead point in the same way.

1-4. Adjusting height of presser foot (Input of the password is necessary)

Return the height of the presser foot to the correct height at shipment from the factory by using the accessory "Presser foot gauge".

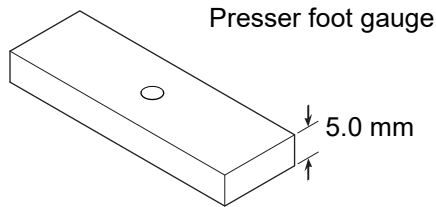

The hole of the presser foot gauge is used for positioning the presser foot by the needle lowered to the hole.

Perform this work when the actual height (figure B) of the presser foot lower dead point is different from the value (figure A) on the operation panel as shown in the following figures.

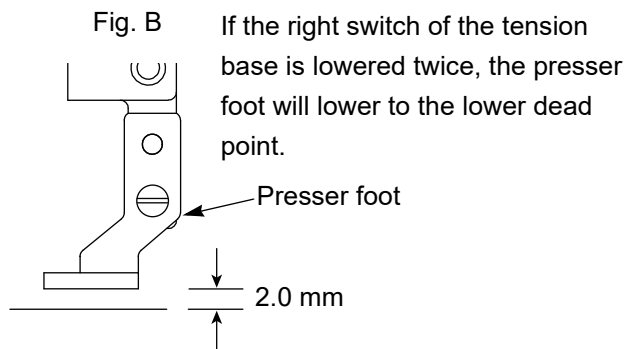
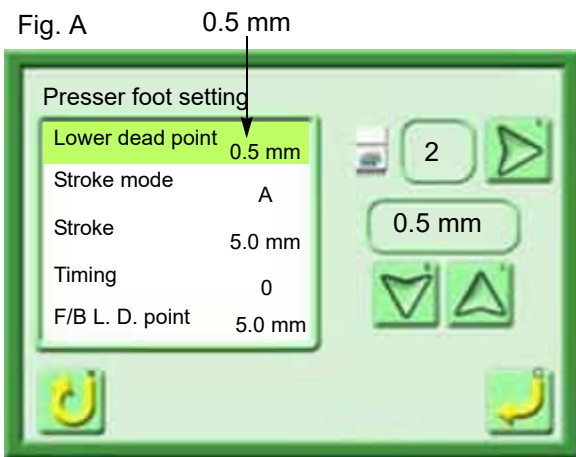

To perform this work, input of the password is necessary. After input of the password, the following operation will become possible until you turn ON the power again next time. For details, consult the distributor.

[How to adjust]

Adjust the height of the presser foot of the third needle at the second head.

(1) Perform Color Change to the third needle by operating on the operation panel.

Select "Presser foot installation" by the following procedure.

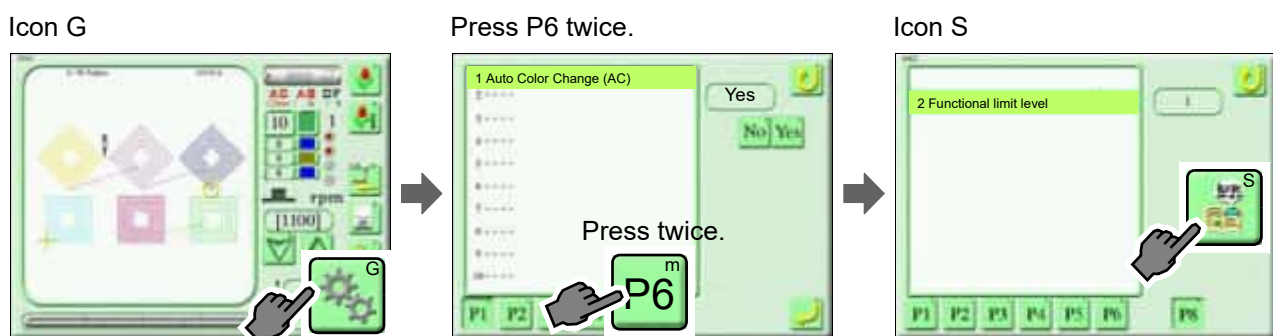

All sorts of adjusting methods for H head (PAX, HAR)

Input a password.



To set



SEL

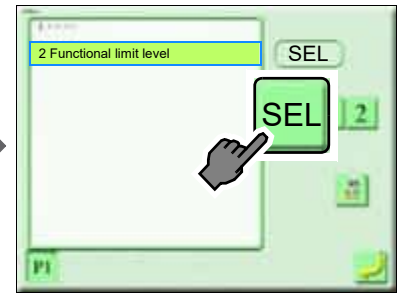

Icon T

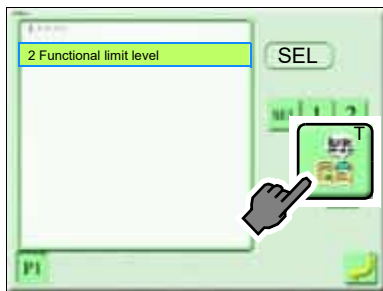

ALL Yes

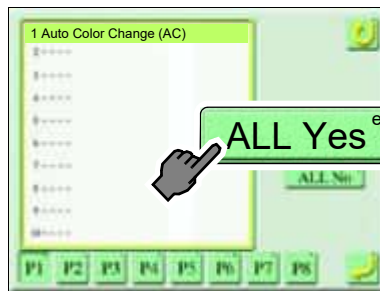

To set

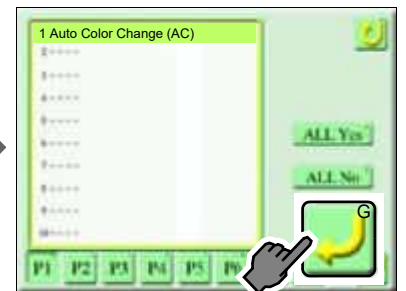

To set

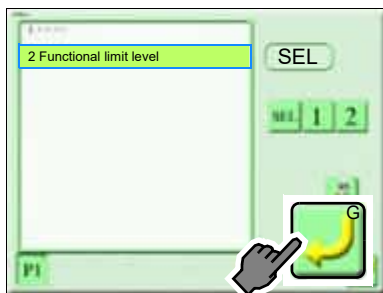

Icon A

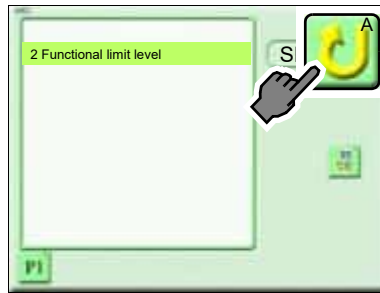

85 Machine adjustment

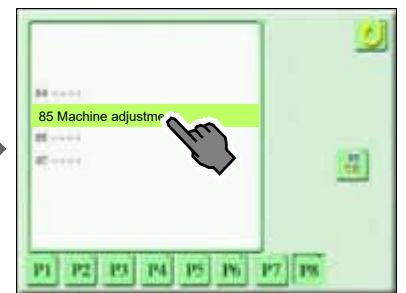

Icon T

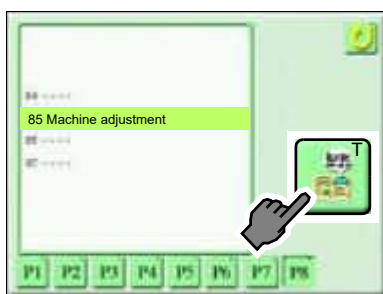

P2

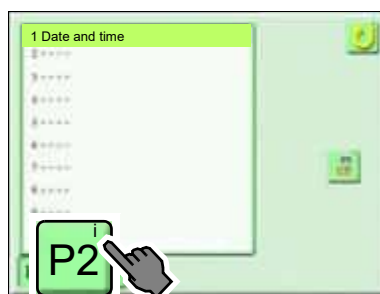

19 Presser foot installation



Icon T

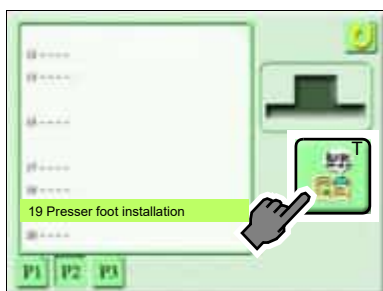

Proceed to the next work.



(2) Lower the right switch at the second head one time. The presser foot will lower and the right lamp will be lit.

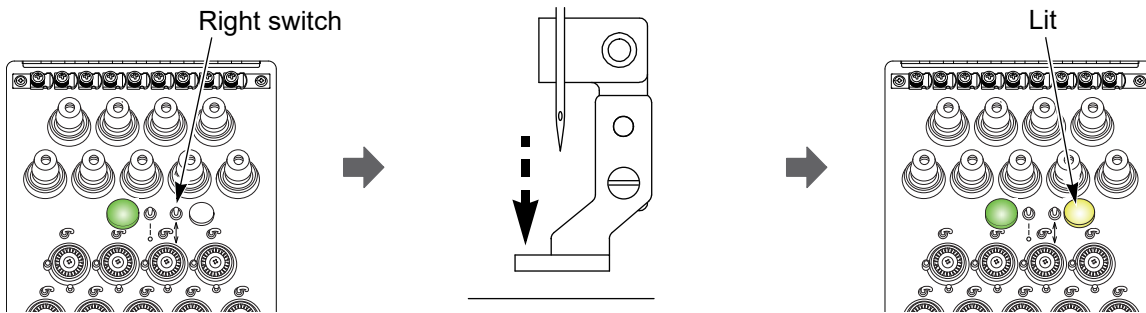

(3) Loosen the screw and place the presser foot gauge on the needle plate.

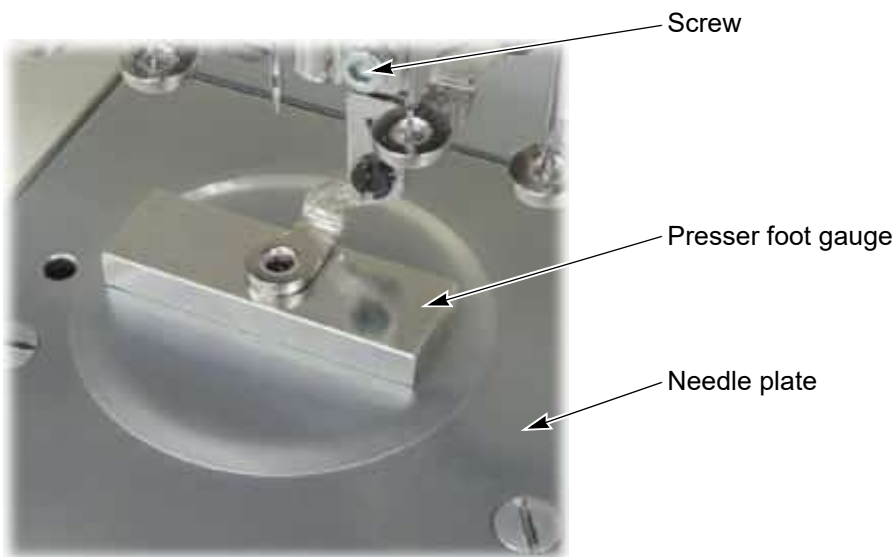

(4) Touch the presser foot to the presser foot gauge.

Tighten the screw so that the needle is located at the center of the hole of the presser foot. If the right lamp is unlit during operation, adjust it again.

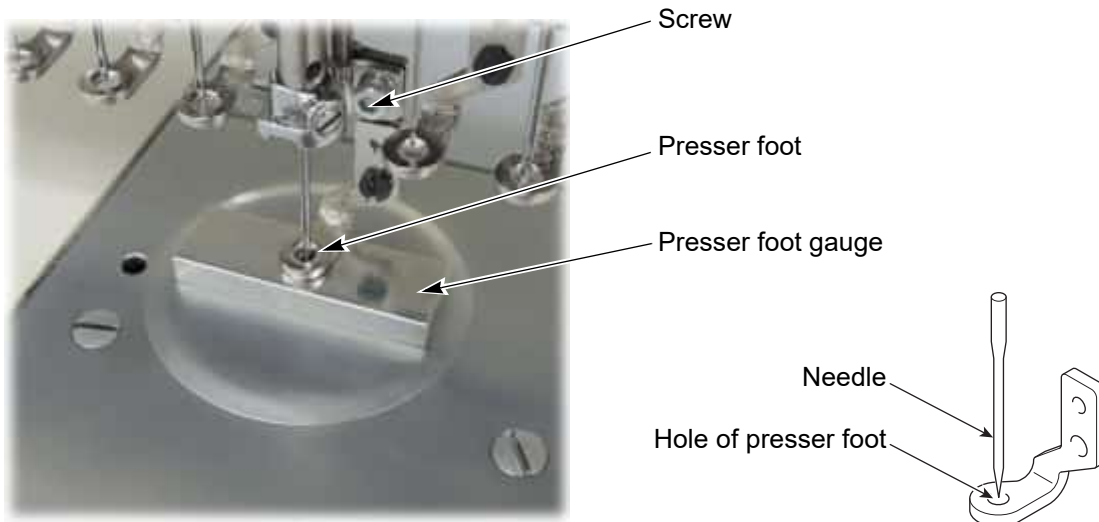

(5) Icon A (Completed)



When adjusting the presser foot of the next needle bar continuously, start the operation. The presser foot will rise, and the needle bar case will move to the next needle bar. Since lowering the right switch one time will lower the presser foot, perform adjustment in the same way.

1-5. Screw gear

- (1)** Check "Play" between the screw gear A and the screw gear B. Regarding "Play", it is normal if the screw gear A moves slightly (0.1 to 0.2 mm).
- (2)** When adjustment is necessary, loosen the screw of the screw gear B to adjust the play.

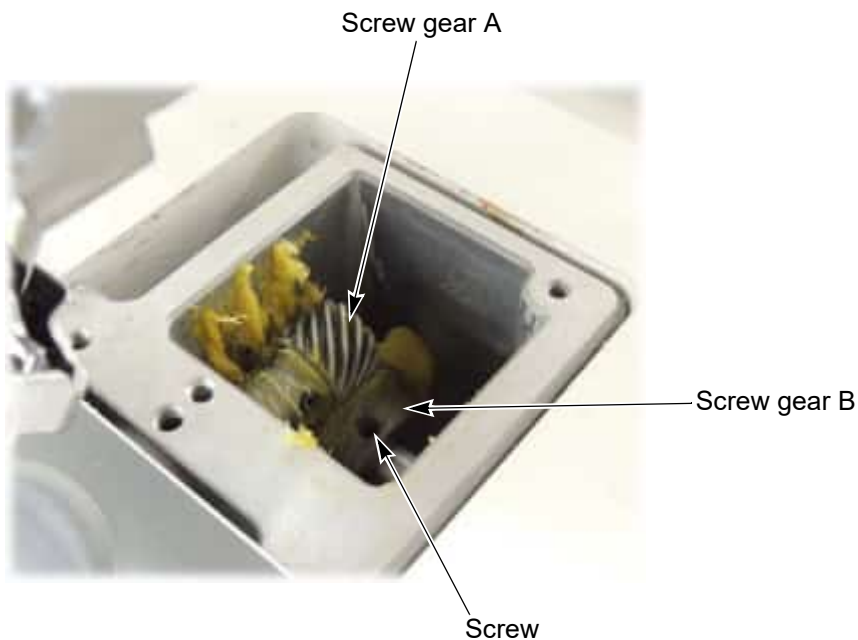

1-6. Needle and rotary hook

This working checks the first needle and the last needle of all heads.

- (1) Release "Main shaft brake". (Refer to p.38)
- (2) Lower one time the tension base right switch of the head which starts working from now. The presser foot will lower.

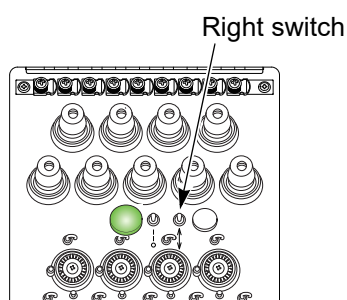

- (3) Loosen fixing screws of the rotary hook.

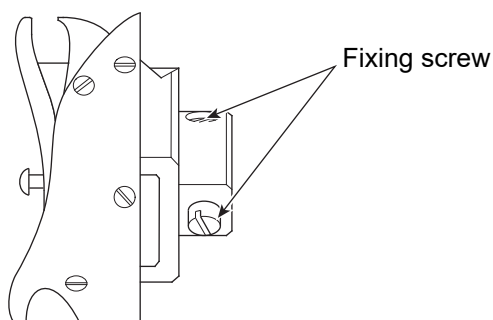

- (4) Insert the main shaft handle into the left-side box, and turn the main shaft handle clockwise to set the main shaft angle to $213\pm 1^\circ$.

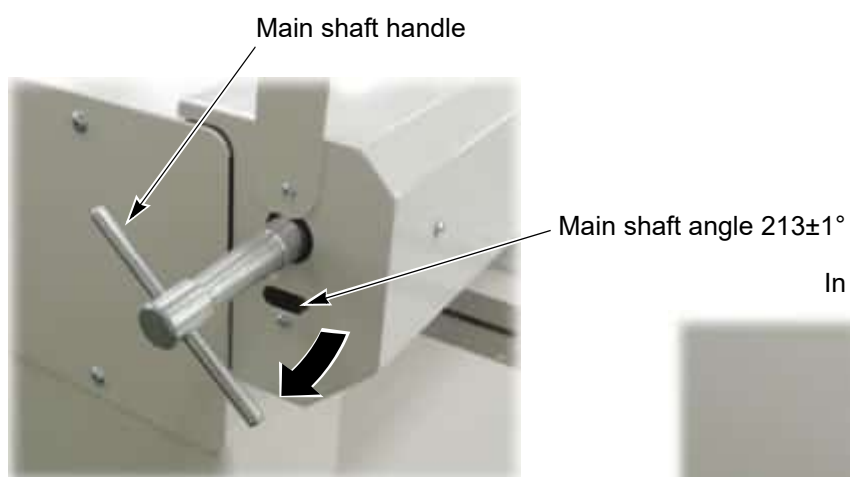

In case of multi-head machine



- (5)** Lower the needle bar to adjust the front and back positions of the rotary hook so that the space between the needle and the hook point of the rotary hook becomes 0.1 to 0.3 mm.

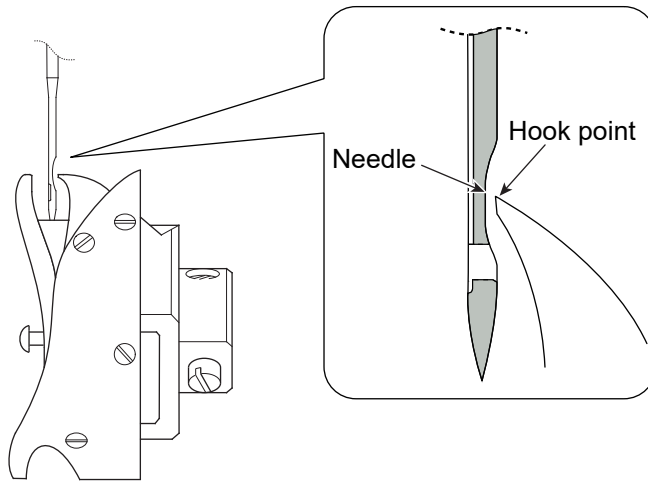

- (6)** Tighten fixing screws of the rotary hook.

2. All sorts of adjusting methods for P head (PAX, PAR)

2-1. Needle bar lower dead point adjustment (Input of the password is necessary)

CAUTION

 Do not perform this adjustment in the state of loading weight on the table (something is leaning on the table). It is not possible to adjust correctly while loading.

- (1) Release "Main shaft brake". (Refer to p.38)
- (2) Lower twice the tension base right switch of the head which starts working from now. The presser foot will lower to the lower dead point.

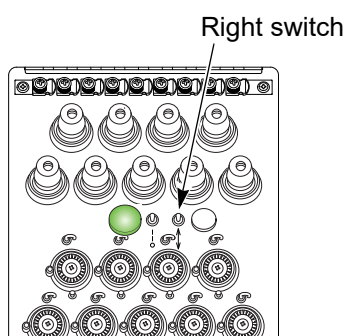

- (3) Insert the main shaft handle into the left-side box, and turn the main shaft handle clockwise to set the main shaft angle to 191° (Needle bar lower dead point).

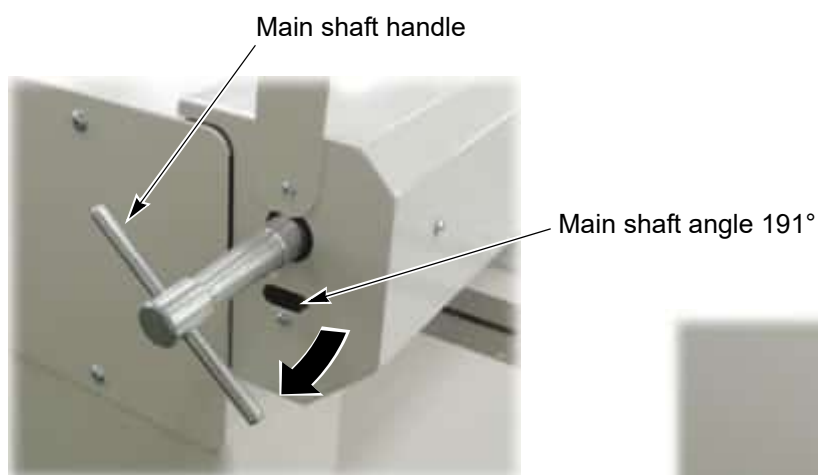

In case of multi-head machine



- (4) Lower the needle bar, and loosen the screw. Put 0.1 mm spacer on the perforator table. If your machine is equipped with the Auto. PP tape feeder, remove the perforator base needle plate in advance.

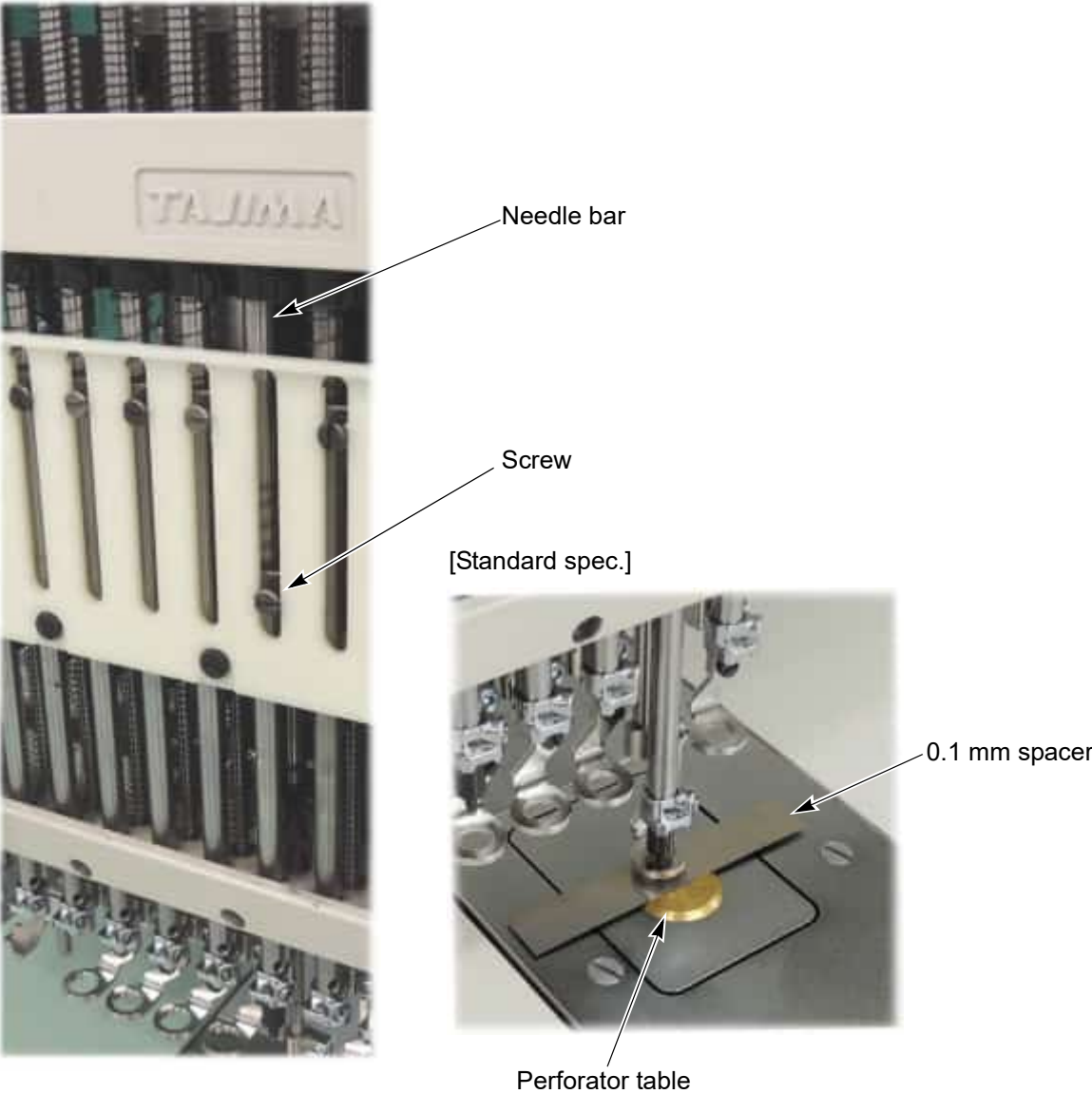

[Machine equipped with auto. PP tape feeder]

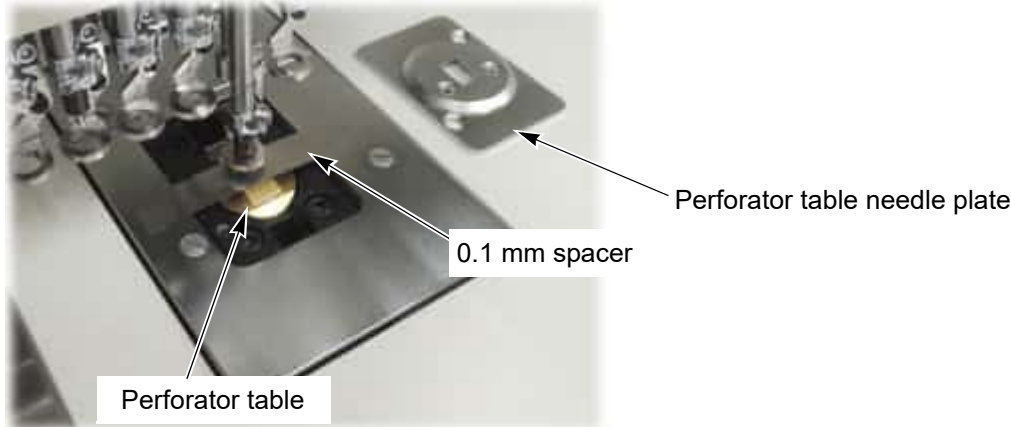

- (5) Touch the tip of the perforator needle to 0.1 mm spacer, and tighten the screw in the state of the needle clamp in the figure 1.

Example of standard spec.



Tip of perforator needle
0.1 mm spacer

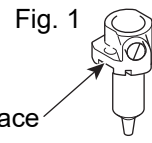

This position should face the front.

Needle bar connecting stud



Screw

Tighten the screw in the state that the needle bar connecting stud is raised shown in the figure below. In this example, the wrench is used.

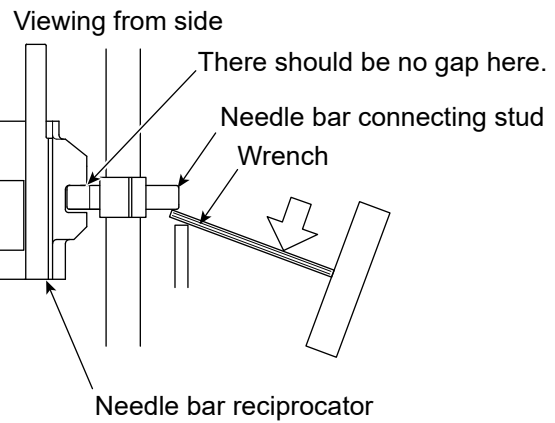

- (6)** Move up/down the needle clamp by hand to check if there is no play. If there is any play, adjust it again.



Example of standard spec.

Needle clamp

This completes the lower dead point adjustment of the second needle. The lower dead point adjustment of other needle is the same as this procedure.

To finish here, follow the procedure below.

- a. Turn the main shaft to set the main shaft angle to 115° (Fixed position).
 - b. Raise the right switch one time.
 - c. Set the main shaft brake to "Yes".
- (7)** To perform lower dead point adjustment of other needle bar further, check it by using the connecting stud gauge based on the lower dead point of the needle bar checked at second needle. (Refer to p.43)

2-2. Adjustment of upper dead point (Input of the password is necessary)

Select "Needle bar upper dead point adjustment" by the following procedure.

Icon G

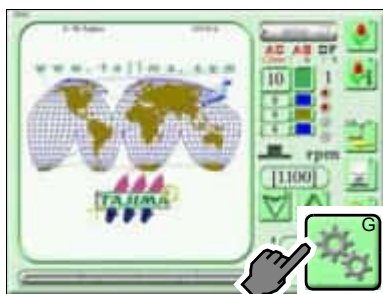

Press P6 twice.

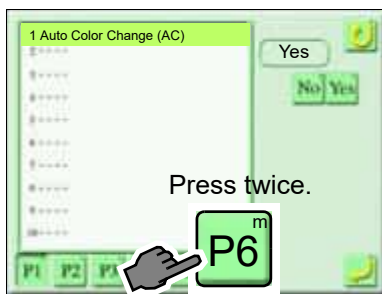

Icon S

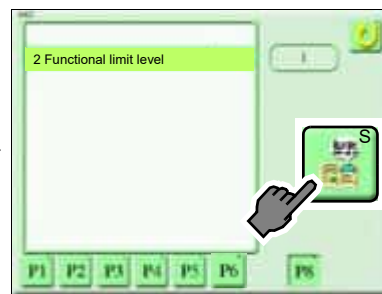

Input a password.



To set



SEL

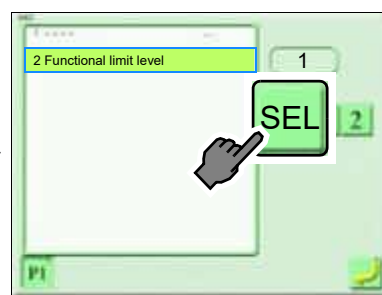

Icon T

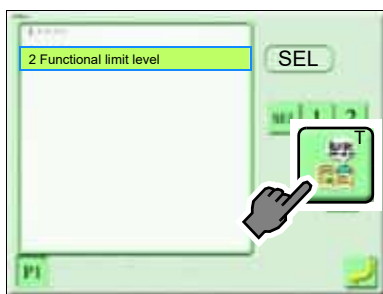

ALL Yes

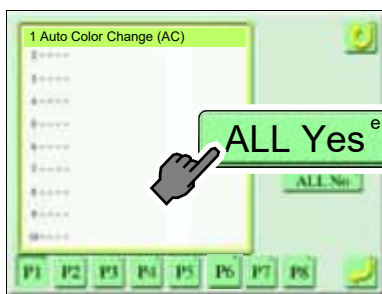

Outer frame turns yellow during setting level SEL.

Yellow

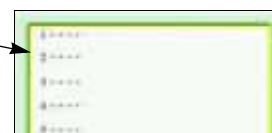

To set

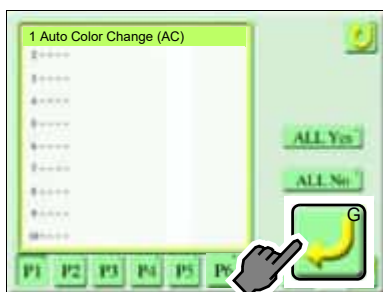

To set

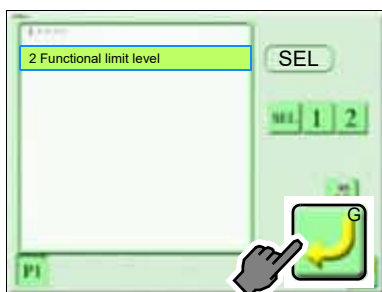

Icon A

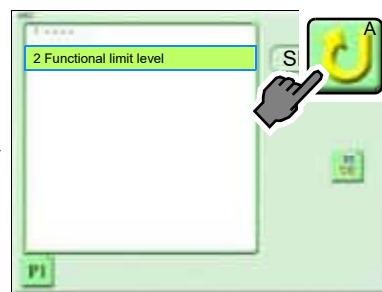

85 Machine adjustment

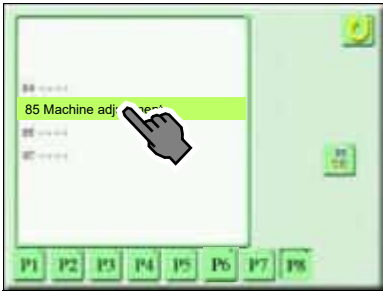

Icon T

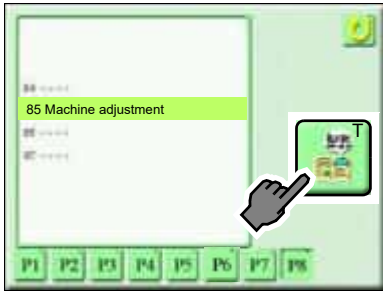

P2

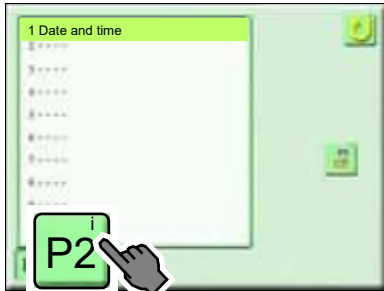

20 Needle bar upper dead point adjustment



Icon T

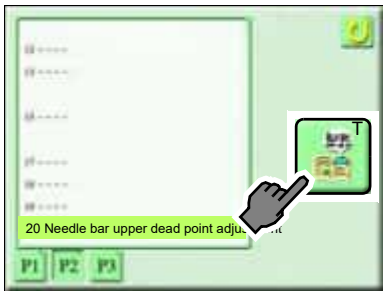

- (1)** Start the machine. The machine will perform the following operations (a to c).
 - a. The needle bar case will move to the next needle bar.
 - b. The presser foot will lower.
 - c. The main shaft will turn to the upper dead point (0°).

- (2)** Loosen the screw of the upper dead point stopper, and tighten it again with the screw facing the front.(1 or 2 in the figure A below)

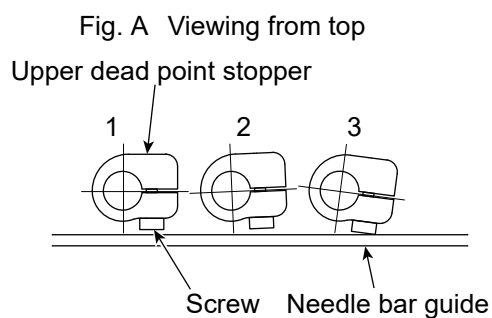

In the state of 3 in the figure A above, the upper dead point stopper touches the needle bar guide.

Upper dead point stopper

Tighten the screw with the upper dead point stopper held by fingers.

- (3)** When you start the machine, the operation "a to c" described above will be performed after moving to the next needle bar. Adjust the upper dead point in the same way.

2-3. Adjusting height of presser foot (Input of the password is necessary)

Return the height of the presser foot to the correct height at shipment from the factory by using the accessory "Presser foot gauge".

Presser foot gauge



Thickness: 15 mm

The hole of the presser foot gauge is used for positioning the presser foot by lowering the perforator needle to the hole.

Perform this work when the actual height (figure B) of the presser foot lower dead point is different from the value (figure A) on the operation panel as shown in the following figures.

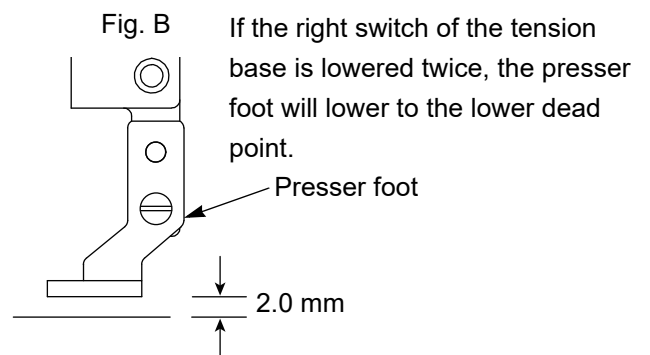
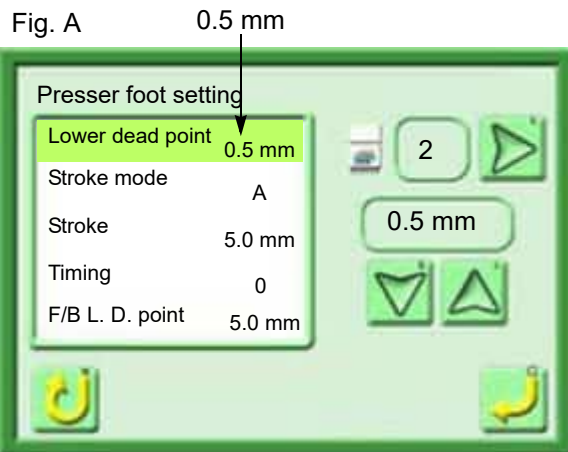

To perform this work, input of the password is necessary. After input of the password, the following operation will become possible until you turn ON the power again next time. For details, consult the distributor.

[How to adjust]

Example: Adjust the height of the presser foot of the second needle at the first head.

(1) Perform Color Change to the second needle by operating on the operation panel.

Select "Presser foot installation" by the following procedure.

Icon G



Press P6 twice.

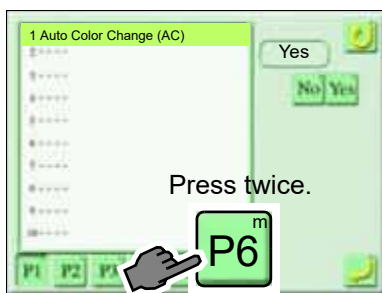

Icon S

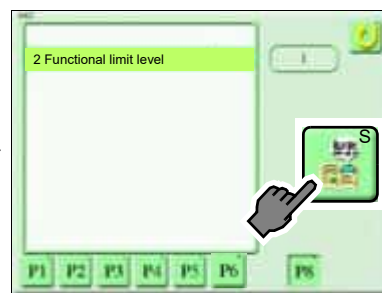

Input a password.



To set



SEL

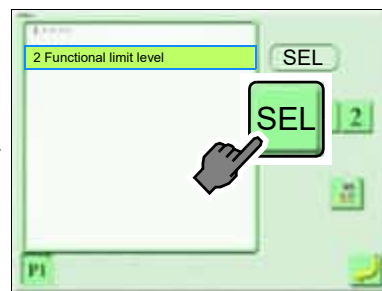

Icon T

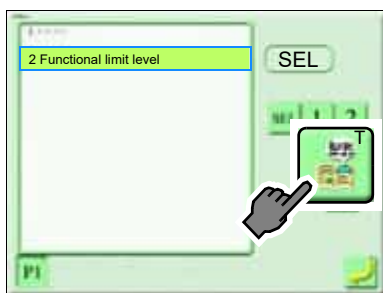

ALL Yes

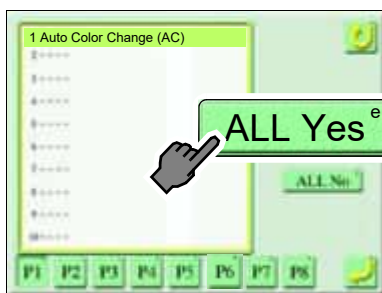

To set

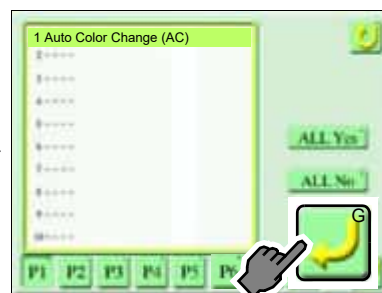

To set

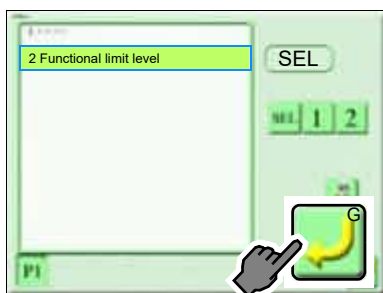

Icon A

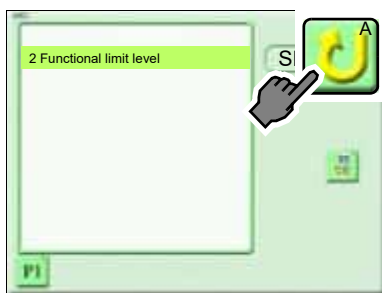

85 Machine adjustment

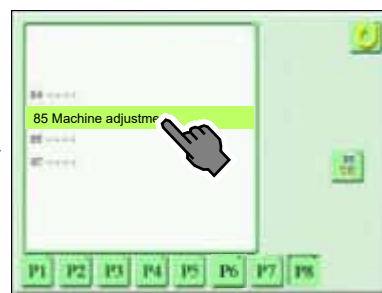

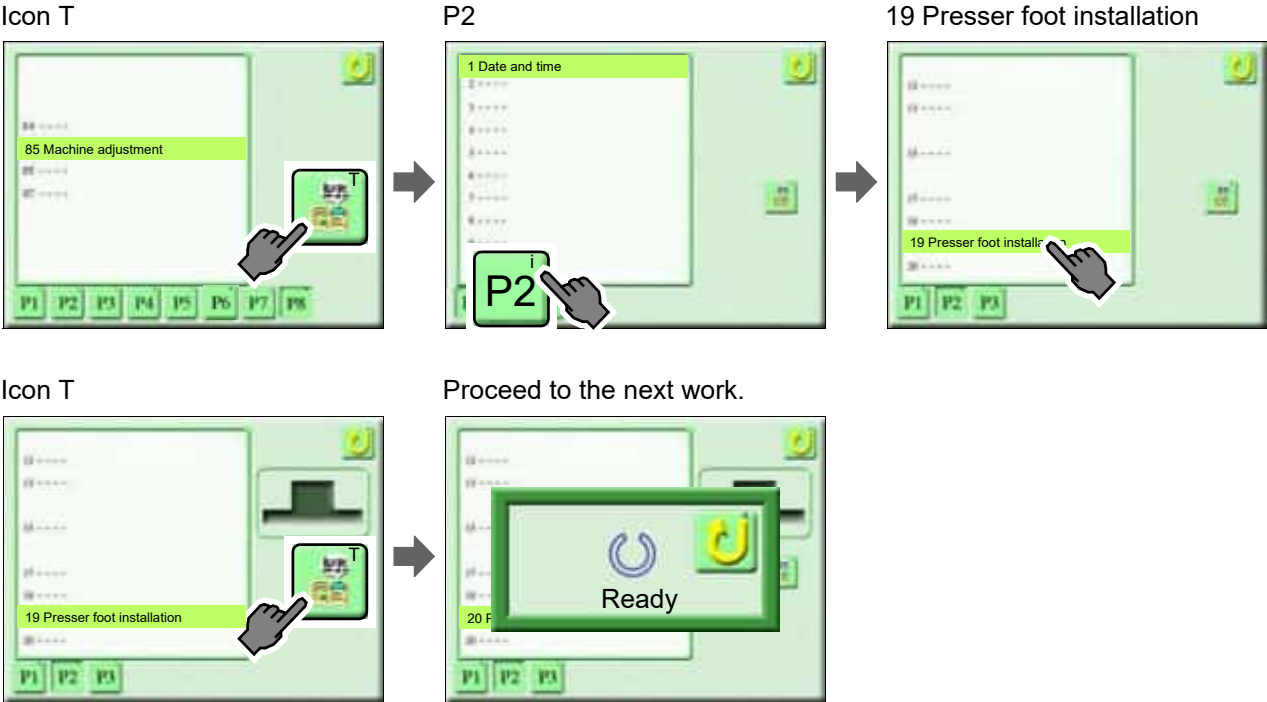

(2) Lower the right switch at the first head one time. The presser foot will lower and the right lamp will be lit.

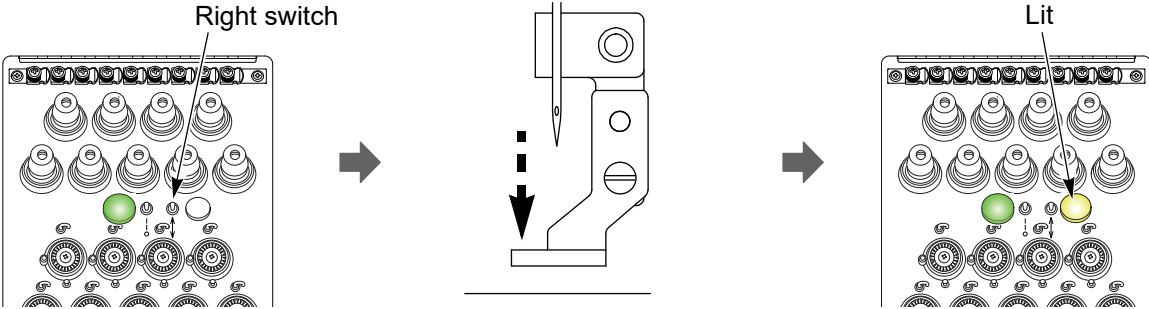

(3) Loosen the screw and place the presser foot gauge.

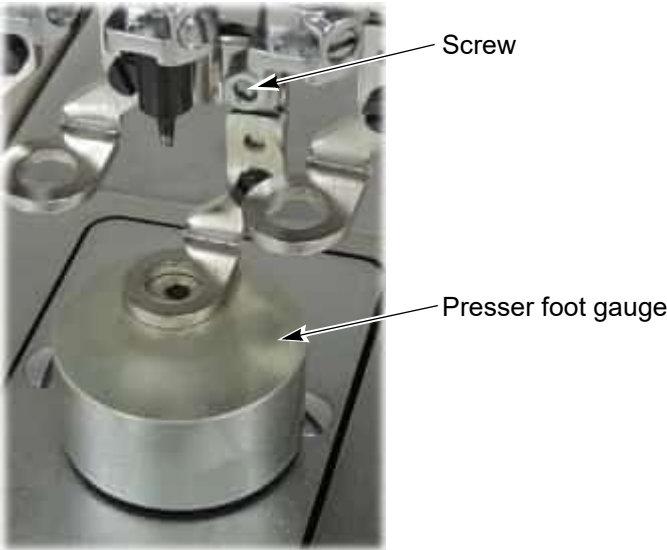

(4) Touch the presser foot to the presser foot gauge.

Tighten the screw so that the perforator needle is located at the center of the hole of the presser foot. If the right lamp is unlit during operation, adjust it again.

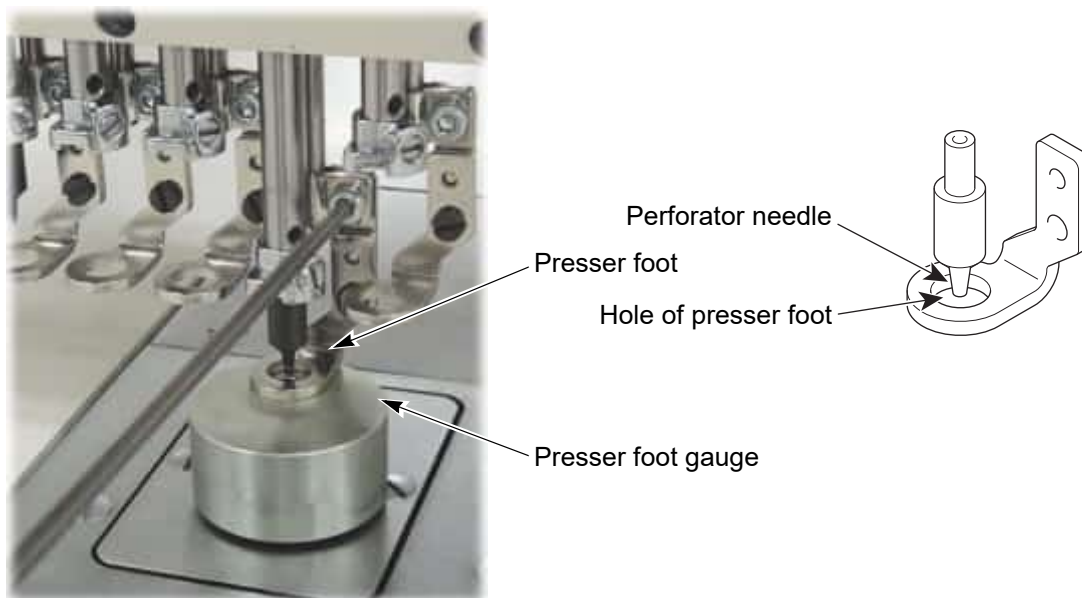

(5) Icon A (Completed)

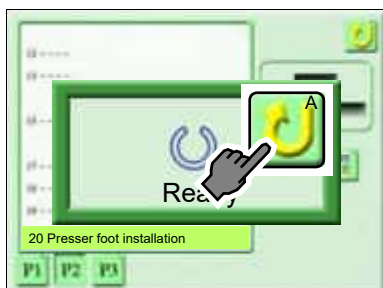

When adjusting the presser foot of the next needle bar continuously, start the operation. The presser foot will rise, and the needle bar case will move to the next needle bar. Since lowering the right switch one time will lower the presser foot, perform adjustment in the same way.

Chapter 7 Idling and test sewing

1. Lubrication

! WARNING

! To perform lubrication, turn OFF the power switch. You may sustain severe injuries by being caught in the machine.

! CAUTION

! Use only Tajima's genuine TF oil or equivalent (Viscosity grade = VG20).

1-1. H head (PAX, HAR)

(1) Rotary hook

Lubrication cycle: Once/5 to 6 hours

To lubricate, use the oiler. There are two lubricating spots, raceway and lubrication hole.

Oiler (accessory)

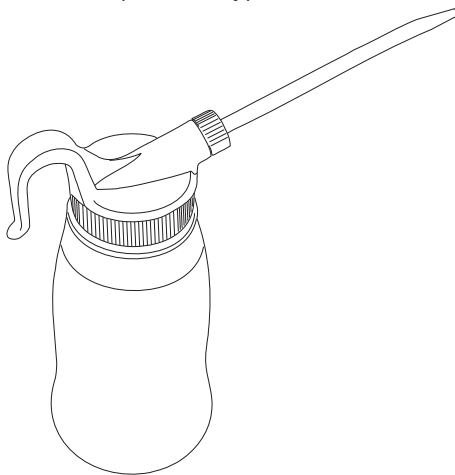

Raceway

Lubrication hole (red mark)



To lubricate lubrication hole, attach the nozzle (accessory) to the tip of the oiler.



Nozzle

(2) H head

Lubrication cycle: Once/3 months

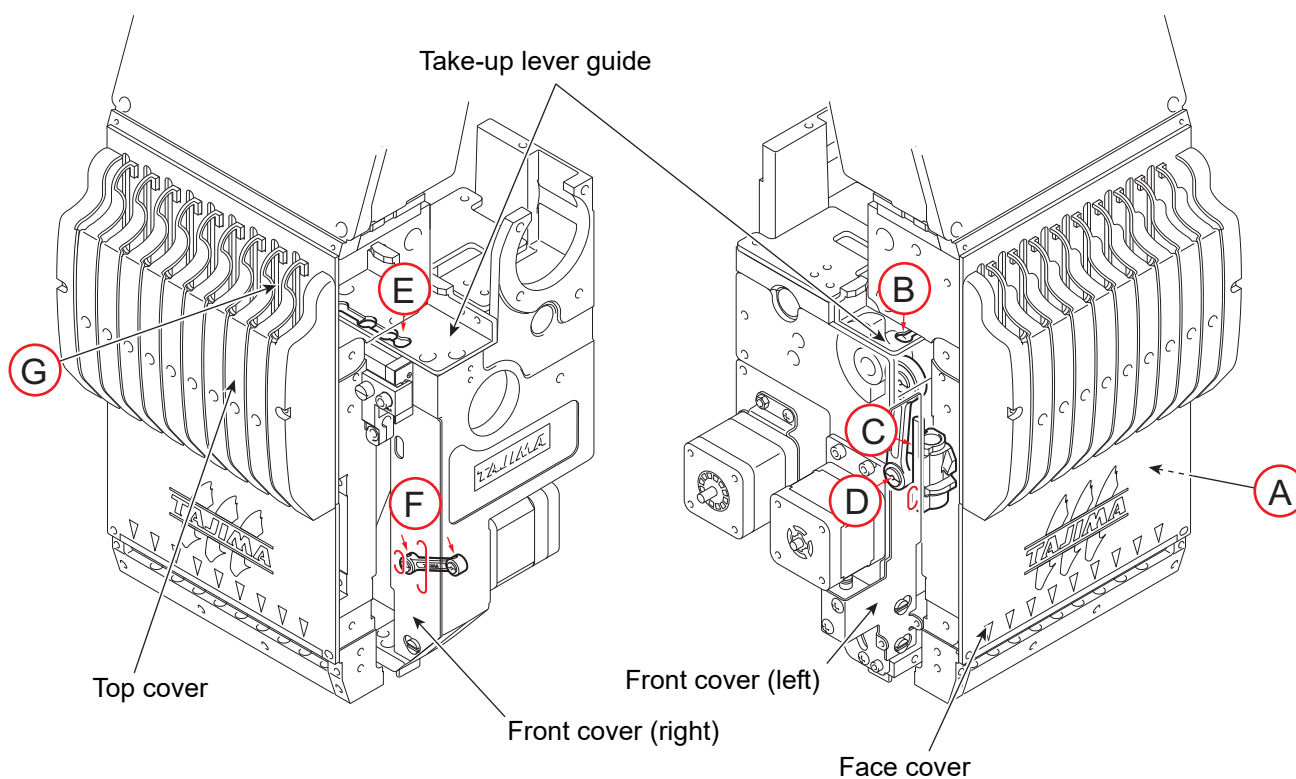

Lubricating spot	How to lubricate
A: Needle bar	Detach the face plate and lubricate. (Refer to p.66)
B: Needle bar drive shaft (needle bar side)	Lubricate from hole of take-up lever guide.
C: Needle bar reciprocator	Lubricate into hole (red) of front cover (left).
D: Connecting rod (needle bar side)	
E: Needle bar drive shaft (presser foot side)	Lubricate from hole of take-up lever guide.
F: Connecting rod (presser foot side)	Lubricate into hole (red) of front cover (right)
G: Take-up lever boss ^[1]	Lubricate by detaching top cover.

[1]Take-up lever boss

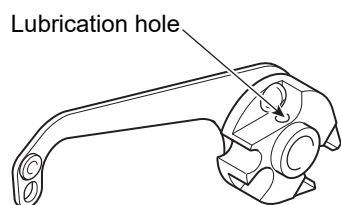

[How to lubricate needle bar]

- a. Lubricate the upper row of the needle bar case.



Lubricate by the oiler attached with the nozzle at the tip.

- b. Remove screws at two spots.

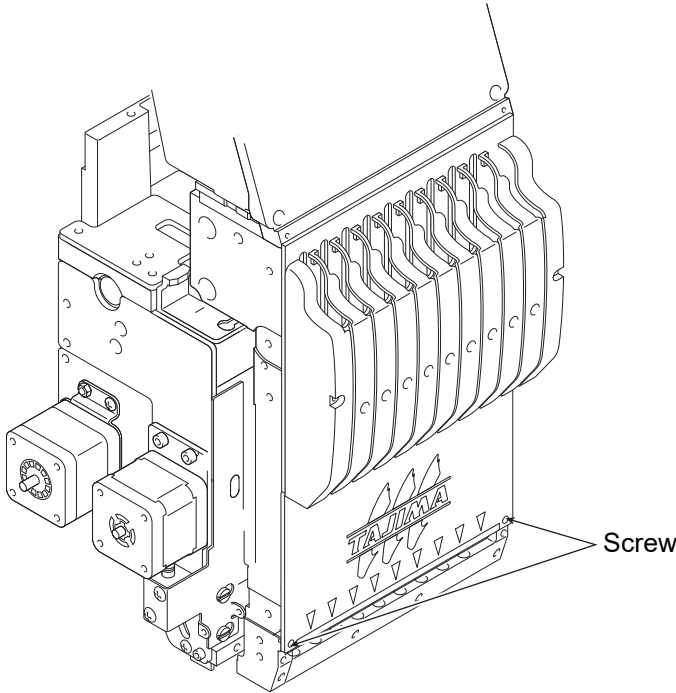

b. Lubricate the needle bar in the state that the face cover is lifted up.

Lubricate by the oiler attached with the nozzle at the tip.

Middle row of needle bar case

Nozzle



Lower row of needle bar case



1-3. P head (PAX, PAR)

Lubrication cycle: Once/3 months

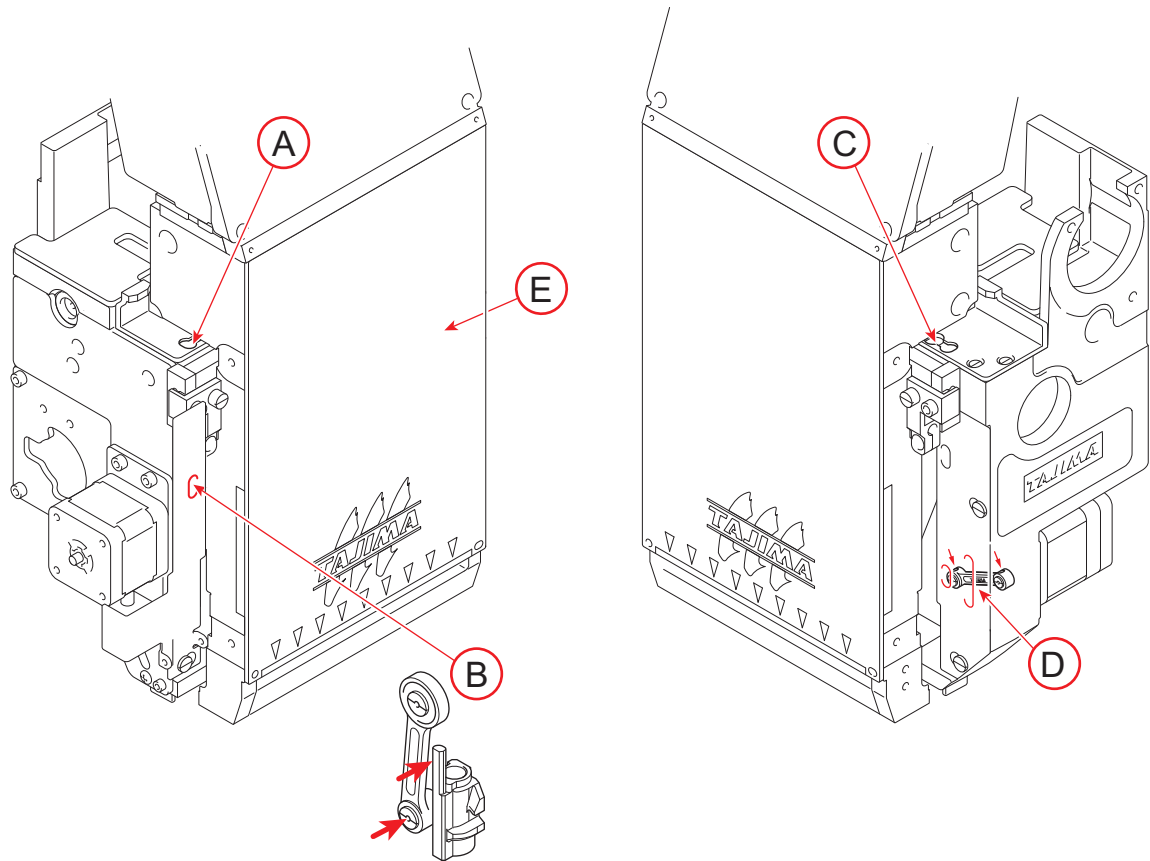

Lubricating spot	How to lubricate
A: Needle bar drive shaft (needle bar side)	Lubricate from hole of take-up lever guide.
B : Needle bar reciprocator, Connecting rod (needle bar side)	Lubricate into hole (red) of front cover (left).
C: Needle bar drive shaft (presser foot side)	Lubricate from hole of take-up lever guide.
D: Connecting rod (presser foot side)	Lubricate into hole (red) of front cover (right)
E: Needle bar	Detach the face plate and lubricate. (Refer to p.69)

[How to lubricate needle bar]

a. Lubricate the upper row of the needle bar case.



Lubricate by the oiler attached with the nozzle at the tip.

b. Remove screws at two spots.

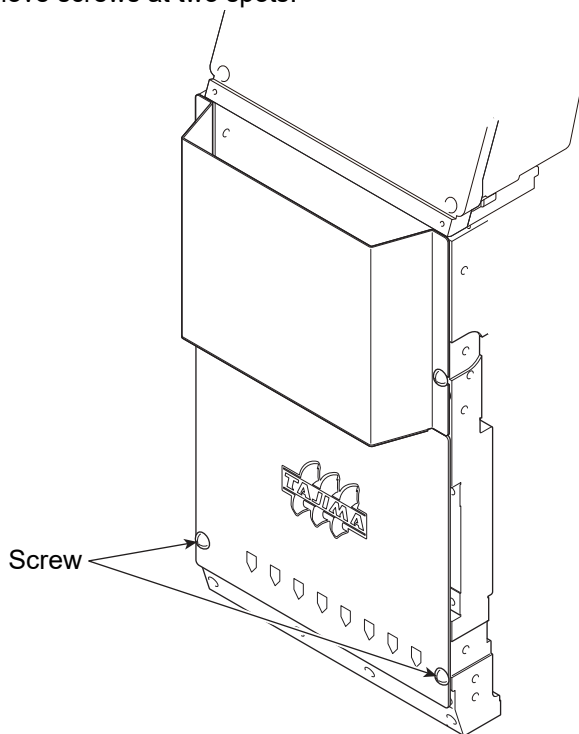

b. Lubricate the needle bar in the state that the face cover is lifted up.

Lubricate by the oiler attached with the nozzle at the tip.

Middle row of needle bar case





Nozzle

Lower row of needle bar case



2. Idling, jump

CAUTION

-  When operating the machine, check if there is no person around moving section and all covers are attached to prevent accident resulting in injury or death.
-  Keep on idling until antirust applied on rotary hook is completely removed. If antirust remains, it could cause thread breakage.

2-1. H head (PAX, HAR)

- (1) Change the following parameter settings.

[Page P3]

26 Upper thread detection → "0" (Not to detect)

27 Under thread detection (Unit) → "0" (Not to detect)

- (2) Execute the data set of the design data containing jump codes.
- (3) Start the machine to perform idling. At the beginning, start idling from about 250 rpm and increase the number of revolutions to 650 rpm while checking operating condition of the machine. Devote 20 to 30 minutes to operate the machine. Check if no misjumping occurs for any needle, using design data that includes jump codes.
- (4) When the work is completed, check if no generation of heat occurs at the needle bar case, the side section of the arm and the needle bar drive shaft, and then return the parameter setting to the previous value.

2-2. P head (PAX, PAR)

If the machine is equipped with the auto. PP tape feeder (option), set the following parameter to "No" (Do not feed PP tape).

[Page P7]

80 Extension Device Controller setting- 2 Auto. PP Tape Feeder

- (1) Execute the data set of the design data containing jump codes.
- (2) Start the machine to perform idling. At the beginning, start idling from about 250 rpm and increase the number of revolutions to 650 rpm while checking operating condition of the machine. Devote 20 to 30 minutes to operate the machine. Check if no misjumping occurs for any needle, using design data that includes jump codes.

3. Test sewing

3-1. To attach snarl-preventive parts (PAX, HAR)

Attach snarl-preventive parts (accessory) before threading.



Snarl-preventive parts

This is the part to prevent thread from snarl or loosing at thread cone.

[Snarl-preventive parts]

Q'ty	Part No.	Part name
30 sets	911400100T00	SNARL-PREVENTIVE PART :30 SET[T]
10 sets	911400200T00	SNARL-PREVENTIVE PART :10 SET[T]

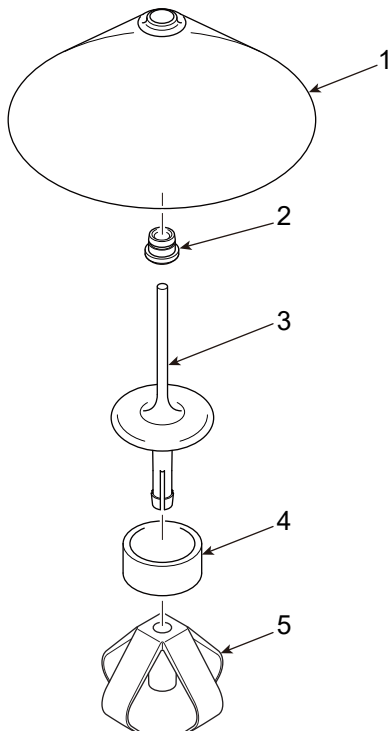

No.	Part No.	Part name
1	0D0110520000	CAP :SNARL-PREVENTIVE
2	516501010010	THREAD GUIDE COLLAR :WHITE :4.5MM DIA.
3	0D0110540000	GUIDE :SNARL-PREVENTIVE
4	0D0110550000	COLLAR :SNARL-PREVENTIVE
5	0D0110530000	HOLDER :SNARL-PREVENTIVE

[How to assemble]

- (1) Attach the guide passing through the collar to the holder.

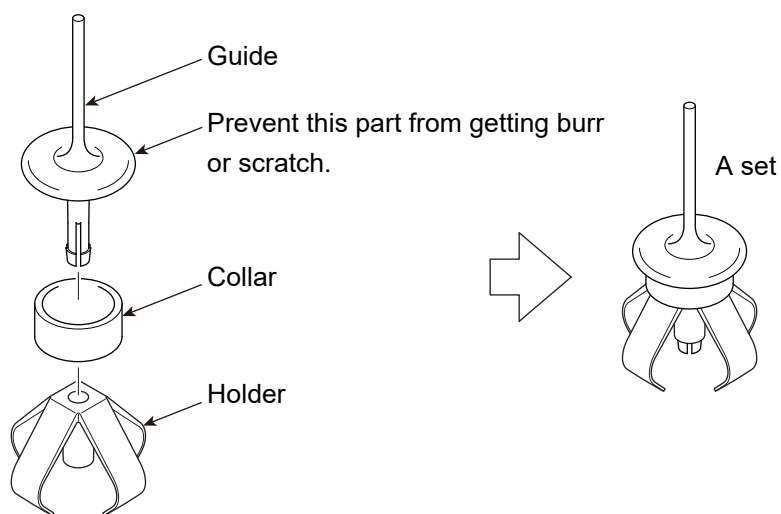

- (2) Attach the thread guide collar inside the cap.

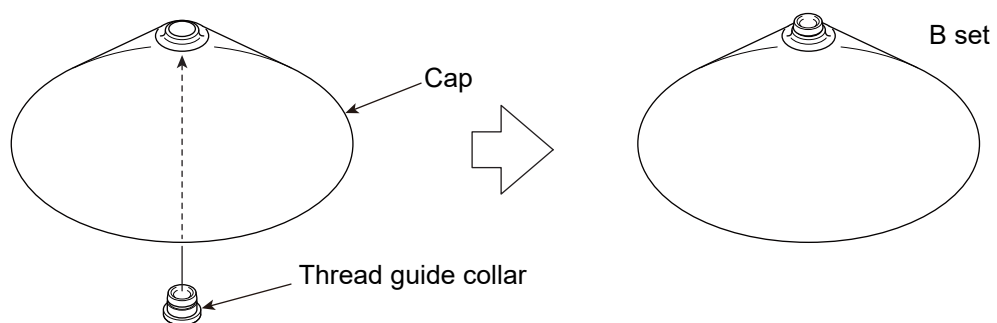

[How to use]

- (1) When the hole diameter at the upper part of the thread cone is 17 mm or more:

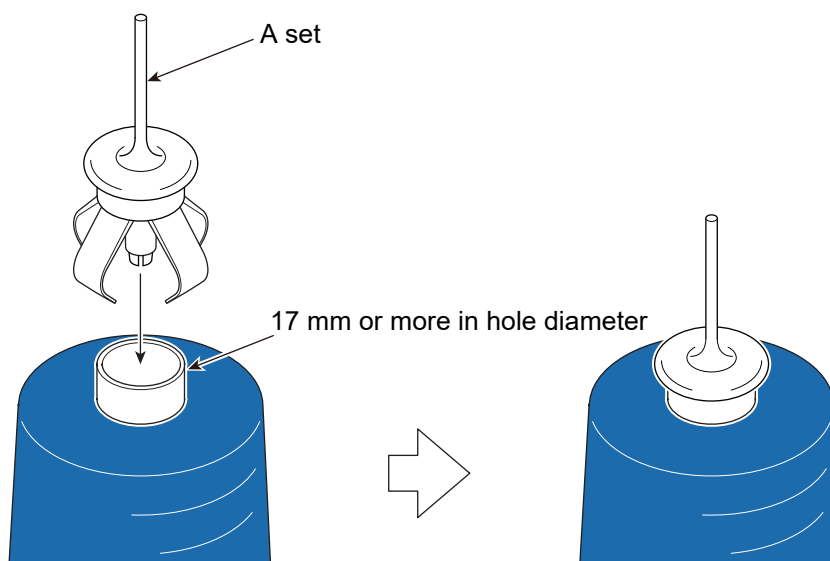

(2) When the hole diameter at the upper part of the thread cone is less than 17 mm:

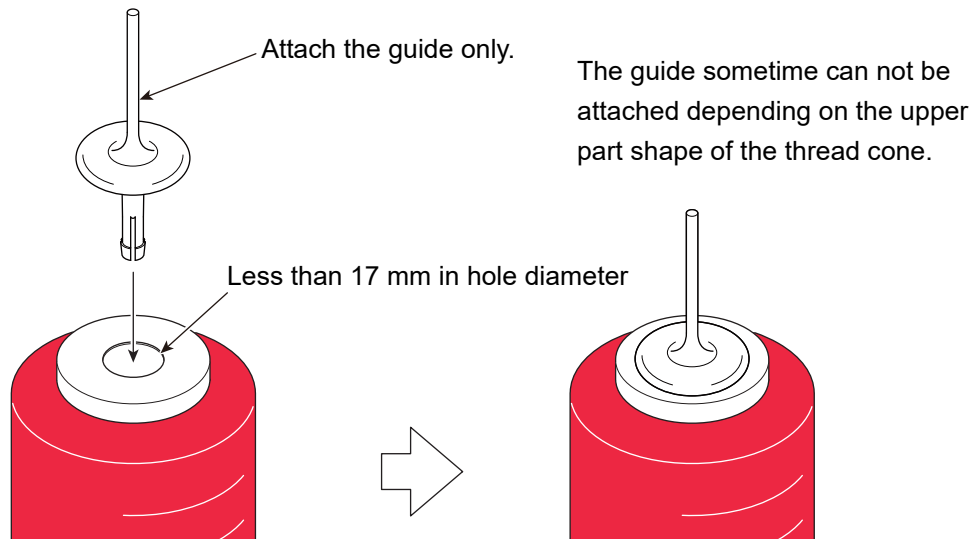

(3) Put B set on the guide.

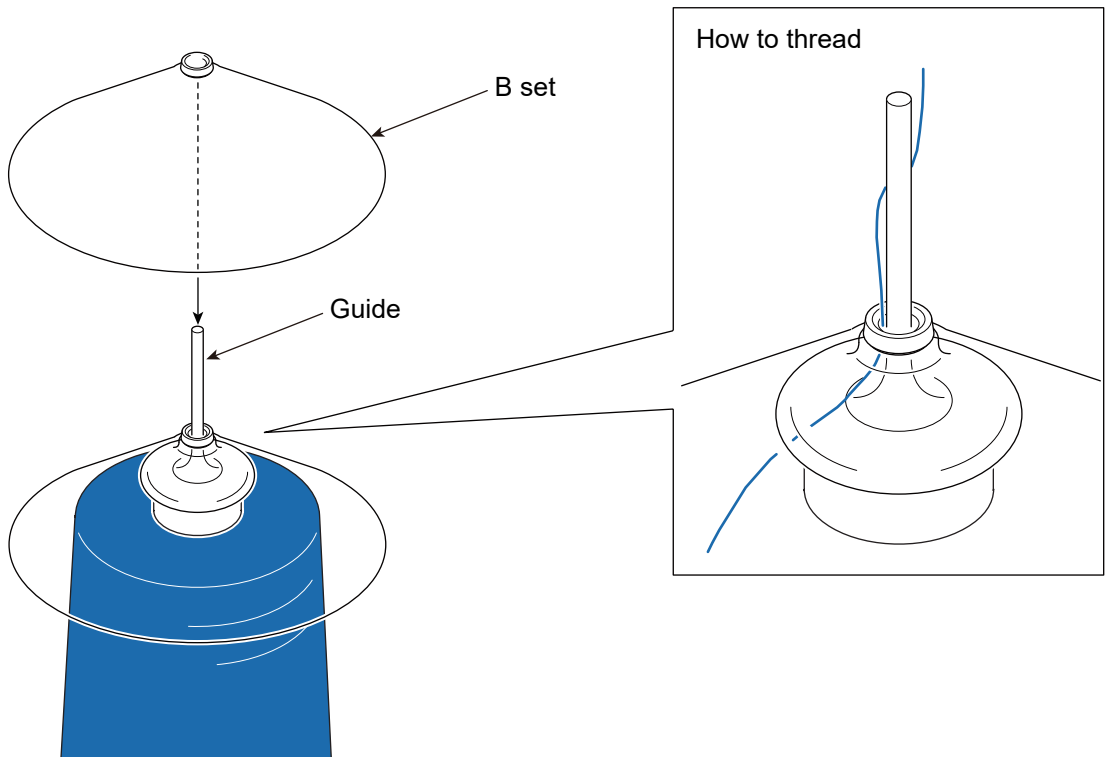

- (4) When the height of thread cones next to each other are the same, B sets interfere with each other. Therefore, add to put the felt under either one thread cone as shown in the photo below.

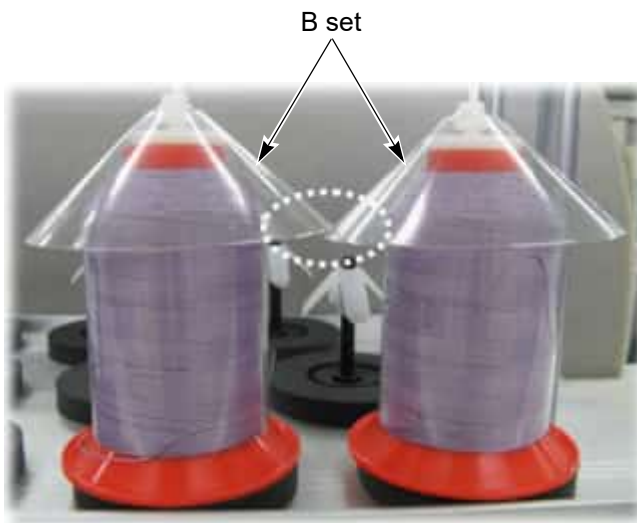

Attach or detach B set carefully.

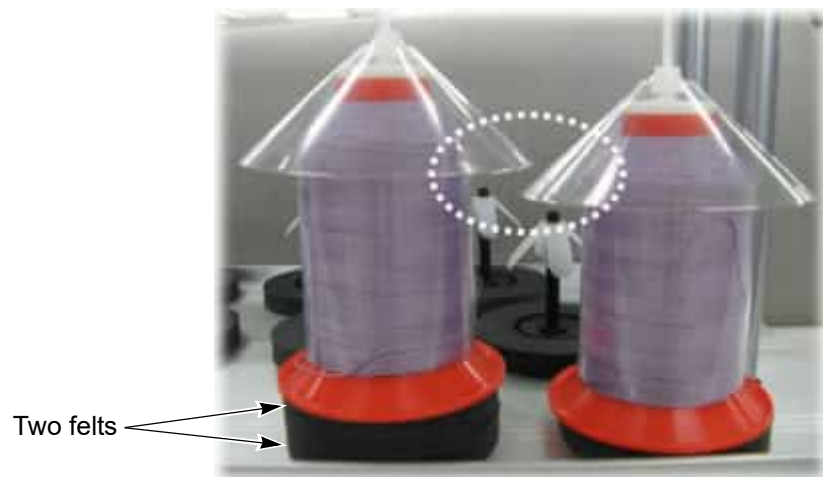

3-2. To thread (PAX, HAR)

If the thread does not pass to each section correctly, it could cause trouble such as the deterioration of product or the thread breakage, etc. Pass the thread correctly referring to the figure below.

- (1) Place the thread cone on the thread stand blade.
- (2) Pass the thread through the thread course.
- (3) Thread into grooves (indicated by arrows) of the first tension and the second tension.

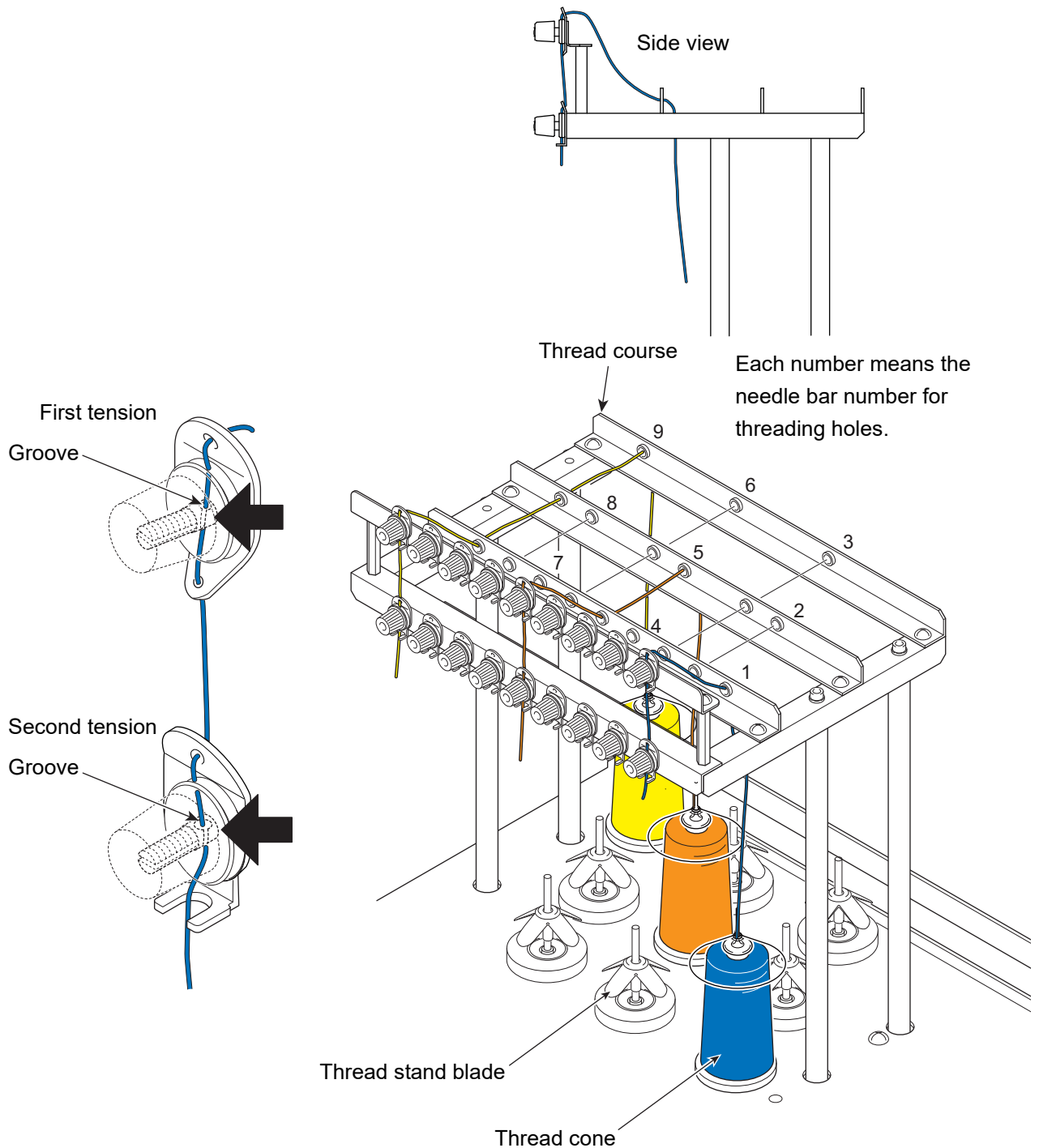

- (4) To perform threading through the spiral tube, use the threader (accessory).
- (5) Thread into the groove (indicated by an arrow) of the third tension.

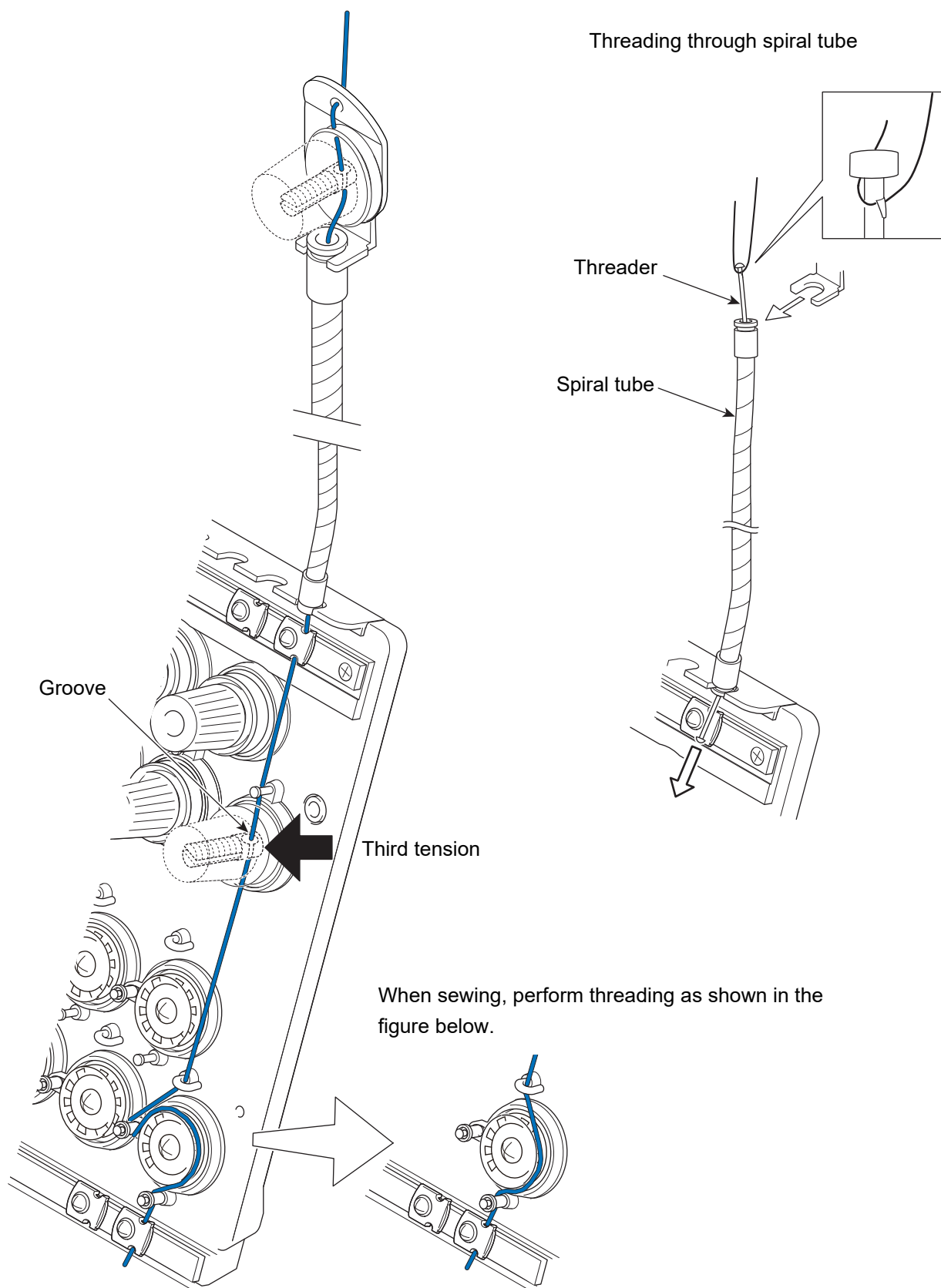

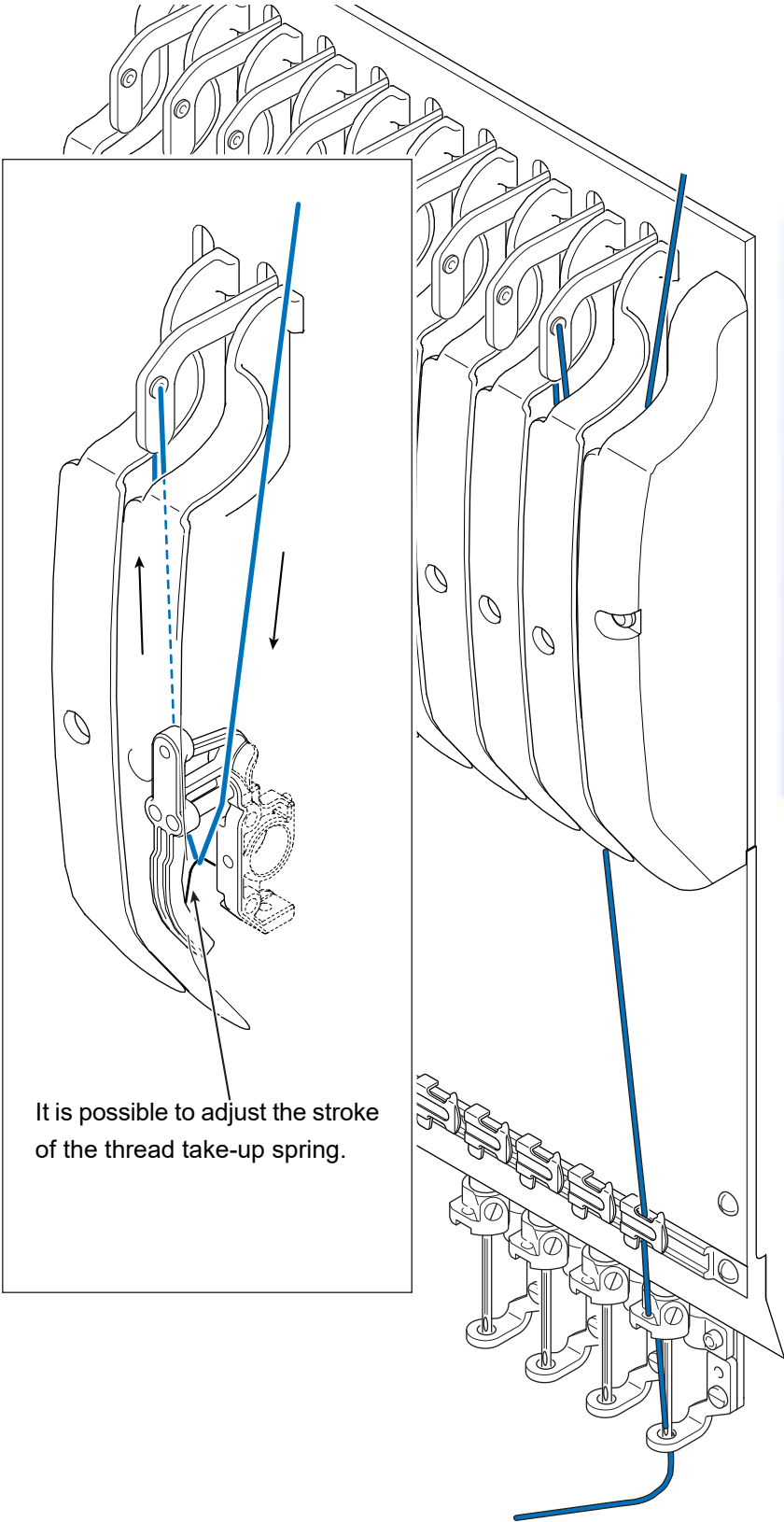

It is possible to adjust the stroke of the thread take-up spring.



It is possible to perform threading easily by just hooking the thread here. (One-touch middle thread guide)

3-3. Test sewing

CAUTION

- ! Use the machine with about 70% of the maximum speed as "Operation for total fitting" for about one week after installing this machine. By performing operation for total fitting, life of the machine will become longer, which will be useful to avoid unexpected troubles.

[For H head]

Stretch fabric on the frame, set under thread bobbin and check each movement such as color change, manual ATH, etc. Then, start test sewing.

[For P head]

For the parts surrounding the frame to fix the leather, prepare at distributor or your side.

The photo below is an example when fixing the leather to the border frame sash by using the placement sewing sheet.

- Use plastic sheet (PP sheet) (standard spec.)

Attach the plastic sheet (PP sheet) to the frame, and put the leather on it, then perform punching.

For the plastic sheet (PP sheet), refer to the user's manual of the machine.

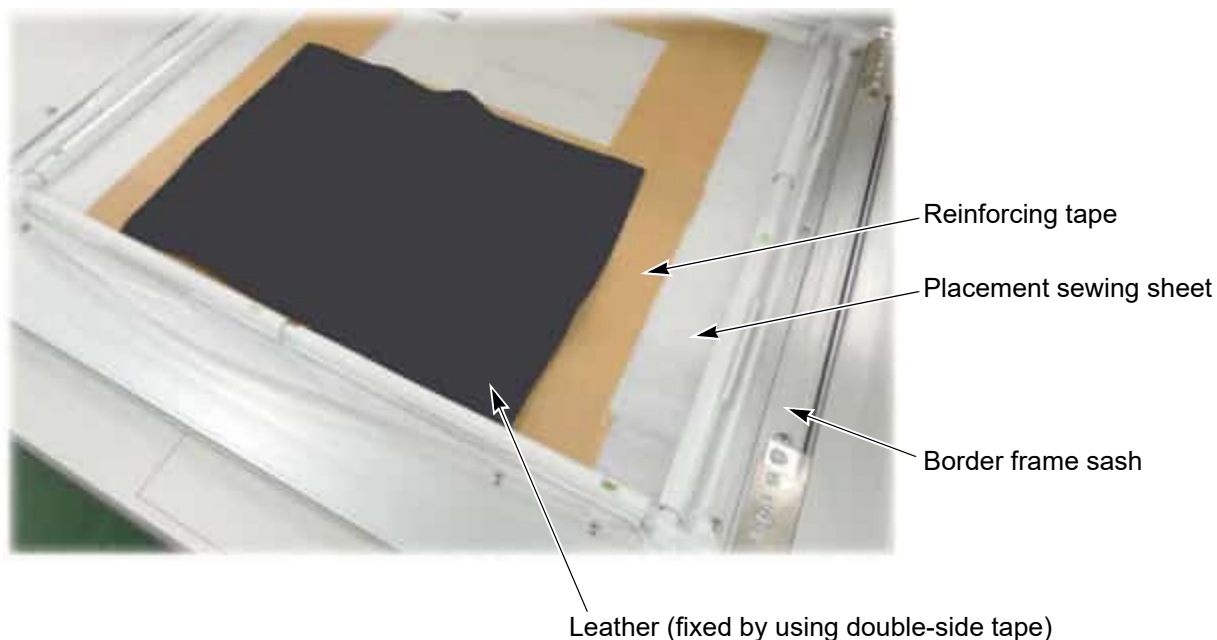

- Use the auto. PP tape feeder (option)

Check that the PP tape is correctly led through the specified portions before perforating.

If one of the following occurs, the machine stops with code number 237-01 displayed. Take the specified corrective action to restore the machine.

Stop factor	How to restore
Tension of PP tape is weak.	Adjust tension.
Running out of PP tape material	Install PP tape.
PP tape supply error (tape stuck, etc.)	Check that the PP tape is led through the correct portions.

[If you cannot satisfactorily perforate leather due to a problem relating to the lower dead point of the perforator needle]

Add another plain washer (0.1 mm) to between the perforator needle and the needle clamp where a plain washer (0.1 mm) is preinstalled at shipment.

Or if the perforator needle goes through the plastic sheet (PP sheet), remove the plain washer (0.1 mm).

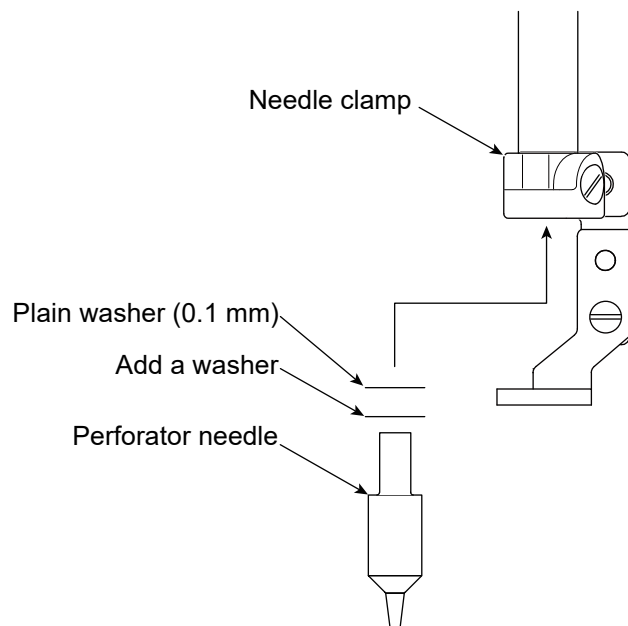

1st Edition May, 2015

10th Edition April, 2022

■ **Manufactured by : TISM Co.,Ltd.**

Address : NO.1800, Ushiyama-cho, Kasugai, Aichi-pref., 486-0901, Japan

TEL : 81-568-33-1161 FAX : 81-568-33-1191

■ **Distributed by : Tajima Industries Ltd.**

Address : NO.1800, Ushiyama-cho, Kasugai, Aichi-pref., 486-0901, Japan

TEL : 81-568-37-1130 FAX : 81-568-37-1230

●**Copy, reprint, or reform of a part or whole of this manual without permission is prohibited.**