



ENGINEER'S MANUAL

Machine Setup Instructions

Manual for machine setup instructions

TMEZ-KC

Foreword

This is a setup manual for TMEZ-KC.

It is a document for engineers performing the after-sales service of machines.

Be sure to understand the necessary parts, procedure, and precautions through this manual when setting up the machine.

Safety precautions

To prevent any harm or damage to those who use this product or other people, we describe items that must be surely followed as below.



Indicates that there is a lot of danger of death or serious injuries [*1] if handled by mistake.



Indicates that there is a likelihood of death or serious injuries [*1] if handled by mistake.





Indicates a potentially hazardous situation which may result in minor or moderate injury [*2] or property damage if handled by mistake.

*1: A condition caused by electric shock, injury, fracture of a bone, etc., that leads to aftereffects, or an injury that necessitates hospitalization or visits to a hospital over a long period.

*2: An injury that does not necessitate hospitalization or visit to a hospital over a long period.

: Prohibited items

: Items that may cause electric shock if not observed

: Items that must be followed carefully to ensure safe operation

User's Manual / Parts List

User's manual / Parts list are stored as the PDF file in the accessory DVD.

Please read the contents thoroughly and then use the machine or the optional device.

To see the PDF file, "Adobe Acrobat Reader" is necessary.

User's manual, parts list of the optional devices you have not purchased are also included in this DVD.

Please note beforehand.

[How to open the DVD]

- 1 Insert a DVD into the personal computer.



Since the following pop-up window will be displayed automatically, select "Open folder to view files" (indicated by the arrow).



- 2 Double-click left "titlepage".

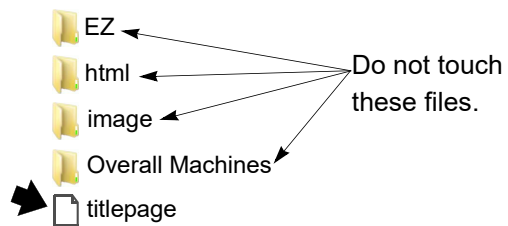

- 3 Select displaying language.

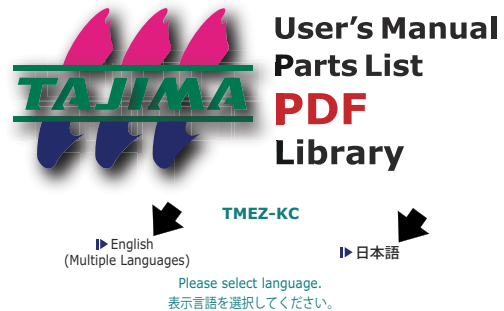

- 4 Select "User's Manual" or "Parts List", and then select the title you desire.

English	Title	Dated	Category
Chinese	FOR SAFE USE (EMBROIDERY MACHINES)	Jul 2020	Safety
Korean	01_BASICS (EMBROIDERY MACHINES)	Jul 2020	Embroidery machine
Spanish	02_BASIC OPERATION (TMEZ-KC)	Jul 2020	Embroidery machine
Portuguese	03_ADVANCED OPERATION (TMEZ-KC)	Jul 2020	Embroidery machine
Italian	04_PARAMETER SETTING (TMEZ-KC)	Jul 2020	Embroidery machine
German	05_FRAME CHANGE (TMEZ-KC)	Jul 2020	Embroidery machine
Russian	QUICK REFERENCE FOR TMEZ, TMCR (I-TM)	Jul 2020	Embroidery machine
Czech			

The figure above is an example selecting "English (Multiple Languages)" in the above 3.



MUST DO LIST AT MACHINE INSTALLATION

MODEL:	M/NO.:
	DATE / / / PIC:

Check the following items in order after “Chapter 4 Level adjustment”.

Chapter 5 Adjustments	Remarks	✓
1. Needle locating position	Check and adjust the needle locating position. <ul style="list-style-type: none"> The 1st needle on all heads The last needle on all heads Equalize it at the 1st needle and the last needle.	✓
2. Lower dead point	Check and adjust the lower dead point.	✓
3. Upper dead point	Check and adjust the upper dead point.	✓
4. Bevel gear	Check and adjust bevel gears gap in front/rear, left/right direction.	✓
5. Needle and rotary hook	Check and adjust the needle and the rotary hook timing and the gap.	✓

Chapter 6 Idling and test sewing	Remarks	✓
1. Lubrication	Lubricate to the rotary hook and the inside of the arm.	✓
2. Idling, jump	Run the machine at least 20 minutes without threads for all needles to remove anti-rust liquid from the rotary hook.	✓
	Check if the reciprocator catches the needle bar stud at inching.	✓
	Check if the jump device operates properly.	✓
3. Threading	Pass thread correctly.	✓
4. Test sewing	Check if the thread breakage or the needle breakage occurs.	✓

Chapter 1 Carrying

1. Installation environment	1
2. How to carry	2

Chapter 2 Installation

1. Machine stand section	4
1-1. Attaching casters	4
1-2. Attaching leveling bolts	4
2. Detaching	5
2-1. Stopper	5
3. Attaching	5
3-1. Thread course	5
3-2. Operation panel	6
3-3. Beam sensor (limited model)	6

Chapter 3 Connection of power cord

1. Important safety instructions	7
2. Power cord	9
3. Parameter setting	9

Chapter 4 Level adjustment

1. Level adjustment	10
2. Attaching center support	11

Chapter 5 Adjustments

1. Needle locating position	12
2. Lower dead point	14
3. Upper dead point	17
4. Bevel gear	17
5. Needle and rotary hook	18

Chapter 6 Idling and test sewing

1. Lubrication	19
1-1. Rotary hook	19
1-2. Inside of arm and cylinder bed	20
2. Idling, jump	21
3. Threading	22
4. Test sewing	24

Chapter 1 Carrying

1. Installation environment

! CAUTION

- ! Install the machine on a sturdy floor.

The floor structure must be strong enough to bear the machine weight (indicated on the spec. plate). If the floor is supported by steel frames, place the machine stand on the steel beams as much as possible.

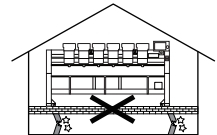

- ! Control the operation noise in the environment.

This machine is designed to reduce noise during operation. To improve the sound insulation performance in the factory still more, use the interior finish materials which show high sound insulating performance for the walls, ceiling, and floor of the factory.

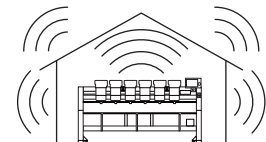

- ⊘ Avoid direct sunlight.

If the machine is exposed to direct sunlight over an extended period of time, the machine body may be discolored or deformed. Put curtains or shades to prevent the machine from direct sunlight.

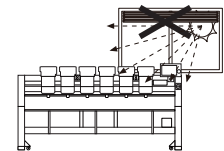

- ! Provide enough space for maintenance.

Taking account of operability when maintaining and inspecting the machine, provide working space of 50 cm or more to right and left, and 50 cm or more to rear directions for the machine against obstacles such as walls.

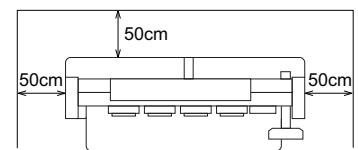

- ! Avoid dust and moisture.

Since dust and moisture lead to dirt and rust on the machine, use the machine in an air-conditioned environment, and clean the working place periodically. Use caution not to expose the machine to direct wind from the air conditioner so that the embroidery threads do not become disheveled.

Degree of pollution: 2 or less

Humidity: 30 to 95%RH (relative humidity) without condensation

Ambient temperature: 5 to 40°C (during operation), -10 to 60°C (during storage)

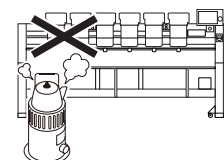

CAUTION

- ! Pay attention to interference of radio wave.

Although the machine is designed not to apply radio wave to other equipment, there could be cases where it causes radio wave interference depending on the operating environment and type of equipment to be used. If such problems arise, install the equipment as apart from the machine as possible.

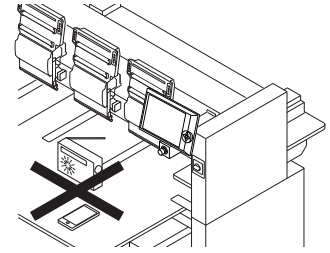

- ! Pay attention to power supply style.

When supplying the power, meet the following requirement.

- Excess voltage category: III

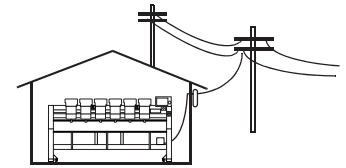

- ⊘ Do not use the machine in such a place where a strong electric field or magnetic field occurs by such a high-frequency welder of large output power.

2. How to carry

DANGER

- ! When suspending (lifting) the machine, make sure that there is no person standing in the danger area around the machine, especially under the machine.

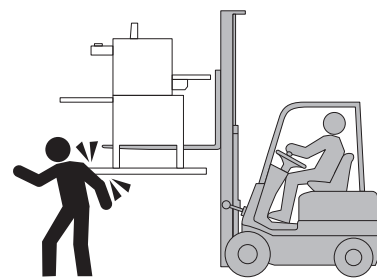
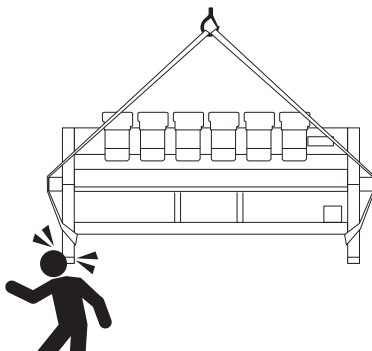

! WARNING

- ! When suspending the machine, use the square lumbers as shown in the figure below, and make sure that the nylon sling does not touch the table. (section A)

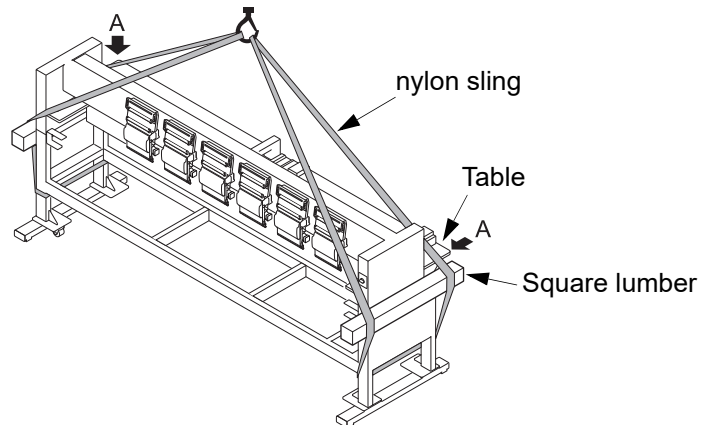

- ! When suspending the machine, use a nylon sling that is long enough to provide a sling angle of 50° or more.

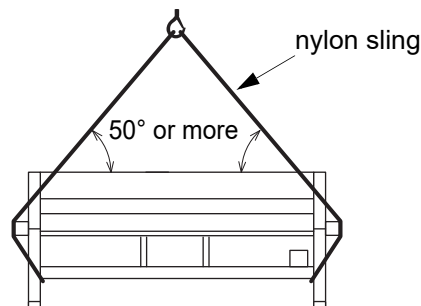

- ! When using a forklift, pay attention to "Gravity center mark" that indicates the center of right and left balance of the machine.

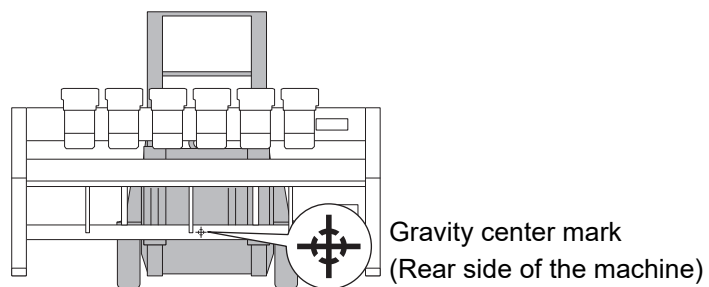

Chapter 2 Installation

1. Machine stand section

1-1. Attaching casters

1 Attach caster 1 to machine stand with screws 2.

[2H-500P, 4H-360P]

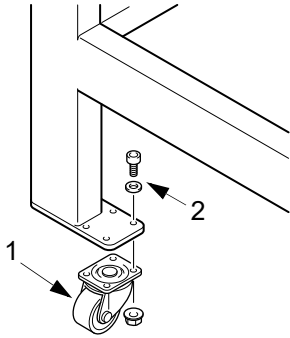

[4H-500P, 6H, 8H]

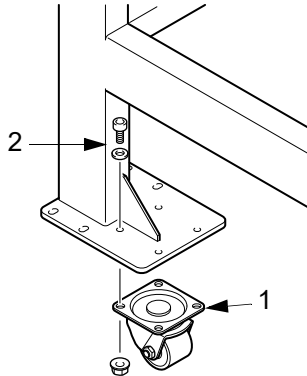

1-2. Attaching leveling bolts

[2H-500P, 4H-360P]

Attach leveling bolt 1 and leveling block 2 to machine stand, and place vibration-preventive base 3.

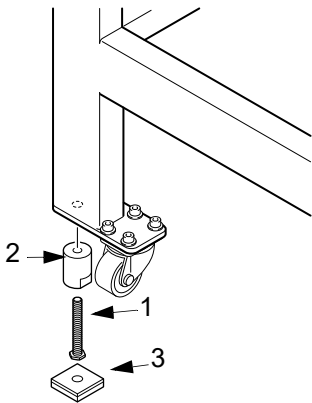

[4H-500P or larger size models]

Attach stand base 4 to machine stand with screws 5. Attach leveling bolt 1 to the stand base 4, and place vibration-preventive base 3.

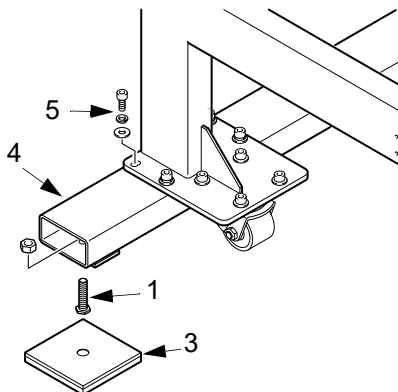

2. Detaching

2-1. Stopper

The attaching positions of stoppers 1 differ depending on the number of heads.

- 1 Remove screw 2 and detach all stoppers 1.

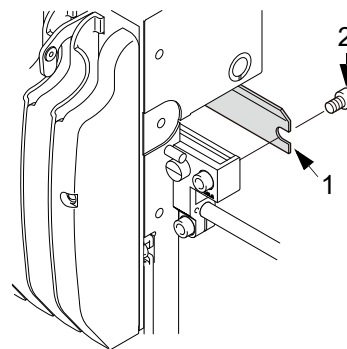
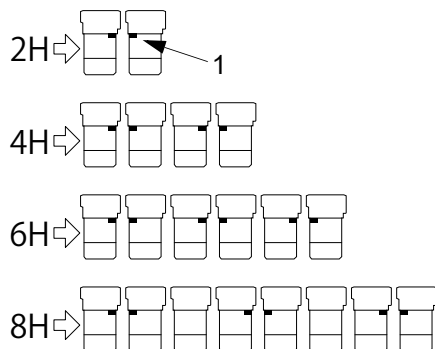

CAUTION

- Do not turn the knob of the change box manually to change colors even after detaching the stoppers.

The i-lever may be damaged if you slide the needle bar case before the i-lever returns to the retracting position. Do not turn the knob manually to change colors before turning on the power.

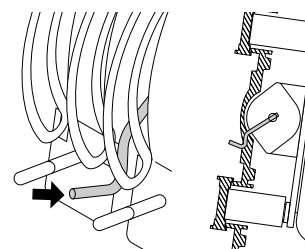

3. Attaching

3-1. Thread course

- 1 Attach thread guide system support bars 2 to the thread stand plate 1 and attach thread guide 3 with screws 4.
- 2 Attach felt 6 and thread stand blade 7 to thread stand stud 5.

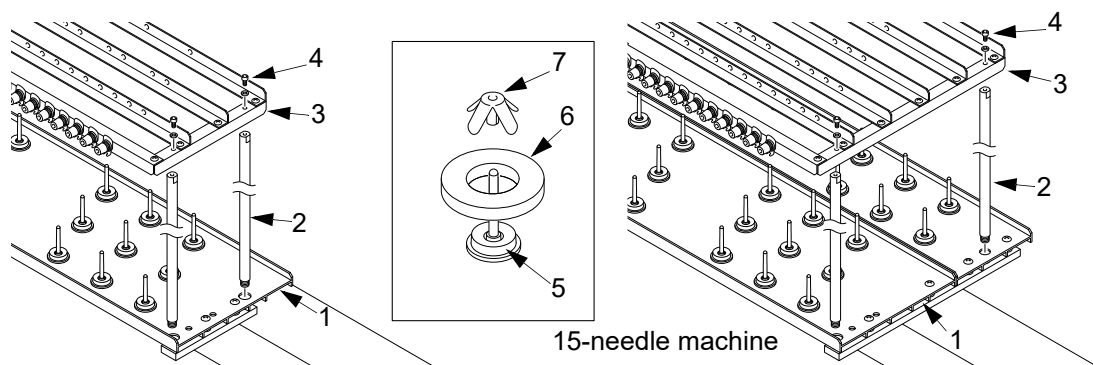

3-2. Operation panel

- 1 Loosen knobbed screw 1 and attach operation panel 2 to the pipe 3.
- 2 Connect LAN cable 4, USB cable 5, and power supply cable 6 to CN2701, CN2101, and CN4101, respectively.

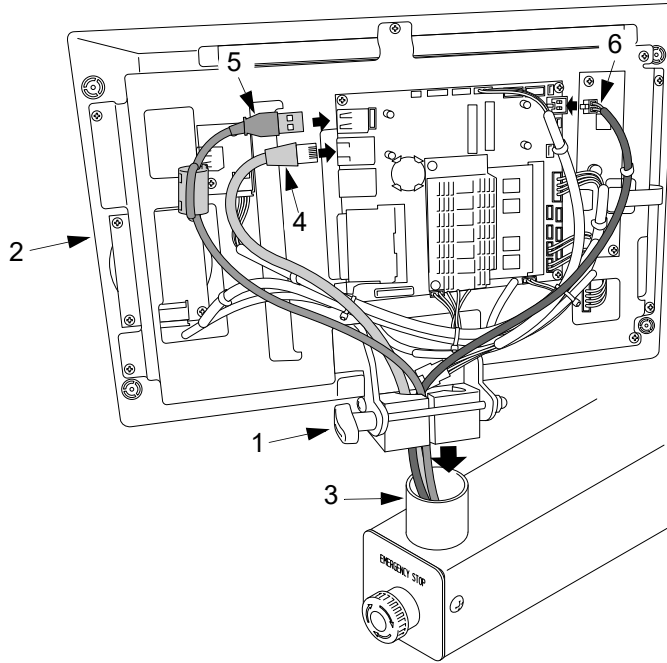

3-3. Beam sensor (limited model)

The presence or absence of a beam sensor depends on the specifications.

- 1 Attach reflector 1 and beam sensor 2 with screws 3 (M4*8).
- 2 The reflector and the beam sensor are 94 mm and 70 mm high, respectively, from the table.

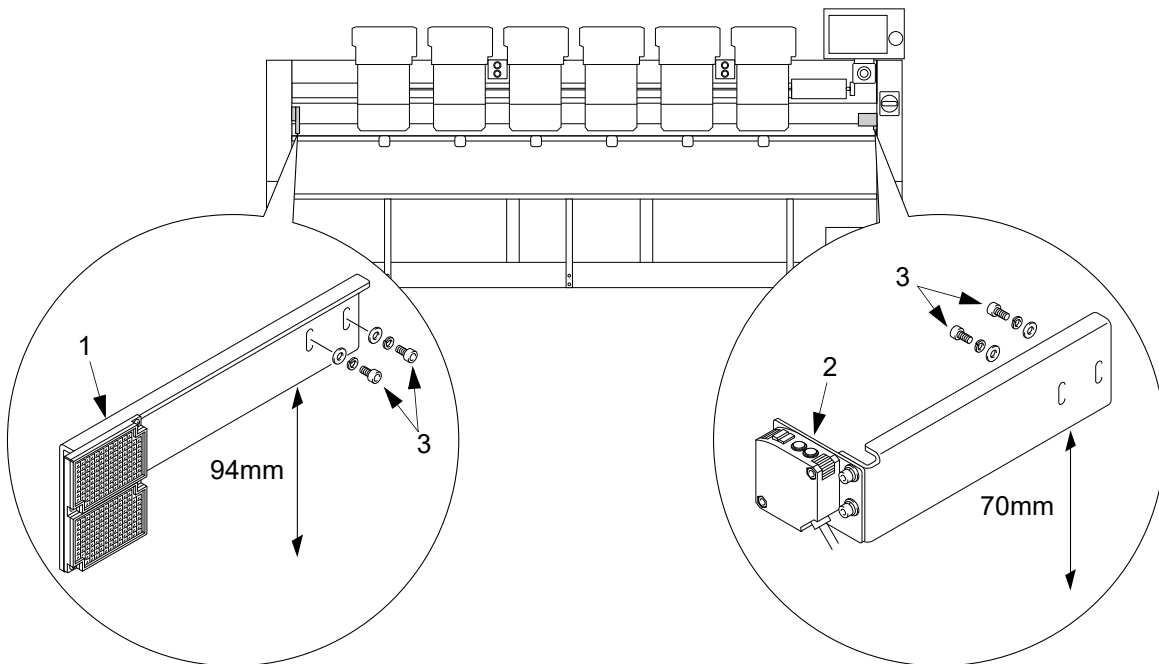



Chapter 3 Connection of power cord

1. Important safety instructions



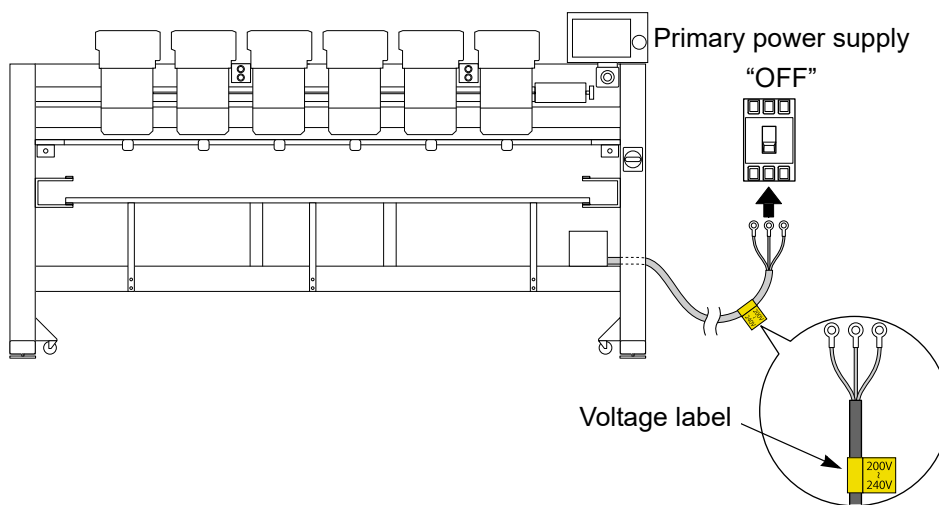

DANGER

-  Turn OFF the primary power supply when you connect the power cord. There could be danger of electric shock, burn, or death. In addition, check if the voltage of the voltage indicating label that is attached to the power cord fits voltage spec. on your side, and then connect the power cord to the primary power supply.



-  If the machine needs to be connected to an external power supply, the power supply cable connection must be done only by the service personnel assigned and trained by TAJIMA or qualified technician.

WARNING

-  When supplying the power, conform to excess voltage category "III".
-  Connect the machine to the power supply line that is not connected to machines subject to large load fluctuations such as elevators and presses so that the machine can operate in stable conditions.
-  Check if power voltage is enough for operating the machine by using a multimeter.
Voltage: Within $\pm 10\%$ of the rated voltage
-  The power supply cable must be laid out of the operator's moving area so that the operator does not step on the cable.

⚠ WARNING

- ⚠ Insert the power cable plug fully. If a metallic part etc. touches a blade in the plug, it may cause fire and/or electric shock.
- ⚠ Since there is danger of electric shock due to leak current, be sure to connect the grounding wire of the machine. Degree of grounding should be type D or higher (grounding resistance 100 ohms or less).

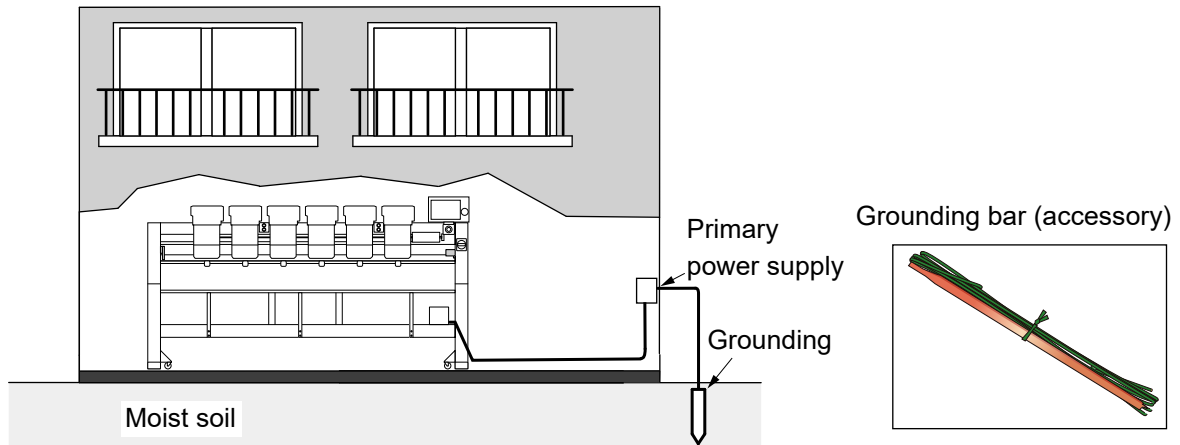

⚠ CAUTION

- ⚠ In addition to full-time leak current, leak current generated by harmonics and surge flows in the power cable of the machine. For this reason, if the selection and installation of the earth leakage circuit breaker and leak current relay used for the factory are not correct, the malfunctioning of the machine may occur.
Regarding the connection of power cord, observe the following items.
- ⚠ Use an earth leakage circuit breaker and leak current relay for which measures are taken against harmonics and surge. If such a breaker and a relay are not available, select conventional breaker and relay with sufficient leak current capacity to absorb leak current caused by harmonics and surge. (In this case, constant leak current must be controlled satisfactorily.)
- ⚠ Regarding the capacity of the earth leakage circuit breaker and leak current relay required per machine, please consult your local TAJIMA distributor.
- ⚠ For the model names of the earth leakage circuit breaker and leak current relay for which measures are taken against harmonics and surge, please consult your local TAJIMA distributor or electric engineers.
- ⚠ To prevent the machine from property damages, one embroidery machine should be connected to one no-fuse breaker. Property damages include a drop of the output of the main shaft motor, the stop position error, color change error, design displacement, etc.

2. Power cord

The following types of power cords are available.

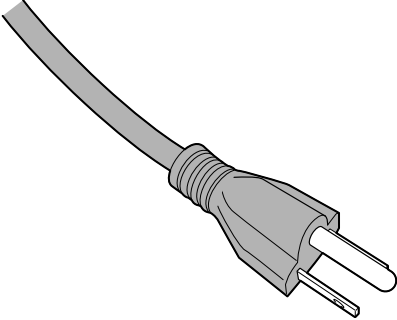
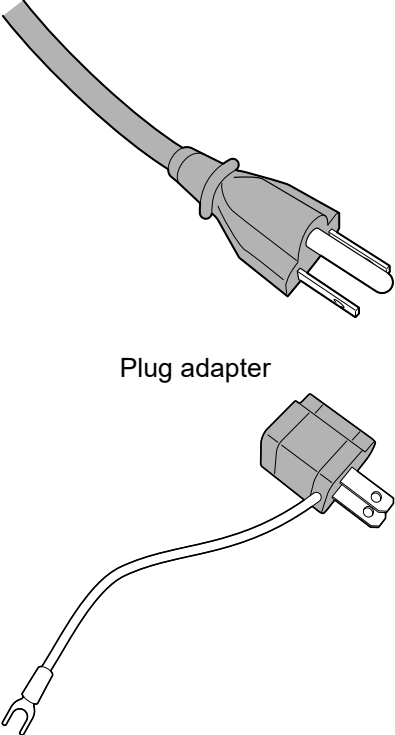
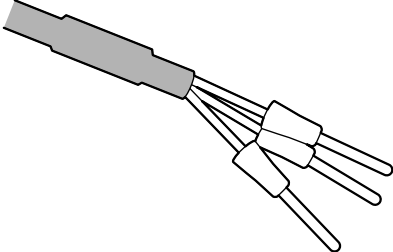
Exclusive item for UL-spec.	For use in Japan	Other than the left
	 <p data-bbox="735 808 890 837">Plug adapter</p>	

3. Parameter setting

A parameter chart is attached to the back of the operation panel. Check setting values. At this moment, also check the version of the software.

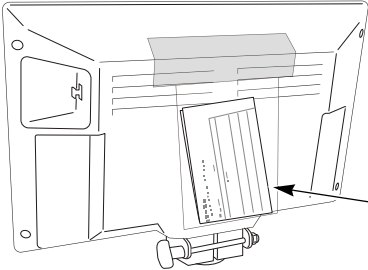

Regarding information about the latest version of the software and how to obtain the software, consult the distributor.

“Parameter setting chart” at shipment from the factory is attached.

Chapter 4 Level adjustment

1. Level adjustment

1 Place level gauges 1 on the square pipe and check on the right and left sides that both sides are leveled.

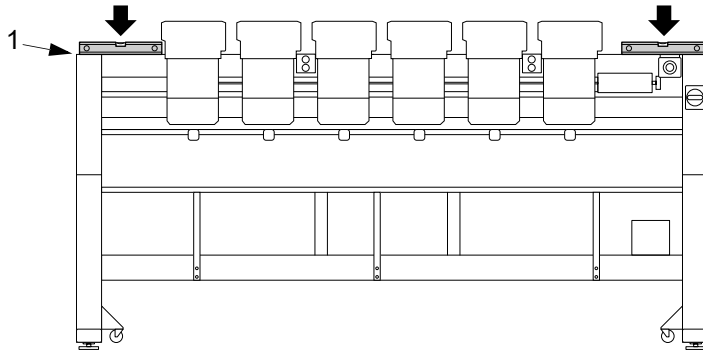

2 To level out the front and back, attach magnet holder 3 so that the corner of magnet holder 3 will come in contact with the center of punch mark 2 on the side of the machine.

3 Place level gauge 1 on magnet holder 3 and check the level on the right and left sides.

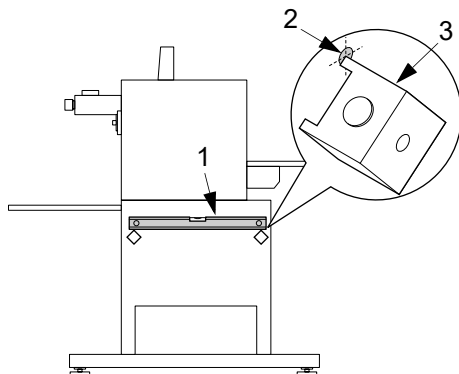

4 Adjust diagonally located leveling bolts 1 with the level gauge.

After adjusting the leveling bolts 2, secure with the leveling block 3 or nut 4.

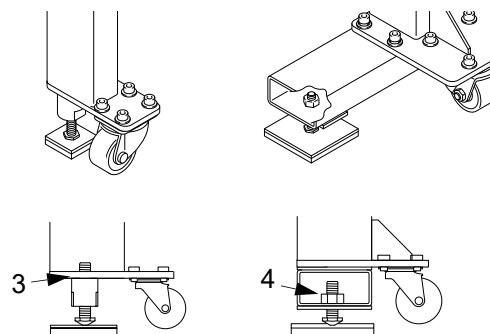
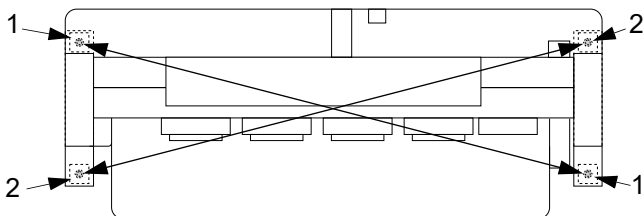

2. Attaching center support

Applicable models: 6H-500P, 8H-360P

- 1 Place vibration-preventive base 2 in front of and behind the center of the machine, and then set center support 1.
 - 2 Adjust the height with adjusting screw 3 and secure with the nut 4.
-  Raising the center support in excess affects the needle bar lower dead point and needle locating position.

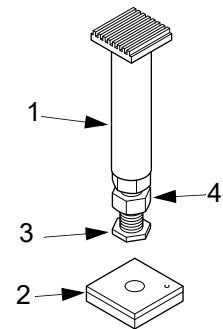
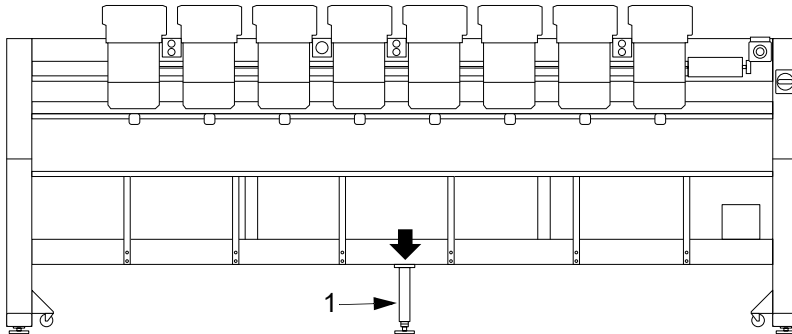

Chapter 5 Adjustments

1. Needle locating position

Perform this checking at the first needle and the last needle.

- 1 Press the switch D on the tension base once to lower the presser foot to the middle position.

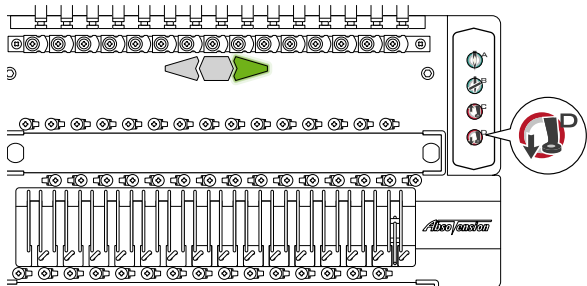

- 2 Set parameter "85. Machine Adjustment: 9. Main Shaft Brake" to "No".

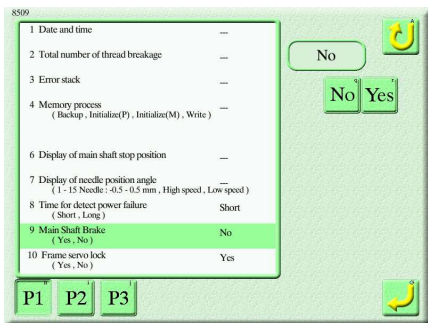

 There is no need to release the main shaft brake if the main shaft motor has not moved at all since the power supply was turned on.

- 3 Turn the main shaft counterclockwise to set the main shaft angle to 178° (Needle bar lower dead point).

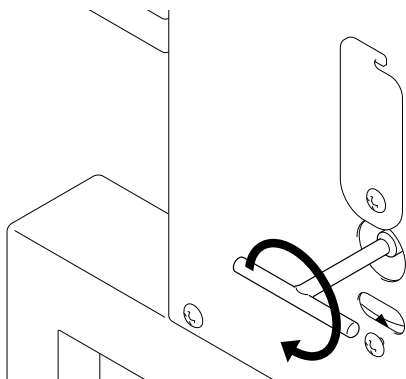

- 4 Lower the needle bar by hand.

- 5 Check if the needle is almost located at the center of the needle hole.

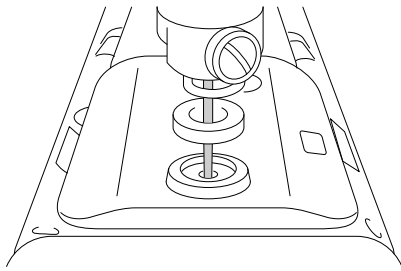

- 6 Return the main shaft angle clockwise to 100° (Stop position).

- 7 Perform Color Change to the last needle to check the needle locating position.

- 8 Set "2 Main Shaft Brake" to "YES" after confirming.

☐ When the needle locating position is not in the center.

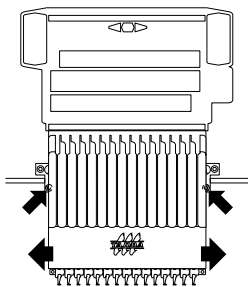

- For the head that needs adjustments, loosen the screw (as shown with the arrow in the figure on the left-hand side) that secures the needle bar case and redistribute the needle bar case so that the first and last needle locations will be properly balanced.
- Adjust the position of the i-lever of the i-TM tension base for the head of which the needle location adjustments finished.

2. Lower dead point

Perform this adjustment from the 1st needle to the last needle (All needle bars).

- 1 Set the main shaft angle to 178° (needle bar lower dead point) with the main shaft handle.
- 2 Push down the needle bar with your finger and loosen screw 1.

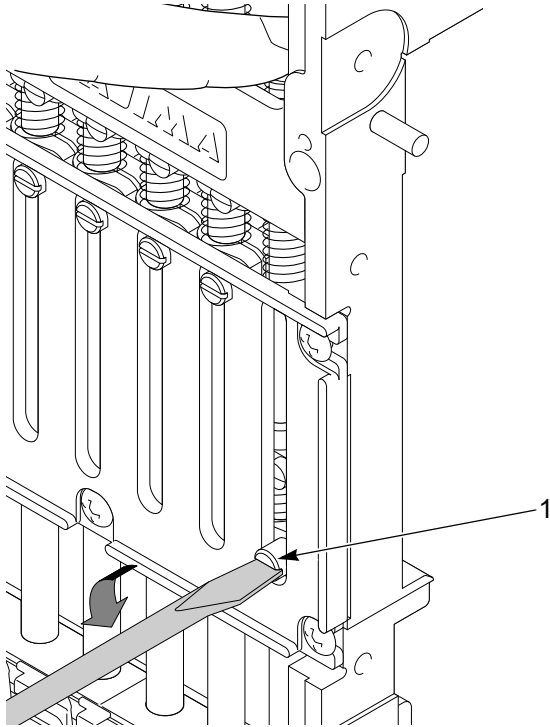

- 3 Attach lower dead point gauge 2 so that the needle comes into groove 3.

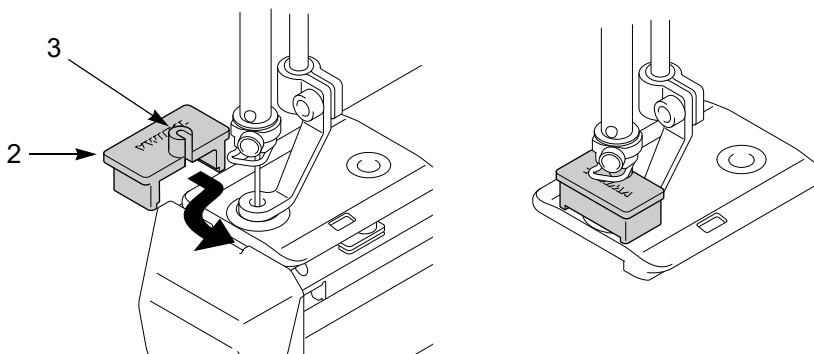

- 4 Push down the needle bar 4 to come in contact with the lower dead point gauge 2, and then tighten the screw 1.
- 📖 Set the needle clamp 5 so that the position viewed from the front will be oriented to the direction as shown in photo A.

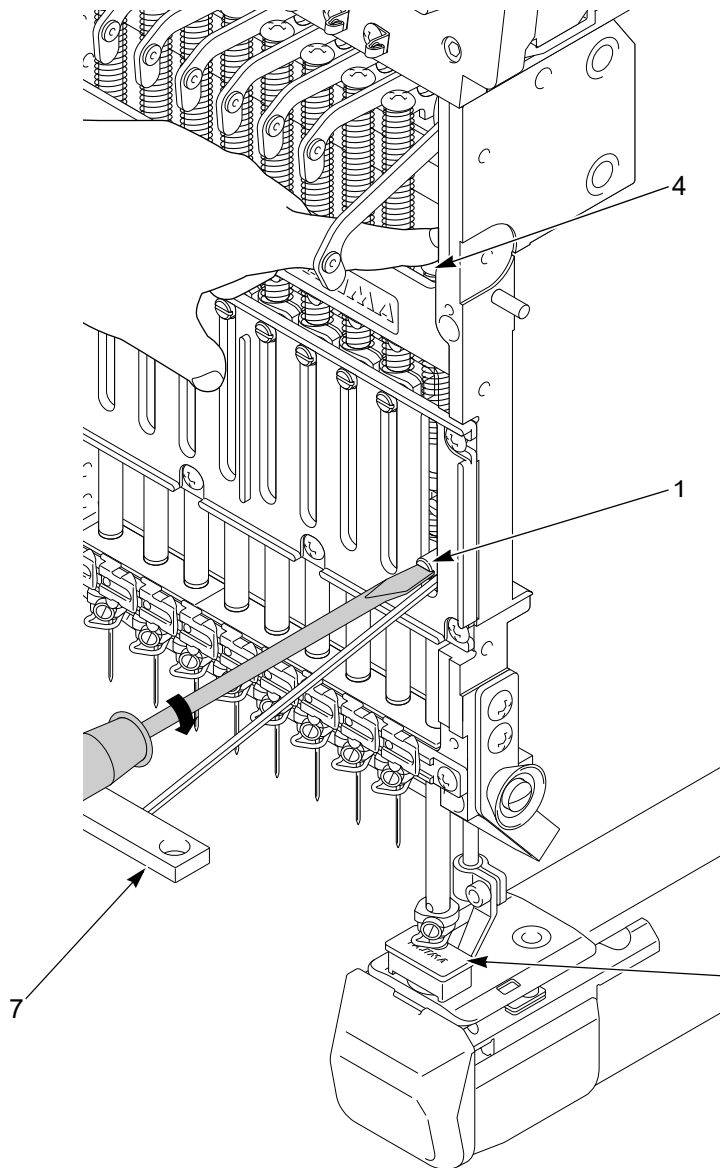

Tighten screw 1 in the state that needle clamp 6 is raised shown in the figure below. In this example, wrench 7 is used.

Viewing from side

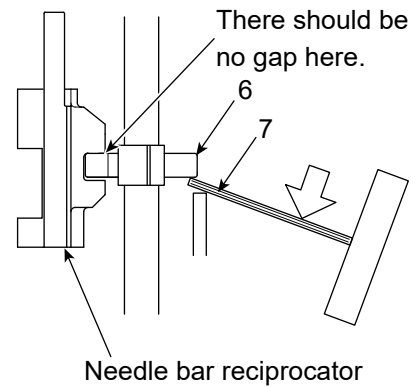
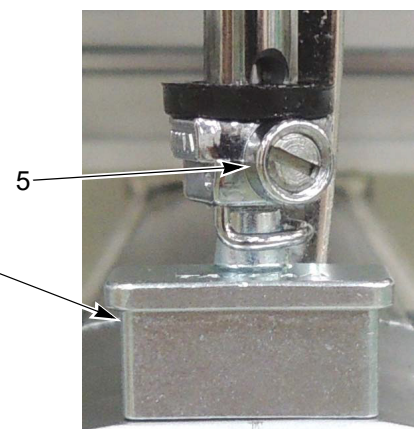

Photo A



- 5 Detach lower dead point gauge 2.
- 6 Set the main shaft angle to 100° (Stop position).
- 7 Perform Color Change to the next needle bar.

8 Attach GAUGE: NEEDLE CLAMP 8 to the needle bar for the first needle.

9 Loosen wing screw 9 and then tighten wing screw 9 with no gap between sections A and B.

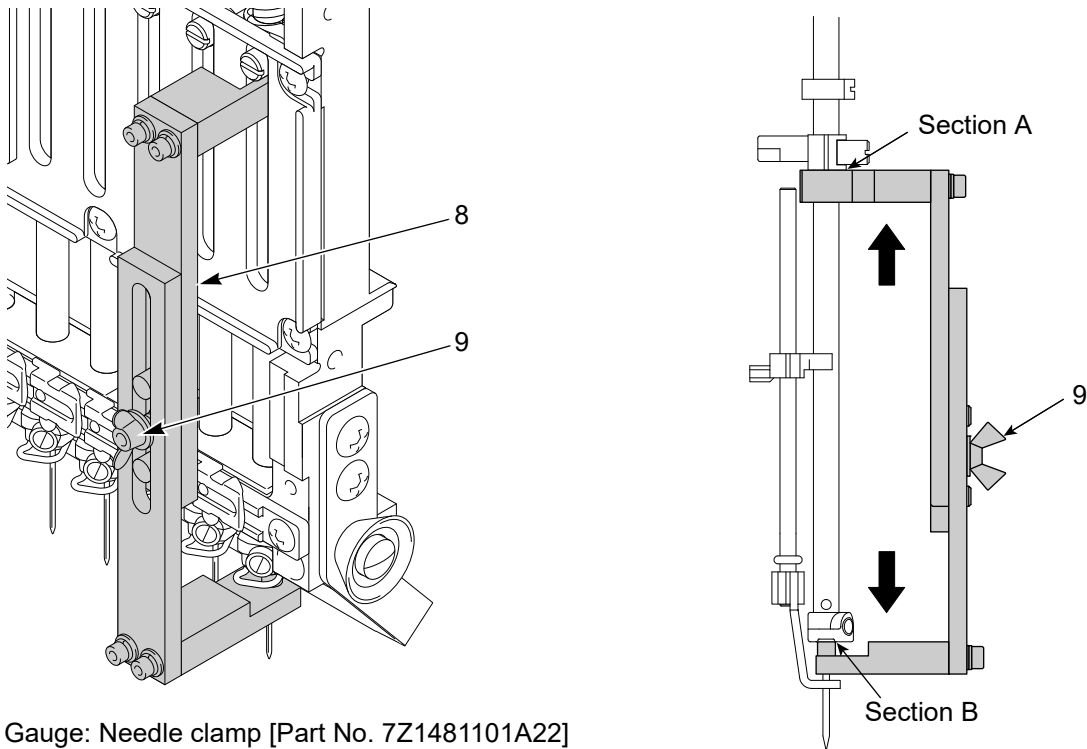

10 Attach GAUGE: NEEDLE CLAMP 8 to the needle bar for the second needle.

11 Loosen screw 10 and then tighten screw 10 with no gap between sections A and B.

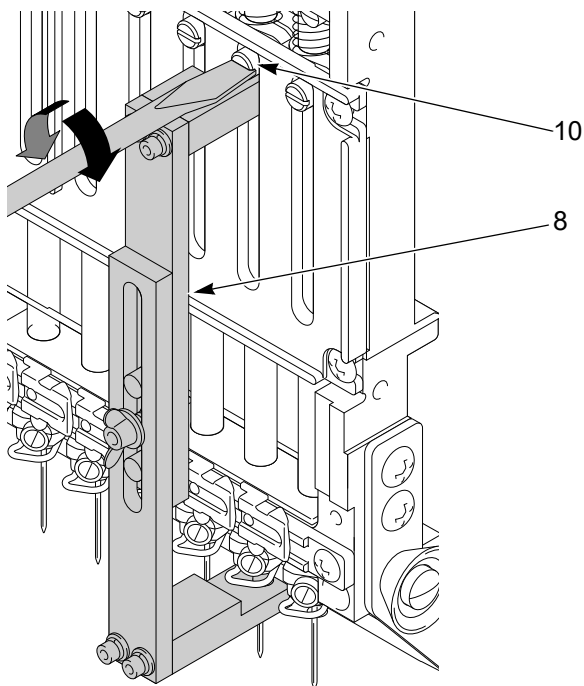

12 Perform working to the last needle.

3. Upper dead point

- 1 Set the main shaft angle to 0° (Upper dead point).
- 2 Loosen screw 2 of upper dead point stopper 1, and tighten it again with screw 2 facing the front. (1 or 2 in figure A below).

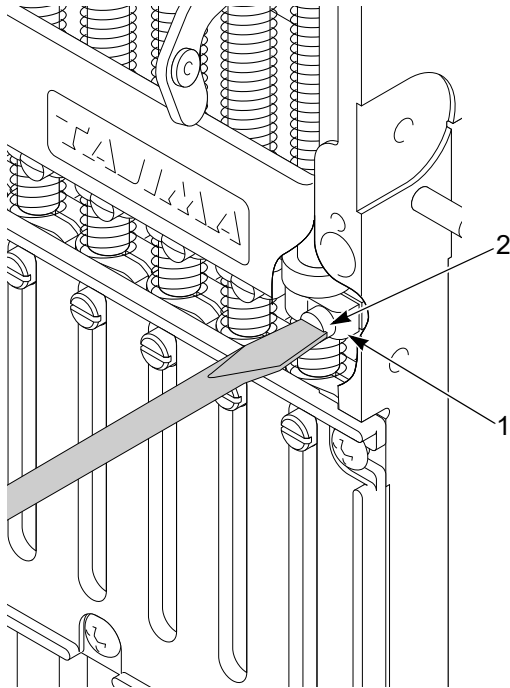
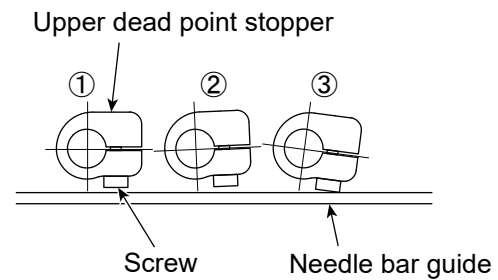
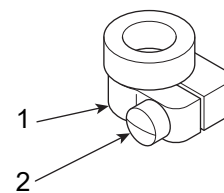

Fig.A Viewing from top



In the state of ③ in figure A above, the upper dead point stopper touches the needle bar guide, which may cause damage to or failures in parts.



4. Bevel gear

Check the play between bevel gear 1 and bevel gear 2. If bevel gear 2 moves slightly (0.1 to 0.2 mm), the play is normal.

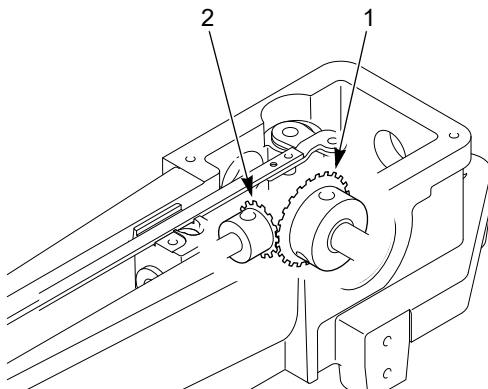

If there is no play, loosen the set screw of bevel gear 1 to adjust the position of bevel gear 1.

5. Needle and rotary hook

Perform this checking at the first needle and the last needle.

- 1 Detach the needle plate.
- 2 Lower the needle to the lower dead point in the same way as that for “Chapter 1. Needle locating position”. See page 12.
- 3 Turn the main shaft counterclockwise and set it to the position (198° to 202°) where the needle tip 1 meets the hook point of rotary hook 2.
- 4 Check if the clearance (A) between the scarf of the needle 3 and the hook point of rotary hook 2 is 0.1 to 0.3 mm.

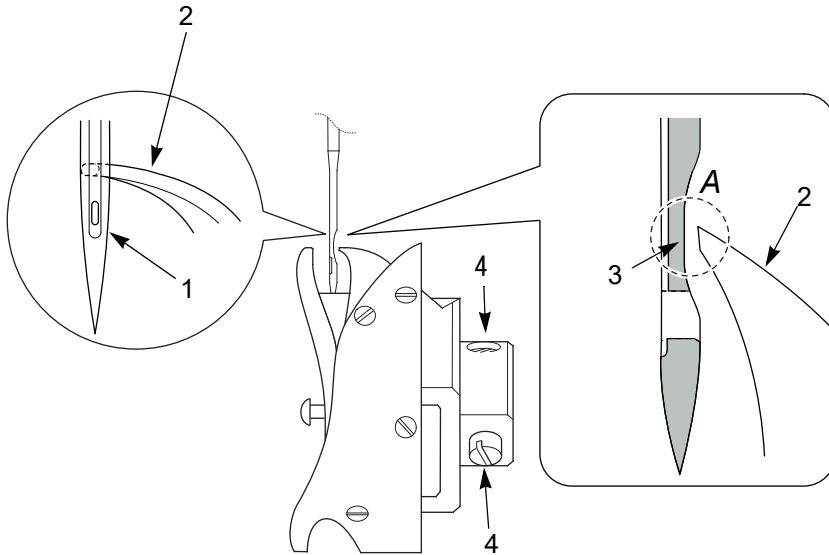

- 5 Loosen the screw 4 at each of the three points, and then adjust the position of the rotary hook if the clearance (A) is outside the reference range.

Chapter 6 Idling and test sewing

1. Lubrication

! CAUTION

- ! When performing lubrication, use only TAJIMA genuine TF oil (provided in the same package with the machine). If you need to use other oil for some reason, select oil equivalent to ISO viscosity grade: VG20.
- ! After the working, attach all covers that were detached.

1-1. Rotary hook

- 1 Attach nozzle 2 (accessory) to the tip of the oiler 1.
- 2 Insert the nozzle into the lubrication hole 3 in the rotary hook and lubricate.

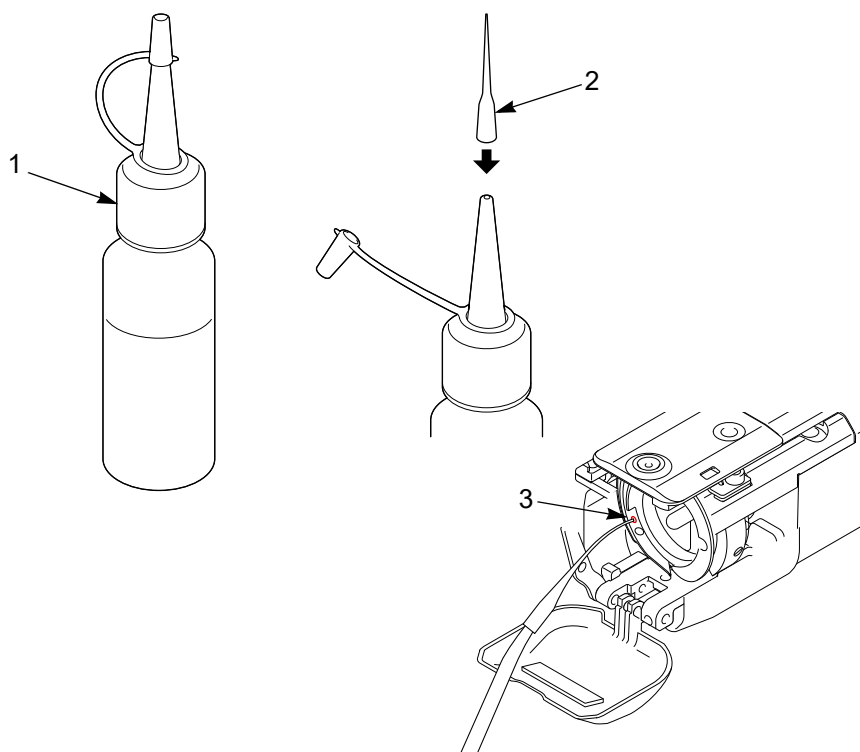

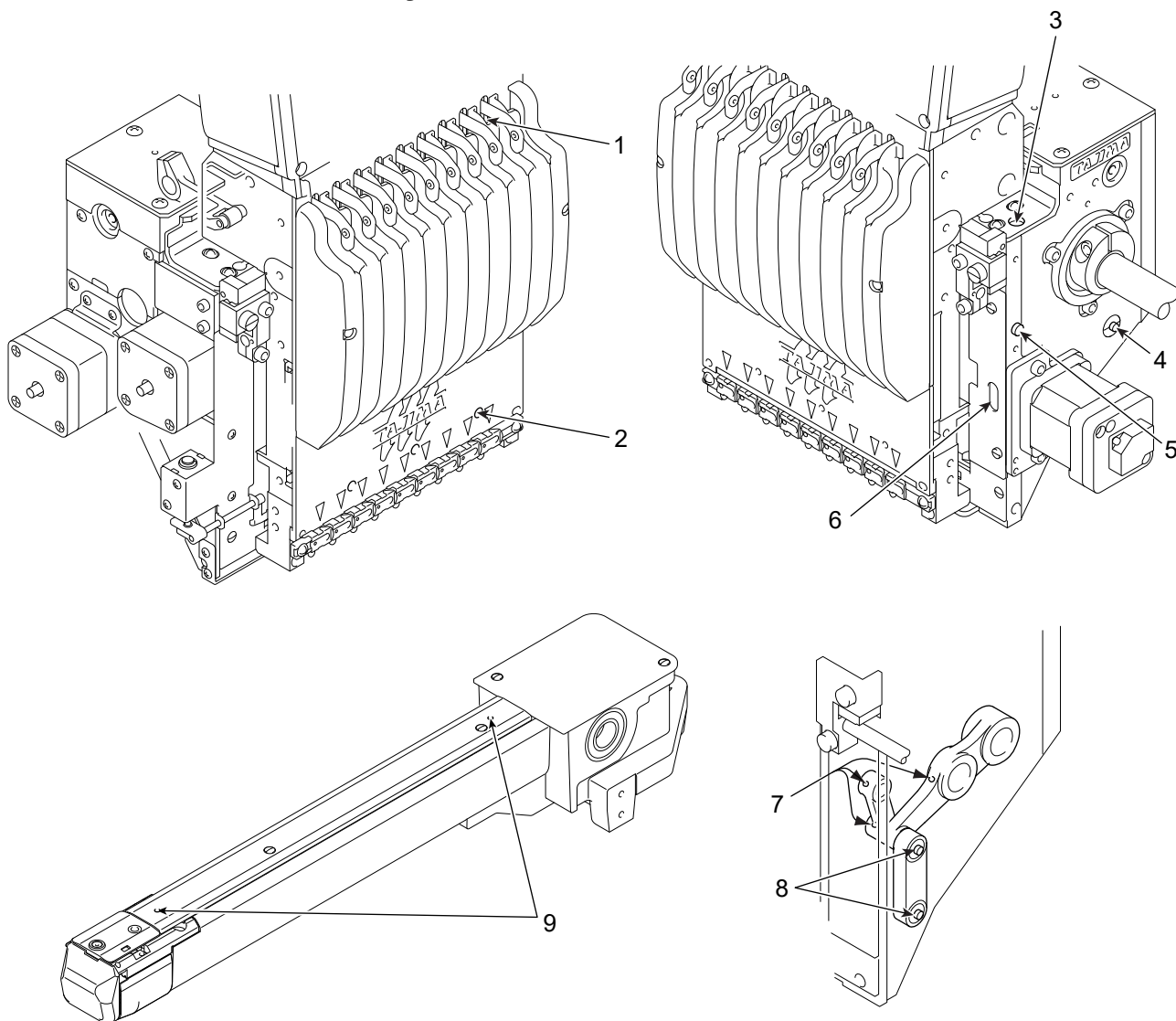

1-2. Inside of arm and cylinder bed



Lubricating spot
1: Needle bar
2: Needle bar
3: Needle bar drive shaft (needle bar side)
4: Wick of stepped pin
5: Wick of arm side (presser foot drive shaft)
6: Needle bar lever, connecting rod
7: Needle bar lever, connecting rod
8: Connecting rod
9: Rotary hook shaft

2. Idling, jump

CAUTION

-  When operating the machine, check if there is no person around the moving section and all covers are attached to prevent accident resulting in injury or death.
-  Keep on idling until antirust applied on the rotary hook is completely removed. If antirust remains, it could cause thread breakage.

- 1 Set “P3-26. Upper thread breakage detection” and “P3-27. Under thread breakage detection” to “Any: 0” in parameter setting.
- 2 Execute the data set of the design data containing jump codes.
- 3 Start the machine to perform idling. In the beginning, start idling from about 250 rpm and increase the number of revolutions to 650 rpm while checking the operating condition of the machine. Devote 20 to 30 minutes to operate the machine.
- 4 Check if no misjumping occurs for any needle, using design data that includes jump codes.
- 5 When misjumping occurs, it is necessary to adjust the position of the upper dead point stopper.
- 6 After the working, check if no heat occurs from the side part of the arm, the needle bar drive shaft, etc.

3. Threading

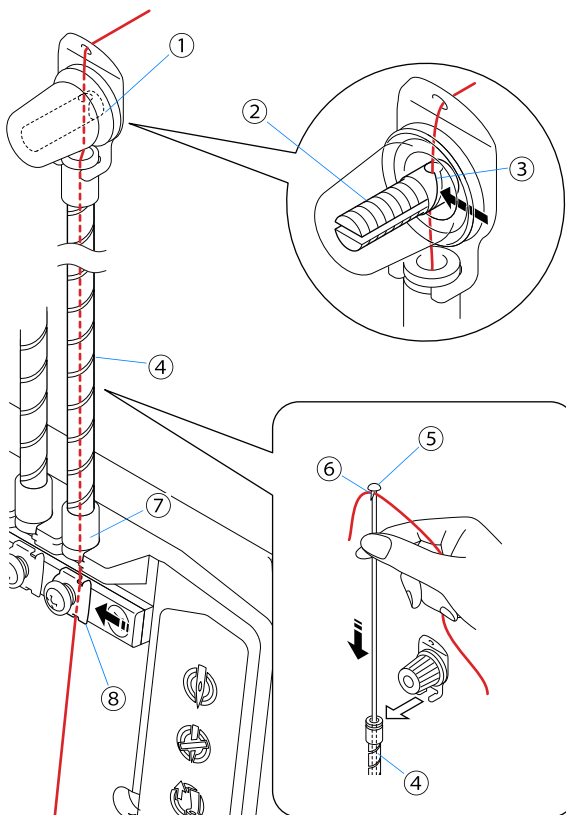

1 Thread tension regulator No. 1 (1)

Put the thread into the groove (3) of the tension stud (2).

 If you do not pass the thread through the groove, the upper thread may come off the thread tension regulator (1) during embroidery.

2 Spiral tube (4)

Hook the thread on the hooking part (6) of the threader (5) (accessory) and insert the thread into the spiral tube (4).

Pull out the threader (5) from the tube opening (7) fixed to the tension base and pass the thread through the spiral tube (4).

3 Thread presser (8)

Lift the thread presser (8) with your fingers and pass the thread through the thread presser (8).

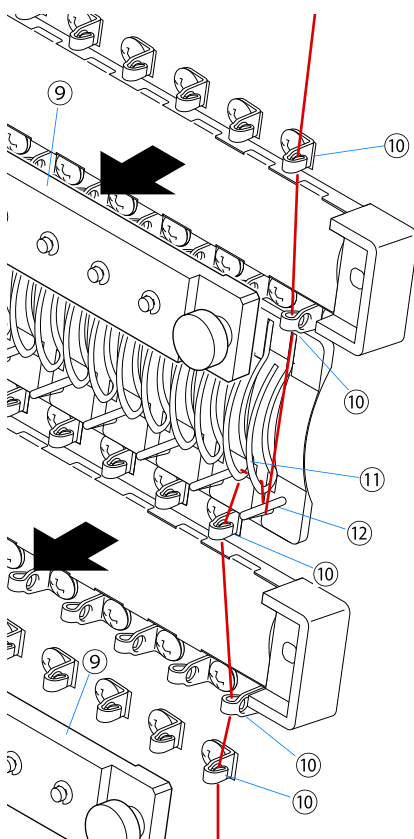

4 Disk bars (9) (upper side and lower side)

Remove the disk bars (9) (upper side and lower side).

 The disc bar (9) is fitted with a magnet. Hold the knob and remove it.

5 Take-up lever guide (11)

Pass the thread through the two thread guides (10), and to the thread guide (11) from the hook guide (12).

6 Lower side disk bar (9)

Pass the thread through the three thread guides (10).

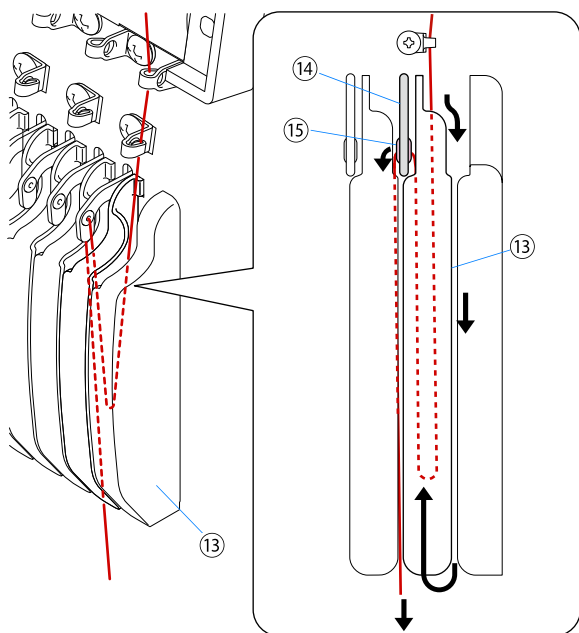

7 Middle thread guide ⑬

After hooking the thread to the middle thread guide ⑬ in the needle bar case, pass the thread into the hole ⑮ of the take-up lever ⑭ from the right-hand side.

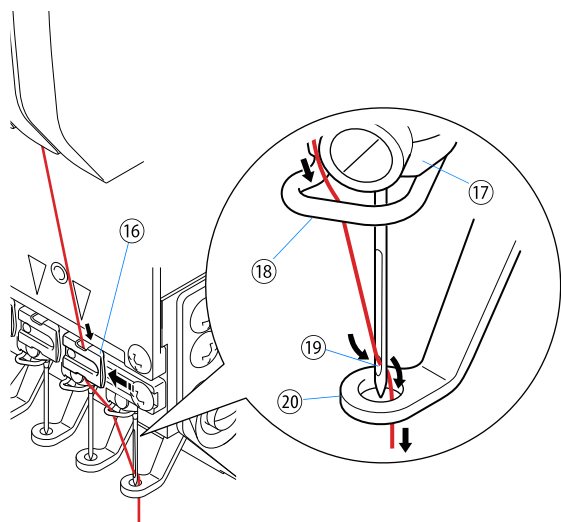

8 Upper thread lock ⑯

Lift the upper thread lock ⑯ with your fingers and pass the thread through the upper thread lock ⑯.

9 Surrounding needle

After passing the thread through the thread holder ⑱ of the needle clamp ⑰, pass the thread from the front of the needle eye ⑲ to the rear.

Furthermore, pass the thread from the needle eye ⑲ to the hole of the presser foot ⑳.

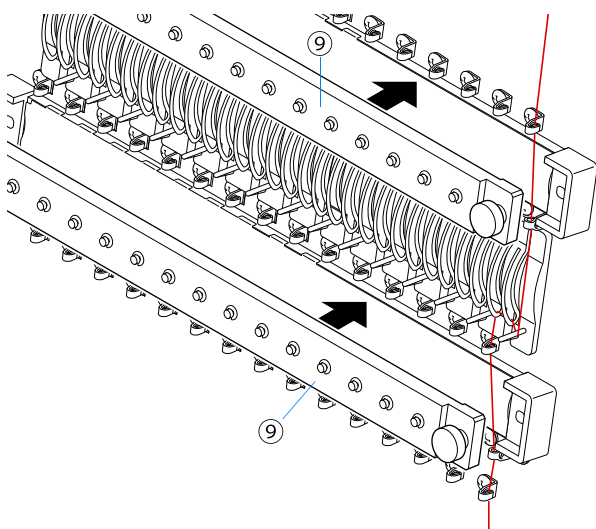

10 Disk bar ⑨

After passing all threads, finally set the disk bars ⑨ (on the upper side and lower side).

 There is no problem even if the disk bars ⑨ are interchanged between upper and lower sides, or right and left.

4. Test sewing

Stretch fabric on the frame, set under thread bobbin and check each movement such as color change, manual ATH, etc. Then, start test sewing.

CAUTION

-  In order to keep the machine in good condition for a long time, operate the machine at about 70% of the maximum speed for about two weeks as “operation for total fitting” after installation. By performing the operation for total fitting, the life of the machine will become longer, which will be useful to avoid unexpected troubles.

1st edition July 2020

3rd edition October 2023

■ **Manufactured by:**
TISM Co.,Ltd.

Address : NO.1800, Ushiyama-cho, Kasugai, Aichi-pref., 486-0901, Japan
TEL : 81-568-33-1161 Fax : 81-568-33-1191

■ **Distributed by:**
Tajima Industries Ltd.

Address : NO.1800, Ushiyama-cho, Kasugai, Aichi-pref., 486-0901, Japan
TEL : 81-568-37-1130 Fax : 81-568-37-1230

●**Copy, reprint, or reform of a part or whole of this manual without permission is prohibited.**