



ENGINEER'S MANUAL

Machine Setup Instructions

Manual for machine setup instructions

TMBR2-SC
TMBP2-SC
TMBP2-XC

Foreword

This is a setup manual for TMBR2-SC / TMBP2-SC / TMBP2-XC.

It is a document for engineers performing the after-sales service of machines.

Be sure to understand the necessary parts, procedure, and precautions through this manual before setting up the machine.

Safety precautions

To prevent any harm or damage to those who use this product or other people, we describe items that must be surely followed as below.



Indicates that there is a lot of danger of death or serious injuries [*1] if handled by mistake.



Indicates that there is a likelihood of death or serious injuries [*1] if handled by mistake.





Indicates a potentially hazardous situation which may result in minor or moderate injury [*2] or property damage if handled by mistake.

*1: A condition caused by electric shock, injury, fracture of a bone, etc., that leads to aftereffects, or an injury that necessitates hospitalization or visits to a hospital over a long period.

*2: An injury that does not necessitate hospitalization or visit to a hospital over a long period.

: Prohibited items

: Items that may cause electric shock if not observed

: Items that must be followed carefully to ensure safe operation



MUST DO LIST AT MACHINE INSTALLATION

MODEL:	M/NO.:
	DATE / / / PIC:

Check the following items in order after “Chapter 5 Level adjustment”.

Chapter 6 Adjustments	Remarks	✓
1. Needle locating position	Check and adjust the needle locating position. <ul style="list-style-type: none"> The 1st needle on all heads The last needle on all heads Equalize it at the 1st needle and the last needle.	✓
2. Lower dead point	Check and adjust the lower dead point.	✓
3. Upper dead point	Check and adjust the upper dead point.	✓
4. Bevel gear	Check and adjust bevel gears gap in front/rear, left/right direction.	✓
5. Needle and rotary hook	Check and adjust the needle and the rotary hook timing and the gap.	✓

Chapter 7 Idling and test sewing	Remarks	✓
1. Lubrication	Lubricate to the rotary hook and the inside of the arm.	✓
2. Idling, jump	Run the machine at least 20 minutes without threads for all needles to remove anti-rust liquid from the rotary hook.	✓
	Check if the reciprocator catches the needle bar stud at inching.	✓
	Check if the jump device operates properly.	✓
8. Threader	Pass thread correctly.	✓
9. Test sewing	Check if the thread breakage or the needle breakage occurs.	✓

Table of Contents >>

Chapter 1 Transportation, Storage, Delivery

1. Transportation, Storage 7
2. Installation environment 7
3. How to carry 9

Chapter 2 Installation

1. Stand 10
 - 1-1. When the stand is not attached 10
 - 1-2. When the stand is attached 11

Chapter 3 Detaching, attaching

1. Detaching 14
 - 1-1. Stopper 14
2. Attaching 15
 - 2-1. Thread course (TMBR2-SC, TMBP2-SC) 15
 - 2-2. Thread course (TMBP2-XC) 15
 - 2-3. Beam sensor (limited model) 16

Chapter 4 Connection of power cord

1. Important safety instructions 18
2. Power cord 20
3. Parameter setting 21

Chapter 5 Level adjustment

1. Level adjustment 22
 - 1-1. When the stand is not attached 22
 - 1-2. When the stand is attached 23

Chapter 6 Adjustments

1. Needle locating position 24
2. Lower dead point 26
3. Upper dead point 33
4. Bevel gear 35
5. Needle and rotary hook 36

Chapter 7 Idling and test sewing

1. Lubrication 37
 - 1-1. Rotary hook 37
 - 1-2. Inside of arm and cylinder bed 38
2. Idling, jump 40
8. Threader 41
9. Test sewing 43

User's manual / Parts list

User's manual / Parts list are stored as the PDF file in the accessory DVD.

Please read the contents thoroughly and then use the machine or the optional device.

To see the PDF file, "Adobe Acrobat Reader" is necessary.

User's manual, parts list of the optional devices you have not purchased are also included in this DVD.

Please note beforehand.

[How to open the DVD]

1. Insert the DVD into the personal computer.



Since the following pop-up window will be displayed automatically, select "Open folder to view files" (indicated by the arrow).



2. Double-click left "title page".

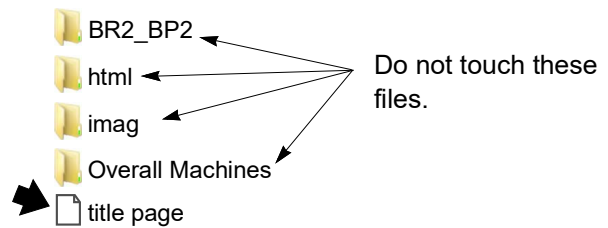

3. Select displaying language.

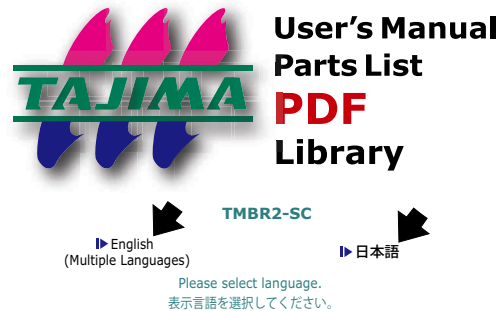

4. Select "User's Manual" or "Parts List", and then select the title you desire.

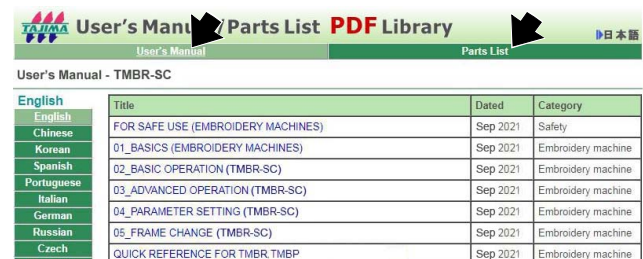

The figure above is an example selecting "English (Multiple Languages)" in the above 3.

Chapter 1 Transportation, Storage, Delivery

1. Transportation, Storage

⚠ CAUTION

- ❗ To prevent personal injury, lift or transport the machine in a safe manner to prevent it from tipping over or falling, based on the weight of the machine.
- ❗ To prevent machine failure and premature deterioration, store the machine in the following environment.
Humidity: 30 to 95%RH (relative humidity) without condensation
Ambient temperature: -10 to 60°C (during storage)

2. Installation environment

⚠ CAUTION

- ❗ Install the machine on a sturdy floor.

The floor structure must be strong enough to bear the machine weight (indicated on the spec. plate). If the floor is supported by steel frames, place the machine stand on the steel beams as long as possible.

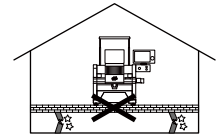

- ❗ Install the machine on a stand or desk with a height of 30 cm or more, which has sufficient load bearing capacity for the weight of the machine.

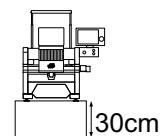

- ❗ Control the operation noise in the environment.

This machine is designed to reduce noise during operation. To improve the sound insulation performance in the factory still more, use the interior finish materials which show high sound insulating performance for the walls, ceiling, and floor of the factory.

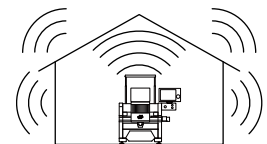

- ⊘ Avoid direct sunlight.

If the machine is exposed to direct sunlight over an extended period of time, the machine body may be discolored or deformed. Put curtains or shades to the sight to prevent the machine from direct sunlight.

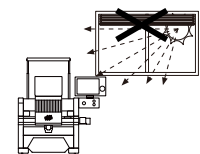

- ❗ Provide enough space for maintenance.

Taking account of operability when maintaining and inspecting the machine, provide working space of 75 cm or more to right and left, and 75 cm or more to rear directions for the machine against obstacles such as walls.

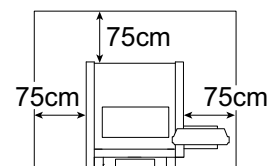

CAUTION

 Avoid dust and moisture.

Since dust and moisture lead to dirt and rust on the machine, use the machine in an environment of facility of air conditioner, and clean the working place periodically. Use caution not to expose the machine to direct wind from the air conditioner so that embroidery threads do not become disheveled.

Degree of pollution: 2 or less

Humidity: 30 to 95%RH (relative humidity) without condensation

Ambient temperature: 5 to 40°C (during operation)

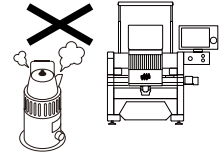

 Pay attention to interference of radio wave.

Although the machine is designed not to apply radio wave to other equipment, there could be cases where it causes radio wave interference depending on the operating environment and type of equipment to be used. If such problems arise, install the equipment as apart from the machine as possible.

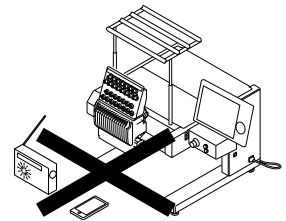

 Pay attention to power supply style.

When supplying the power, meet the following requirement.

- Excess voltage category: III

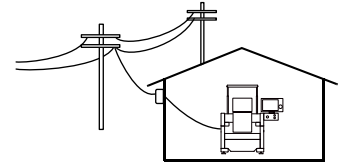

 Do not use the machine in such a place where a strong electric field or magnetic field occurs by such a high-frequency welder of large output power.

3. How to carry

■ TMBR2-SC, TMBP2-SC

⚠ WARNING

❗ Carry the machine by four or more people. Dropping could cause injury or breakdown.

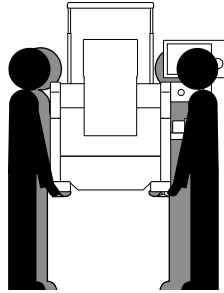

❗ When carrying the machine, hold the correct spots. Dropping could cause injury or breakdown.

When the stand is attached (→ See page 11)

When the stand is not attached

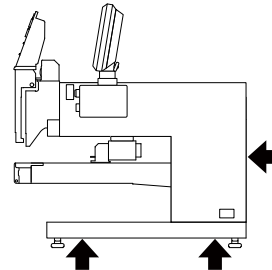
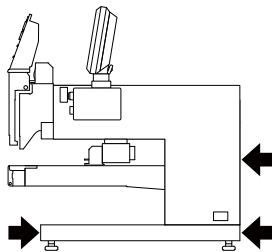

■ TMBP2-XC

⚠ WARNING

❗ Carry the machine by four or more people. Dropping could cause injury or breakdown.

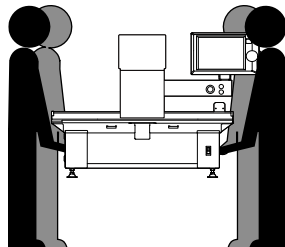

❗ When carrying the machine, hold the correct spots. Dropping could cause injury or breakdown.

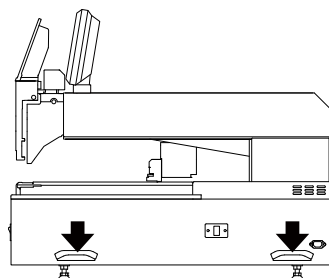

Chapter 2 Installation

1. Stand

1-1. When the stand is not attached

■ TMBR2-SC, TMBP2-SC

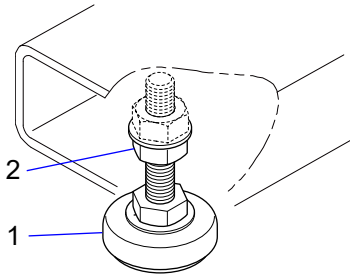

Make adjustments to adjuster 1 so that the load of the machine is applied equally, and fix nut 2.

■ TMBP2-XC

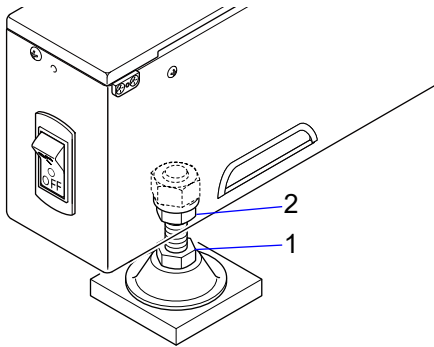

Make adjustments to adjuster 1 so that the load of the machine is applied equally, and fix nut 2.

1-2. When the stand is attached

■ TMBR2-SC, TMBP2-SC

1 Assembling stand

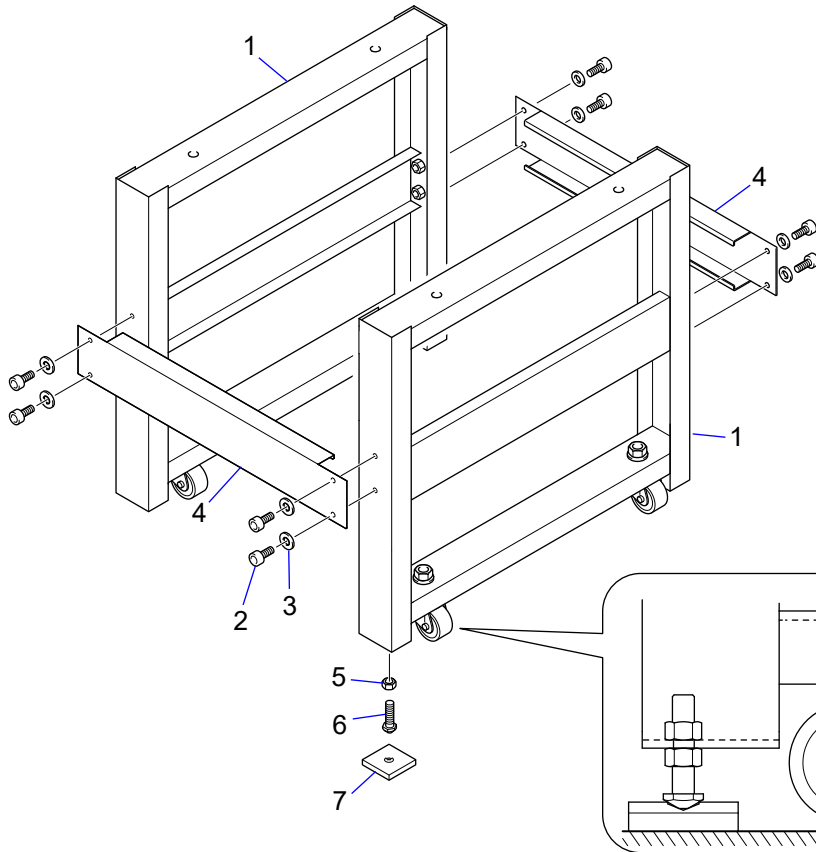

- 1 Stand
- 2 Hexagon socket head cap screw M8 x 15
- 3 Plain washer M8 x 18
- 4 Stand joint
- 5 Hexagon nut M12 (Type 1)
- 6 Leveling bolt M12 x 50
- 7 Vibration-preventive base

2 Place the machine on the stand and fix it by using two screws at the rear side only.

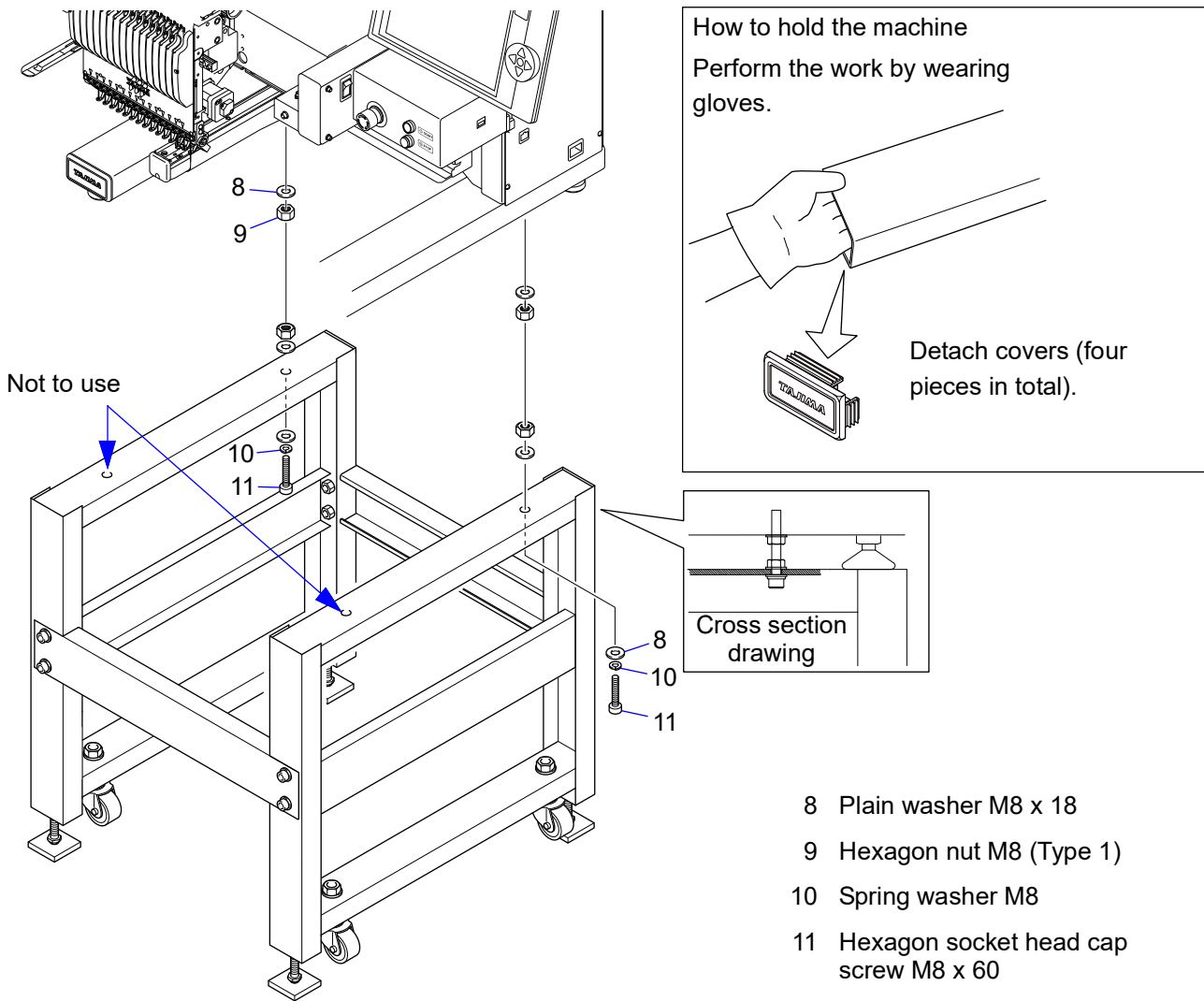

TMBP2-XC

1 Assembling stand

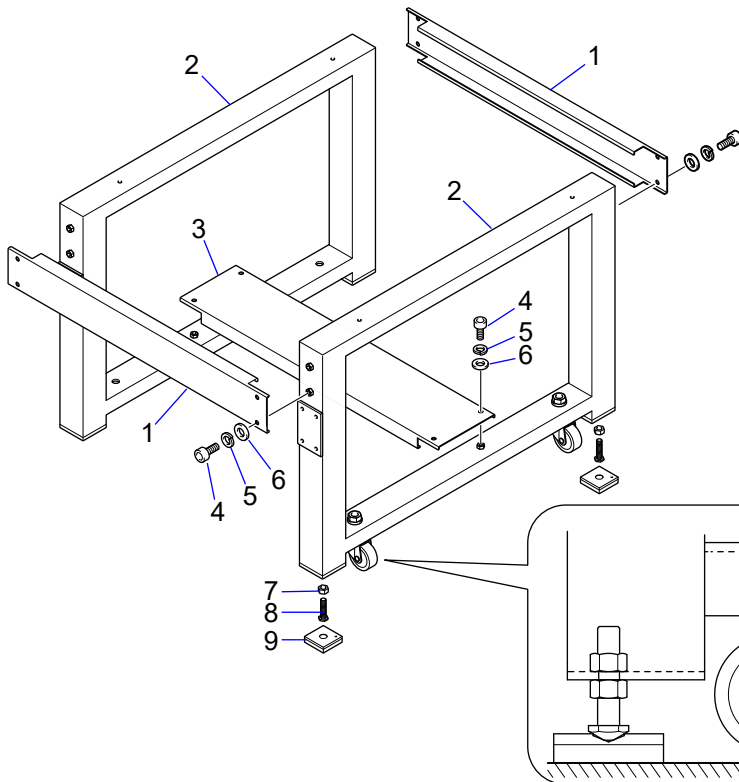

- 1 Joint stand base
- 2 Stand base
- 3 Joint stand base B
- 4 Hexagon socket head cap screw M8 x 15
- 5 Spring washer M8
- 6 Plain washer M8 x 18
- 7 Hexagon nut M12 (Type 1)
- 8 Leveling bolt M12 x 50
- 9 Vibration-preventive base

2 Place the machine on the stand and fix it by using four screws.

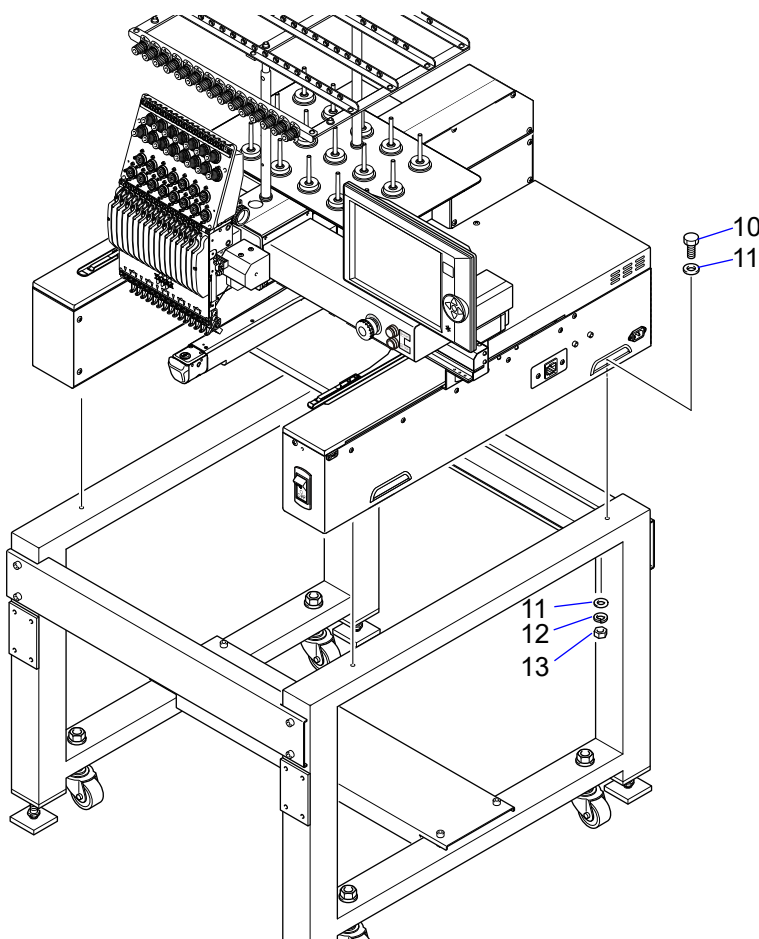

- 10 Hexagon bolt M8 x 25
- 11 Plain washer M8 x 18
- 12 Spring washer M8
- 13 Hexagon nut M8 (Type 1)

Chapter 3 Detaching, attaching

1. Detaching

1-1. Stopper

- 1 Before using the machine, detach stopper 1.

Stoppers are attached to right and left sides of the needle bar case.

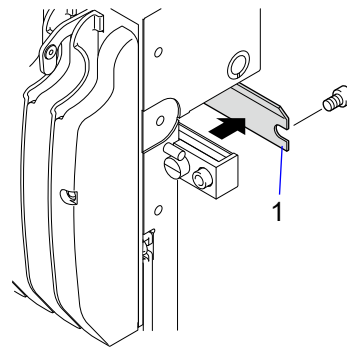
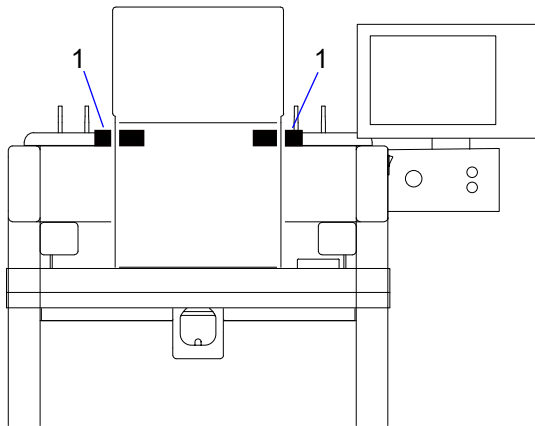

2. Attaching

2-1. Thread course (TMBR2-SC, TMBP2-SC)

- 1 Remove screws 1, pull up thread course 2, and relocate screws 1 to the upper holes.
- 2 Insert and fix the thread stand stud 5 through base 4 into hole 3 of the thread stand plate.
- 3 Insert thread stand blade 7 into thread stand stud 5 and set thread stand ring 6.

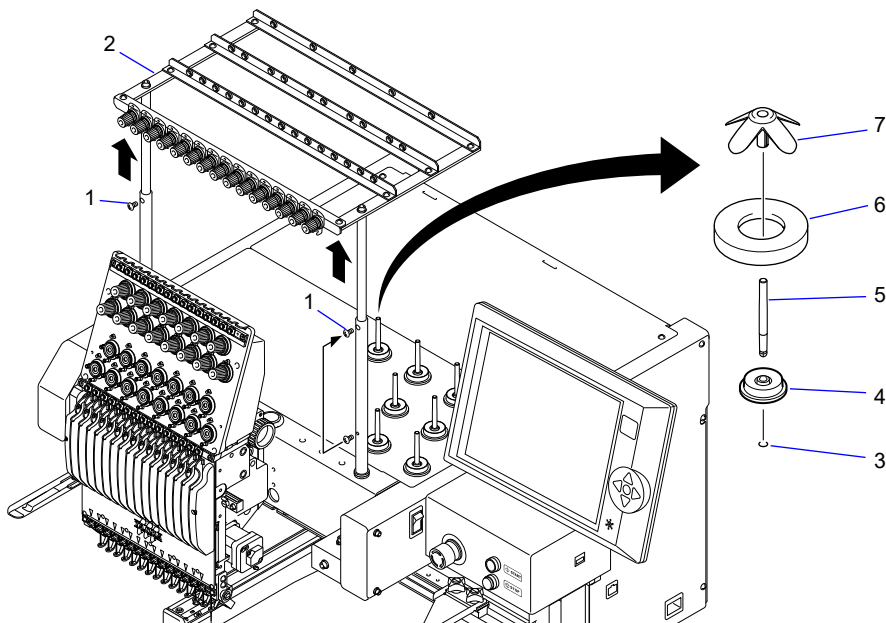

2-2. Thread course (TMBP2-XC)

- 1 Remove screws 1, pull up thread course 2, and relocate screws 1 to the upper holes.
- 2 Insert and fix the thread stand stud 5 through base 4 into hole 3 of the thread stand plate.
- 3 Insert thread stand blade 7 into thread stand stud 5 and set thread stand ring 6.

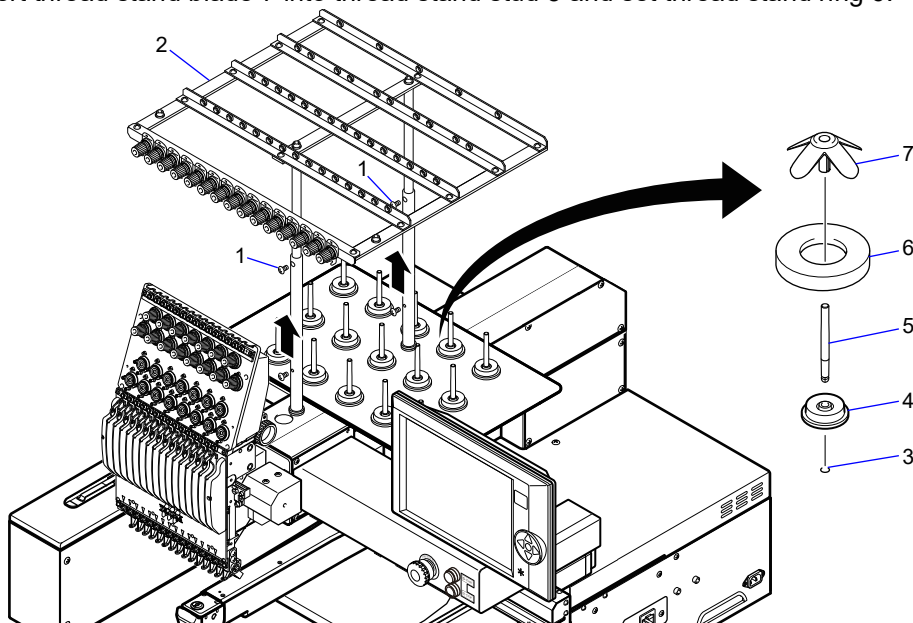

2-3. Beam sensor (limited model)

■ Without optional device

You have no attaching work

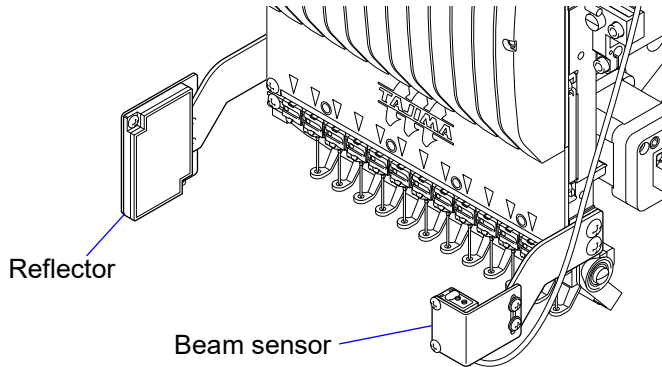

■ The machine equipped with sequin device IV

The beam sensor is attached downward before shipping. Fix it in the proper position by the following procedure.

- 1 Loosen the screw 2 (M4X8), level the sensor arm 1 one by one, and fix it with the screw 2. The screws are included in the accessories.

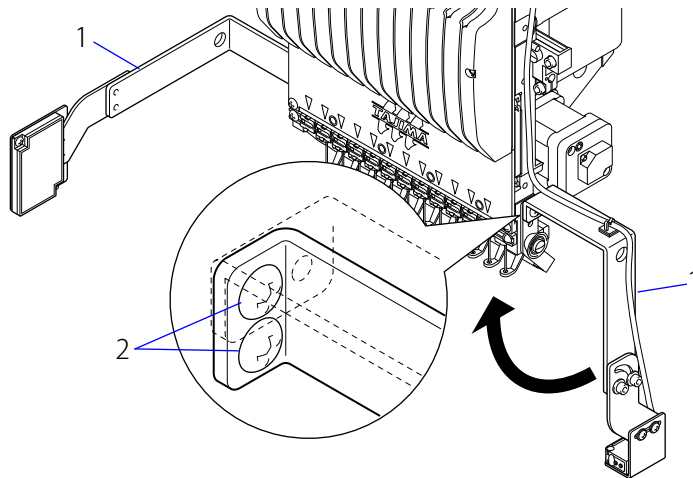

- 2 Check the following points at the first and last needles and adjust the attaching position of the upper thread holder, as necessary.

Lower the presser foot and check that the presser foot does not come in contact with the upper thread holder.

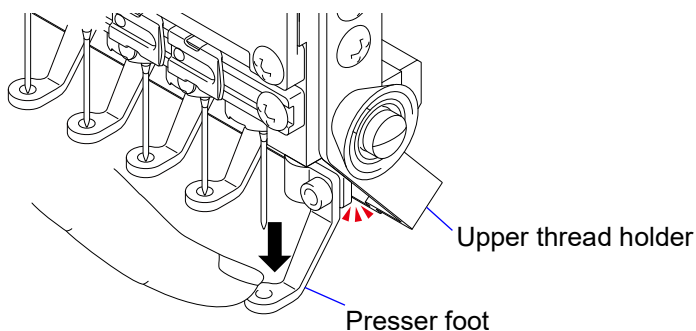

Check that the upper thread holding hook is actuated normally.

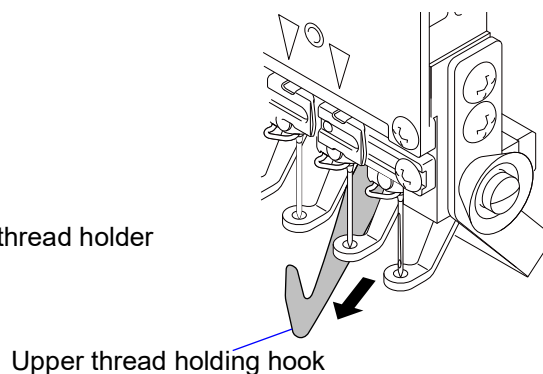

■ The machine equipped with seed beads device

The beam sensor is attached upward before shipping. Fix it in the proper position by the following procedure.

- 1 Remove screws 2 (M4*8) on the left and right sensor arms 1.

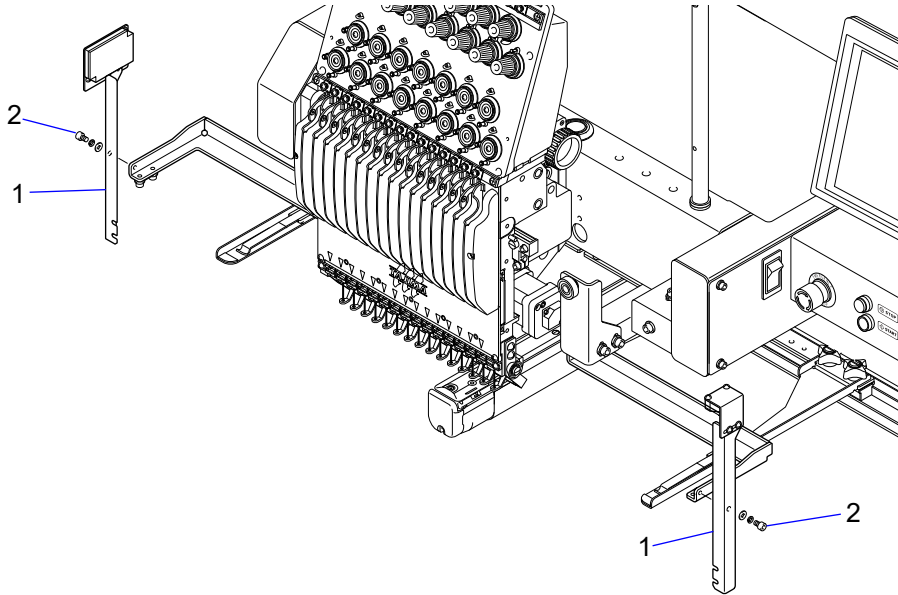

- 2 Level the left and right sensor arms 1 and fix them with screws 2 (M4*8).

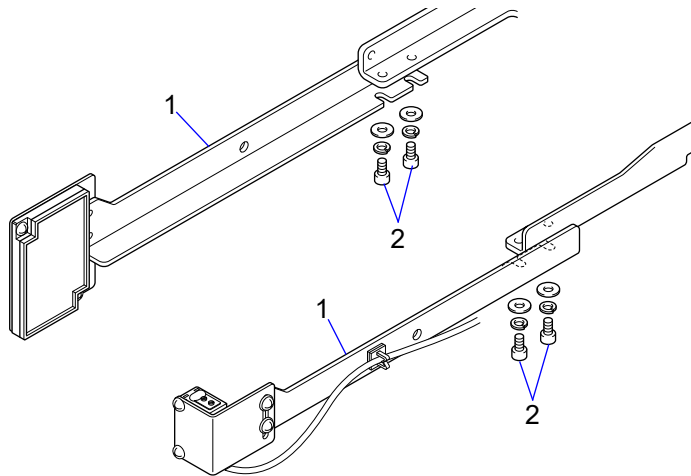

Chapter 4 Connection of power cord

1. Important safety instructions

⚠ WARNING

- ⊘ Do not use this product at voltages other than the rated voltage of the machine. Failure to do so may result in fire, electric shock, or malfunction.
- ⚠ When supplying the power, conform to excess voltage category "III".
- ⚠ Connect the machine to the power supply line that is not connected to machines subject to large load fluctuation such as elevators and presses so that the machine can operate in stable conditions.
- ⚠ Check if power voltage is enough for operating the machine by using a multimeter.
Voltage: Within $\pm 10\%$ of the rated voltage
- ⚠ The power supply cable must be laid out of the operator's moving area so that the operator does not step on the cable.
- ⚠ Insert the power cable plug fully. If a metallic part etc. touches a blade in the plug, it may cause fire and/or electric shock.
- ⚠ Since there is the danger of electric shock due to leak current, be sure to connect the grounding wire. In addition, degree of grounding should be type D or higher (grounding resistance 100 ohms or less).

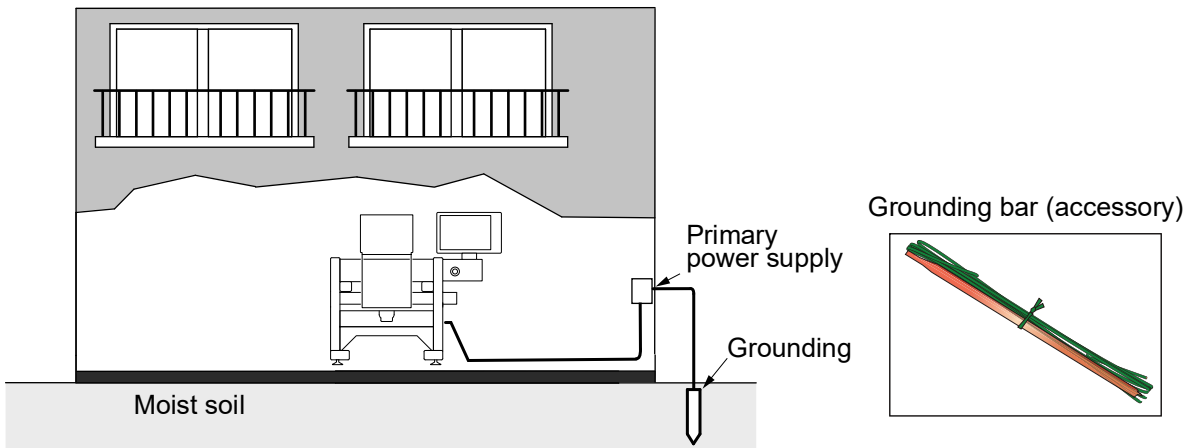

⚠ CAUTION

- ⚠ In addition to full-time leak current, leak current generated by harmonics and surge flows in the power cable of the machine. For this reason, if the selection and installation of the earth leakage circuit breaker and leak current relay used for the factory are not correct, the malfunctioning of the machine may occur. Regarding connection of power cord, observe the following items.
- ⚠ Use a breaker of electric current leakage and leak current relay for which measures are taken against harmonics and surge. If such a breaker and a relay are not available, select conventional breaker and relay with sufficient leak current capacity to absorb leak current caused by harmonics and surge. (In this case, constant leak current must be controlled satisfactorily.)





 **CAUTION**

- ❗ Regarding capacity of electric current leakage for breaker of electric current leakage and leak current relay per machine, please consult your local TAJIMA distributor.
- ❗ For actual product names of breaker of electric current leakage and leak current relay for which measures are taken against harmonics and surge, please consult your local TAJIMA distributor or electric engineers.
- ❗ To prevent the machine from property damages, one embroidery machine should be connected to one no fuse breaker. Property damages include a drop of output of the main shaft motor, etc., stop position error and color change error caused by the stop position error, design displacement, etc.

2. Power cord

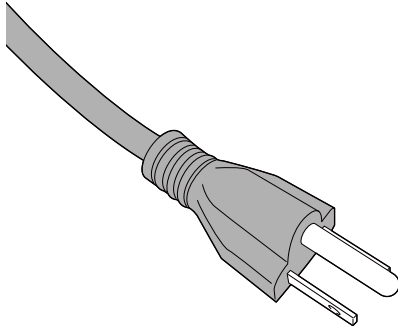
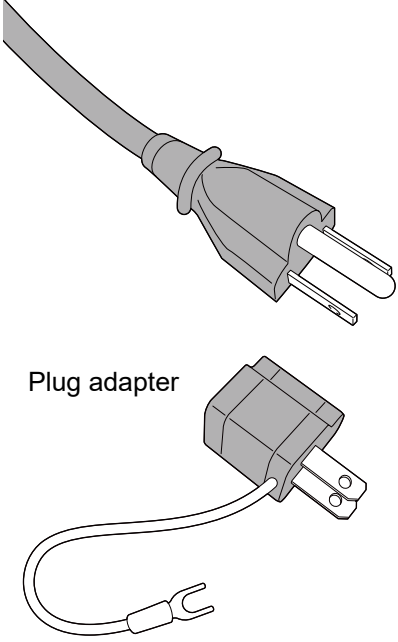
WARNING

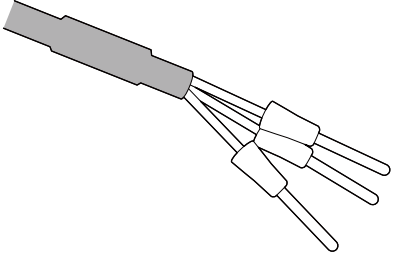
 Do not use a power cord other than the one provided. Failure to do so may result in fire, electric shock, or malfunction.

Exclusive item for UL/ CSA-spec.	For use in Japan	Other than the left
	 <p>Plug adapter</p>  <p>When using a plug adapter, ground the ground wire.</p>	  <p>Attach to a plug with a grounding terminal that matches the outlet to be connected, and ground the grounding wire.</p>

3. Parameter setting

A parameter list is attached to the back of the operation panel. Check setting values. At this moment, check also version of the software.

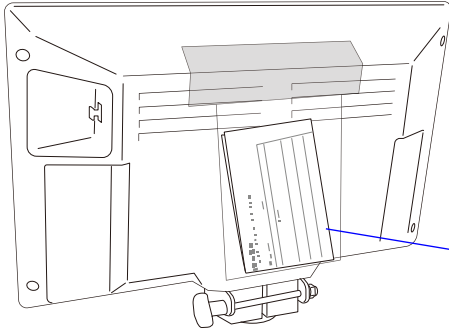

Regarding information about the latest version of software and how to obtain the software, consult the distributor.

"Parameter setting chart" at shipment from the factory is attached.

Chapter 5 Level adjustment

1. Level adjustment

1-1. When the stand is not attached

■ TMBR2-SC, TMBP2-SC

Check a degree of level of the machine against the floor using level gauge 1. If it is not horizontal, adjust the degree of level of the machine by using adjuster 2.

Spot where level gauge is to be used

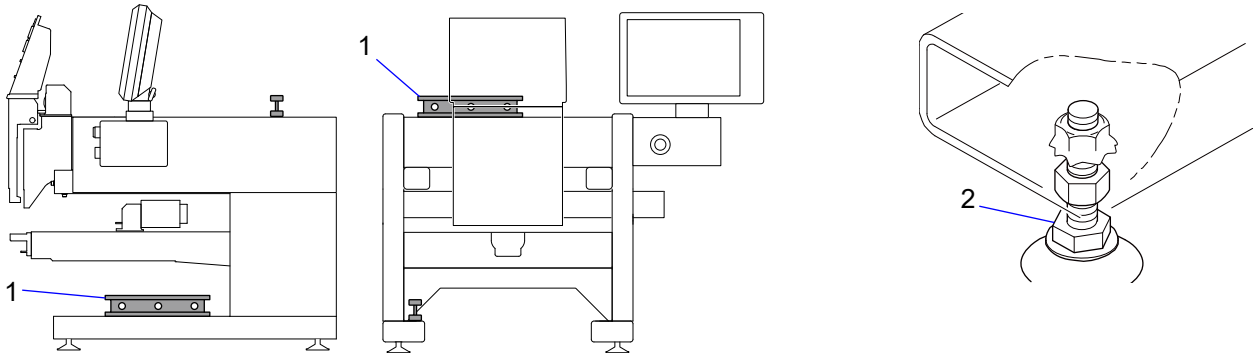

■ TMBP2-XC

Check a degree of level of the machine against the floor using level gauge 1. If it is not horizontal, adjust the degree of level of the machine by using adjuster 2.

Spot where level gauge is to be used

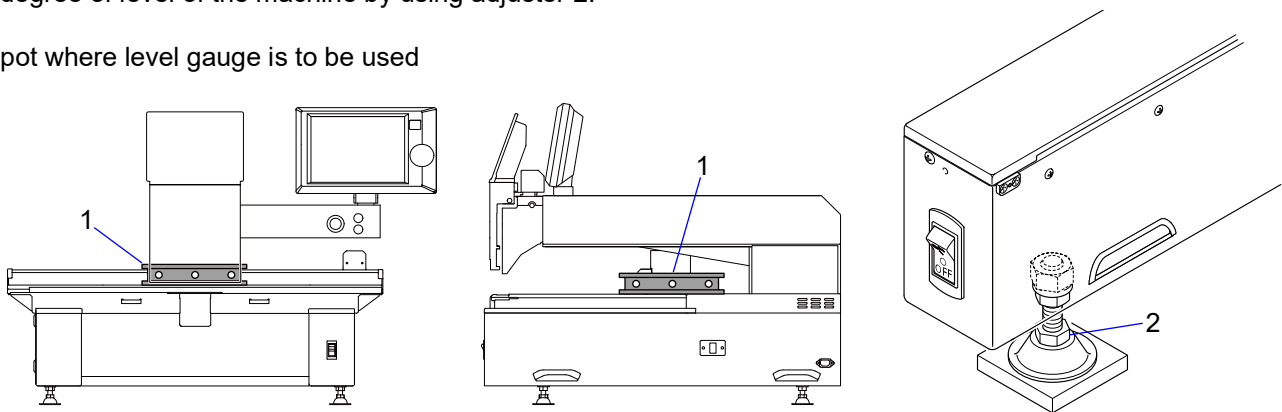

1-2. When the stand is attached

■ TMBR2-SC, TMBP2-SC, TMBP2-XC

Check a degree of level of the machine against the floor using level gauge. If it is not horizontal, adjust the degree of level of the machine by using leveling bolt 1.

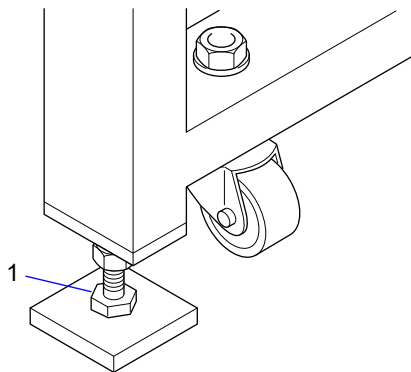



Chapter 6 Adjustments

1. Needle locating position

Perform this checking at the first needle and the last needle.

1 Pressing  for more than 2 seconds is to release the main shaft brake.

 will be flashing. Pressing  for a few seconds again activates the main shaft brake.

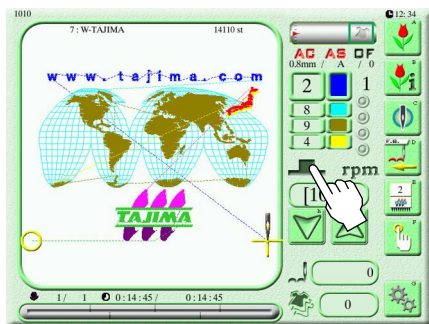

2 For TMBP2-SC, press  in the manual operation screen.

The presser foot will be lowered to the lower dead point.

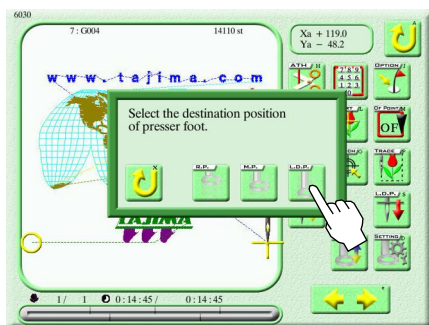

3 Turn the main shaft to set the main shaft angle to 178° (Needle bar lower dead point).

TMBR2-SC, TMBP2-SC

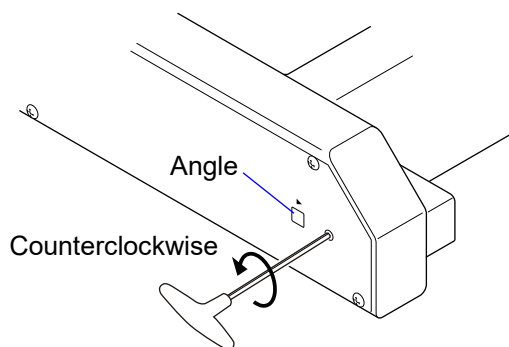

TMBP2-XC

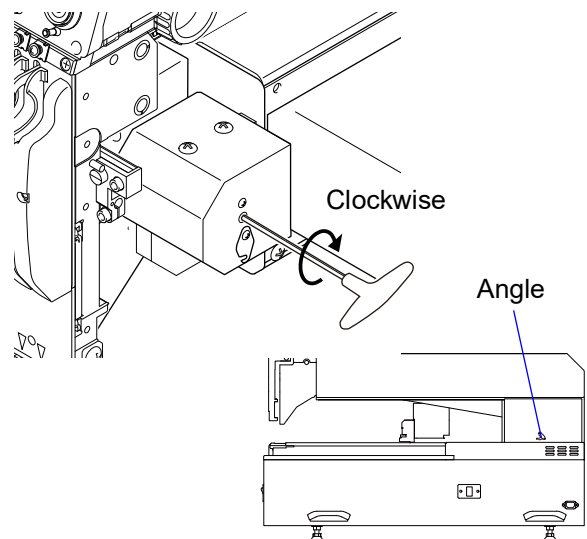

- 4 Lower the needle bar by hand.
- 5 Check if the needle is almost located at the center of needle hole.

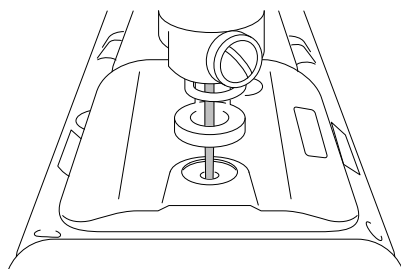

[Adjustment in the back and forth]

Loosen the screws 1 and move the needle plate bracket 2 back and forth to adjust the needle locating position.

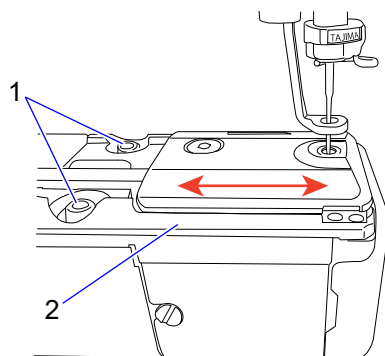

[Adjustment in the right and left]

Loosen the screws 1 and move the needle plate bracket 2 right and left to adjust the needle locating position.

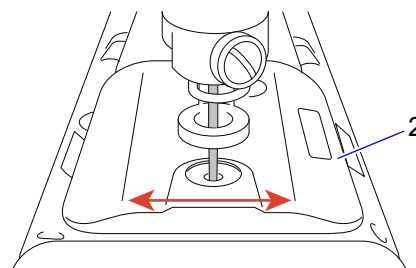

- 6 For TMBR2-SC, TMBP2-SC, turn the main shaft clockwise and set it to the 100° (fixed position).
For TMBP2-XC, turn the main shaft counterclockwise to set 100° (fixed position).
- 7 Perform Color Change to the last needle to check the needle locating position.
- 8 Set "9 Main Shaft Brake" to "YES" after confirming.

2. Lower dead point

■ TMBR2-SC

Perform this adjustment from the 1st needle to the last needle (All needle bars).

- 1 Lower the needle bar 1 by finger in the state of main shaft angle 178° (Needle bar lower dead point) and loosen screw 2.

How to lower the needle bar, refer to the detail page. (→ See page 24)

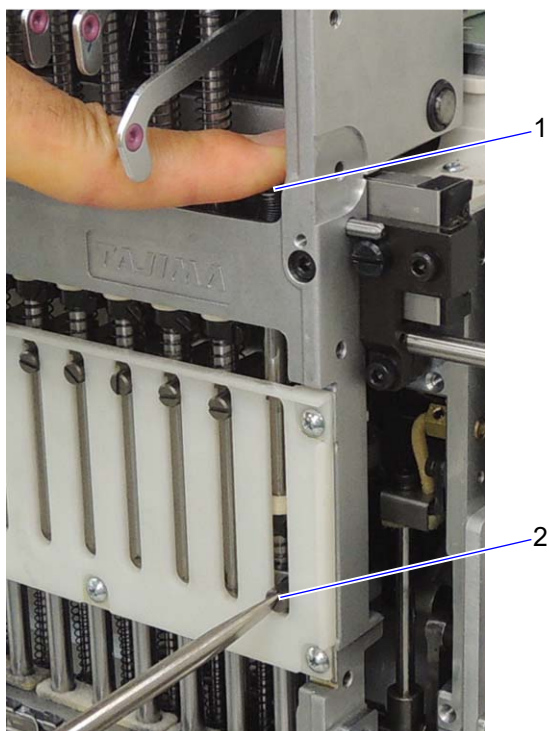

- 2 Attach the lower dead point gauge 3 so that the needle comes into groove 4.

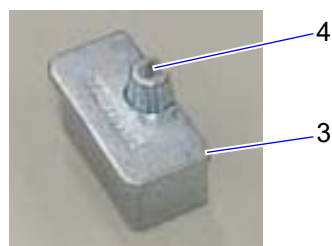
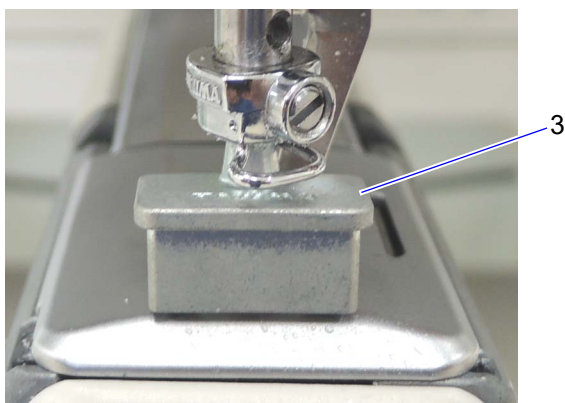

[When using the lower dead point adjustment support gauge]

- Put in the lower dead point adjustment support gauge 5 from underneath the needle bar connecting stud 6.

Lower dead point adjustment support gauge

(GAUGE :LOWER DEAD POINT :NEEDLE BAR CONNECTING STUD :B)

(Part no.: 7Z1401503000)

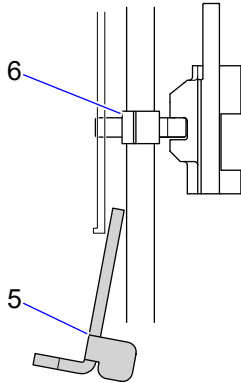

While pushing down the needle bar 1 by finger (with the needle bar 1 touched to the lower dead point gauge), raise the lower dead point adjustment support gauge 5 and tighten the screw 2 in the state that the needle clamp 7 faces as shown in the photo A.

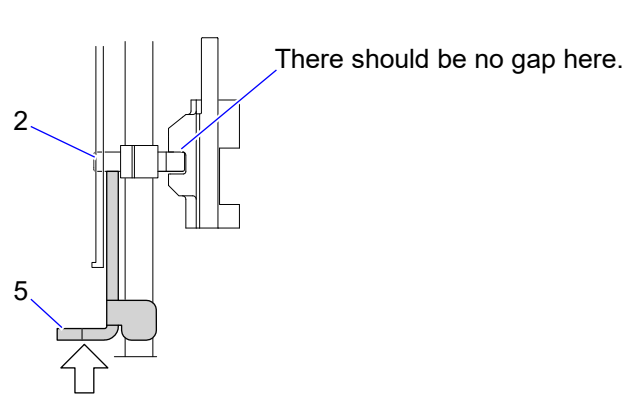
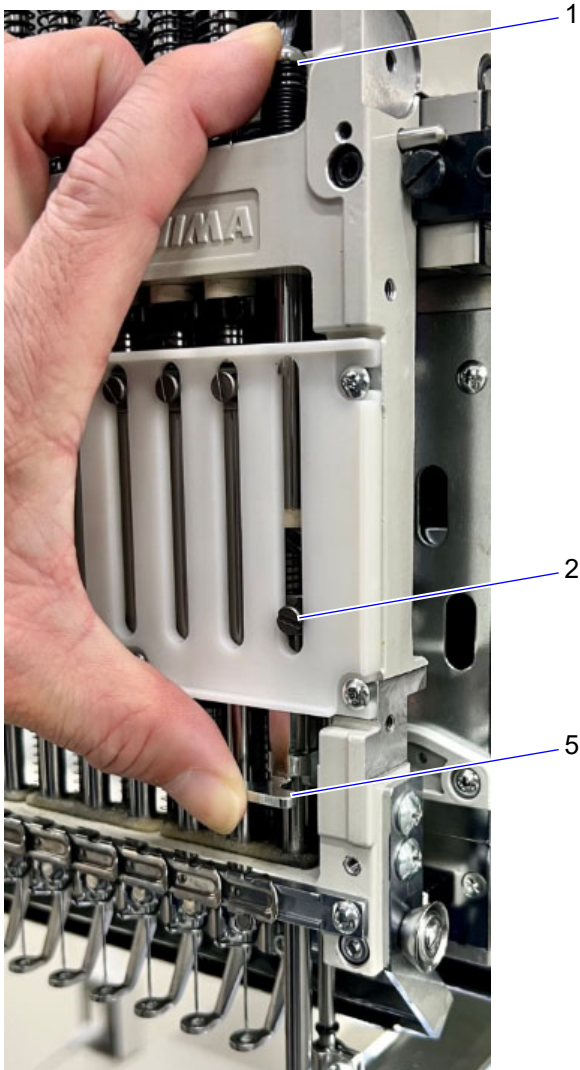
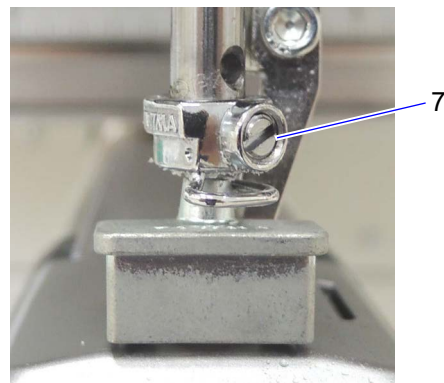

Photo A



After that, proceed to step 4 of page 28.

Chapter 6

2. Lower dead point

[When not using the lower dead point adjustment support gauge]

- 3 While pushing down the needle bar 1 by finger (with the needle bar 1 touched to the lower dead point gauge 3) and tighten the screw 2 in the state that the needle clamp 7 faces as shown in the photo A.

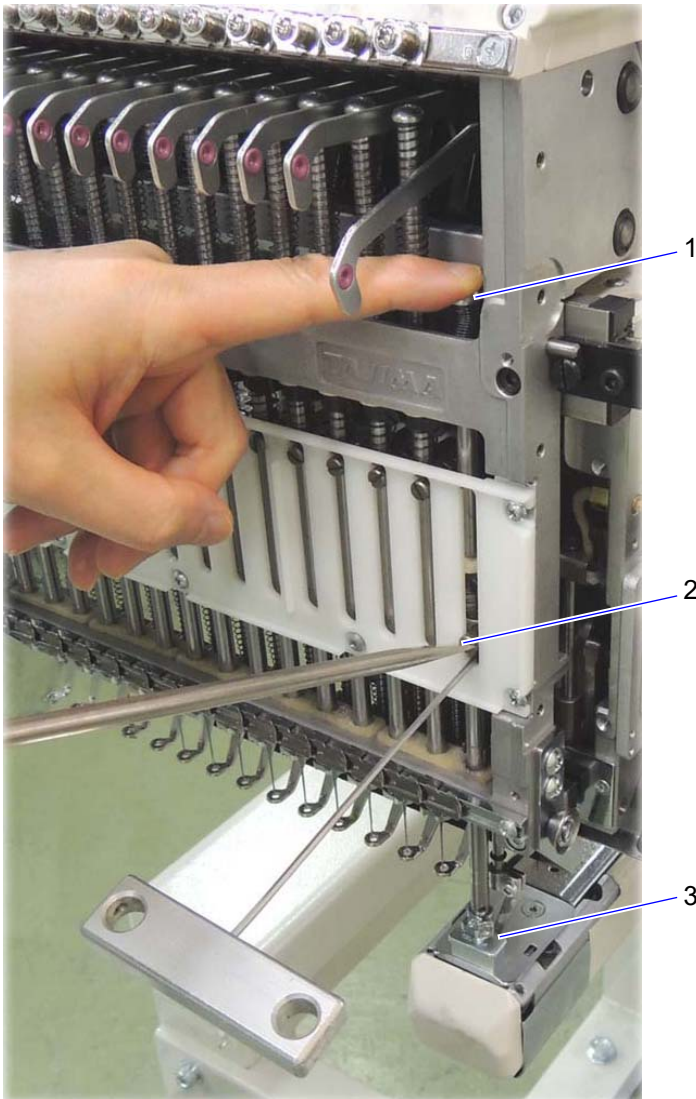

Tighten the screw 2 in the state that the needle bar connecting stud 6 is raised as shown in the figure below. In this example, the wrench 8 is used.

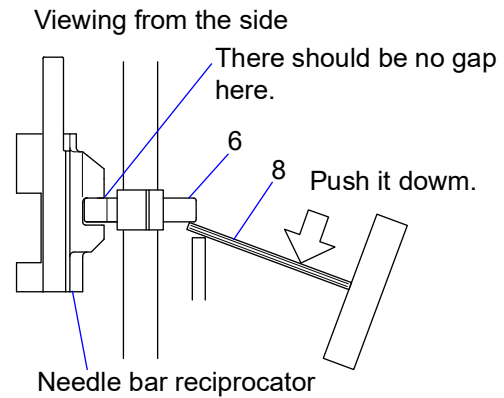
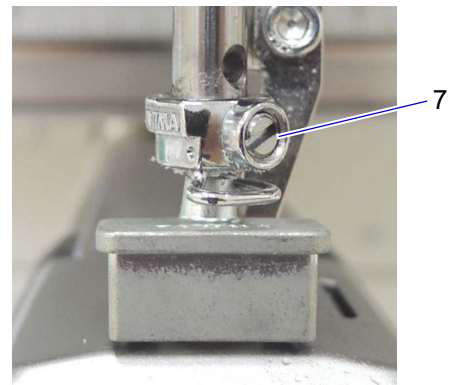
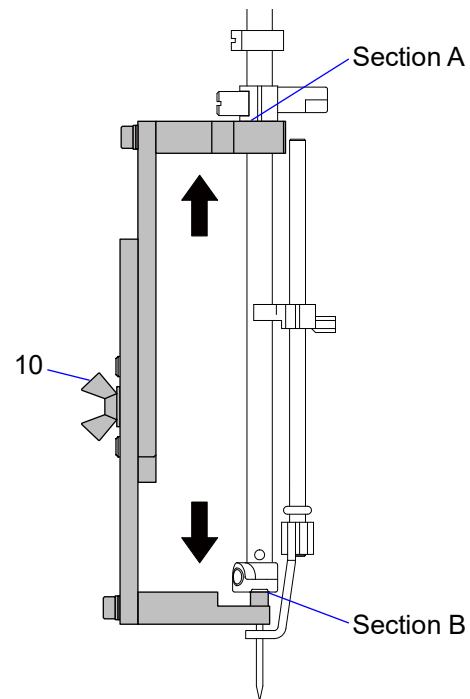
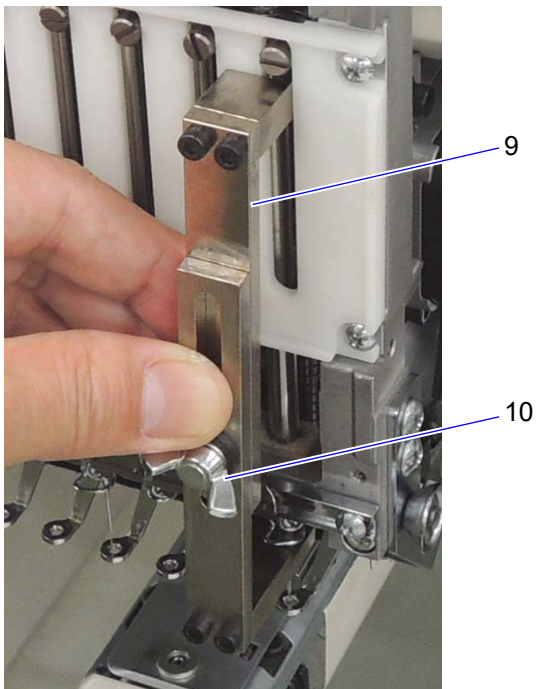

Photo A



- 4 Remove the lower dead point gauge.
- 5 Set the main shaft angle to 100° (Stop position).
- 6 Perform Color Change to the next needle bar.

- 7 Attach the connecting stud gauge 9 to the first needle. Loosen the wing screw 10 and then tighten the wing screw 10 with no gap between sections A and B.



Connecting stud gauge
(GAUGE :NEEDLE BAR CONNECTING STUD[A])
(Part no.: 7Z1481101A22)

- 8 Attach the connecting stud gauge 9 to the 2nd needle. Loosen the screw 11, and tighten the screw 11 with no gap between sections A and B. Perform working to the last needle.

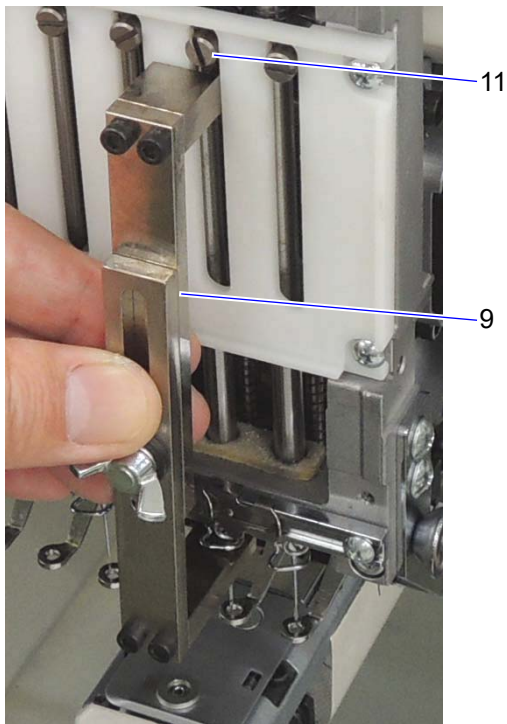

■ TMBP2-SC, TMBP2-XC

Perform this adjustment from the 1st needle to the last needle (All needle bars).

- 1 Lower the needle bar by finger in the state of main shaft angle 178° (Needle bar lower dead point) and loosen screw 1.



- 2 Attach the lower dead point gauge 2 so that the needle comes into groove 3.

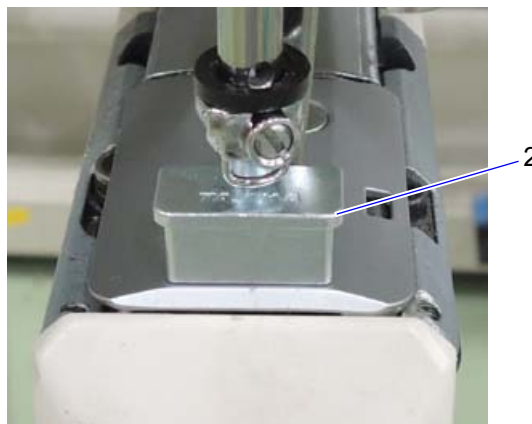
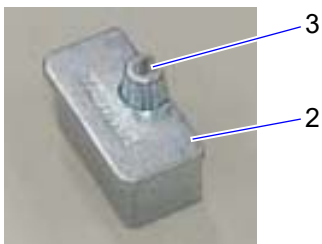

- 3 Push down needle bar 4 to touch to lower dead point gauge 2. Tighten the screw 1 in the state that needle clamp 5 faces as shown in the photo A.

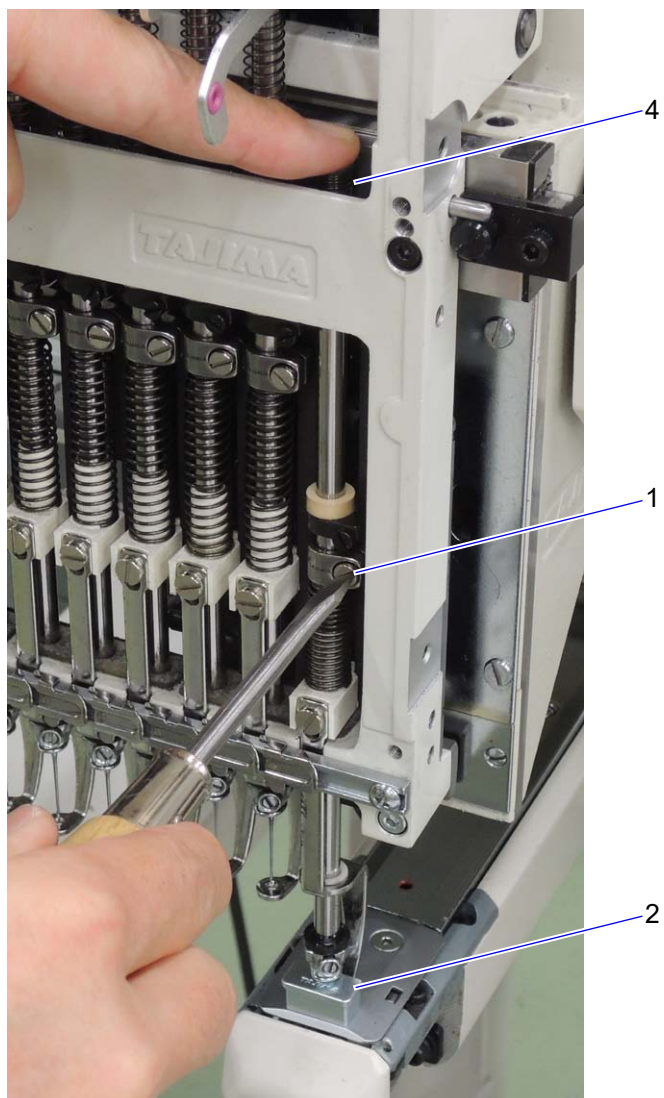
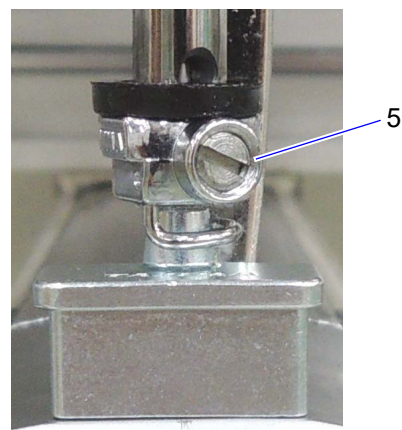
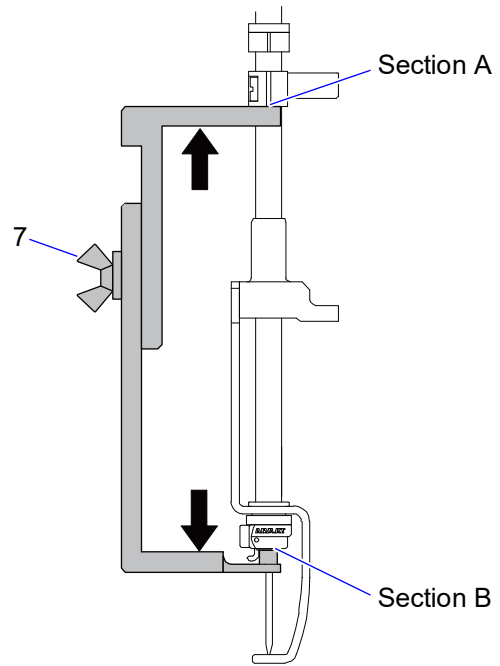
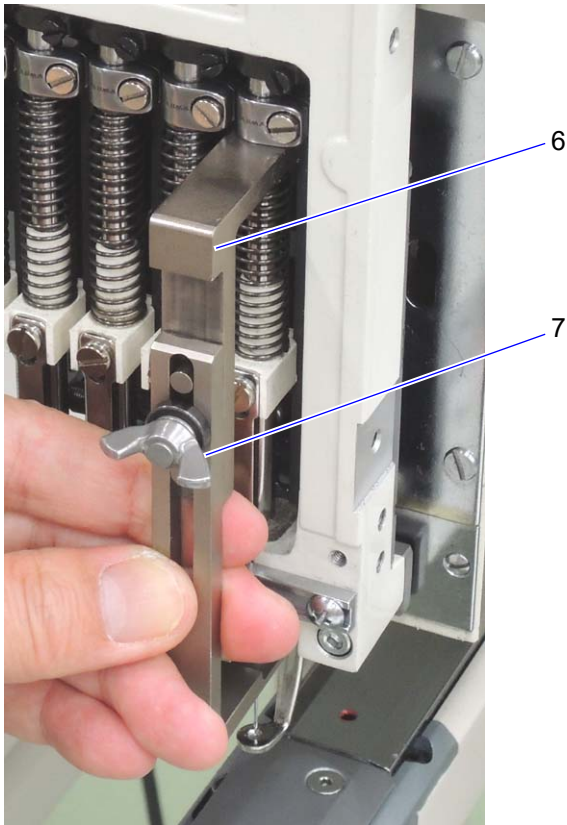

Photo A



- 4 Detach the lower dead point gauge 2.
- 5 Set the main shaft angle to 100° (Stop position).
- 6 Perform Color Change to the next needle bar.

7 Attach the connecting stud gauge 6 to the first needle. Loosen the wing screw 7 and then tighten the wing screw 7 with no gap between sections A and B.



Connecting stud gauge
(GAUGE :NEEDLE BAR CONNECTING STUD[A])
(Part no.: 7Z1402101A00)

8 Attach the connecting stud gauge 6 to the second needle. Loosen the screw 8 and then tighten the screw 8 with no gap between sections A and B. Perform working to the last needle.

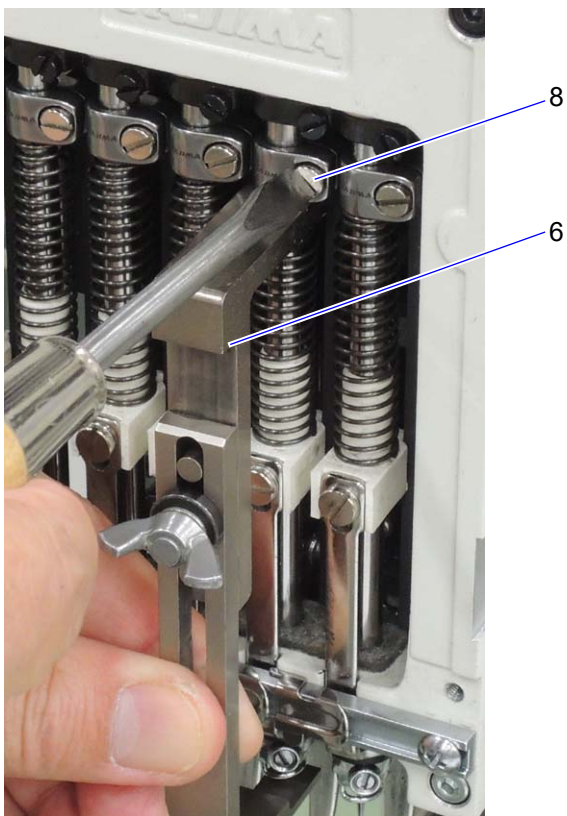

3. Upper dead point

■ TMBR2-SC

The upper dead point adjustment, the usage of "20 Needle bar upper dead point adjustment" in the parameter will facilitate working.

The following example shows how to adjust the upper dead point from the 1st needle in order.

- 1 Change the color to the last needle by operation of the operation panel.
- 2 Follow the procedure below to open the screen of "20 Needle bar upper dead point adjustment" from the parameter.

[P8]→[85. MACHINE ADJUSTMENT]→→[P2]→[20 Needle bar upper dead point adjustment]→



- 3 Press the start switch.

The color change is performed to the 1st needle automatically, then the main shaft stops at the upper dead point (0°).

- 4 Loosen screw 2 of upper dead point stopper 1, and tighten it again with screw 2 facing the front. (1 or 2 in the figure A below)

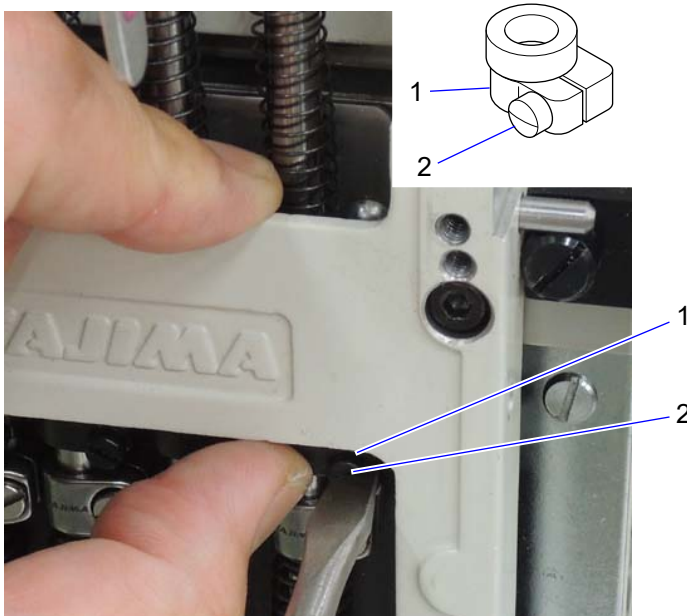
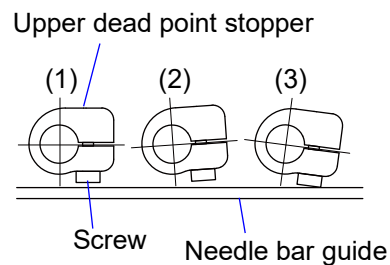



Figure A Viewing from the top



In the state of (3) in the figure A above, the upper dead point stopper touches the needle bar guide, which may cause damage to or failures in parts.

- 5 Press the start switch again.
The main shaft return to the fixed position (100°) automatically, then the color change is performed to the 2nd needle and the main shaft stops at the upper dead point (0°).
- 6 Adjust the upper dead point.
- 7 Adjust the upper dead point for the rest of the needles in the same manner.
- 8 Press  to finish the adjustment.

■ TMBP2-SC, TMBP2-XC

The upper dead point adjustment, the usage of "20 Needle bar upper dead point adjustment" in the parameter will facilitate working.

The following example shows how to adjust the upper dead point from the 1st needle in order.

- 1 Change the color to the last needle by operation of the operation panel.
- 2 Follow the procedure below to open the screen of "20 Needle bar upper dead point adjustment" from the parameter.

[P8]→[85. MACHINE ADJUSTMENT]→→[P2]→[20 Needle bar upper dead point adjustment]→



- 3 Press the start switch.

The color change is performed to the 1st needle automatically, then the main shaft stops at the upper dead point (0°).

- 4 Loosen the screw 2 of the upper dead point stopper 1 and push it up with your thumb, then tighten the screw 2 with it lightly touching the cushion ring 3.

Tighten the screw 2 in the state that it faces the front.

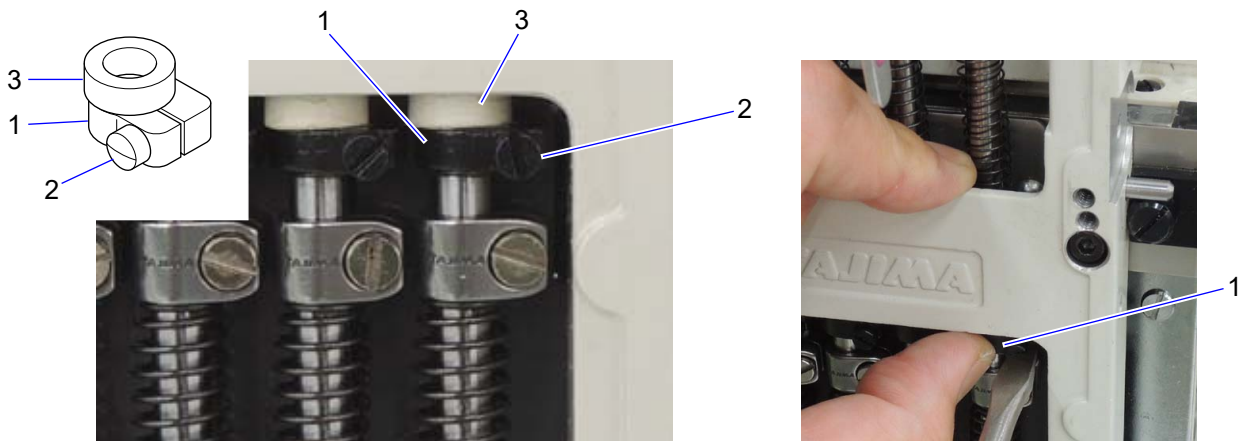

- 5 Press the start switch again.

The main shaft return to the fixed position (100°) automatically, then the color change is performed to the 2nd needle and the main shaft stops at the upper dead point (0°).

- 6 Adjust the upper dead point.
- 7 Adjust the upper dead point for the rest of the needles in the same manner.

- 8 Press  to finish the adjustment.

4. Bevel gear

Check "Play" between the bevel gear 1 and the bevel gear 2. If the bevel gear 2 moves slightly (0.1 to 0.2 mm), "Play" is normal.

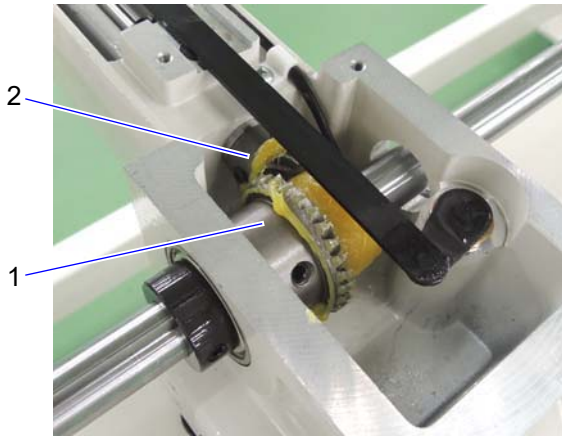

If there is no "play", loosen the set screw of the bevel gear 1 to adjust position of the bevel gear 1.

5. Needle and rotary hook

Perform this checking at the first needle and the last needle.

- 1 Detach the needle plate.
- 2 Lower the needle to the lower dead point in the same way as that for "Needle locating position".
(→ See page 24)
- 3 For TMBR2-SC, TMBP2-SC, turn the main shaft counterclockwise and set it to the position (198° to 202°) where the needle tip 1 meets the hook point 2 of rotary hook.
For TMBP2-XC, turn the main shaft clockwise.
- 4 Check if the gap (A) between the scarf 3 of needle and the hook point 2 of rotary hook is 0.1 to 0.3 mm.

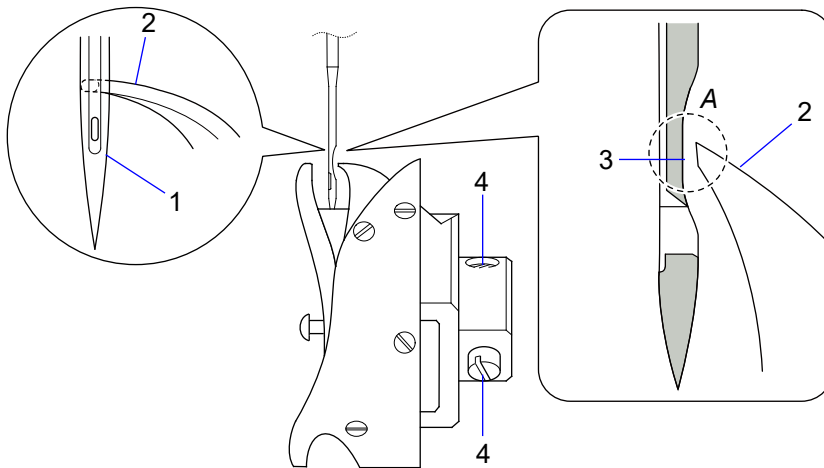

 To adjust in the position of the rotary hook, loosen the three screws 4.

Chapter 7 Idling and test sewing

1. Lubrication

⚠ CAUTION

- ⚠ When performing lubrication, use only Tajima's genuine TF oil (packed with the machine). If you use other oil than this by necessity, select oil equivalent to ISO viscosity grade: VG20.
- ⚠ After the working, attach all covers that were detached.

1-1. Rotary hook

To lubricate the rotary hook, use oiler 1 through lubrication hole 2.

To lubricate the lubrication hole, attach nozzle 3 (accessory) to the tip of the oiler 1.

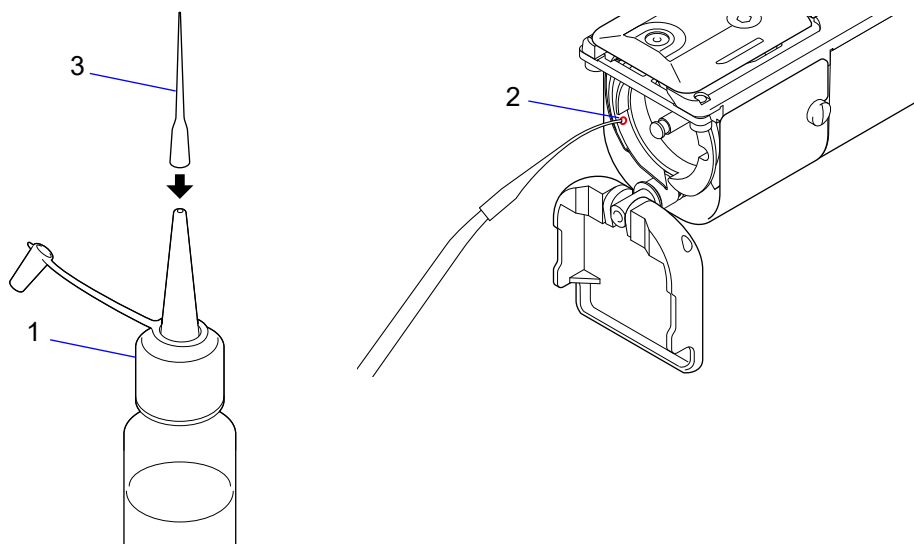

1-2. Inside of arm and cylinder bed

■ TMBR2-SC

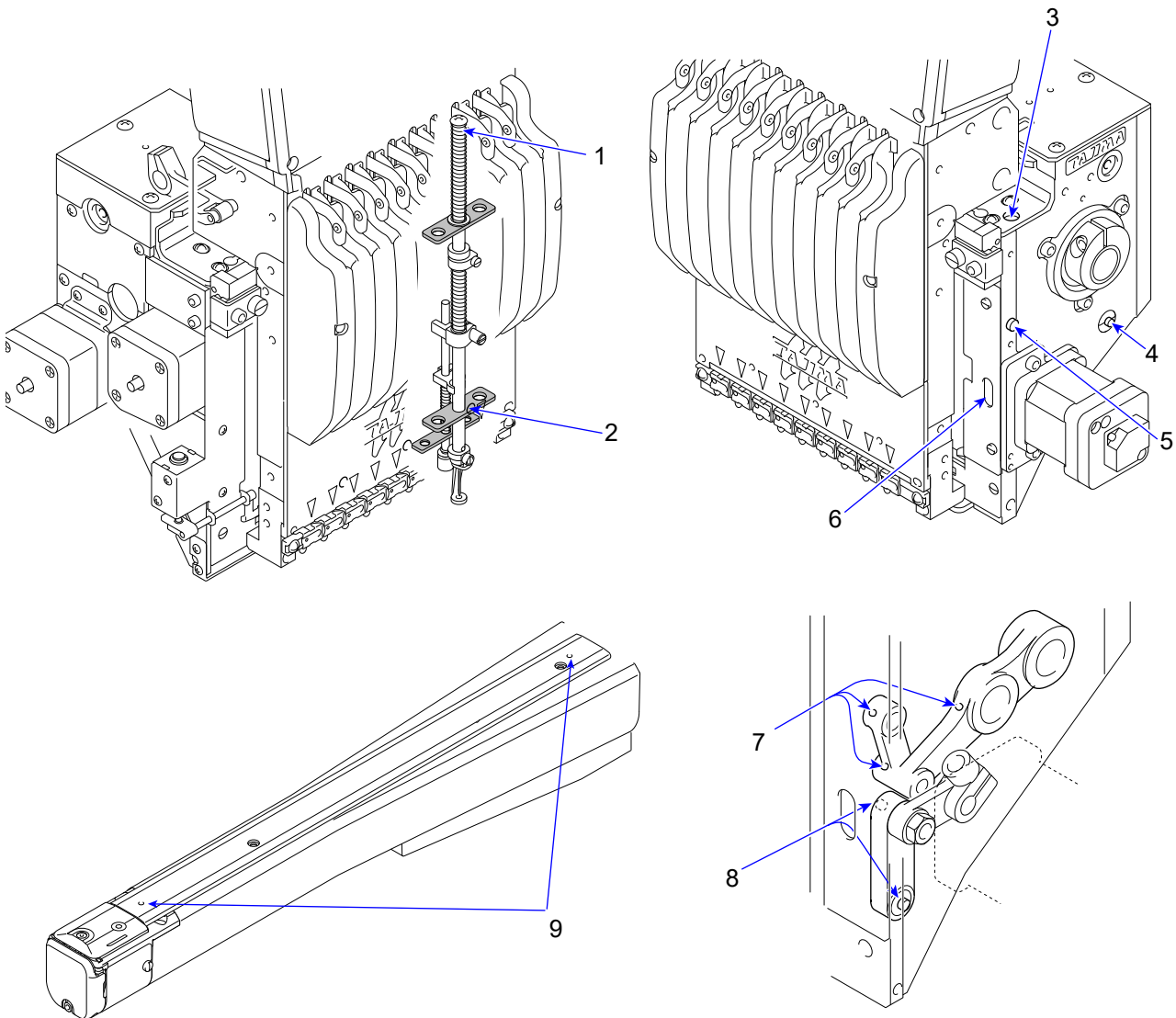

Lubricating spot
1: Needle bar
2: Needle bar
3: Needle bar drive shaft (needle bar side)
4: Wick of stepped pin
5: Wick of arm side (presser foot drive shaft)
6: Needle bar lever, connecting rod
7: Needle bar lever, connecting rod
8: Connecting rod
9: Rotary hook shaft

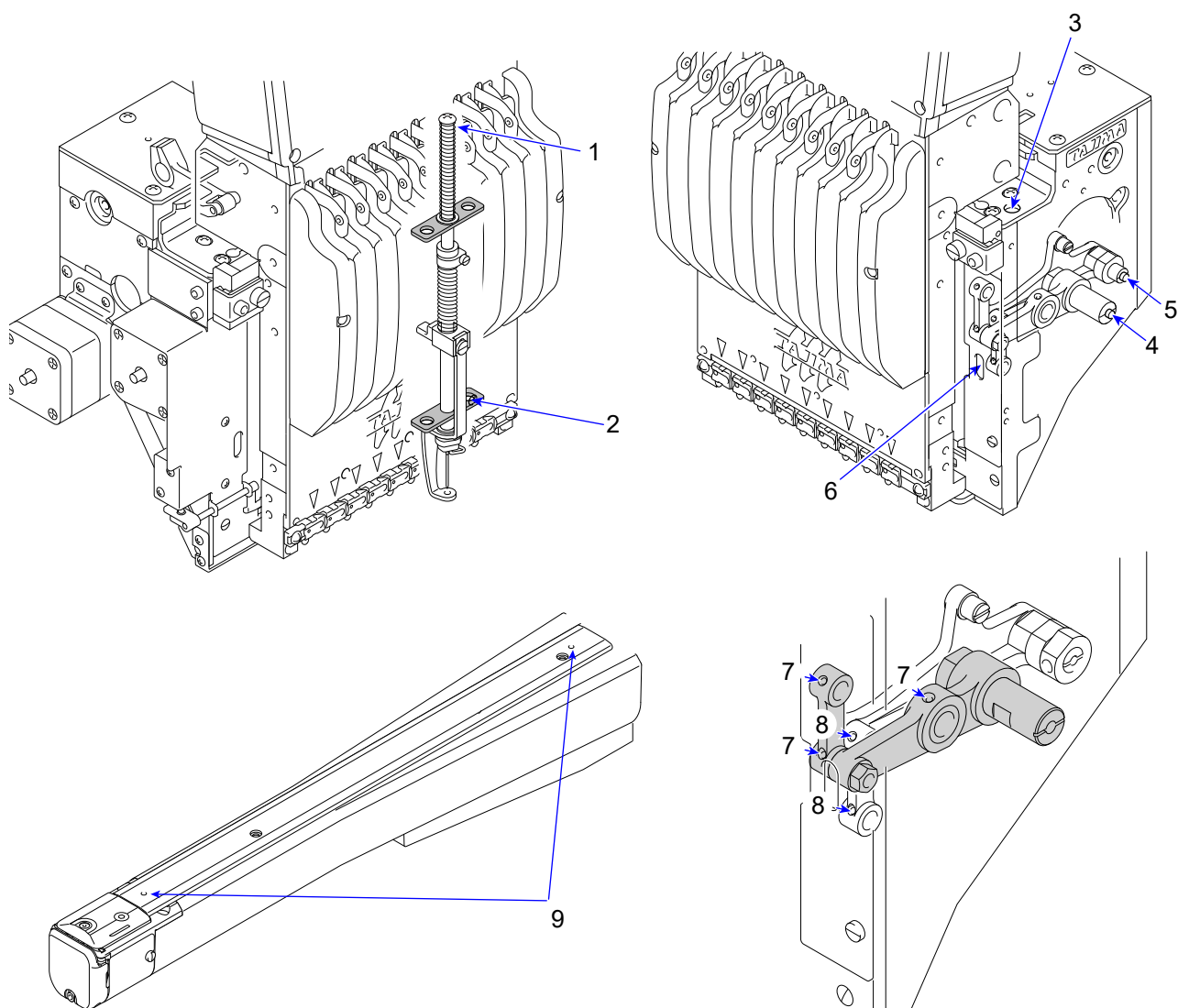

■ TMBP2-SC, TMBP2-XC



Lubricating spot
1: Needle bar
2: Needle bar
3: Needle bar drive shaft (needle bar side)
4: Wick of stepped pin
5: Wick of arm side (presser foot drive shaft)
6: Needle bar lever, connecting rod
7: Needle bar lever, connecting rod
8: Connecting rod
9: Rotary hook shaft

2. Idling, jump

CAUTION

-  When operating the machine, check if there is no person around moving section and all covers are attached to prevent accident resulting in injury or death.
-  Keep on idling until antirust applied on rotary hook is completely removed. If antirust remains, it could cause thread breakage.

- 1 Set "P3-26. Upper thread breakage detection" and "P3-27. Under thread breakage detection" to "Any: 0" in parameter setting.
- 2 Execute the data set of the design data containing jump codes.
- 3 Start the machine to perform idling. In the beginning, start idling from about 250 rpm and increase the number of revolutions to 650 rpm while checking the operating condition of the machine. Devote 20 to 30 minutes to operate the machine. Check if no misjumping occurs for any needle, using design data that includes jump codes.
- 4 When misjumping occurs, it is necessary to adjust the position of the upper dead point stopper.
- 5 After the working, check if no heat occurs from the side part of the arm, the needle bar drive shaft, etc.

8. Threader

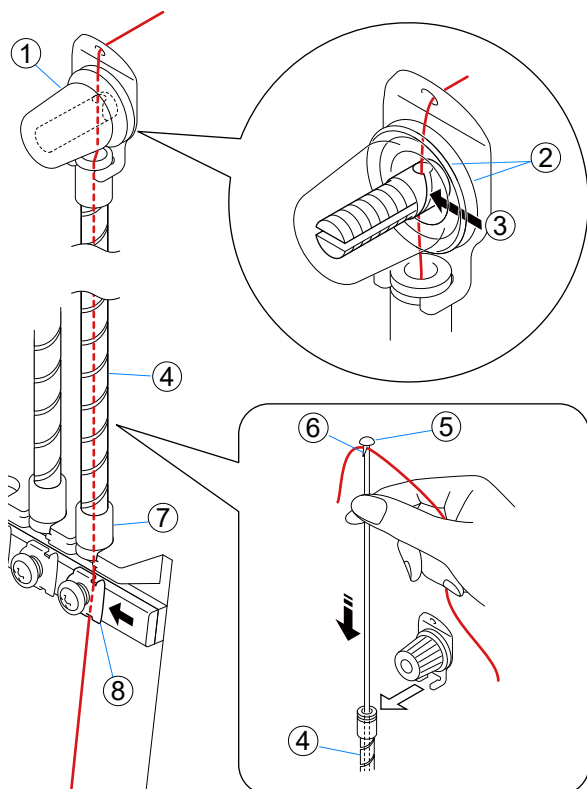

1 Thread tension regulator No. 1 ①

Pass the thread through tension disks ② so that the thread is sandwiched between them, and then pass the thread through groove ③ of the stud.

📖 If you do not pass the thread through the groove, the upper thread may come off the thread tension regulator ① during embroidery.

2 Spiral tube ④

Hook the thread on the hooking part ⑥ of the threader ⑤ (accessory) and insert the thread into the spiral tube ④.

Pull out the threader ⑤ from the tube opening ⑦ fixed to the tension base and pass the thread through the spiral tube ④.

3 Thread presser ⑧

Lift the thread presser ⑧ with your fingers and pass the thread through the thread presser ⑧.

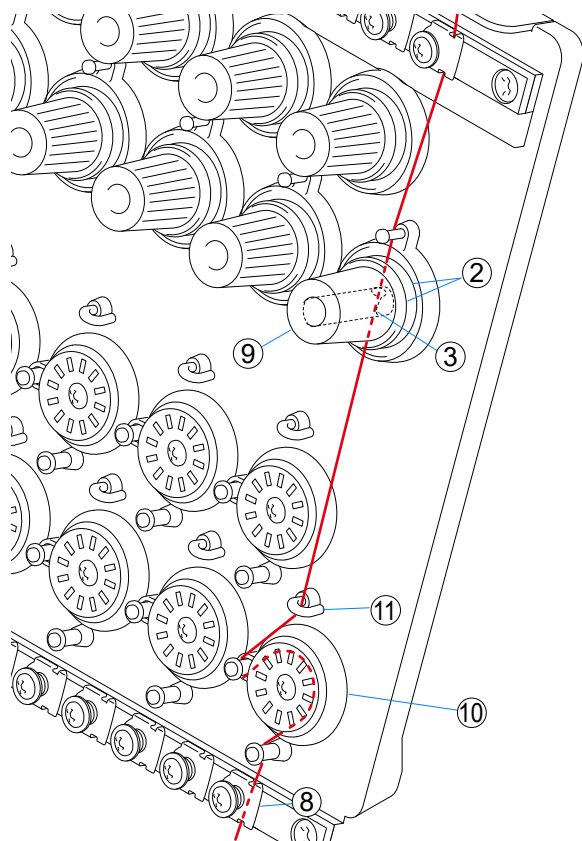

4 Thread tension regulator No. 2 ②

Pass the thread through tension disks ② so that the thread is sandwiched between them, and then pass the thread through groove ③ of the tension stud.

5 Rotary tension disc ⑩

Pass the thread through hook guide ⑪ and rotary disk ⑩.

6 Thread presser ⑧

Lift thread presser ⑧ with your fingers and pass the thread through thread presser ⑧.

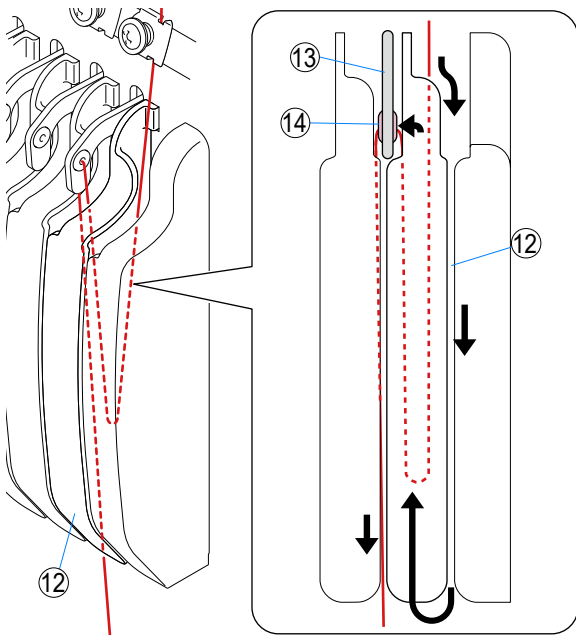

7 Middle thread guide ⑫

After hooking the thread to the middle thread guide ⑫ in the needle bar case, pass the thread into the hole ⑭ of the take-up lever ⑬ from the right-hand side.

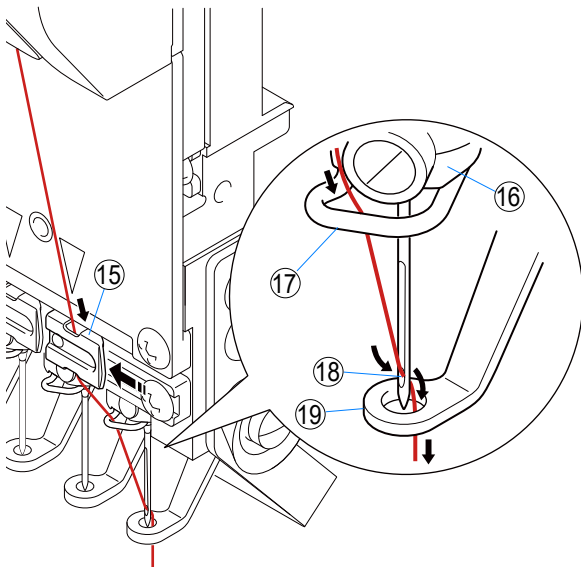

8 Upper thread lock ⑮

Lift the upper thread lock ⑮ with your fingers and pass the thread through the upper thread lock ⑮.

9 Surrounding needle

After passing the thread through the thread holder ⑰ of the needle clamp ⑯, pass the thread from the front of the needle eye ⑱ to the rear.

Furthermore, pass the thread from the needle eye ⑱ to the hole of the presser foot ⑲.

9. Test sewing

Stretch fabric on the frame, set under thread bobbin and check each movement such as color change, manual ATH, etc. Then, start test sewing.

CAUTION

 In order to keep the machine in good condition for a long time, operate the machine at about 70% of the maximum speed for about two weeks as “operation for total fitting” after installation. By performing the operation for total fitting, the life of the machine will become longer, which will be useful to avoid unexpected troubles.

1st edition April 2022

2nd edition February 2024

■ **Manufactured by:**
TISM Co.,Ltd.

Address : NO.1800, Ushiyama-cho, Kasugai, Aichi-pref., 486-0901, Japan
TEL : 81-568-33-1161

■ **Distributed by:**
Tajima Industries Ltd.

Address : NO.1800, Ushiyama-cho, Kasugai, Aichi-pref., 486-0901, Japan
TEL : 81-568-37-1130

●**Copy, reprint, or reform of a part or whole of this manual without permission is prohibited.**