

USER'S MANUAL

MT-1

(Coiling/Taping Device)

TCMX series

Foreword

This manual is a guide book for using option of TAJIMA embroidery machine “MT-1”. Please understand the contents, and then use the option.

This manual may contain discrepancies in detailed information when compared with this device due to difference of target model, continued research and improvements. If any question about the product or contents of this manual arises, please consult your TAJIMA distributor.

Please keep this manual with care near the machine for quick reference.

TISM Co.,Ltd.

Important safety instructions

Items that require your special attention on operation are specified below.



Indicates that there is a lot of danger of death or serious injuries^[*A] if the instruction is not observed.



Indicates that there is a likelihood of death or serious injuries^[*A] if the instruction is not observed.





Indicates a potentially hazardous situation which, if not avoided, may result in minor or moderate injury^[*B] or property damage.

[*A] A condition caused by electric shock, injury, fracture of a bone, etc., that leads to aftereffects, or an injury that necessitates hospitalization or visits to a hospital over a long period.

[*B] An injury that does not necessitate hospitalization or visit to a hospital over a long period.

: Prohibited items

: Items that may cause electric shock if not observed

: Items that must be followed carefully to ensure safe operation

Chapter 1 Coiling

1. Caution	1
2. Name of each part.....	3
3. How to pass thread and tension adjustment	4
3-1. Core thread	4
3-2. Coiling thread	5
3-3. Sewing thread	5
4. Setting for coiling	6
4-1. Turning amount of bobbin.....	6
4-2. Turning direction of bobbin.....	6
5. Stitch type selection on the operation panel.....	7
6. Maximum RPM.....	7

Chapter 2 Taping

1. Caution	8
2. Name of each part.....	9
3. Combination of needle, tape N-Pipe, and needle plate	9
4. How to pass tape.....	10
5. Stitch type selection on the operation panel.....	10

Chapter 3 Attaching/detaching of device

1. Detaching	11
1-1. Coiling device.....	11
1-2. Taping device	11
2. Attaching	12
2-1. Taping device	12
2-2. Coiling device.....	13
3. To return to normal chenille embroidery.....	14

Chapter 4 Operation • setting

1. Setting for coiling	16
2. Bobbin (M-axis)	17
2-1. To turn bobbin (M-axis)	17
2-2. Manual M-axis origin return.....	17
2-3. Manual M-axis Power-ON Restore	18
2-4. M-axis origin offset	19
2-5. M-axis retracting position.....	19
2-6. M-axis origin search when data is set.....	20
2-7. M-axis power restore when turning ON the power	20
3. Re-setting after installing the software	21

Chapter 5 Coping with bad sewing

1. Coiling	22
2. Taping	22

Chapter 1 Coiling

1. Caution

! CAUTION

- ! When you perform coiling, consider thickness of core thread etc.^[*1] Select needle height so that the tip of needle is higher than the material to sew when the needle bar comes to the position of upper dead point. Although standard needle height is "4", change the height according to material to use.

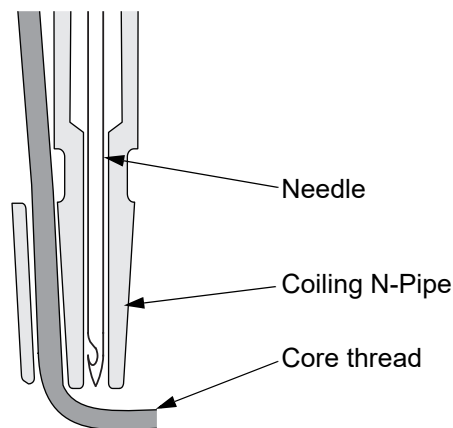

- ! Make radius as large as possible in curve or circle design.
- ! In case of coiling, use embroidery data containing constant pitch of chain stitch (sewing pitch). If sewing pitch changes in the middle of embroidery, it could cause breakage of needle and/or bad coiling. Basic sewing pitch in a design consisting of only moderate curved lines and/or straight lines is 1.5 mm and parallel pitch is 1.2 mm^[*2].

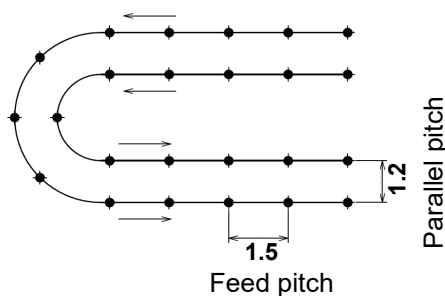

- ! Although it differs depending on the thickness of the material to be sewn, overlapping of the material should usually be one fold. Two or more folds could cause thread breakage and/or breakage of needle.

[*1] Although it is possible to use core thread of thickness up to about 1 mm, it depends on material. Pass core thread to coiling N-Pipe and check if it passes smoothly before use.

[*2] The basic sewing pitch applies to the following conditions. It is necessary to adjust sewing pitch depending on thread type.
Coiling thread: rayon 300/2 Two pieces
Core thread: cotton spun #18/2 One piece

CAUTION

- ! At beginning of sewing, fix the core thread and coiling thread by using adhesive tape after lowering the needle bar. It prevents occurrence of bad sewing.

Core thread

Coiling thread

Fix using tape.

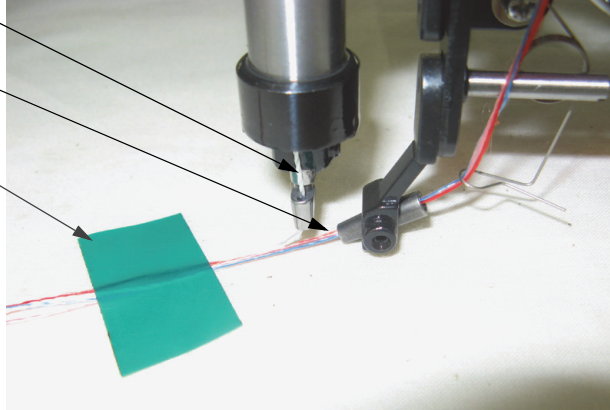

2. Name of each part

Coiling device mainly consists of the following 1 to 7 parts.

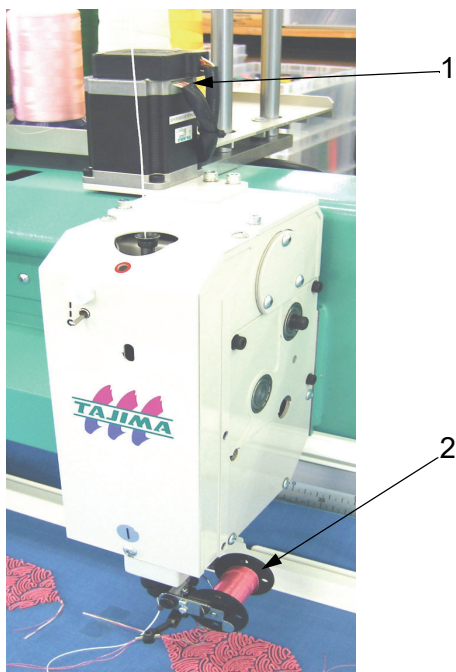

Names of the following parts are abbreviated. For details, please refer to the separate parts list.

1. Pulse motor
2. Coiling bobbin
3. Coiling N-Pipe
4. Coiling thread course
5. Auxiliary spring
6. Cord guide
There are several types in size. For details, please ask the distributor for information.
7. Spring for core thread

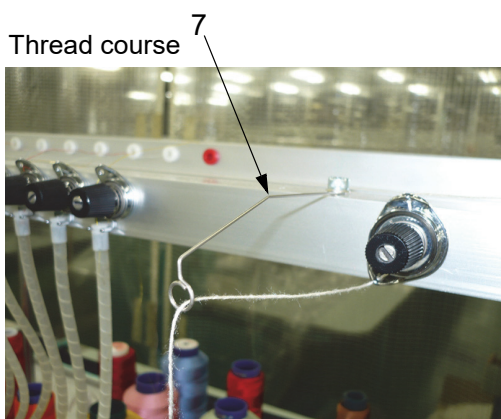
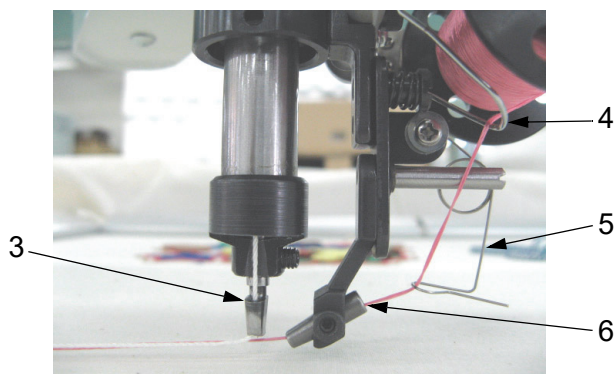

3. How to pass thread and tension adjustment

3-1. Core thread

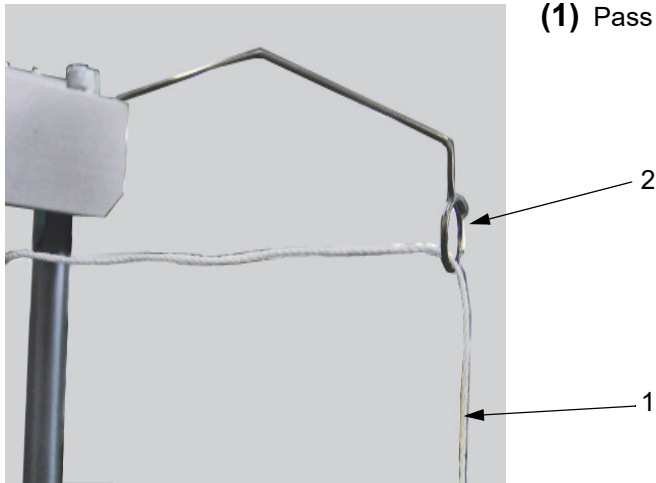

(1) Pass the core thread 1 to the spring 2.

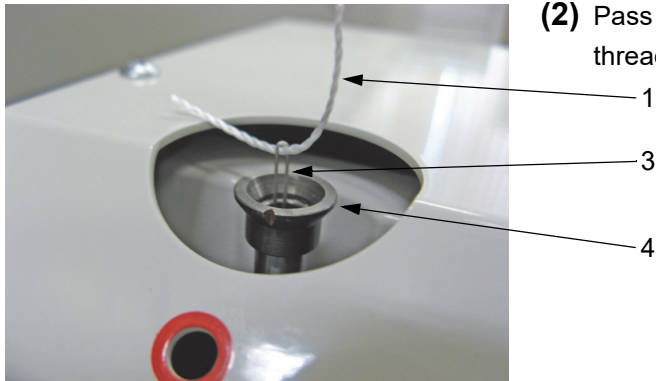

(2) Pass the core thread 1 into the needle bar 4 by using the threader 3 (accessory).

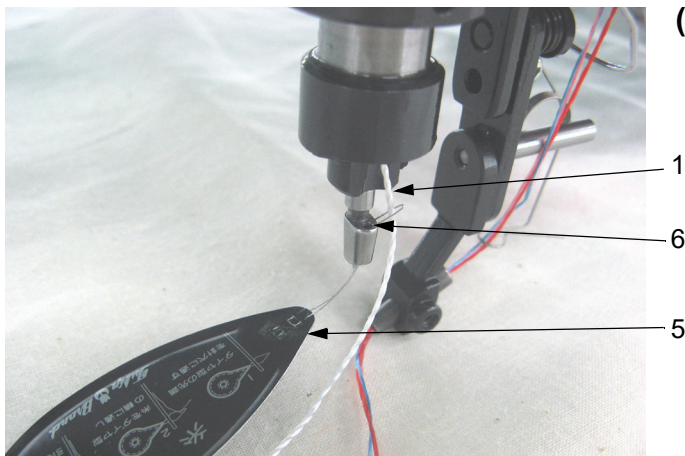
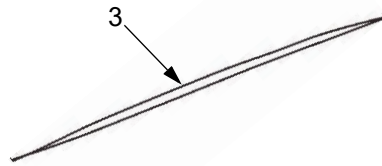

(3) Pull out the core thread 1 from the bottom of the needle bar and pass it to the N-Pipe hole 6 by using the threader 5 (accessory).

Adjust tension in the state that the core thread is passed in the N-Pipe so that the core thread flows smoothly. When you desire to obtain beautiful design line, make tension stronger. When sewing thread appears on the fabric, make tension weaker.

3-2. Coiling thread

Refer to the figure below to pass the coiling thread 1 to the device. Set tension so that the auxiliary spring 2 returns lightly when you rotate the bobbin by hand or stretch the coiling thread. To adjust tension, use the screw of the bobbin or change the fixing position of the auxiliary spring 2 by using the screw 3.

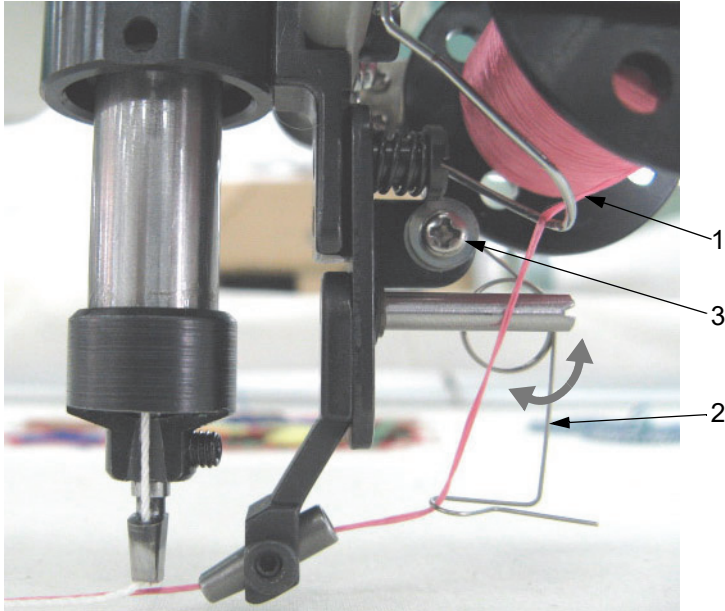

3-3. Sewing thread

When tension of chain stitch is set a little bit stronger than usual one, it is hard for sewing thread to appear on the material at corner section. Perform adjustment according to material to sew.

4. Setting for coiling

It is possible to vary finishing of sewing by the following setting.

4-1. Turning amount of bobbin

By changing turning amount of bobbin against one stitch (1/1, 1/2, 1/3, 1/4), finishing of sewing varies (=>p.16).

4-2. Turning direction of bobbin

Turning direction of bobbin (CW, CCW)^[*1] differs depending on material to use and/or creating method of design data. Therefore, set turning direction accordingly (=>p.16).

Figure A

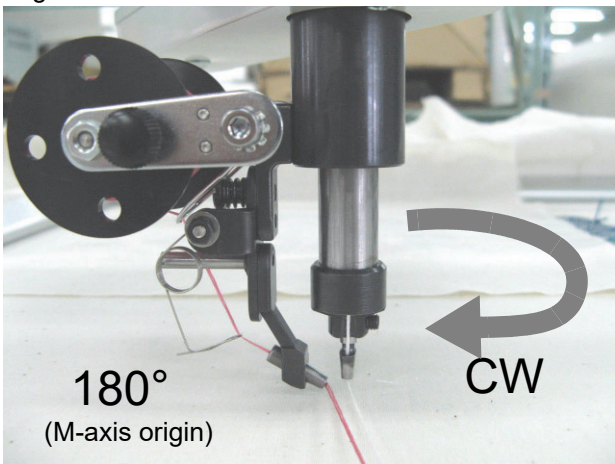
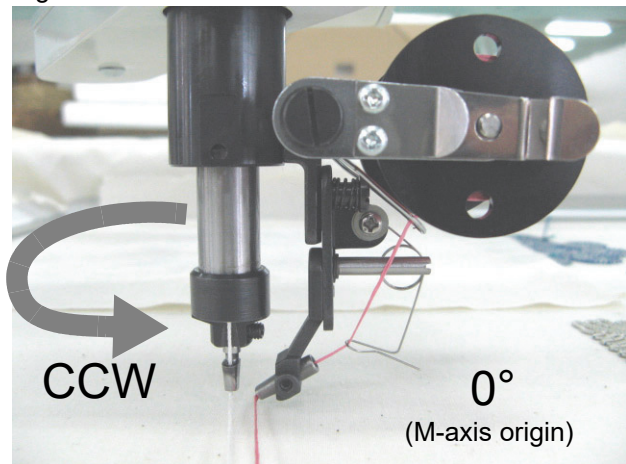

Figure B



In addition, after changing turning direction of bobbin, set "Stand-by position of bobbin" again (chart below).

Turning direction of bobbin	Stand-by position of bobbin (M-axis Origin Offset =>p.19)
CW	180° (Refer to the figure A above)
CCW	0° (Refer to the figure B above)



The value described left is standard (It is possible to change value at your option in 360°).

[*1] CW: clockwise, CCW: counterclockwise

5. Stitch type selection on the operation panel

Select "M" in "2 Auto Stitch Type Selection"^[*1] when performing "Coiling" in step.



M: Coiling
T: Taping
L: Loop
C: Chain



"M" and "T" are displayed only when "M-axis" is set to "YES" (=>p.21).

6. Maximum RPM

RPM at coiling is limited as shown below.

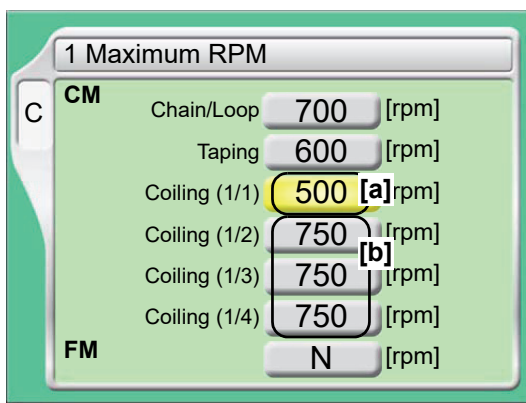

[a] Up to 500 rpm. It is not possible to exceed 500 rpm for setting.

[b] It is possible to set values up to the Max. Revolution Limit (SET+F2).

Chapter 2 Taping

1. Caution

CAUTION

- ! When you perform taping, consider thickness of material^[*1] to sew. Select suitable needle height so that the tip of needle is positioned higher than the material to sew when the needle bar comes to the position of upper dead point.

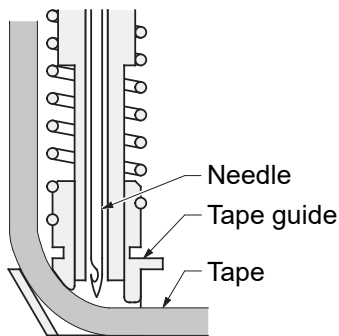

- ! In case of taping, use embroidery data containing constant pitch of chain stitch (sewing pitch)^[*2]. If sewing pitch changes in the middle of taping, it could cause breakage of needle and/or bad taping.

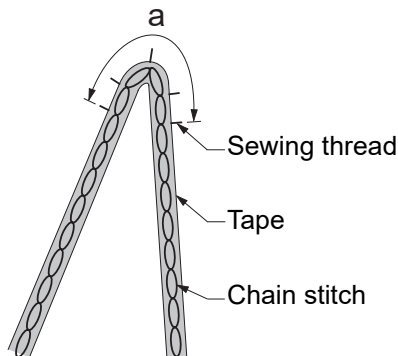

- ! Although it differs depending on the thickness of the material to be sewn, overlapping of the material should usually be one or two folds. If the material is overlapped three times or more, it could cause breakage of thread or needle.

[*1] Although it is possible to use material of thickness up to about 5 mm, it depends on type or quality. Pass the material to the tape guide and check if it passes smoothly without catching with needle.

[*2] If a design consists of moderate curved lines and/or straight lines only, it is no problem to use large stitching interval (2.5 to 3 mm). However, if degree of curve of curved line is keen, sewing thread will not become tight. That causes the material to be pulled as if it were lifted (refer to section a in the figure above). If a design includes keen curved line(s), apply smaller stitching interval (1.5 to 2 mm).

2. Name of each part

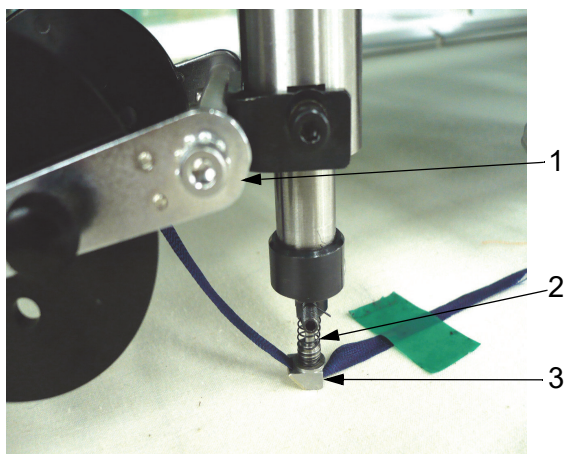

1. Taping attachment
2. Tape N-Pipe (chart A below)
3. Tape guide
There are several types in size. For details, please ask the distributor for information.

Chart A

Size of tape N-Pipe

Needle size	1	2	3	4	5	6	7	8	9
Inner diameter (mm)	0.7	0.8	0.9	1.0	1.1	1.2	1.3	1.4	1.5

3. Combination of needle, tape N-Pipe, and needle plate

When replacing needle depending on type of sewing thread and/or fabric, replace also tape N-Pipe and needle plate referring to the chart below.

Needle		Tape N-Pipe (inner diameter)	Needle plate (Diameter)
Organ count No.	Needle diameter		
#11	0.75 mm	0.9mm	1.4 mm
#14	0.9mm	1.2 mm	
#16	1.0 mm	1.3 mm	1.6 mm
#18	1.1 mm	1.4 mm	1.8 mm

4. How to pass tape

Refer to the figure below to pass the tape 1 to the tape guide 2. After that, apply tension to the bobbin 4 by using the screw 3 so that the bobbin does not run idle.

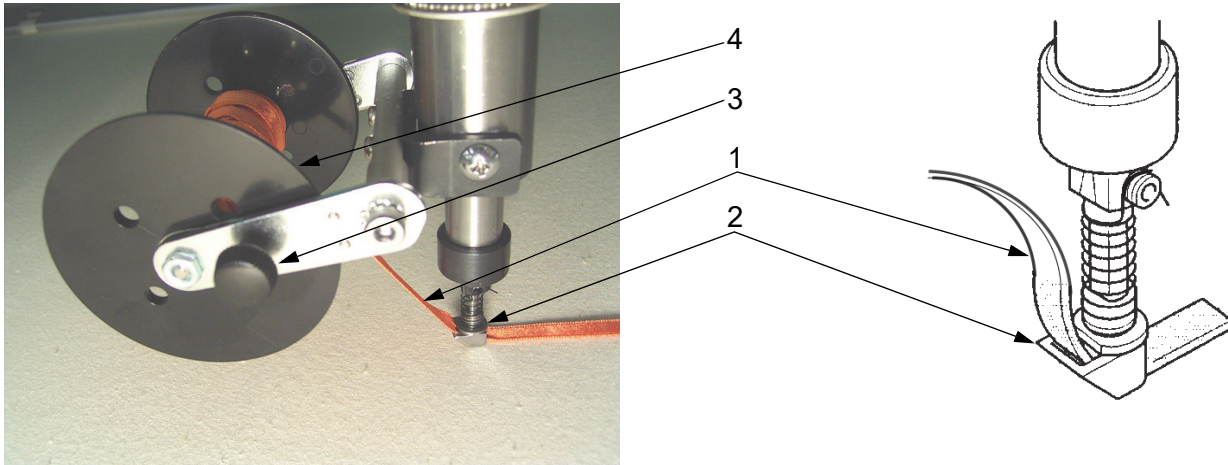

5. Stitch type selection on the operation panel

Select "T" in "2 Auto Stitch Type Selection"^[*1] when performing "Taping" in step.



M: Coiling
T: Taping
L: Loop
C: Chain



"M" and "T" are displayed only when "M-axis" is set to "YES" (=>p.21).

[*1] Press B key.

Chapter 3 Attaching/detaching of device

1. Detaching

1-1. Coiling device

- (1) Remove the screw 1 (M4*12) to detach the attachment 2.
- (2) Loosen the screw 3^[*1] to detach the coiling N-Pipe 4.

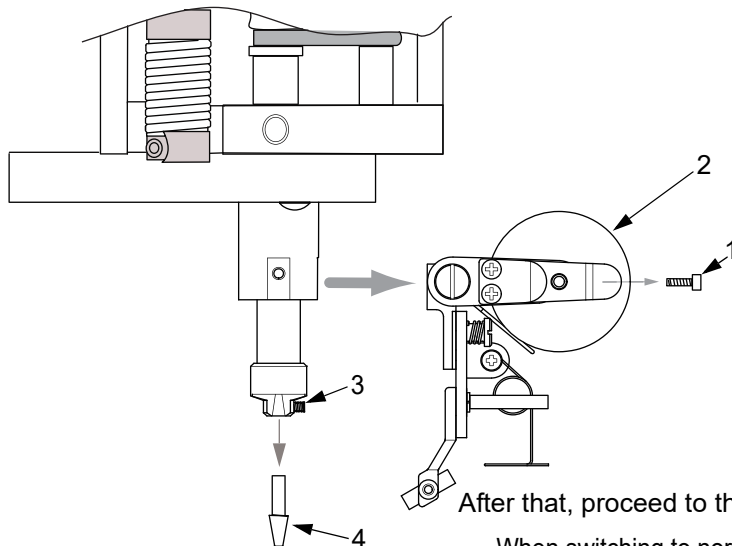

When switching to normal chenille embroidery: Go to 3. of p.14.
When switching to taping: Go to 2-1. of p.12.

1-2. Taping device

- (1) Remove the screw 1 (M4*8) to detach the attachment 2.
- (2) Remove the screw 3^[*1] to detach the tape N-Pipe 4 and tape guide 5.

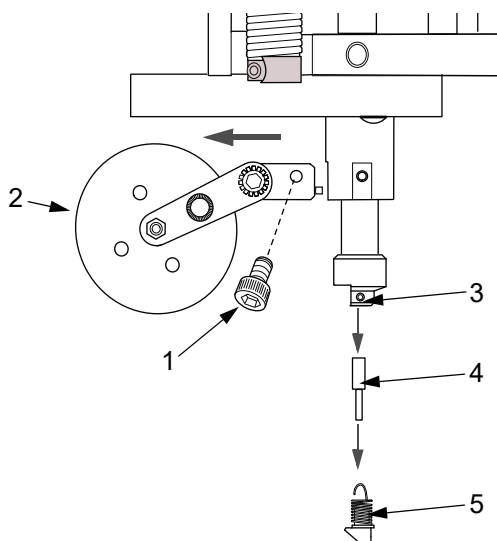

When switching to normal chenille embroidery: Go to 3. of p.14.
When switching to coiling: Go to 2-2. of p.13.

[*1] Size of screw 3 differs depending on stitch type.
In case of coiling, normal chenille embroidery: M4*4
In case of taping: M4*8

2. Attaching

2-1. Taping device

- (1) Attach the taping attachment 1 to the N-Pipe sleeve 2, and tighten the screw 3 (M4*8).
- (2) Replace with the tape N-Pipe 4 complying with sewing thread, and fix the screw 5 (M4*8)^[*1] temporarily. At this moment, replace also needle and needle plate to accommodate the size of 4 (=>p.9).
- (3) Refer to the following "2-1-1." to adjust the position of 4.
- (4) Insert the tape guide 6 to 4, and hang the edge of the spring on the screw 5. After that, refer to "2-1-2." of p.13 to adjust the position of 6.

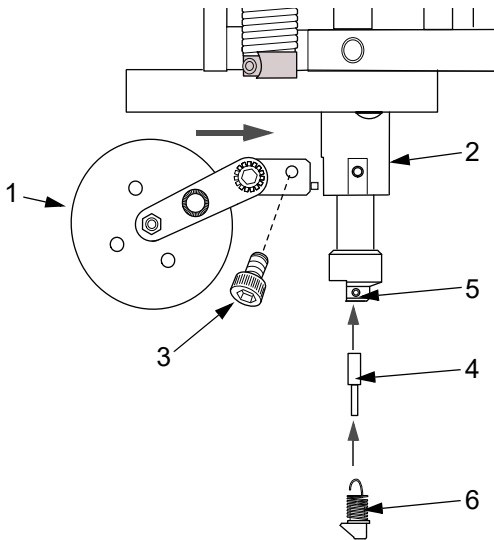

2-1-1. Height adjustment of tape N-Pipe

- (1) Set needle height to Low position (any one of 0 to 9) by "2 Manual height selection" (pressing F5 key).
- (2) Turn "OFF" the power and turn the main shaft to around the lower dead point (250°).
- (3) Align the direction of the tape N-Pipe 4 with the N-Pipe connecting stud 8, tighten the screw 5 (M4*8) so that there is no gap (A) between 4 and needle plate 7.

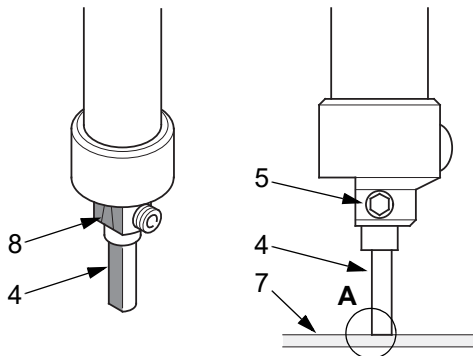

[*1] Size of screw 5 differs depending on stitch type.

In case of taping: M4*8

In case of coiling, normal chenille embroidery: M4*4

2-1-2. Fixing of tape guide

- (1) Turn the main shaft counterclockwise to raise the tape N-Pipe 4.
- (2) Screw the spring 9 in the screw section 8 of the tape guide 6. Insert 6 with 9 to the tape N-Pipe 4, and hang the hook 10 on the screw 5.
- (3) Turn the main shaft counterclockwise by hand to set it to the position of 100 degrees (fixed position).
- (4) Adjust screwing amount of the spring 9 so that the bottom of the tape guide 6 touches the fabric.

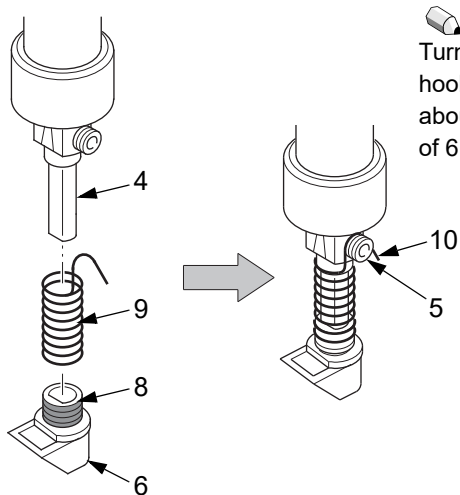

Turning the spring 9 to right or left direction by one turn after detaching the hook 10 from the screw 5 will cause the tape guide 6 to move up/down by about 1 mm. When stroke of 6 during operation is large, lower the position of 6 slightly.

2-2. Coiling device

- (1) Attach the coiling attachment 1 to the N-Pipe sleeve 2, and tighten the screw 3 (M4*12).
- (2) Replace with the coiling N-Pipe 4 and adjust the position of 4 (size of the screw 5 is M4*4). Adjusting method is the same as "Height adjustment of tape N-Pipe". Refer to "2-1-1." of p.12.
- (3) Replace with needle plate of which hole diameter is 1.4 mm.

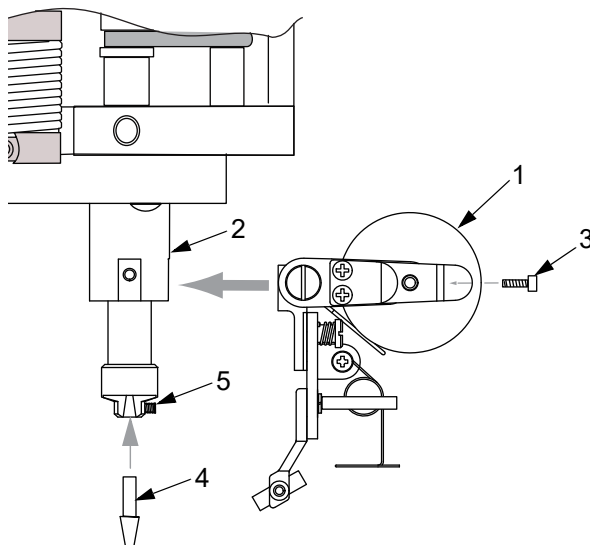

Attach 4 to the direction as shown in the figure below.

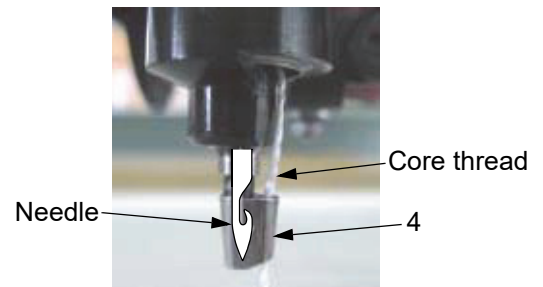

3. To return to normal chenille embroidery

- (1) Replace with the N-Pipe 1 complying with sewing thread, and tighten the screw 2 (M4*4)^[*1]. At this moment, replace also needle and needle plate to accommodate the size of 1 (=>p.9).
- (2) After fixing the presser foot 3 to the rod 4 by using the clamp 5 and screw 6, insert the presser foot 3 to the presser foot bracket 7 and tighten the screw 8.

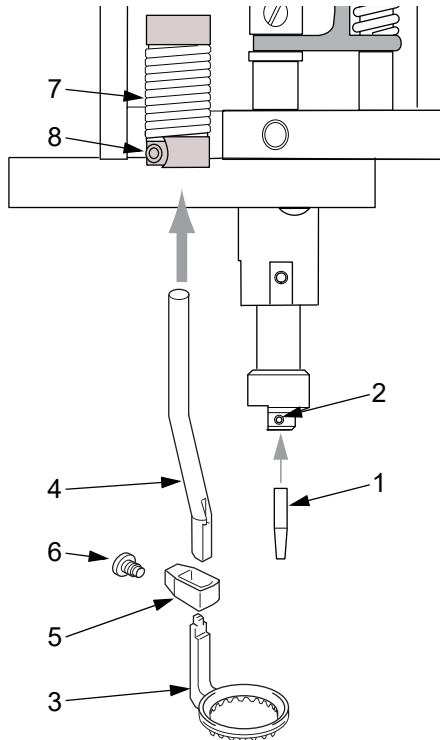

(3) Height adjustment of N-Pipe

- [a] Set needle height to Low position (any one of 0 to 9) by “2 Manual height selection” (pressing F5 key).
- [b] Turn “OFF” the power, and turn the main shaft to set it near to the lower dead point (250°).
- [c] Loosen the screw 2 so that there is no gap (A) between the tape N-Pipe 1 and needle plate 9, and adjust height of 1.

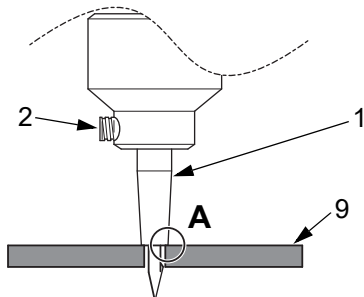

[*1] Size of screw 2 differs depending on stitch type.

In case of coiling, normal chenille embroidery: M4*4

In case of taping: M4*8

(4) Height adjustment of presser foot

[a] Set needle height to Low position (any one of 0 to 9) by “2 Manual height selection” (pressing F5 key).

[b] Loosen the screw 8 to adjust height of the presser foot 3 so that 3 presses the fabric firmly.

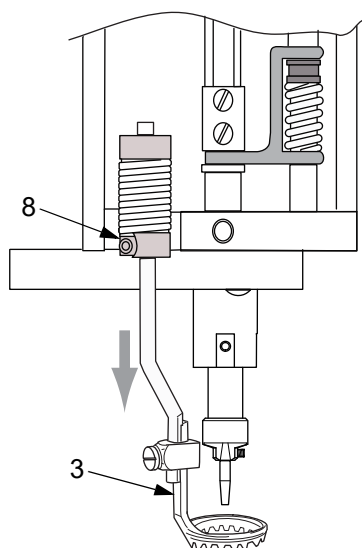

Chapter 4 Operation • setting

1. Setting for coiling



It is possible to set only when M-axis is set to "YES"(>=>p.21).

(1) To call the screen

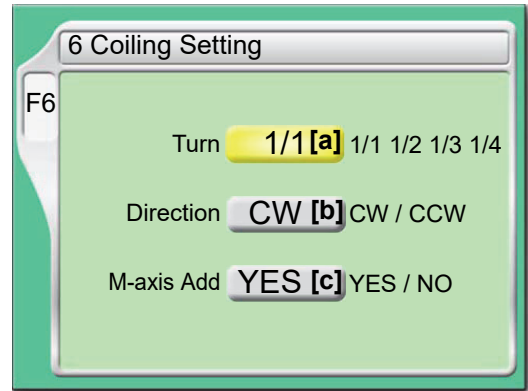
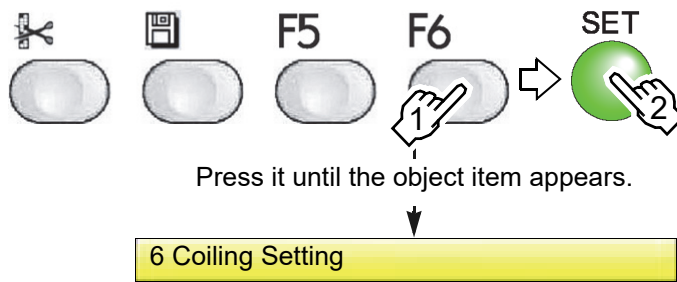

<Explanation on the screen>

[a] Rotating amount of bobbin against one stitch

1/1: Rotating by 360°

1/2: Rotating by 180°

1/3: Rotating by 120°

1/4: Rotating by 90°

1/1



1/2

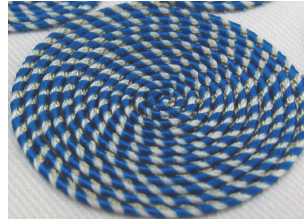

1/3



1/4



[b] Turning direction of bobbin

CW: clockwise, CCW: counterclockwise

[c] To optimize bobbin turning against frame travel direction

* Select YES.

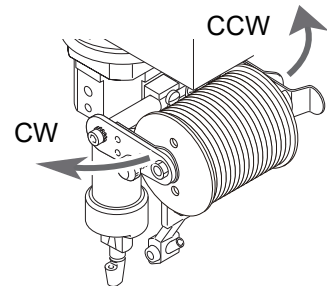

(2) Select a value and [SET].

* The following indicates values at shipment from the factory.

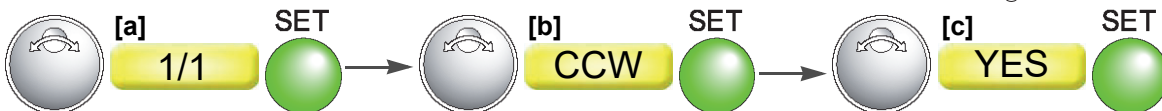

2. Bobbin (M-axis)

2-1. To turn bobbin (M-axis)

Rotate bobbin of MT-1 by manual operation.



In case of mixed type series, it is effective only when CM head is selected.

It is possible to operate only when M-axis is set to "YES" (=>p.21).

- (1) Set the screen to the main screen.
- (2) Turn the jog shuttle 1 or jog dial 2 while pressing SET.

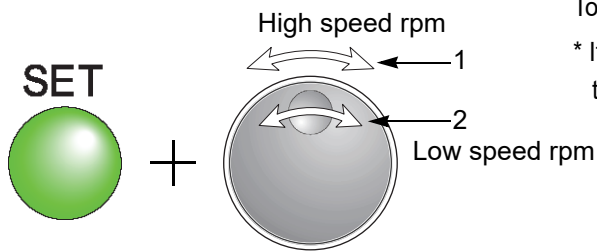

To return to the original state, perform operation of "2-2."

* It is possible to start the machine from the position after turning the bobbin.

! CAUTION

⊘ Do not put your hands etc. near needle. Turning bobbin could injure you.

2-2. Manual M-axis origin return

This operation returns M-axis to the origin^[*1] by manually.



In case of mixed type series, it is effective only when CM head is selected.

It is possible to operate only when M-axis is set to "YES" (=>p.21).

- (1) To call the screen

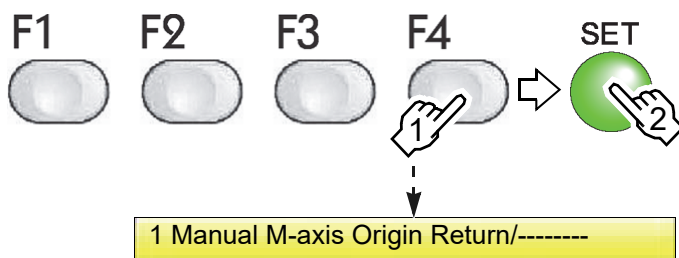

<Explanation on the screen>

[a] — : Not to execute, ○ : To execute

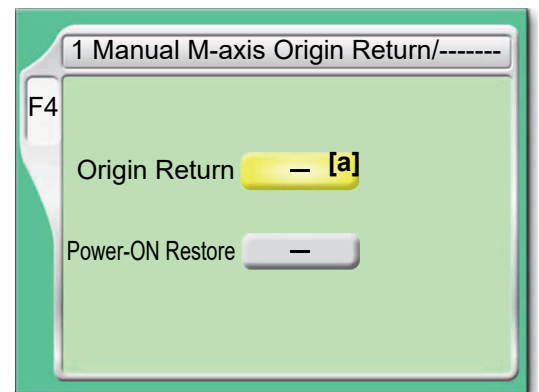

- (2) Select "O" to [SET].

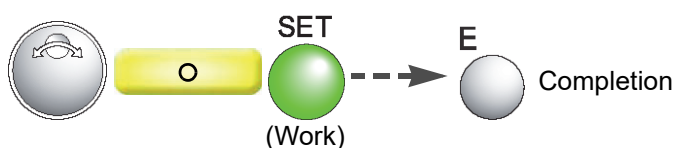

! CAUTION

⊘ Do not put your hands etc. near needle. Turning bobbin could injure you.

[*1] The position to which bobbin rotates and stops just after data set and at thread breakage

2-3. Manual M-axis Power-ON Restore

When detected angle of bobbin is misaligned^[*1], this operation returns the bobbin to the previous angle before misalignment by manual operation.



In case of mixed type series, it is effective only when CM head is selected. It is possible to operate only when M-axis is set to "YES" (=>p.21).

! CAUTION

Do not put your hands etc. near needle. Turning bobbin could injure you.

(1) To call the screen

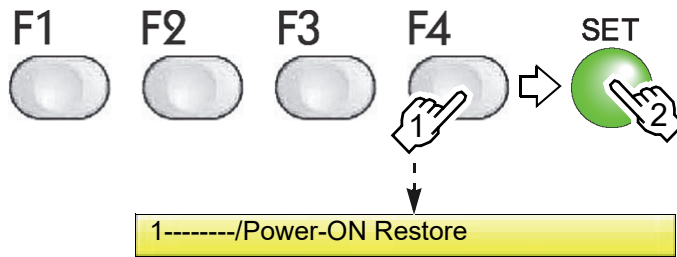

<Explanation on the screen>

[a] — : Not to execute, O : To execute

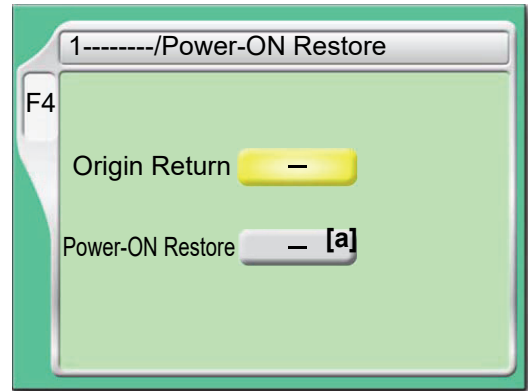

(2) Move down the cursor and select "O" to [SET].

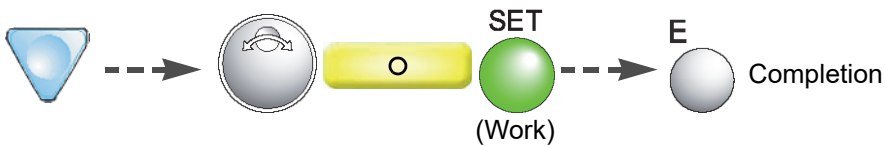

[*1] In such a case as when bobbin was moved by hand with the power turned OFF

2-4. M-axis origin offset

Set stand-by position^[*1] of bobbin.



It is possible to change finishing of sewing by this setting.
It is possible to set only when M-axis is set to "YES" (=>p.21).

(1) To switch screen

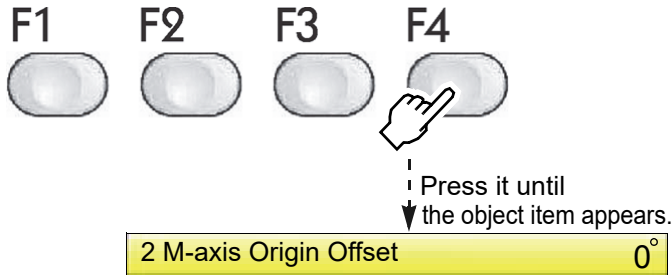

(2) Select a value and [SET].

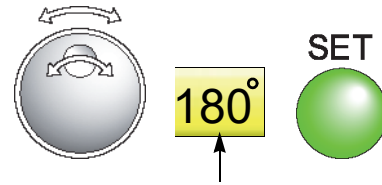

It indicates M-axis angle (direction of bobbin).
Select a value according to turning direction of bobbin.

In case of CW: 180
In case of CCW: 0

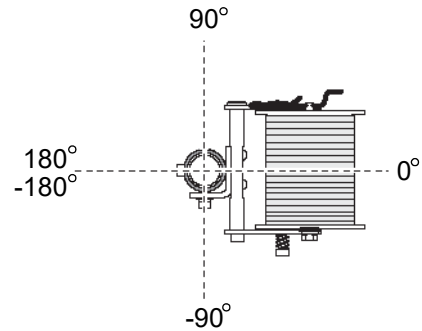

This figure is common to "2-4." and "2-5."

2-5. M-axis retracting position

Set a retracting position^[*2] of bobbin.



It is possible to set only when M-axis is set to "YES" (=>p.21).

(1) To switch screen

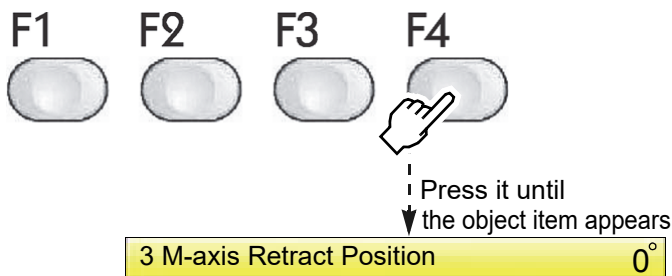

(2) Select a value and [SET].

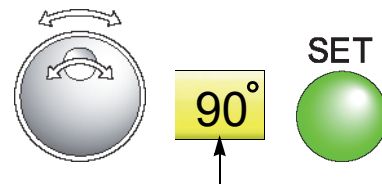

It indicates M-axis angle (direction of bobbin) (0° or 90°).

* Refer to the figure of "2-4."

[*1] The position to which bobbin rotates and stops just after data set and at thread breakage

[*2] Direction of bobbin at suspended head (thread breakage indicator lamp is unlit)

2-6. M-axis origin search when data is set

This setting detects M-axis angle after data set and returns bobbin to the stand-by position^[*1].



It is possible to set only when M-axis is set to "YES" (=>p.21).

- (1) To perform the following operations from the main screen

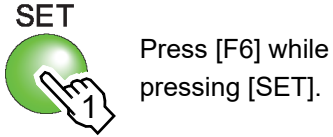

Press [F6] while pressing [SET].

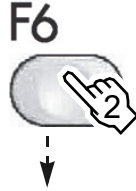

- (2) Select "YES" and press [SET].



1 M-axis Origin Search at Data Setting NO

2-7. M-axis power restore when turning ON the power

This setting returns bobbin to the correct angle (original position) by detecting M-axis angle when the power is turned ON.



It is possible to set only when M-axis is set to "YES" (=>p.21).

Use this function in such a case as when M-axis is misaligned due to turning of the bobbin by hand at power turned OFF. It is effective only when misaligned angle against the correct angle is less than 180°.

- (1) To perform the following operations from the main screen

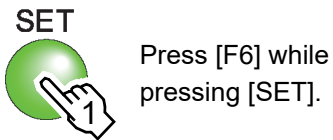

Press [F6] while pressing [SET].



- (2) Select "YES" and press [SET].

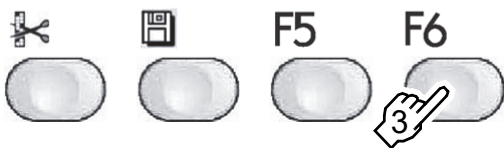
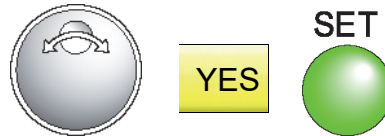

Press [F6] until the object item appears.

2 Auto M-axis Power-ON Restore NO

[*1] The position to which bobbin rotates and stops just after data set and at thread breakage

3. Re-setting after installing the software

After installing the software, "M-axis" in the figure below will be set to "NO". Therefore, set to "YES" again.
* For details, please refer to the user's manual of the machine.

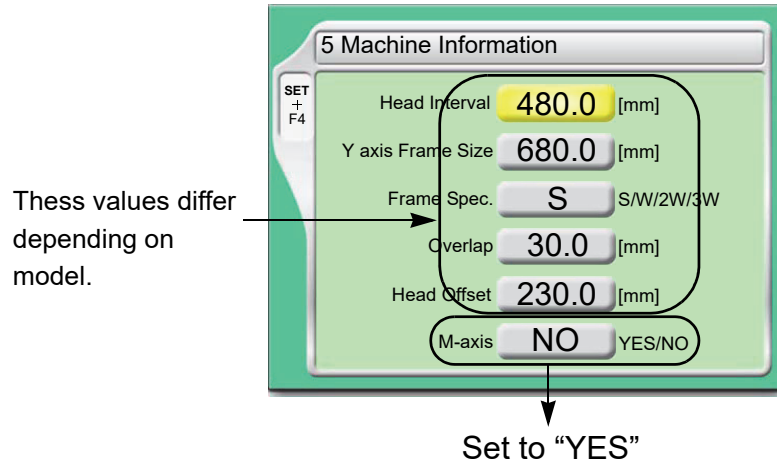

Chapter 5 Coping with bad sewing

1. Coiling

Symptom	Cause	Adjustment
Core thread is seen through coiling threads.	Sewing pitch is large.	Make sewing pitch smaller.
	Core thread is thick.	Use thinner core thread.
	Amount of coiling thread is small.	Increase amount of coiling thread.
Sewing thread is pulled by the material and made visible on the fabric surface.	Needle height is too high.	Lower needle height a little. Increase tension of sewing thread.
	Tension of core thread is too strong.	Adjust first tension to weak thread tension.
The material to be sewn is pulled by the needle.	The needle catches the material during frame feed since the needle front tip is not above the material upper face when the needle bar is at the upper dead point.	After making needle height higher by 2 to 3 positions, perform adjustment by lowering needle height gradually while performing test sewing.

2. Taping

Symptom	Cause	Adjustment
The needle does not locate to the center of the material to be sewn.	Direction of tape guide does not match with direction of frame feed.	Correct direction of tape N-Pipe.
The material to be sewn comes off.	Width of tape guide does not match with width of material to be sewn.	Replace tape guide with one that matches with tape width.
Sewing thread is pulled by the material and made visible on the fabric surface.	Stitching interval is too big.	Make stitching interval of embroidery data smaller.
	Needle height is too high.	Lower needle height a little. Increase tension of sewing thread.
	Tension of the material is too strong.	Decrease pressure to the bobbin stopper so that the bobbin rotates lightly. Grind the part where cord passes.
Weaken tape tension. Grind the part where tape passes.		
The material to be sewn is pulled by the needle.	The needle catches the material during frame feed since the needle front tip is not above the material upper face when the needle bar is at the upper dead point.	After making needle height higher by 2 to 3 positions, perform adjustment by lowering needle height gradually while performing test sewing.
Tape guide is kept raised and does not lower. (It is not returned to the fabric face by spring force.)	Bad tape guide or tape N-Pipe	Replace.
	Bad tape guide spring	Replace.
	Sewing thread is too loose and jammed between tape guide and tape N-Pipe.	Adjust needle height and tension of sewing thread.

1st Edition December, 2007

4th Edition September, 2021

■ **Manufactured by : TISM Co.,Ltd.**

Address : NO.1800, Ushiyama-cho, Kasugai, Aichi-pref., 486-0901, Japan

TEL : 81-568-33-1161 FAX : 81-568-33-1191

■ **Distributed by : Tajima Industries Ltd.**

Address : NO.1800, Ushiyama-cho, Kasugai, Aichi-pref., 486-0901, Japan

TEL : 81-568-37-1130 FAX : 81-568-37-1230

●**Copy, reprint, or reform of a part or whole of this manual without permission is prohibited.**