

# ***USER'S MANUAL***

---

## ***OPTION FOR TLMX, TCWM HEATER WIRE FEEDING DEVICE***



## Foreword

This user's manual describes about the correct using method and instructions for use of this product. Please use this machine after understanding the contents of the manual.

This manual may contain discrepancies in detailed specifications as compared with the actual production model. If you have any questions about this manual, consult your TAJIMA distributor.

We believe that "BASICS TAJIMA EMBROIDERY MACHINES" and "MACHINE SETUP INSTRUCTIONS" are useful to deepen your knowledge about this product. Please also read those booklets.

Regarding how to handle the products related, refer to the user's manual exclusive for them included in the manual CD.

**TISM Co.,Ltd.**

## Safety precautions

To prevent any harm or damage to the person who use this product or other person, we describe items that must be surely followed as below.



Indicates that there is a lot of danger of death or serious injuries [\*1] if handled by mistake.



Indicates that there is a likelihood of death or serious injuries [\*1] if handled by mistake.





Indicates a potentially hazardous situation which may result in minor or moderate injury [\*2] or property damage if handled by mistake.

\*1: A condition caused by electric shock, injury, fracture of a bone, etc., that leads to aftereffects, or an injury that necessitates hospitalization or visits to a hospital over a long period.

\*2: An injury that does not necessitate hospitalization or visit to a hospital over a long period.

: Prohibited items

: Items that may cause electric shock if not observed

: Items that must be followed carefully to ensure safe operation

1 Name of each part .....	1
2 Movement .....	1
2-1 Outline .....	1
2-2 Spool core .....	2
2-3 Feed roller .....	2
2-4 Spool guide .....	2
2-5 Stopper .....	2
3 Adjustment.....	3
3-1 Timer .....	3
3-2 Twist-eliminating unit .....	3
3-3 Reciprocator .....	4
3-4 Hopper .....	5
3-5 Sensor .....	5
3-6 Return-preventive lever .....	5
3-7 Thread guide .....	5
3-8 Tension disk .....	6
3-9 Teflon tube .....	6
4 How to pass heater wire .....	7
4-1 How to pass heater wire (Ring type) .....	7
4-2 How to pass heater wire (Tube type) .....	8
5 Electrical system diagram.....	8
6 Setup of Heater wire feeding device.....	9
6-1 Installation of Heater wire feeding device .....	9
6-2 Removing the covers .....	9
6-3 Connecting the connectors .....	10
6-4 Attaching the grounding harness .....	10
6-5 Attaching of covers .....	10

## Name of each part

### 1. Name of each part

Main sections are shown here. For details, refer to the parts list.

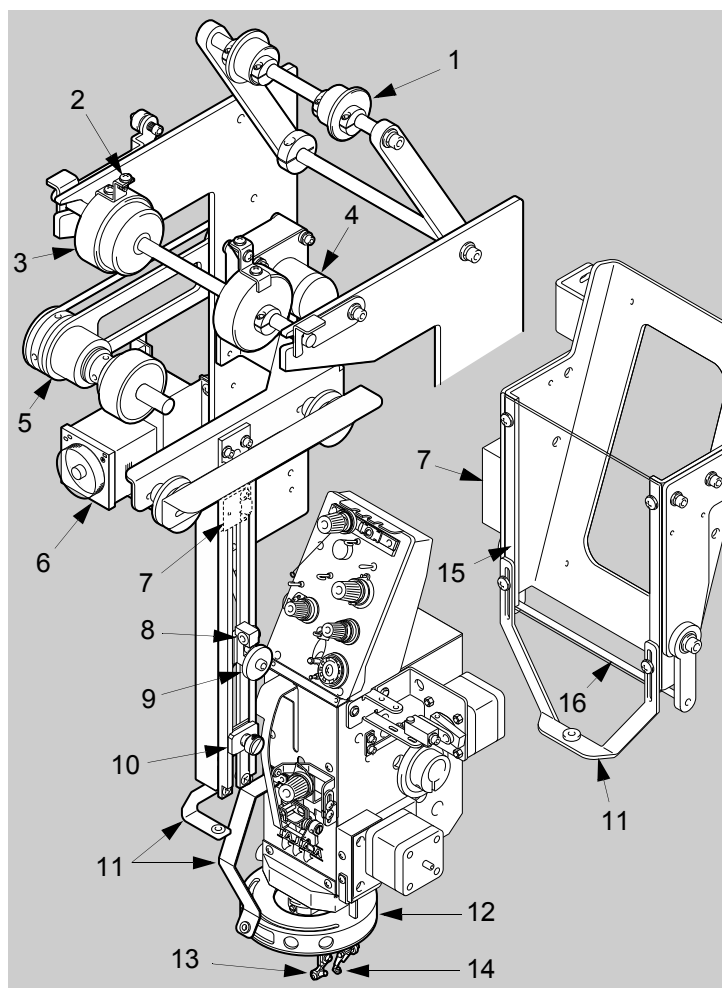

- (1) Spool guide
- (2) Conductive stay
- (3) Spool boss
- (4) Motor
- (5) Feed roller
- (6) Timer
- (7) Sensor
- (8) Reciprocator
- (9) Balancer
- (10) Stopper
- (11) Guide
- (12) Feed ring
- (13) Zigzag swing guide
- (14) Return-preventive lever
- (15) Hopper
- (16) Sensor arm

### 2. Movement

#### 2-1. Outline

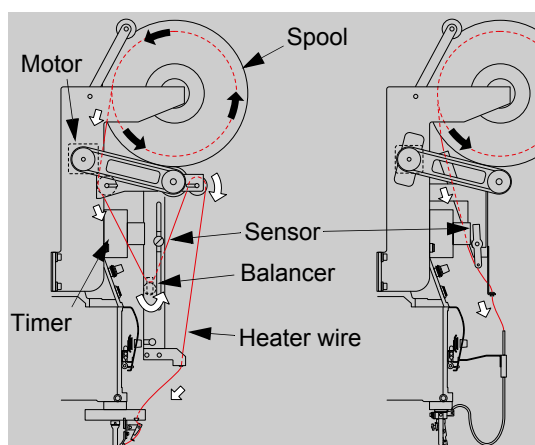

When the machine sews heater wire, the spool will feed adequate length of heater wire by the sensor detecting the tension of heater wire.

The heater wire passing method and the balancer are different depending on the thickness and material of heater wire.

## 2-2. Spool core

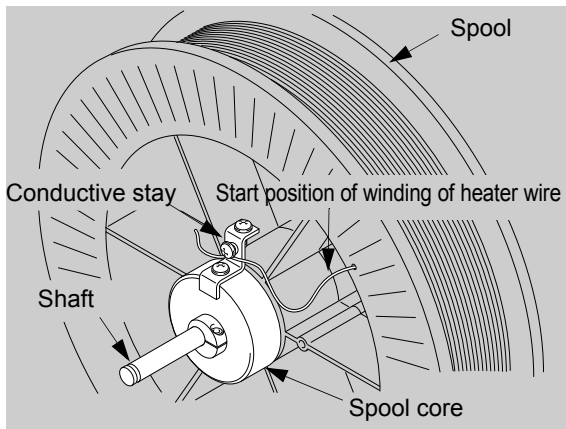

Put the shaft into the spool and install the spool in this device by fitting the spool core onto the shaft of the spool.

If the sizes of the spool core and the spool are mismatched, this will result in idle running of the spool. In order to operate the needle contact detecting device, connect the start position of winding of heater wire to the screw for the conductive stay, and tighten the screw.

## 2-3. Feed roller

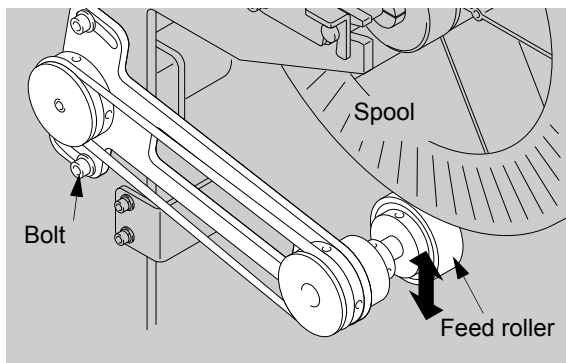

The roller will rotate the spool to feed the heater wire only in the time set by the timer. Tighten the bolt to adjust the position so that the feed roller can rotate in contact with the spool.

 If the contact of the feed roller with the spool is weak, it may cause mis-feeding.

## 2-4. Spool guide

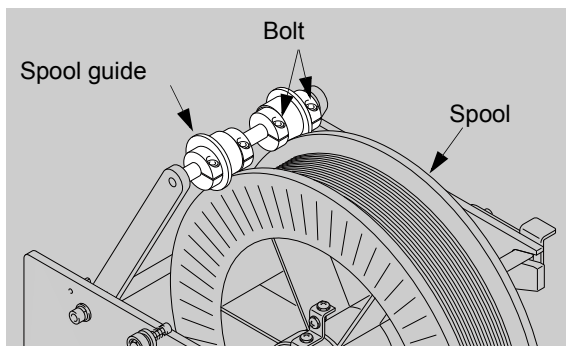

Spool guide is the part for preventing the heater wire from coming off the spool. Adjust the position so as to hold the spool from both sides by the spool guide. And tighten the bolts of the spool guide.

 If the spool rotates without setting (adjusting) the spool guide, it may cause the trouble that the heater wire becomes entangled with the other parts.

## 2-5. Stopper

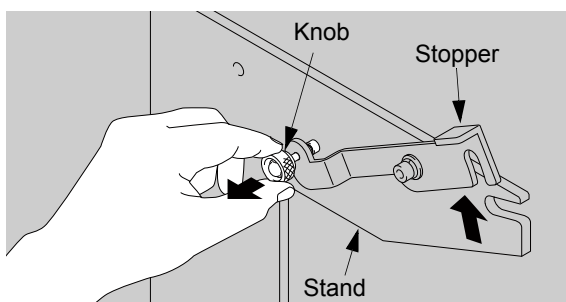

**(1)** Pull the knob of the stand to release the lock and open the stopper.

**(2)** After setting the spool on the stand, lower the stopper.

### 3. Adjustment

#### CAUTION

- ! Pay attention so that you do not forget to turn ON the switch when operating the machine.  
(ON :Lit, OFF :Unlit)
- If you start the embroidery machine while keeping the switch OFF, it may cause the damage to the embroidery machine and products because the timer does not operate and the embroidery is performed without the feeding of heater wire.

#### 3-1. Timer

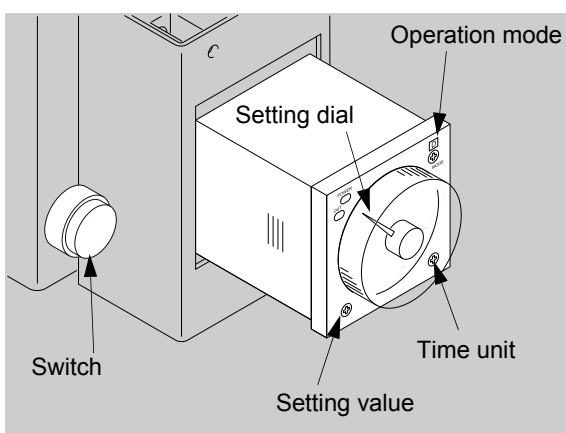

The switch will be lit when turning ON. Pressing the switch again will turn OFF (unlit).

According to the consumption of the heater wire, set the time by the setting dial.

The motor operates only in the time set by the timer to feed heater wire. As for the operation mode, use "D" and "E".

📖 Do not use "A", "B", "B2", "C" of the operation mode.

📖 Do not change the time unit and the setting value.

#### 3-2. Twist-eliminating unit

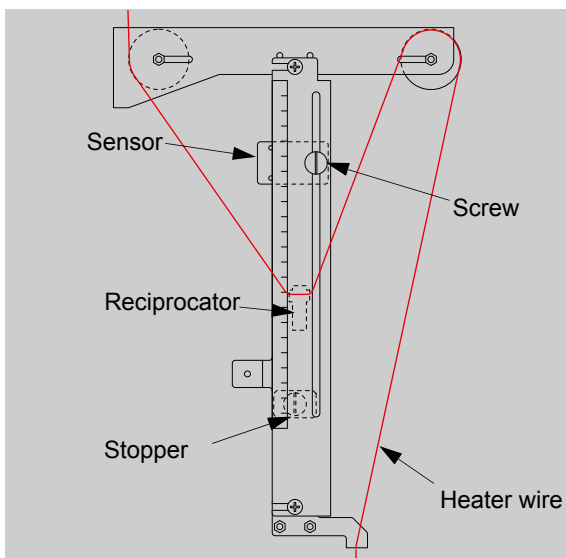

At the twist-eliminating unit, there is the sensor for detecting the feed amount of heater wire.

Adjust the position of the sensor and tighten the screw to fix the sensor.

Adjust the tension of heater wire by the balance between the consumption of heater wire during the movement of reciprocator from the stopper to the sensor and the feed amount set by the timer.

📖 Switch the position of the sensor and the operation mode of the timer depending on the method to use the twist-eliminating unit (Twist-eliminating mode / Loosening mode).

## Twist-eliminating mode

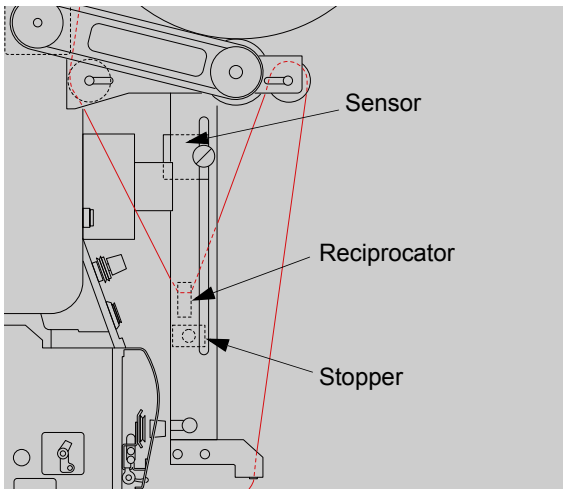

This mode is for feeding heater wire while applying constant tension to eliminate the twist of heater wire. It is suitable for thin heater wire.

Place the sensor at the upper side of the reciprocator, and use in the operation mode E.

📖 When the heater wire is consumed, the reciprocator will move up, and the sensor will become ON and the motor will rotate only in the time set by the timer and then stop.

## Loosening mode

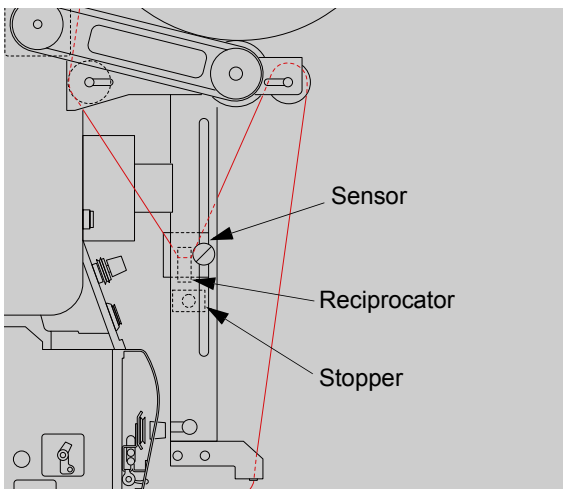

This mode is for feeding the heater wire while preventing deformation of heater wire without applying tension as much as possible. It is suitable for thick heater wire.

Adjust the stopper so that the reciprocator is stopped in the state that the sensor is ON, and use in the operation mode D.

📖 When the heater wire is consumed, the reciprocator will move up, and the sensor will become OFF and then the motor will rotate.

After that, the sensor will become ON, and the motor will rotate only in the time set by the timer and then stop.

## 3-3. Reciprocator

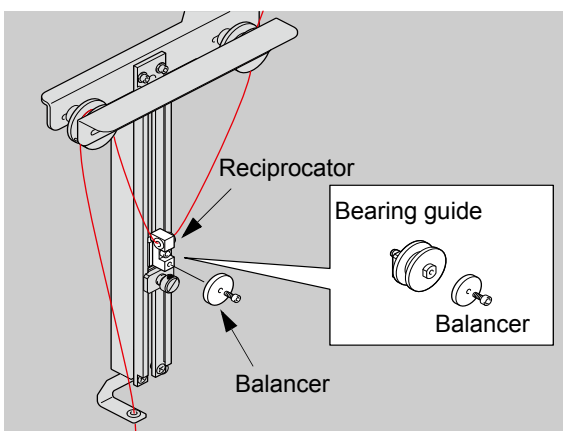

Thin heater wire : Pass it through the thread course of the reciprocator.

Thick heater wire : Pass it after replacing to the bearing guide from the reciprocator.

📖 Adjust the tension by the balancer in accordance with the material and thickness of heater wire.

Adjustment

3-4. Hopper

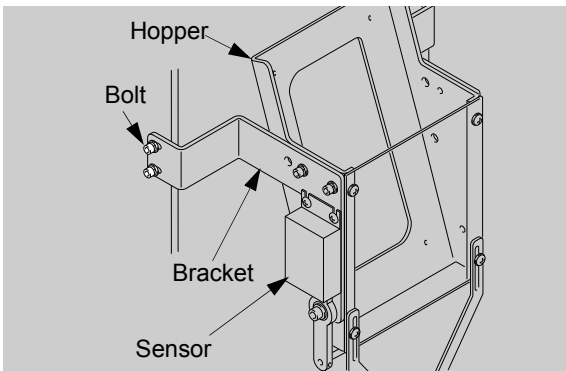

The sensor to sense the feeding of heater wire is attached to the hopper.

Adjust the bracket so that it is level and fix the bracket with bolts.

If the bracket is not level, the sensor cannot sense properly.

3-5. Sensor

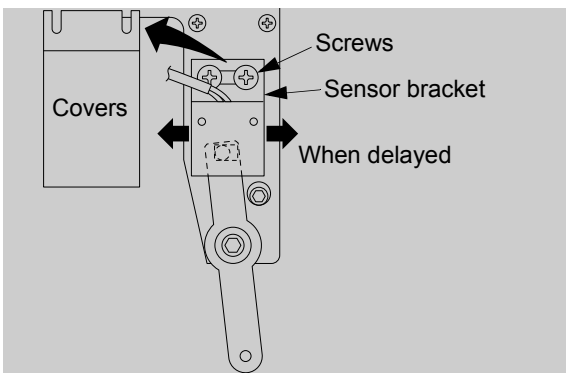

When the timing to send out the heater wire is delayed:

- (1) Loosen the screws of the cover to remove the cover.
- (2) Loosen the screws of the sensor bracket, move the position to the right and tighten the screws.

When the feed timing is early, move the position of the sensor bracket to the left.

- (3) Attach the cover after the adjustment.

3-6. Return-preventive lever

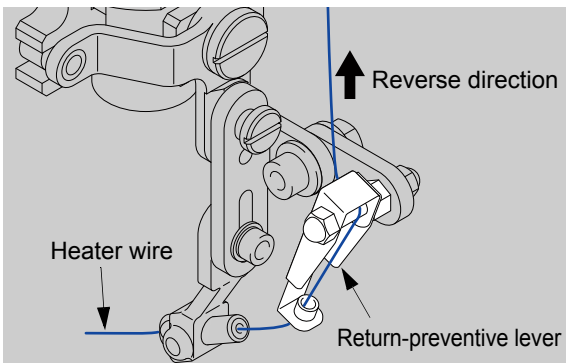

The heater wire may be pulled and returned to the reverse direction depending on the material of the heater wire if M-axis is rotated.

To prevent this returning movement, use the return-preventive lever.

3-7. Thread guide

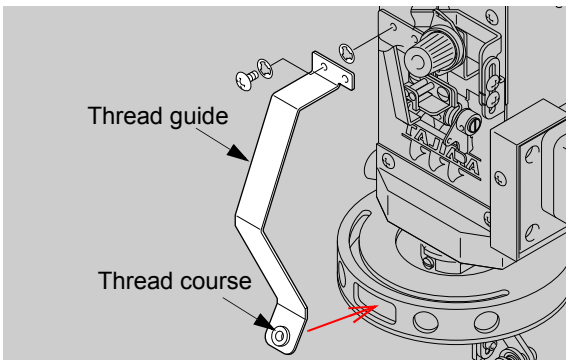

When sewing the thin heater wire, attach the thread guide.

Pass the heater wire through the window of the feed ring after passing the heater wire through the thread course.

### 3-8. Tension disk

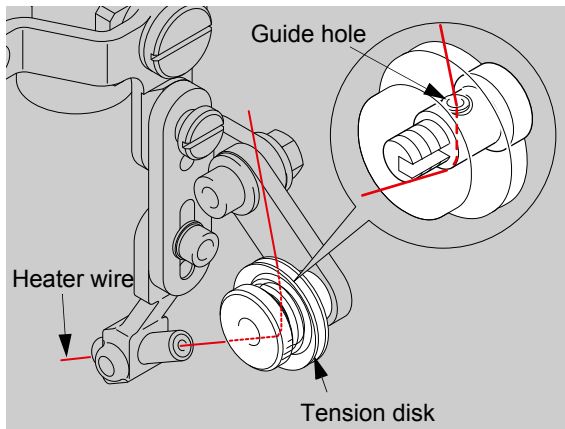

When passing thin heater wire, use the tension disk to eliminate the twist of the heater wire.

Pass the heater wire through the guide hole of the tension disk.

### 3-9. Teflon tube

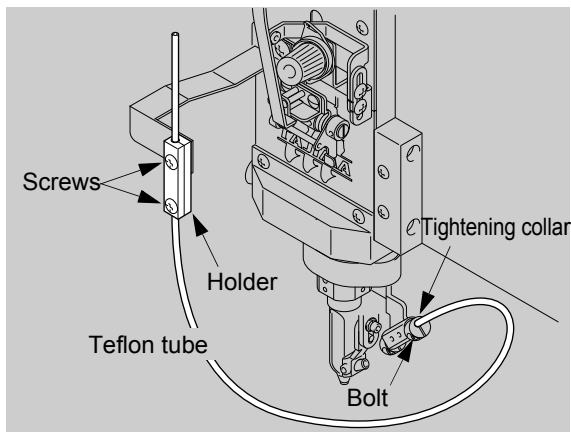

If the Teflon tube has deteriorated by abrasion or if the thickness of the heater wire is changed, please replace the Teflon tube.

**(1)** Loosen the screws of the holder, loosen the bolt of the tightening collar, and pull out the teflon tube.

**(2)** Replace to the new teflon tube, and fix it by tightening the screws of the holder and the bolts of the tightening collar.

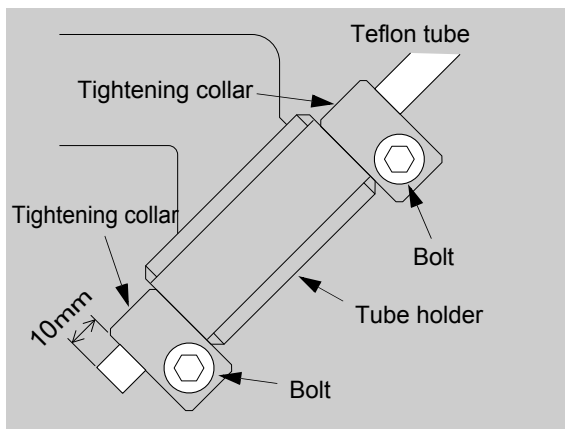

**(3)** Fix the bolts in the state that the end of teflon tube is protruded by 10mm.

📖 If the thickness of heater wire is changed, replace the teflon tube, holder, tightening collar and tube holder in accordance with the size of heater wire.

## 4. How to pass heater wire



### CAUTION

! When setting this device, be sure to turn OFF the switch and perform working.

#### 4-1. How to pass heater wire (Ring type)

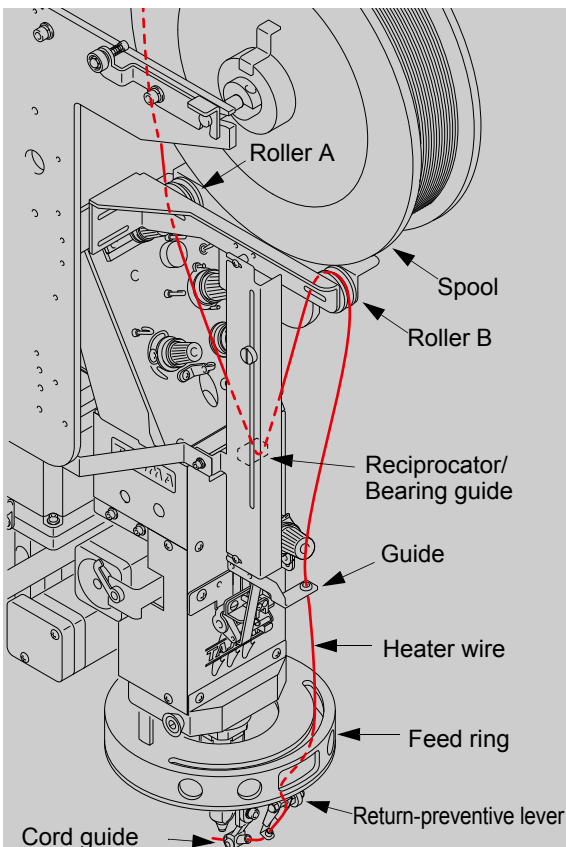

- (1) Pass the heater wire from the spool to the roller A.
- (2) Pass the heater wire from the reciprocator/bearing guide to the roller B.
- (3) Pass the heater wire from the guide to the feed ring.
- (4) Pass the heater wire into the thread course inside the feed ring.
- (5) Pass the heater wire through the return-preventive lever, and pull it out from the cord guide.

#### Feed ring

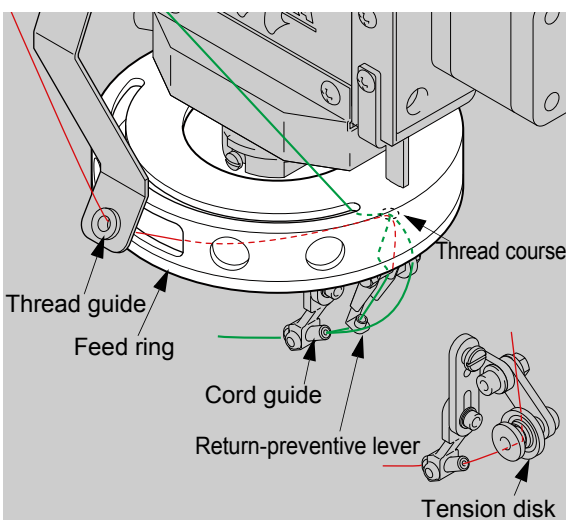

Use the return-preventive lever and tension disk properly in accordance with the material and thickness of heater wire.

- Normal or thick heater wire: —

Elongated hole on the top face of feeding ring →  
Thread course → (Return-preventive lever →) Cord guide

☞ If the heater wire is pulled and returned to the reverse direction, pass the heater wire through the return-preventive lever.

- Thin heater wire: —

Thread guide → Window of feed ring → Thread course  
→ Tension disk → Cord guide

#### 4-2. How to pass heater wire (Tube type)

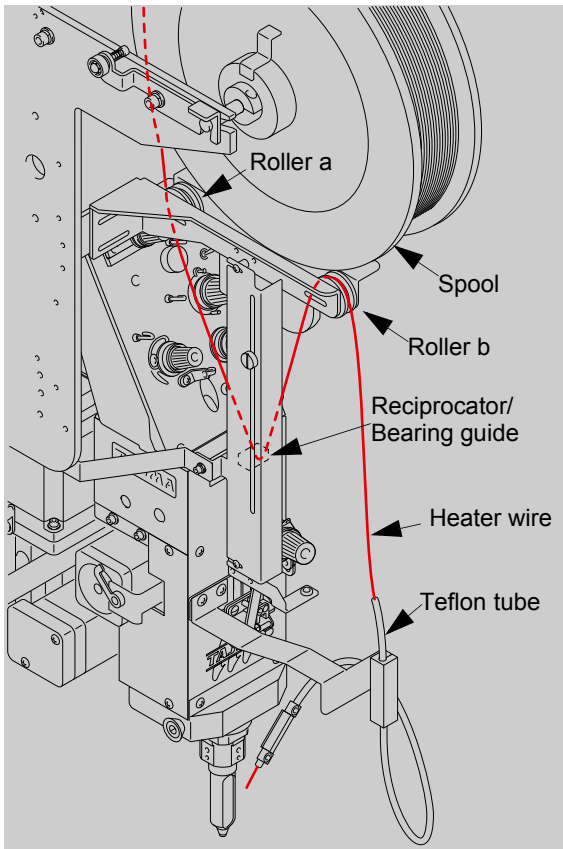

- (1) Pass the heater wire from the spool to the roller A.
- (2) Pass the heater wire from the reciprocator/bearing guide to the roller B.
- (3) Pass the heater wire into the teflon tube.

#### 5. Electrical system diagram

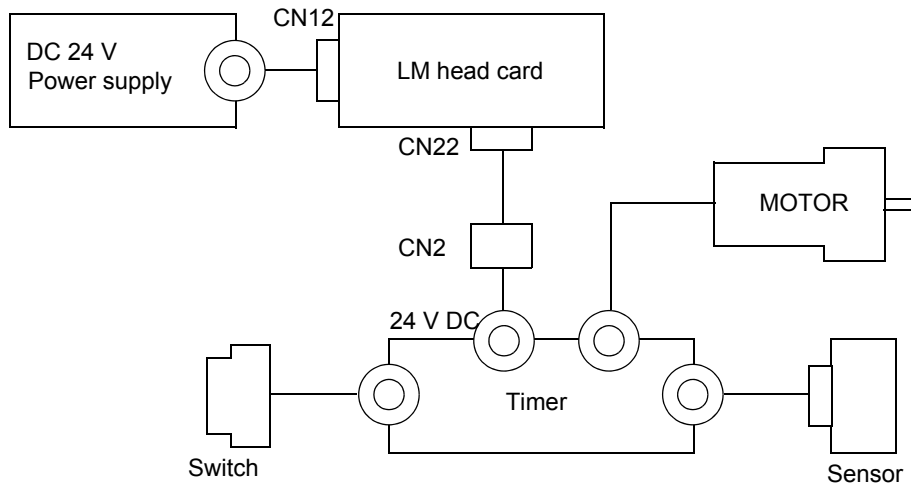

## 6. Setup of Heater wire feeding device

 This manual explains as an example about the case that the needle contact detecting device is mounted. If the needle contact detecting device is not mounted, it is not necessary to perform the work for the box (front).



### CAUTION

 When performing the setup, be sure to turn off the primary power supply (Before turning off the primary power supply, be sure to turn off the power switch). You could be injured by electric shock.

### 6-1. Installation of Heater wire feeding device

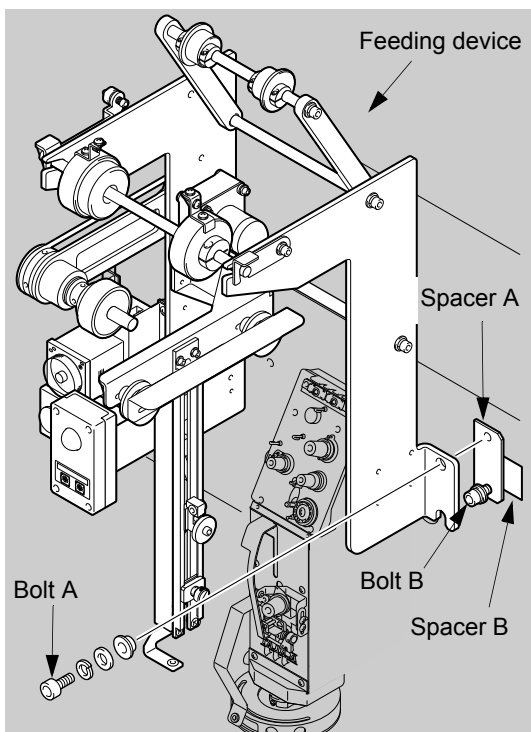

(1) Remove the bolt A which is temporarily fixed, and loosen the bolt B.

(2) Through the spacer A and B, fix the heater wire feeding device by the bolt A and B.

 There is a case that the spacer B is not contained.

### 6-2. Removing the covers

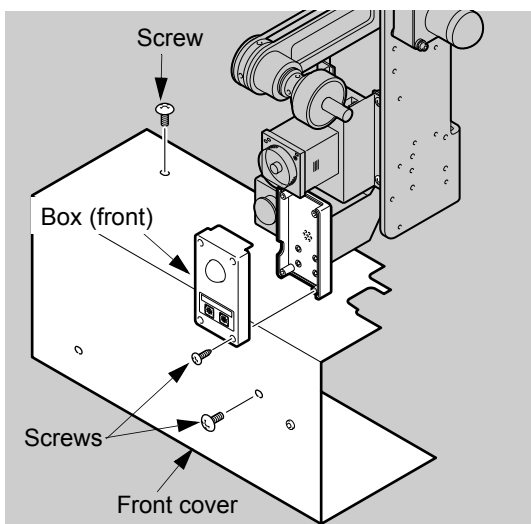

(1) Loosen the screws, and remove the front cover and box (front) along with the screws.

### 6-3. Connecting the connectors

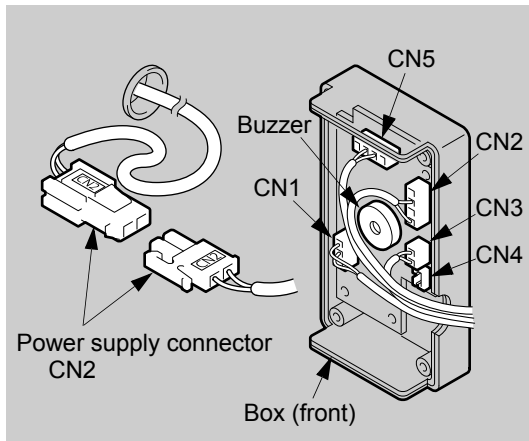

(1) Connect the power supply connector CN2, and connect the connectors CN1, CN2, CN3, CN5 of the box (front).

- ☞ Perform wiring so as not to block the buzzer.
- ☞ Connect the CN4 each other if there are multiple needle contact detecting devices.

### 6-4. Attaching the grounding harness

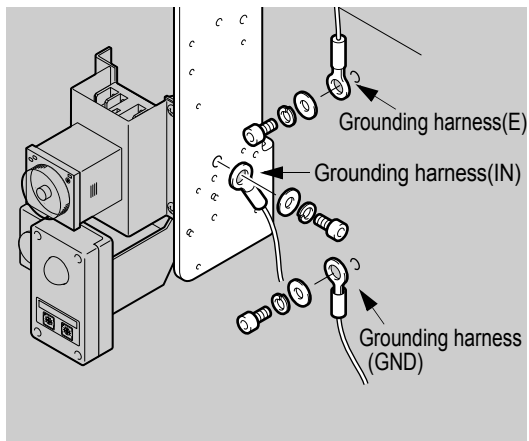

(1) Remove the bolt which is temporarily fixed.

(2) Fix the grounding harness (E, IN, GND) with bolts.

- ☞ The type of the grounding harness varies depending on the specification.

### 6-5. Attaching of covers

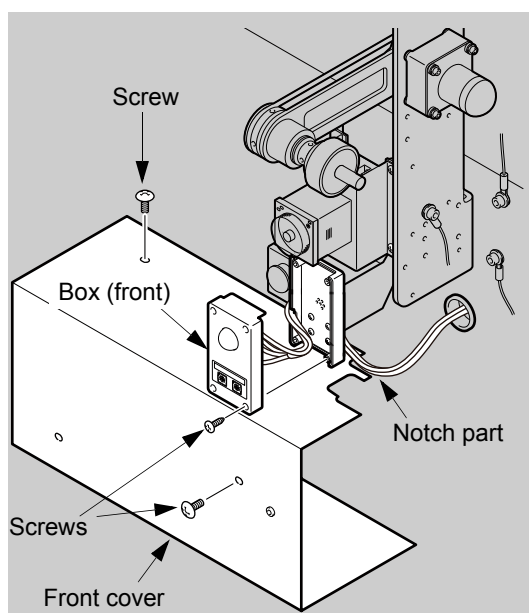

(1) Fix the front cover and box (front) with the screws.

- ☞ Pass the harness which comes out of the square pipe through the notch part of the front cover. the harness is in the state that it has been pulled out so as to connect the connector easily. Put the harness into the square pipe appropriately.

1st Edition      January, 2014

5th Edition      May, 2019

■ **Manufactured by : TISM Co.,Ltd.**

Address : NO.1800, Ushiyama-cho, Kasugai, Aichi-pref., 486-0901, Japan

TEL : 81-568-33-1161      FAX : 81-568-33-1191

■ **Distributed by : Tajima Industries Ltd.**

Address : NO.1800, Ushiyama-cho, Kasugai, Aichi-pref., 486-0901, Japan

TEL : 81-568-37-1130      FAX : 81-568-37-1230

●**Copy, reprint, or reform of a part or whole of this manual without permission is prohibited.**