

USER'S MANUAL

Operation instruction

BAR-CODE READER

HAR-VF

PAR-VF

PAX-VF



Foreword

This user's manual describes about the correct using method and instructions for use of this product. Please use this machine after understanding the contents of the manual.

This manual may contain discrepancies in detailed specifications as compared with the actual production model. If you have any questions about this manual, consult your TAJIMA distributor.

We believe that "BASICS TAJIMA EMBROIDERY MACHINES" and "MACHINE SETUP INSTRUCTIONS" are useful to deepen your knowledge about this product. Please also read those booklets.

Regarding how to handle the products related, refer to the user s manual exclusive for them included in the manual CD.

TISM Co.,Ltd.

SAFETY PRECAUTIONS

To prevent any harm or damage to the person who use this product or other person, we describe items that must be surely followed as below.



Indicates that there is a lot of danger of death or serious injuries [*1] if handled by mistake.



Indicates that there is a likelihood of death or serious injuries [*1] if handled by mistake.





Indicates a potentially hazardous situation which may result in minor or moderate injury [*2] or property damage if handled by mistake.

*1: A condition caused by electric shock, injury, fracture of a bone, etc., that leads to aftereffects, or an injury that necessitates hospitalization or visits to a hospital over a long period.

*2: An injury that does not necessitate hospitalization or visit to a hospital over a long period.

 : Prohibited items

 : Items that may cause electric shock if not observed

 : Items that must be followed carefully to ensure safe operation

1.	Preparation	1
1-1.	Available bar code specification	1
1-2.	Items to check.....	1
1-3.	To input design to machine.....	1
1-4.	To change memory design No.....	2
1-5.	To stick bar code on gauge frame	4
1-6.	Adjustment of bar cord reader	4
1-7.	To move frame automatically at start and end of sewing	8
2.	Sewing order	13
2-1.	To move gauge frame to reading position of bar code	13
2-2.	Start	14
3.	Troubleshooting	15
3-1.	When some error is displayed	15
3-2.	When bar code reader is broken	15
4.	Appendix	16
4-1.	Bar code reader	16
4-2.	Bar code sheet (for 4-digit)	17
4-3.	Bar code reader setting at shipment from factory	18

1. Preparation

Before sewing the design, the following checking and preparation are needed.

- 1-1. Available bar code specification
- 1-2. Items to check
- 1-3. To input design to machine
- 1-4. To change memory design No.
- 1-5. To stick bar code on gauge frame
- 1-6. Adjustment of bar cord reader
- 1-7. To move frame automatically at start and end of sewing

1-1. Available bar code specification

- (1) Bar code standard is adopted as "Code 39" that is common in industrial world.
- (2) Available bar code narrow-band width is 0.25 mm or more.
- (3) Make sure that there is no coating with irregular reflection or protective cover on the bar code.

1-2. Items to check

Check if the following parameter setting is "Stationary type". Input of the password in the middle of operation is necessary.

P7 - "77 Optional device (hardware)" - P2 - "16 Bar code reader"

1-3. To input design to machine

Input the design data of USB memory to the machine.

[How to operate]

(1) To set USB memory

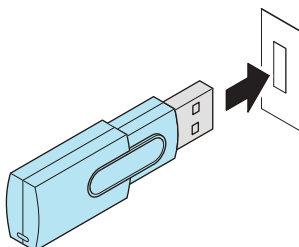

(2) Icon A

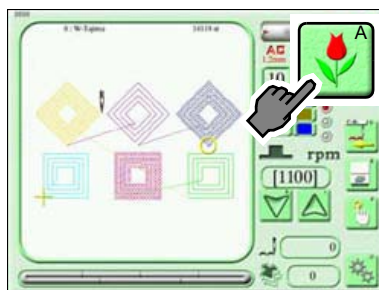

(3) Icon B

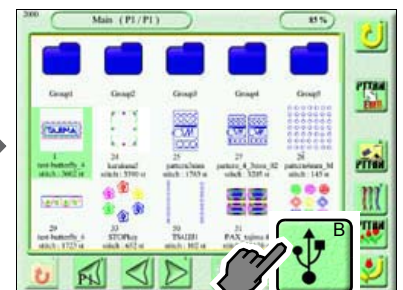

(4) Design

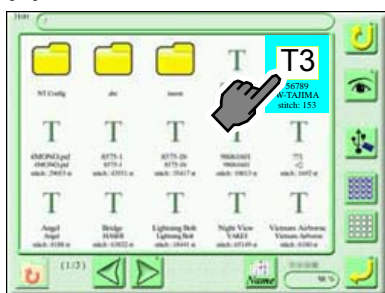

(5) To set

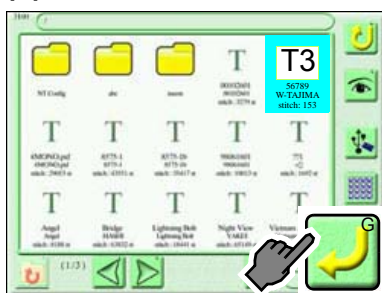

(6) Pattern-Main

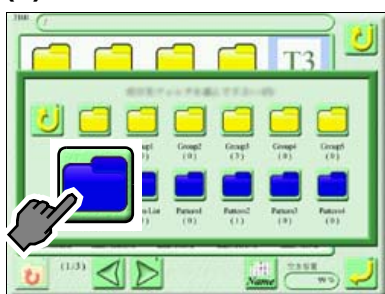

Select blue folder. The design will be saved as sewing mode.

(7) Screen 2000 (Completed)



1-4. To change memory design No.

Change the memory design No. of the design that is input to the machine. Select the memory design No. to fit the bar code No. according to your specification.

[When the bar code sheet is used]

Since bar code sheets are saved as data in accessory CD manual, print out and use them. (→p.17)

4-digit bar code

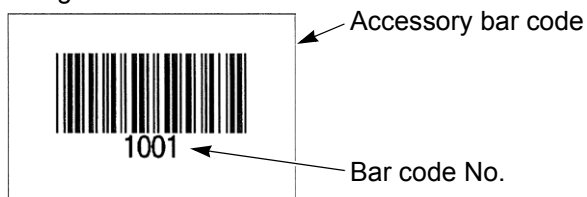

[When the bar code sheet is not used]

Create the bar code at your side, and select the memory design No. (from 0001 to 9500) to fit the bar code No. according to your specification.

[How to operate]

(1) Icon A

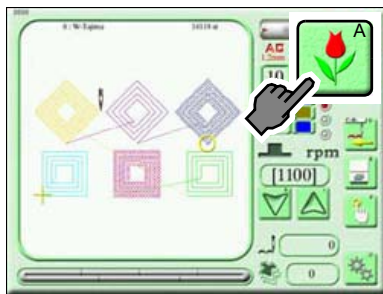

(2) Sewing design

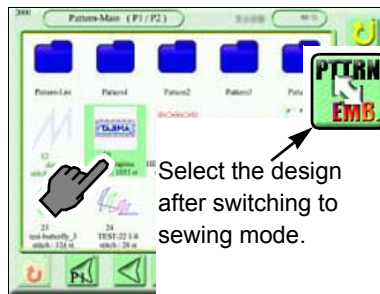

(3) Icon D

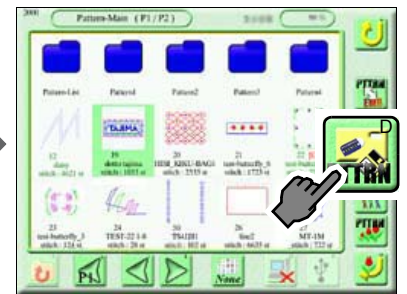

(4) To set

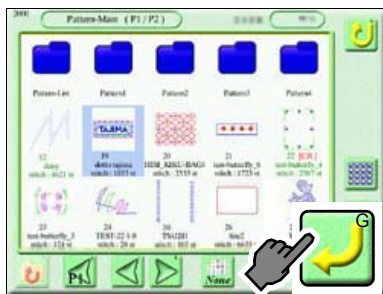

(5) Design creation



(6) To set

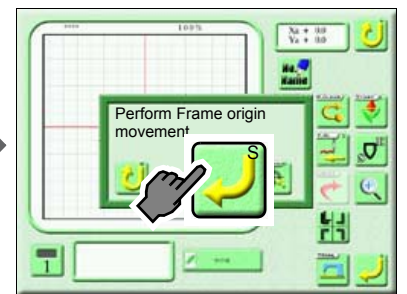

(7) Design No.

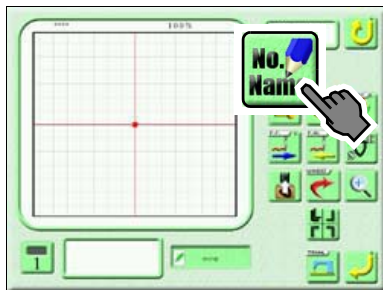

(8) Design No.



(9) Example: 1001^[1]

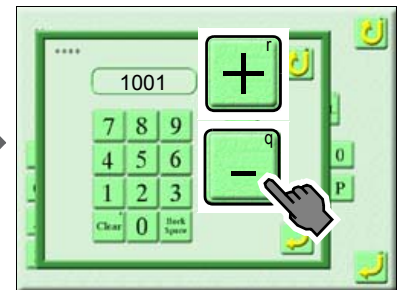

[1]When the design No. already registered is selected, it cannot be set.

(10)To set

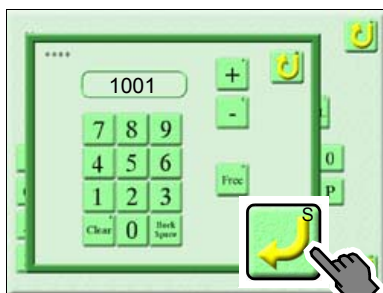

(11)To set (Completed)

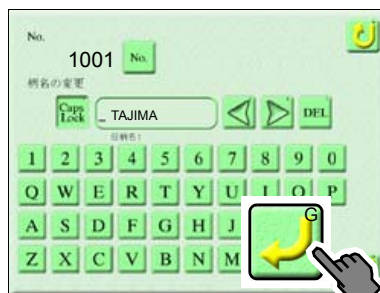

1-5. To stick bar code on gauge frame

Stick the bar code on the gauge frame.

When using bar code sheets, cut out the bar code of which No. is the same as the memory design No. from the bar code sheet, and stick it on the gauge frame.

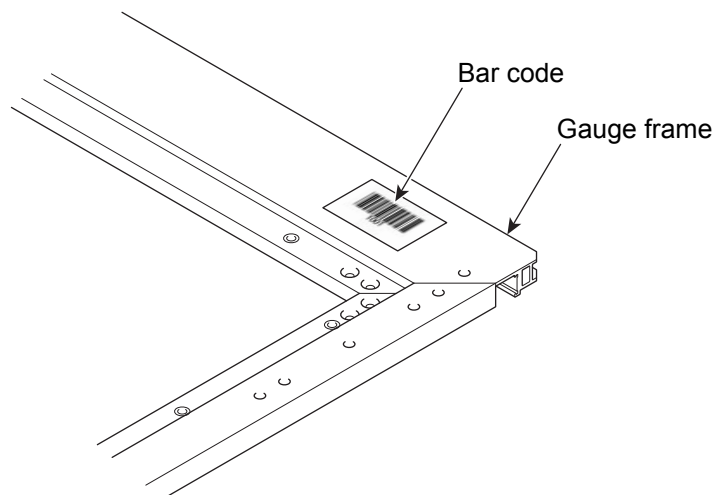

1-6. Adjustment of bar code reader

Move the frame to reading position of the bar code by the following operation on the operation panel.

CAUTION

 When performing this operation, do not put your hands, etc. on the table. Moving the frame could injure you.

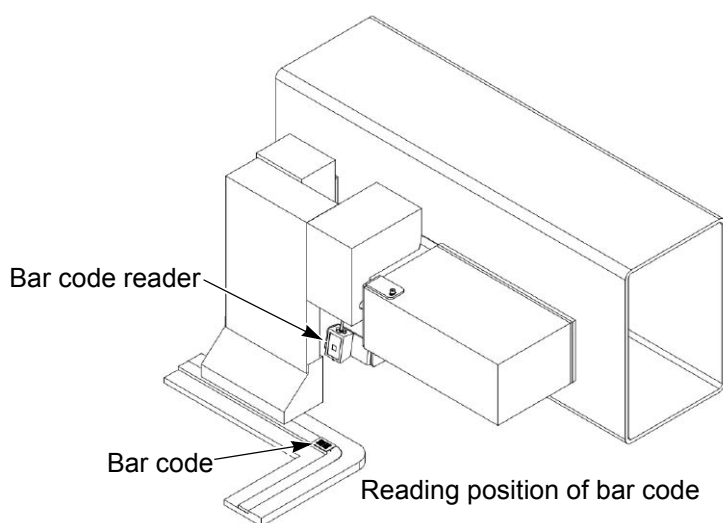

[How to operate]

(1) Icon G

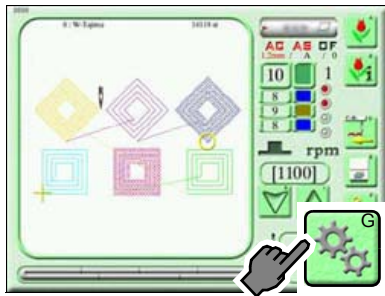

(2) Press P6 twice.

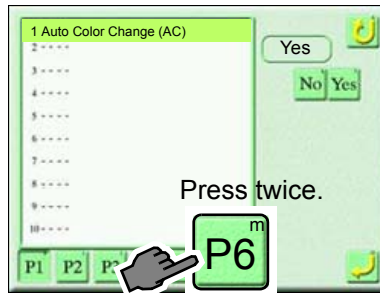

(3) Icon S

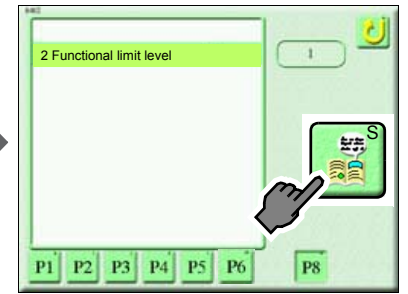

(4) Input a password.

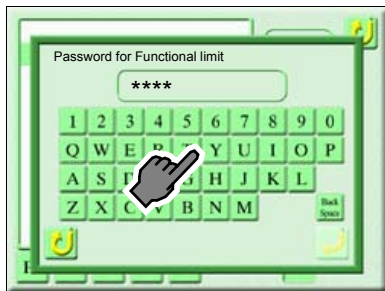

(5) To set



(6) SEL

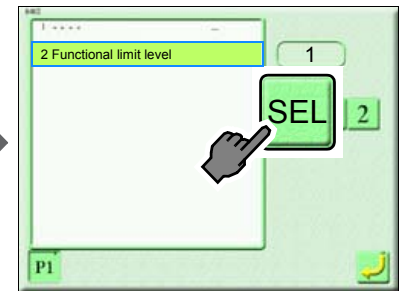

(7) Icon T

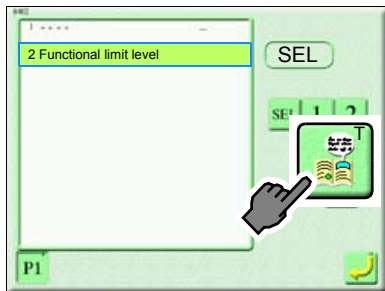

(8) ALL Yes

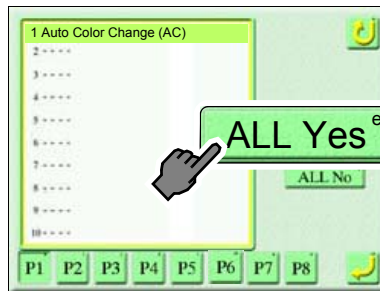

Outer frame turns yellow during setting level SEL.

Yellow



(9) To set

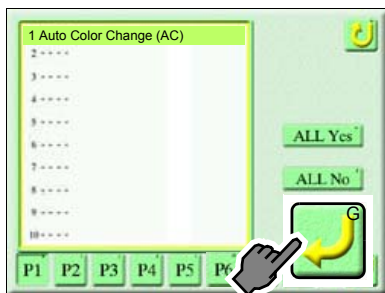

(10) To set

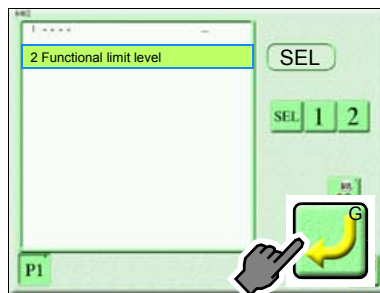

(11) Icon A

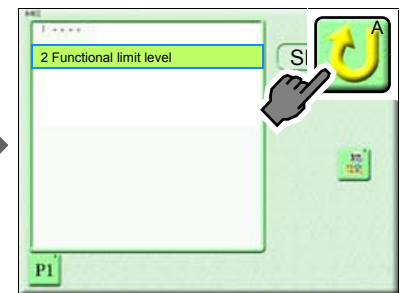

(12) 85 Machine adjustment

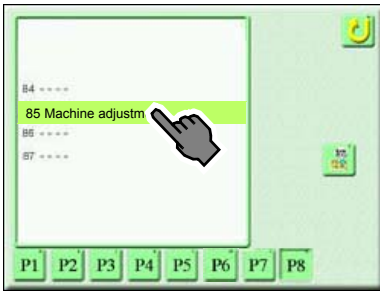

(13) Icon T

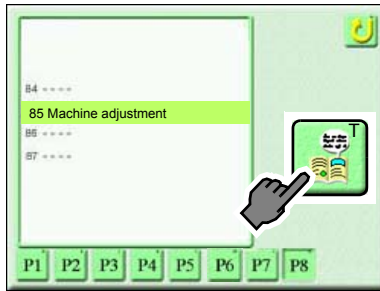

(14) P3

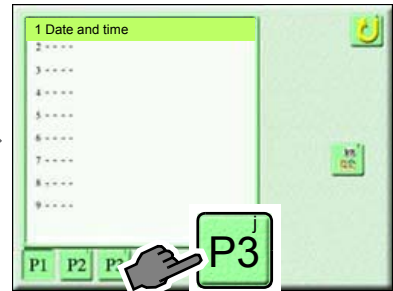

(15) 22 Adjustment of bar cord reader

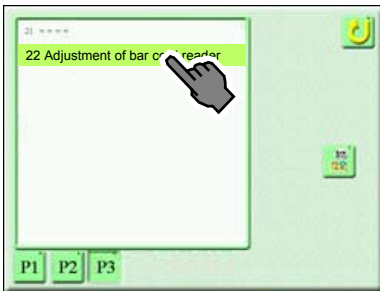

(16) Icon T

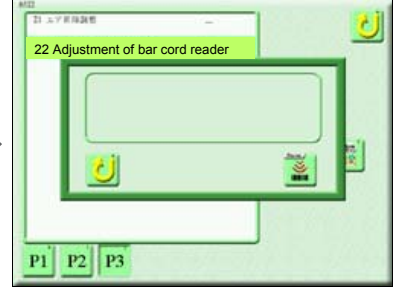
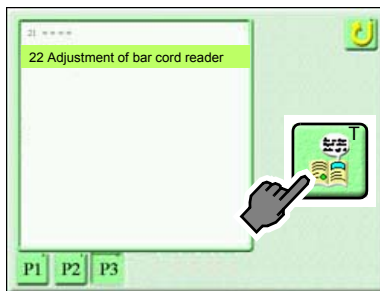

(17) Frame Travel



Move the frame to reading position of the bar code.

(18) READ

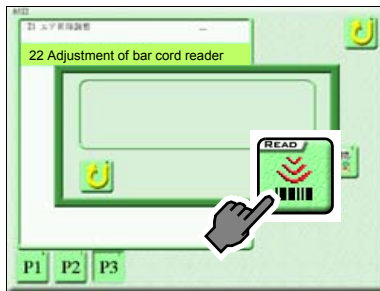

Bar code reading is successful.



If the bar code can be read, the bar code No. will be displayed as shown in the left figure.

If the bar code cannot be read, [RE] (Read Error) will be displayed. Move the frame again, and press the [READ] icon.

(19) Icon A

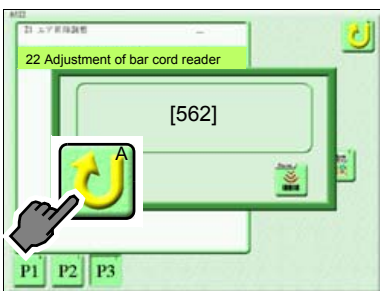

Perform setting of the next "39 Optional position" continuously. Reading position of the bar code will be registered by this setting.

(20)Icon A

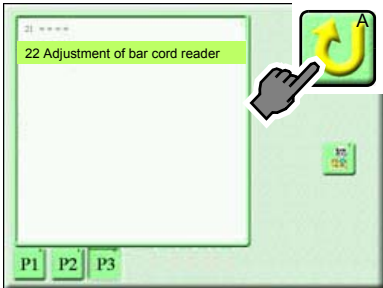

(21)P4

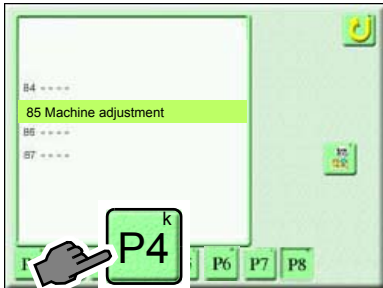

(22)39 Optional position

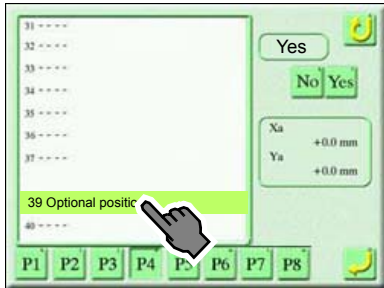

(23)Yes

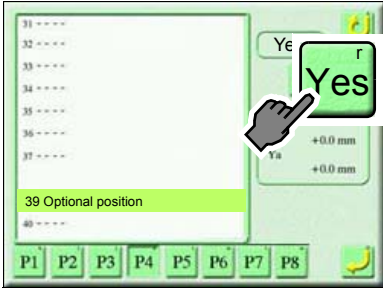

(24)To set (Completed)

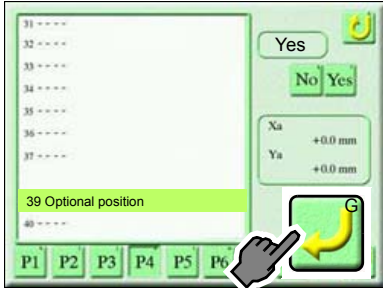

1-7. To move frame automatically at start and end of sewing

The start position and reading position of the bar code will be registered in the offset position by using this function (Automatic offset). As a result, the frame will move to the start position automatically at the start of sewing, and it will move to reading position of the bar code at the end of sewing. For details, refer to the user's manual of the machine.

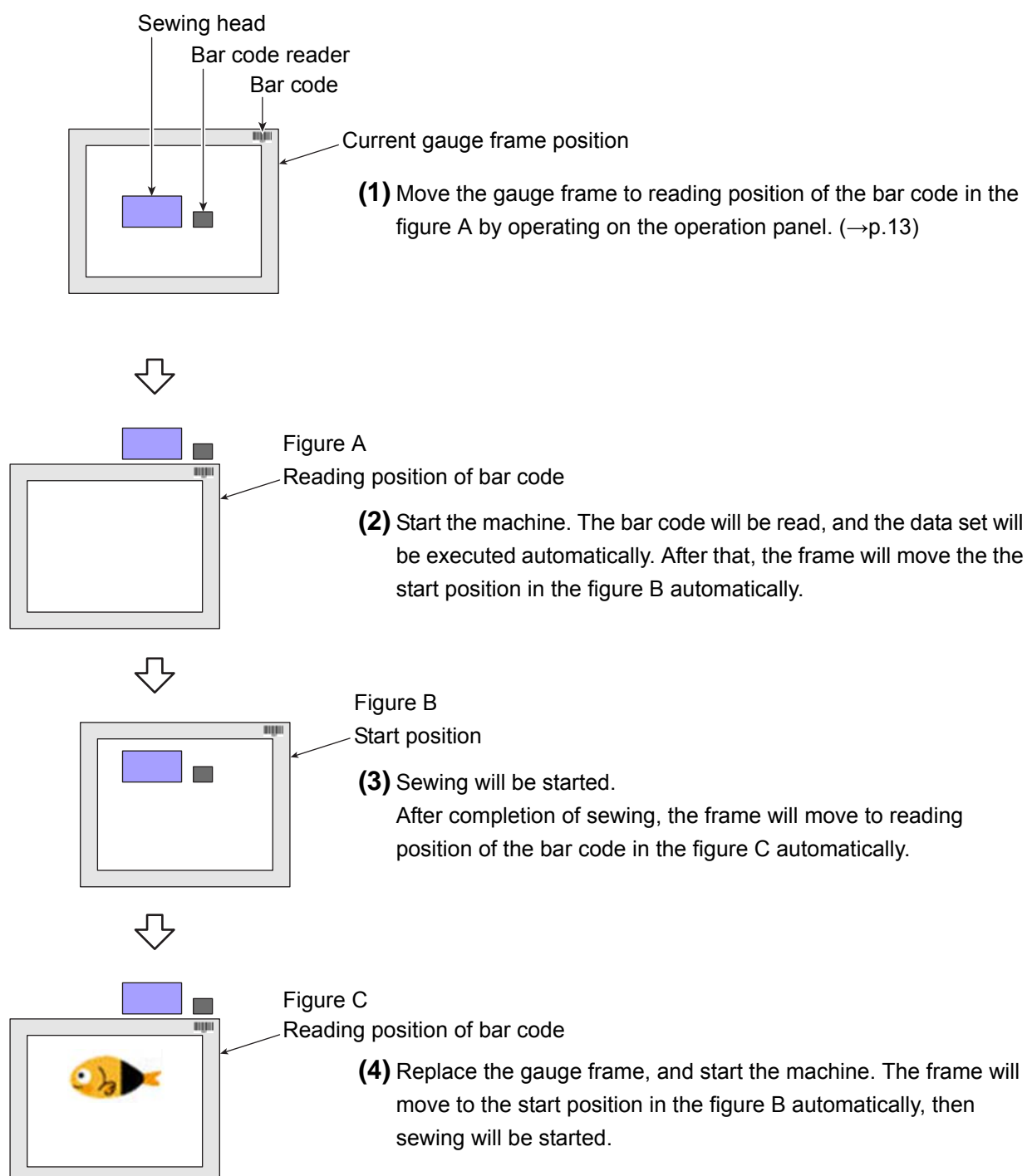

The frame can move through the middle position (OF1, OF2) up to 2 spots. Setting contents here will be added in the design. So, when embroidering this design next time, setting again will be unnecessary.

! CAUTION

⊘ When performing this operation, do not put your hands, etc. on the table. Moving the frame could injure you.

[An example of operation No.1]

The following is an operating example when "Start position" is included in the design.

This is the example that the frame moves without passing through the offset middle position (OF1, OF2) to the start position and the reading position of the bar code. The figure below shows the frame movement by using arrows when automatic offset is set.

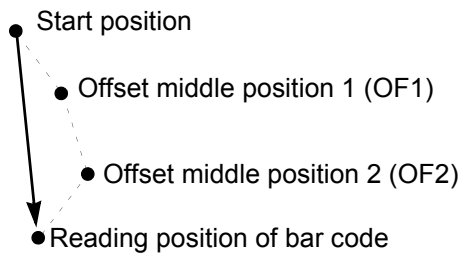

(1) Icon A

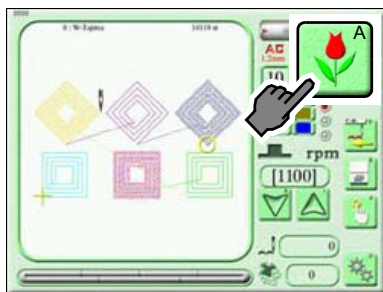

(2) Sewing design

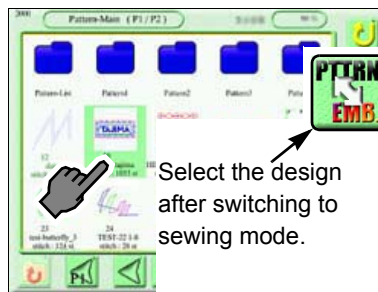

(3) PTTRN

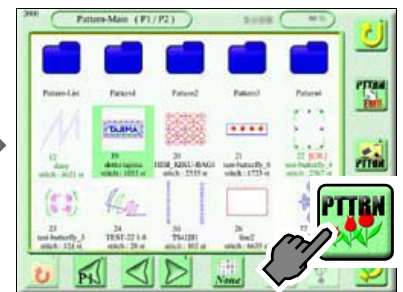

(4) OF

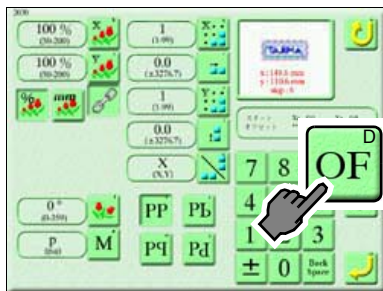

(5) Start position



(6) Yes

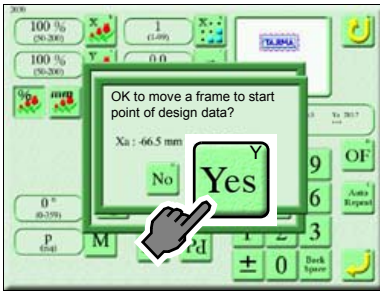

Pressing "Yes" will move the frame to "Start position" that is included in the design data.

(7) Reading position of bar code

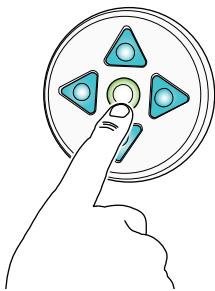

Move the frame to reading position of the bar code by pressing the frame travel key.

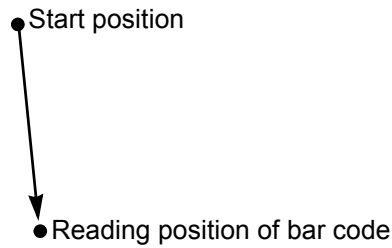

(8) OF1

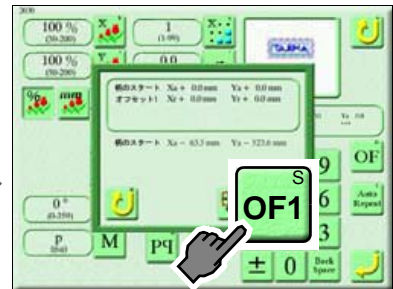

(9) OF2

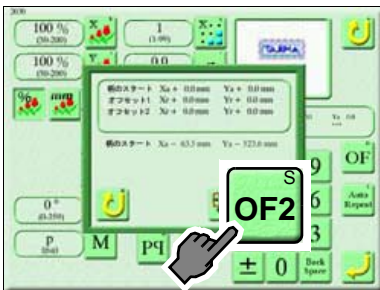

(10) To set (Completed)

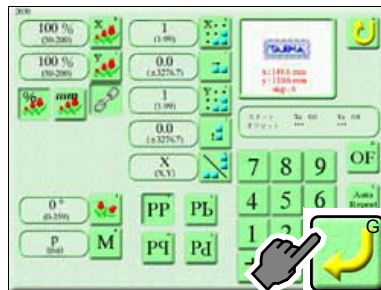

[An example of operation No.2]

The following is an operating example when "Start position" is included in the design.

This is the example that the frame moves through the offset middle position (OF1, OF2) to the start position and reading position of the bar code. The figure below shows the frame movement by using arrows when automatic offset is set.

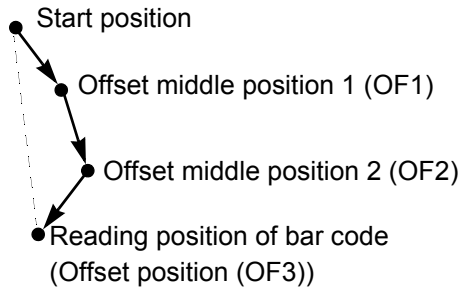

(1) Icon A

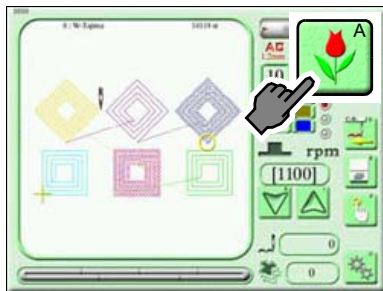

(2) Sewing design

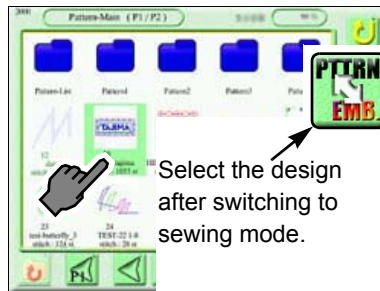

(3) PTTN

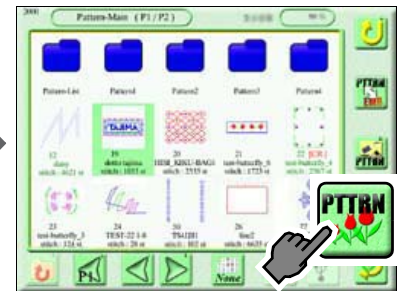

(4) OF

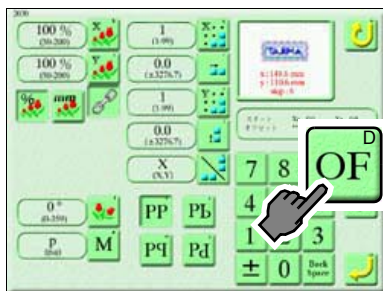

(5) Start position



(6) Yes

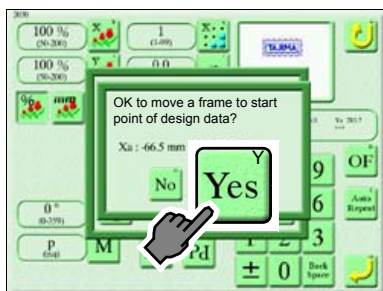

Pressing "Yes" will move the frame to "Start position" that is included in the design data.

(7) Offset middle position 1 (OP1)

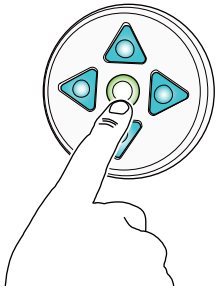

Move the frame to the offset middle position 1 by pressing the frame travel key.

- Start position
- Offset middle position 1 (OP1)

(8) OF1

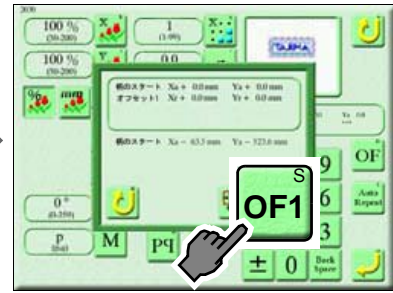

(9) Offset middle position 2 (OP2)

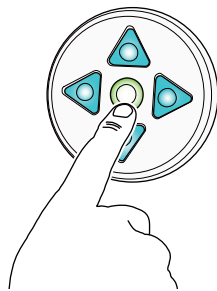

Move the frame to the offset middle position 2 by pressing the frame travel key.

- Start position
- Offset middle position 1 (OP1)
- Offset middle position 2 (OP2)

(10) OF2

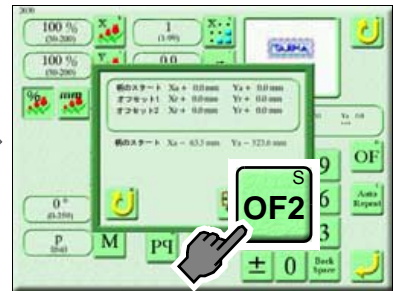

(11) Reading position of bar code

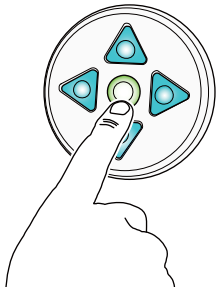

Move the frame to reading position of the bar code by pressing the frame travel key.

- Start position
- Offset middle position 1 (OP1)
- Offset middle position 2 (OP2)
- Reading position of bar code

(12) OF3

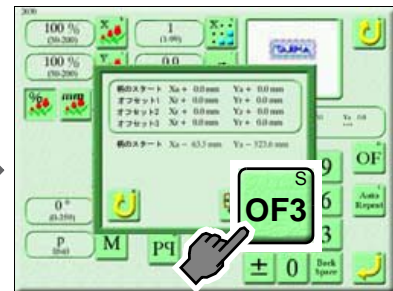

(13) To set (Completed)

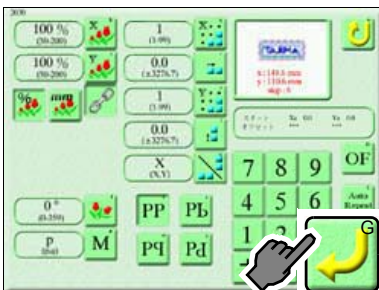

2. Sewing order

Before the start of sewing, check if the parameter setting is "Stationary type". (→p.1)

! CAUTION

! If the parameter setting is not "Stationary type", the needle could move down to the gauge frame resulting in damage of parts.

2-1. To move gauge frame to reading position of bar code

Perform this operation when the current frame position is not located at reading position of the bar code.

To move the gauge frame to reading position of the bar code, the following setting is necessary.

→1-6. Adjustment of bar cord reader (→p.4)

! CAUTION

! When performing this operation, do not put your hands, etc. on the table. Moving the frame could injure you.

[How to operate]

(1) Icon F

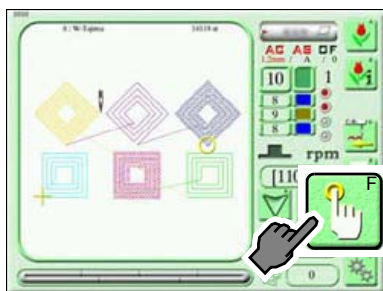

(2) Icon J

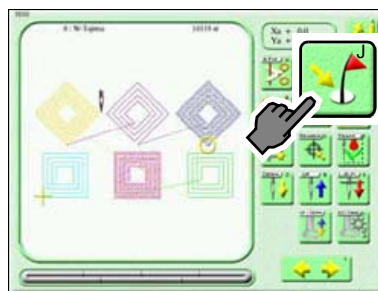

(3) Yes (Completed)

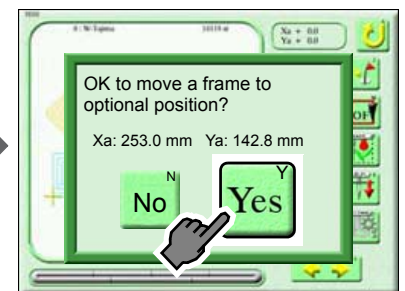

2-2. Start

- (1) Start the machine. The bar code will be read and the data set will be performed automatically by starting the machine. It will take several seconds from the start of the machine to the beginning of sewing. (It depends on the number of stitches of the design.)

However, in the middle of sewing, the bar code reader cannot read the bar code.

 **CAUTION**

 In the middle of sewing, the bar code reader cannot read the bar code. In the middle of sewing, even if the gauge frame is replaced during the stop of the machine and then the machine is started, the data set will not be executed and sewing will be continued. Therefore, the needle could move down to the frame.

To suspend sewing, follow the procedure below.

- a. Cancel the data set by operating on the operation panel.
- b. Move the gauge frame to "Reading position of the bar code" by operating on the operation panel. (→p.13)
- c. Start the machine. The bar code will be read, and sewing will start from the top of the design.

Bar switch

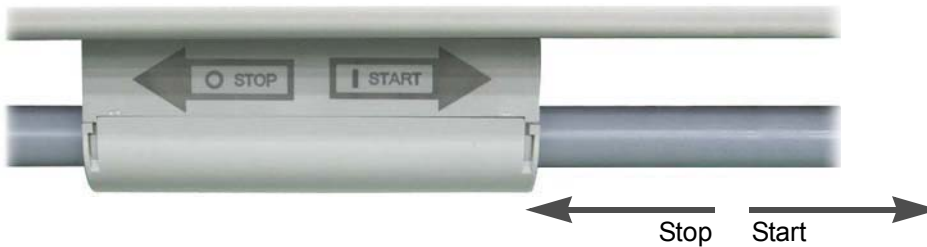

- (2) After completion of sewing, the frame will move to "Reading position of the bar code" automatically. If the machine is started after replacing the gauge frame at this position, the frame will move to "Start position", then sewing will be started. (→p.8)

3. Troubleshooting

3-1. When some error is displayed

(1) BC1

Content: Unregistered design error

Occurrence condition: When the design tried to input is not registered in the machine memory

Corrective action: Check "Memory design No.". Input the design data to the machine.

(2) BD1

Content: Bar code reading error

Occurrence condition: When the bar code reader cannot read the bar code

Corrective action: Change to stick the bar code and adjust the bar code position on the gauge frame.

3-2. When bar code reader is broken

When the bar code reader is broken, setting the parameter of the machine to OFF will cancel to link between the bar code and the design data. It is possible to sew the data set design by the bar switch starting.

P7 - "77 Optional device (hardware)" - P2 - "16 Bar code reader"

4. Appendix

4-1. Bar code reader















































Specifications

- (1) Stationary type
- (2) I/F: USB (COM)
- (3) Reading system: CMOS area sensor type
- (4) Operating temperature: -20 to 50°C
- (5) Operating humidity: 20 to 85% RH

4-2. Bar code sheet (for 4-digit)

Herewith, the bar code sheet (for 4-digit) is attached as a sample. Since bar code sheets are saved as data in accessory CD manual, print out and use them by cutting.

Memory Design No.1001 to 1050 / メモリ柄No.1001~1050
 If the margin on both sides of the bar code is small, it may cause a reading error.
 Please cut off the bar code along the lines and use.
 両サイドの余白が小さいと、読み取り不良の原因になります。切り取り線に沿って切り離してご使用下さい。

 1001	 1002	 1003	 1004	 1005
 1006	SAMPLE			 1010
 1011				 1012
 1016	 1017	 1018	 1019	 1020
 1021	 1022	 1023	 1024	 1025
 1026	 1027	 1028	 1029	 1030
 1031	 1032	 1033	 1034	 1035
 1036	 1037	 1038	 1039	 1040
 1041	 1042	 1043	 1044	 1045
 1046	 1047	 1048	 1049	 1050

TOKAI INDUSTRIAL SEWING MACHINE CO.,LTD.

1 / 60

4-3. Bar code reader setting at shipment from factory







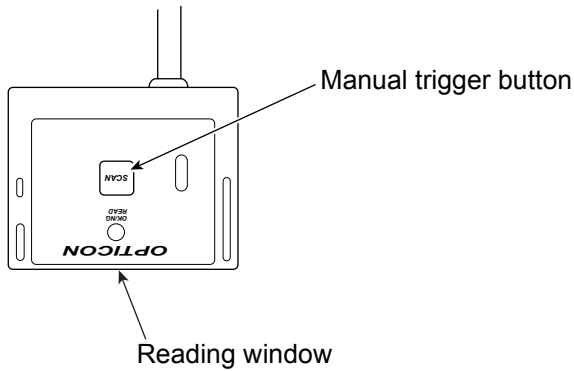



This is the setting for using 4-digit bar code as a memory design No. (Initialization)

It has been already set at shipment from factory.

When performing this setting, use the manual trigger button. If the manual trigger button is pressed, the reading line beam will be irradiated from the reading window. Perform scanning of bar codes in the list below in order.



Setting	Command	Bar code
(1) Start	ZZ	 Z Z
(2) USB-COM	C01	 C 0 1
(3) 1 second	Y1	 Y 1
(4) Buzzer volume: Small	T3	 T 3
(5) End	ZZ	 Z Z
(6) Start	ZZ	 Z Z
(7) Error message: Without label	TH	 T H

(8) R	0R	
(9) E	0E	
(10) ^M(CR)	1M	
(11) End	ZZ	
(12) Start	ZZ	
(13) Error message: Failure of decode	TI	
(14) R	0R	
(15) E	0E	
(16) ^M(CR)	1M	
(17) End	ZZ	

1st Edition May, 2019

4nd Edition May, 2019

■ **Manufactured by : TISM Co.,Ltd.**

Address : NO.1800, Ushiyama-cho, Kasugai, Aichi-pref., 486-0901, Japan

TEL : 81-568-33-1161 FAX : 81-568-33-1191

■ **Distributed by : Tajima Industries Ltd.**

Address : NO.1800, Ushiyama-cho, Kasugai, Aichi-pref., 486-0901, Japan

TEL : 81-568-37-1130 FAX : 81-568-37-1230

●**Copy, reprint, or reform of a part or whole of this manual without permission is prohibited.**