

USER'S MANUAL

Operation instruction

HAR-VF

1. Turn ON the power	82
2. Preparation	83
3. To input design to machine memory	91
4. To decide design to stitch (Data set)	97
5. To decide sewing mode	99
6. Items to check	101
7. To move frame to start position	103
8. Trace	104
9. To start sewing	106



Foreword

This user's manual describes about the correct using method and instructions for use of this product. Please use this machine after understanding the contents of the manual.

This manual may contain discrepancies in detailed specifications as compared with the actual production model. If you have any questions about this manual, consult your TAJIMA distributor.

We believe that "BASICS TAJIMA EMBROIDERY MACHINES" and "MACHINE SETUP INSTRUCTIONS" are useful to deepen your knowledge about this product. Please also read those booklets.

Regarding how to handle the products related, refer to the user's manual exclusive for them included in the manual CD.

TISM Co.,Ltd.

SAFETY PRECAUTIONS

To prevent any harm or damage to the person who use this product or other person, we describe items that must be surely followed as below.



Indicates that there is a lot of danger of death or serious injuries [*1] if handled by mistake.



Indicates that there is a likelihood of death or serious injuries [*1] if handled by mistake.





Indicates a potentially hazardous situation which may result in minor or moderate injury [*2] or property damage if handled by mistake.

*1: A condition caused by electric shock, injury, fracture of a bone, etc., that leads to aftereffects, or an injury that necessitates hospitalization or visits to a hospital over a long period.

*2: An injury that does not necessitate hospitalization or visit to a hospital over a long period.

 : Prohibited items



 : Items that may cause electric shock if not observed

 : Items that must be followed carefully to ensure safe operation

[Functional Limit Level]

Various types of machine operations are controlled by each functional limit level. This functional limit level will limit some operation and it has the purpose to protect designs from taking out unnecessarily or prevent incorrect parameter setting.

Functional Limit Level "1" is set at shipment. To change Functional Limit Level, input of the password is necessary. For details, consult the distributor.

Functional Limit Level	Limit contents
	<p>ALL Yes^e (Cancellation of Functional Limit Level)(→p.232)</p> <p>(1) All parameters will be displayed.</p> <p>(2) All parameters will be usable.</p>
<p> Setting at shipment</p>	<p>(1) Only items of parameter P1 to P5 will be displayed. However, "2 Functional Limit Level" of Page P8 will be displayed.</p> <p>(2) Writing the design data to the USB memory is prohibited.(→p.137)</p> <p>(3) Design data edit in the machine memory is prohibited. (→p.143 to p.146) Insertion of stitch, deletion of stitch, modification of stitch</p> <p>(4) Detailed setting (shown below) at step unit setting will be hidden.(→p.213) Satin Stitch (area), Satin Stitch (density), Satin Stitch (Expansion)</p>
<p> (→p.228)</p>	<p>(1) All parameters will be hidden. However, "2 Functional Limit Level" of Page P8 will be displayed.</p> <p>(2) Writing the design data to the USB memory is prohibited.(→p.137)</p> <p>(3) Design data edit in the machine memory is prohibited. (→p.143 to p.146) Insertion of stitch, deletion of stitch, modification of stitch</p> <p>(4) Detailed setting (shown below) at step unit setting will be hidden.(→p.213) Satin Stitch (area), Satin Stitch (density), Satin Stitch (Expansion)</p> <p>(5) Presser foot setting is protected.(→p.126)</p>

Chapter 1 Items that must be followed carefully

1.	To use this machine safely	2
1-1.	Warning	2
1-2.	Caution	3
2.	Important warning items for safe operation (UL-spec., CSA-spec.)	5
3.	Warning labels	8
4.	Inspection before starting work.....	10

Chapter 2 Name and way to use of each part

1.	Name of each part.....	12
2.	How to use each part.....	14
2-1.	Power supply switch	14
2-2.	Emergency stop switch	17
2-3.	Bar switch	19
2-4.	Operation panel	20
2-5.	USB port	21
2-6.	LAN port	22
2-7.	Tension base	23
2-8.	Presser foot	27
3.	Functions that must be used practically	29
3-1.	To perform return stitching at start of embroidery	29
3-2.	To lower/raise the presser foot.....	31
3-3.	To notify the operator that the position of the frame is misaligned	32

Chapter 3 Screen

1.	Basic screen	36
1-1.	Main screen (Screen 1010)	36
1-2.	USB memory screen (Screen 3100)	39
1-3.	Presser foot preset saving screen	41
1-4.	Data set screen	42
1-5.	Needle bar selection screen (Screen 2010)	43
2.	Sewing mode screen, Embroidery mode screen.....	44
2-1.	Sewing mode screen (Screen 2000)	46
2-2.	Embroidery mode screen (Screen 2000)	47
3.	Input operation	48
3-1.	To input value	48
3-2.	To input character	48

Chapter 4 Outline of functions

1.	Condition data.....	50
2.	Offset Frame Travel.....	52
2-1.	Automatic Offset	52
2-2.	Automatic Free-Setting Offset	53
2-3.	Auto Color Change Offset.....	54
3.	Trace.....	55
4.	Head selection	56
4-1.	Head selecting screen (Screen 2010)	56
4-2.	Pattern setting screen (Screen 2015).....	57
5.	Return Stitches, Tie Stitches	58
5-1.	V, Z, W.....	58
5-2.	Needle location offset screen	58
6.	Condensation sewing	59
6-1.	Condensation at start of sewing	59
6-2.	Condensation at end of sewing	60
7.	To create the design, to modify the design.....	61
7-1.	Design creation function list.....	61
7-2.	Design modification function list	74

Chapter 5 Sewing procedure

1.	Turn ON the power	82
2.	Preparation	83
2-1.	To set fabric.....	83
2-2.	To attach snarl-preventive parts	84
2-3.	To thread	88
3.	To input design to machine memory.....	91
3-1.	To input design in USB memory to machine memory	91
3-2.	To input design in personal computer to machine memory	93
3-3.	To input design in personal computer to machine memory (Using a bar code reader).....	95
4.	To decide design to stitch (Data set)	97
5.	To decide sewing mode.....	99
5-1.	To perform color change and start operation automatically.....	99
5-2.	To decide using order of needle bars	99

6.	Items to check	101
6-1.	To check size of design and setting contents	101
6-2.	To check sewing head	102
6-3.	To decide maximum speed	102
7.	To move frame to start position	103
8.	Trace	104
9.	To start sewing	106
9-1.	Countermeasure against thread breakage	107
9-2.	Completion of sewing	109

Chapter 6 Manual operation

1.	To return frame, to advance frame	112
1-1.	To switch Frame back, Frame forward	112
1-2.	To perform Frame Back, Frame Forward (Specification by number of stitches)	113
1-3.	To perform Frame Back, Frame Forward (Stop code)	114
2.	Thread trimming, color change	115
2-1.	To trim thread	115
2-2.	To change color	116
3.	Frame Travel	117
3-1.	To move frame to registered position (Frame travel to optional position)	117
3-2.	To return moved frame to previous position (Manual offset)	117
3-3.	To return frame to start position (Start position return)	118
3-4.	To move frame by inputting value (Input value for Frame Travel)	119
3-5.	To move frame to registered position (Offset return)	120
3-6.	To make machine memorize frame origin (Absolute origin search)	121
3-7.	Operation when power is shut off (Power resume)	122
4.	Raising and lowering of needle bar	123
4-1.	To lower needle bar	123
4-2.	To raise needle bar	123
4-3.	To lower needle bar to lower dead point	124
5.	Raising and lowering of presser foot	125
5-1.	To lower/raise the presser foot	125
5-2.	To set presser foot in unit of needle bar or step	126
6.	Others	129
6-1.	To turn ON/OFF the LED lamp	129
6-2.	Machine log data download	130

Chapter 7 Delete, save and edit of design

1.	To delete design	134
1-1.	To delete design in machine memory by one design unit.....	134
1-2.	To delete plural designs in machine memory	135
1-3.	To delete design in USB memory	136
2.	To save design, to change design name	137
2-1.	To write design into a USB memory (Input of a password is necessary)	137
2-2.	To change saving place of design	139
2-3.	To change design name	140
3.	To edit design	141
3-1.	To specify stitch No. to search stitch	141
3-2.	To specify function code and search stitch.....	142
3-3.	To insert a stitch (Input of the password is necessary).....	143
3-4.	To delete stitch (Input of the password is necessary).....	145
3-5.	To modify a stitch (Input of the password is necessary).....	146
3-6.	To delete minute stitch.....	147
3-7.	To set Arbitrary Block	149
3-8.	To make new start point (Jump Feed of Work Point)	154
3-9.	To move sewing position	156
4.	To copy, to divide and to combine design	158
4-1.	To copy design	158
4-2.	To divide design.....	159
4-3.	To combine design	160
4-4.	To sew sewing design and embroidery design in combination.....	164
4-5.	To change direction of sewing design and save it into machine memory.....	167
5.	To create sewing design.....	169
5-1.	Screen of Design Creation and Design Modification	169
5-2.	Scaling up/down of screen.....	171
5-3.	Setting screen of Design No.	172
5-4.	Sewing mode selection screen	173
5-5.	Selection screen of stitch length	173
5-6.	Machine Format setting screen	174
5-7.	To create sewing design.....	175
5-8.	To perform test sewing of sewing design	183
5-9.	To change start position of sewing design.....	185

Chapter 8 Convenient functions

1.	To move the frame to the position registered	188
1-1.	To move frame automatically at start and end of sewing (Automatic offset)	188
1-2.	To delete frame position registered (Automatic offset deletion)	190
1-3.	To move frame at position you desire during sewing (Automatic free setting offset)	191
1-4.	To move frame at color change position during sewing (Auto color change offset)	193
2.	To change size/direction of sewing design (Data Conversion)	194
2-1.	To scale up/down sewing design	194
2-2.	To rotate sewing design	195
2-3.	To reverse sewing design	196
3.	To repeat sewing design (Repeat)	197
3-1.	To repeat by specifying vertical or horizontal and number of times	197
3-2.	To arrange automatically	199
3-3.	To reverse alternately	200
4.	To change size/direction of embroidery design (Data Conversion)	202
4-1.	To scale up/down embroidery design	202
4-2.	To rotate embroidery design	203
4-3.	To reverse embroidery design	205
5.	To repeat embroidery design (Repeat)	206
5-1.	To repeat by specifying vertical or horizontal and number of times	206
5-2.	To arrange automatically	208
5-3.	To reverse alternately	209
6.	Advanced setting of the needle bar step	211
6-1.	To delete the needle bar selection setting	211
6-2.	To insert the new setting in the needle bar selection setting	212
6-3.	To sew only desired step by changing setting (Setting in unit of step)	212
6-4.	To replace specified needle bar No. with other needle bar No. in a batch (Needle bar conversion)	217
7.	Needle bar color	218
7-1.	To change the needle bar color	218

Chapter 9 Optional device

1.	Sequin Device.....	220
1-1.	To raise/lower all the Sequin devices of all heads at the same time	220
1-2.	To raise/lower Sequin devices individually	221
1-3.	To perform Color Change manually.....	222
1-4.	To replace Sequin 1 with Sequin 2 (Step unit)	222
1-5.	To replace Sequin 1 with Sequin 2 (Design data in a batch).....	224
2.	Automatic Lubrication System	225
2-1.	To operate Lubrication System.....	225

Chapter 10 Parameter (Setting item)

1.	Display setting of parameter	228
1-1.	You want to hide all parameters.	228
1-2.	You want to display the desired parameter only.....	229
1-3.	You want to hide the desired parameter only.	230
1-4.	You want to display all parameters.....	232
2.	Parameter	233
2-1.	Page P1	233
	1 Auto Color Change (AC).....	233
	2 Auto Start (AS)	233
	3 Auto start at same color.....	234
	4 Auto Start after auto data set.....	234
	5 Frame Type (Setting for border frame only)	235
	6 Total Stitch Counter	235
	7 Main Shaft Inching	235
	8 M.shaft Inching after ATH.....	236
	9 Auto jump	237
	10 Jump Convert	237
2-2.	Page P2	238
	11 F.B./F.F. Stitch unit.....	238
	12 Auto F.B. after T. detection.....	238
	13 Overlap Frame Back.....	239
	14 Halt before F.B./inching	239
	15 R.P.M. limit by needle position	240
	16 Presser foot lower dead point.....	240
	17 Presser foot stroke.....	241
	18 Presser foot timing.....	241
	19 Presser foot stroke mode.....	242

	20 Presser foot F.B. lower dead point.....	242
2-3.	Page P3.....	243
	21 Thread trim length	243
	22 Picker movement at start of emb.....	244
	23 Return Stitches/Condensation.....	245
	24 Tie Stitches/Condensation	247
	25 Upper thread lock timing	249
	26 Upper thread detection.....	250
	27 Under thread detection.....	250
	28 Upper thread binding at start of emb.....	251
	29 Auto origin return.....	252
	30 Return the frame after manual frame travel	252
2-4.	Page P4.....	253
	31 Jump Code Combine.....	253
	32 Language	253
	33 Preset Halt by stitches.....	254
	34 Preset Halt by Data	254
	35 Preset Halt by Designs.....	254
	36 Preset Halt by Lubrication	255
	37 Preset halt (1st before end code).....	255
	38 Table offset position	255
	39 Arbitrary position	256
	40 Needle Bar Color.....	256
2-5.	Page P5.....	257
	41 Lubrication cycle.....	257
	42 Lubrication cycle (head)	257
	43 Sequin device (R).....	258
	44 Sequin device (L)	259
	45 Auto lifting - Sequin device.....	260
	46 Boring step	261
	48 Multi Cord Setting.....	262
	50 Detailed Network information	262
2-6.	Page P6.....	263
	58 Detection of remaining Under thread (After Date Set , After ATH).....	263

2-7.	Page P7	264
	[71 R.P.M. setting]	265
	2 Low speed r.p.m. / Low speed code r.p.m. (Input of a password is necessary)	265
	3 Start/ATH inching r.p.m. (Input of a password is necessary)	266
	[72 Stitch Compensation].....	267
	1 Backlash (X) (Input of a password is necessary)	267
	2 Backlash (Y) (Input of a password is necessary)	267
	3 Satin Stitch (area) (Input of a password is necessary)	267
	4 Satin Stitch (density) (Input of a password is necessary).....	268
	5 Satin Stitch (Expansion) (Input of a password is necessary)	268
	[73 Design Setting]	268
	2 Condition data (Input of a password is necessary).....	268
	3 Automatic design rotation (180 deg.) (Input of a password is necessary).....	269
	[74 Frame Setting]	269
	3 Frame weight (Input of a password is necessary)	269
	4 Frame Travel Speed, Frame Stepping Method (Input of a password is necessary).....	270
	5 Frame start timing (Input of a password is necessary).....	271
	6 Absolute origin search at power ON.....	272
	8 Frame Travel Direction	272
	11 Origin correction amount (X).....	272
	12 Origin correction amount (Y).....	272
	[75 ATH Setting]	273
	1 ATH (Input of a password is necessary).....	273
	3 Sensitivity of ATH error detection (Input of a password is necessary)	274
	4 Under thread Release	275
	[76 Stop position].....	275
	1 Stop at Lower Dead Point (Input of a password is necessary).....	275
	2 Return Frame at Lower dead point (Input of a password is necessary)	275
	[77 Optional Device (Hardware)]	276
	1 Sequin device (R) (Input of a password is necessary)	276
	2 Sequin device (L) (Input of a password is necessary).....	276
	3 Insertion of jump at sequin (Input of a password is necessary).....	276
	4 Boring device (Input of a password is necessary)	277
	5 Cording Device (Input of a password is necessary)	277
	6 Multi Cord Device (Input of a password is necessary)	278
	8 Air Pressure Sensor (Input of a password is necessary).....	279
	9 Auto lubrication system (Input of a password is necessary).....	279
	11 Bobbin changer (Input of a password is necessary).....	279

12 LED Light (Input of a password is necessary).....	280
14 Sequential Control Device (Input of a password is necessary).....	280
16 Bar cord reader (Input of a password is necessary).....	280
[78 Optional device (Software)].....	281
1 Network (Input of a password is necessary)	281
2 Network name (Input of a password is necessary)	283
[79 Sequence control]	284
1. 5 V external input (Input of a password is necessary).....	284
2. 5 V external output (Input of a password is necessary)	284
4. 24 V external output (Input of a password is necessary)	284
2-8. Page P8.....	285
[84 Password (Functional limit)]	286
1 Password (Functional Limit) (Input of a password is necessary)	286
2 Functional Limit Level.....	287
[85 Machine adjustment]	288
1 Date and time (Input of a password is necessary)	288
2 Total number of thread breakage (Input of a password is necessary)	288
3 Error stack (Input of a password is necessary)	288
4 Memory process (Input of a password is necessary).....	289
5 Machine log data download (Input of a password is necessary).....	290
6 Display of main shaft stop position (Input of a password is necessary).....	291
7 Display of needle position angle (Input of a password is necessary).....	291
8 Time for detect power failure (Input of a password is necessary).....	292
9 Main Shaft Brake (Input of a password is necessary).....	292
12 Manual frame travel speed (Input of a password is necessary)	292
13 Automatic frame travel speed (Input of a password is necessary).....	293
15 Software install (Input of a password is necessary)	293
17 Sequin Chip Feed (Input of a password is necessary).....	294
17 Presser foot installation for Sequin (Sequin Chip Feed) (Input of a password is necessary)	295
18 Presser foot lower dead point adjustment (Input of a password is necessary)	296
19 Presser foot installation (Input of a password is necessary)	296
20 Needle bar upper dead point adjustment (Input of a password is necessary)	296
21 Air lifter adjustment (Input of a password is necessary).....	296
22 Bar cord reader adjustment.....	296

[86 Machine condition].....	297
1 Machine type, Machine number (Input of a password is necessary).....	297
2 X-axis embroidery space (Input of a password is necessary)	297
3 Y-axis frame size (Input of a password is necessary)	298
4 Frame spec. (Input of a password is necessary).....	298
5 Overlap (Input of a password is necessary)	298
6 Maximum RPM (Input of a password is necessary)	298
11 Frame weight level (Input of a password is necessary).....	299
12 Available head setting (Input of a password is necessary).....	299
13 X Stitch Length Adjustment (Input of a password is necessary).....	300
14 Y Stitch Length Adjustment (Input of a password is necessary).....	300
[87 Panel setting]	301
1 Sound volume (Input of a password is necessary).....	301

Chapter 11 Troubleshooting, maintenance

1. Troubleshooting	304
1-1. Stop factor (Code No.).....	304
1-2. When the machine does not sew well	312
2. Maintenance	313
2-1. Cleaning.....	314
2-2. Lubrication	317
2-3. Greasing	320
2-4. Inspection	322
2-5. Repair	322
3. Upgrading of software (Input of a password is necessary).....	323

Chapter 12 Appendix at the end of the manual

1. Specification of the machine	328
1-1. Ambient noise level.....	328
1-2. Power supply specifications.....	328
1-3. Machine weight.....	329
2. To use this machine as the embroidery machine	330
2-1. Recommended parts	330
2-2. Replacement of each part.....	331

Chapter 1













Items that must be followed carefully

1. To use this machine safely	2
2. Important warning items for safe operation (UL-spec., CSA-spec.) ...	5
3. Warning labels	8
4. Inspection before starting work.....	10

1. To use this machine safely



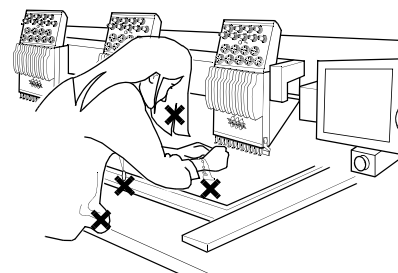
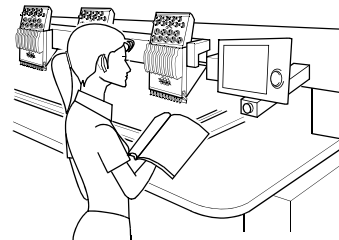
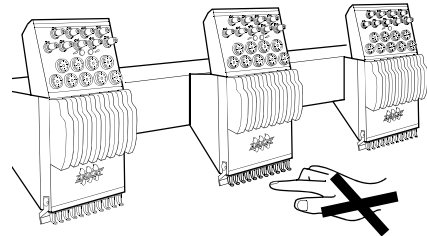

1-1. Warning

WARNING



-  This machine is designed for industrial use. Use this machine for semi- or finished textile products and similar materials. Using the machine for other purposes must be avoided.
-  Do not stand on the machine.
-  Do not use a device such as a cellular phone that generates microwave near the control circuits of the power supply box, the operation panel box, etc. Microwave may cause malfunctioning of the machine.
-  Do not detach covers for the shaft and the pulley. Also, do not run the machine without the covers.
-  Do not have your hands, etc. access to the vicinity of needle during operation. Otherwise, sticking of needle could injure you.
-  During operation, do not access your hands and/or face to moving sections. Especially, it is dangerous around needle, rotary hook, take-up lever, pulley and speed-reduction box.
-  Read this book thoroughly and understand the contents of operation certainly. Then, operate the machine.
-  Wear proper clothes and tidy up yourself so that you can smoothly perform the operation.
-  A single operator should operate the machine in principle. If plural operators are working together, make sure that no one is working near the moving units of the machine before starting the machine.
-  Use the machine under the environment where access can be supervised so that unauthorized person does not operate the machine. Supervise children so that they do not access to the machine.
-  Only the persons who are sufficiently trained for the operation must operate the machine.
-  The rear of the machine is not a working area. If you have to move to the rear of the machine, make sure to turn OFF the main switch.
-  When you perform threading or check finishing, be sure to stop the machine.



 **WARNING**

-  Do not damage, modify or heat the power or other cables. Do not exert undue force to them, either. Otherwise the cables will be damaged causing fire and electric shock.
-  Insert the power cable plug fully. If a metallic part etc. touches an electrode in the plug, it may cause fire and/or electric shock.
-  Keep away electrical units from water and chemicals. Entry or splashing of them into electrical units leads to short circuits, causing fire, electric shock and other troubles. If water or other chemicals enter the unit, turn OFF the power switch, shut OFF the primary power of the machine and contact your local distributor.
-  Before opening the electrical boxes, be sure to turn OFF the power switch of the machine and shut OFF the primary power. If not, it may cause electric shock.

1-2. Caution **CAUTION**

-  Use the machine with about 70% of the maximum speed as "Operation for total fitting" for about one week after installing this machine. By performing operation for total fitting, life of the machine will become longer, which will be useful to avoid unexpected troubles.
-  Do not use bent needles or needles that are not suitable for the material. Be sure to turn OFF the power switch after working, and turn OFF the primary power supply.
-  Do not put things on the machine table.

! CAUTION

! Control the operation noise in the environment.
 This machine is designed to reduce noise during operation. To improve the sound insulation performance in a factory still more, use the interior finish materials which show high sound insulating performance for the walls, ceiling, and floor of the factory.

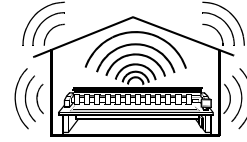

! Install the machine on a sturdy floor.
 The floor structure must be strong enough to bear the machine weight (indicated on the spec. plate).

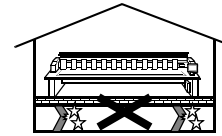

! Avoid dust and moisture.
 Since dust and moisture lead to dirt and rust on the machine, use the machine in an environment of facility of air conditioner, and clean the working place periodically. Use caution not to expose the machine to direct wind from the air conditioner so that sewing threads do not become disheveled.

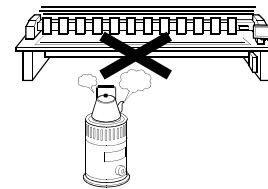

Humidity:
 30 to 95% RH (relative humidity) without condensation
 Ambient temperature:
 5 to 40°C (during operation), -10 to 60°C (during storage)

! Avoid direct sunlight.
 If the machine is exposed to direct sunlight over an extended period of time, the machine body may be discolored or deformed. Put curtains or shades to prevent the machine from direct sunlight.

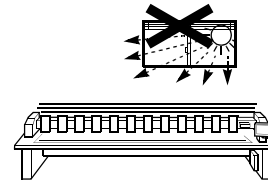

! Provide enough space for maintenance.
 Taking account of workability when maintaining and inspecting the machine, provide working area of 50 cm or more to right and left, and 55 cm or more to rear directions for the machine against obstacles such as walls.

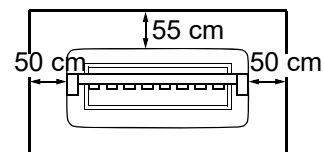

! Pay attention to interference of radio wave.
 Although the machine is designed not to affect radio wave interference to other equipments, there could be cases where it causes interference depending on operation environment and type of other equipment. If such problems arise, install the equipment with a space from the machine as big as possible.

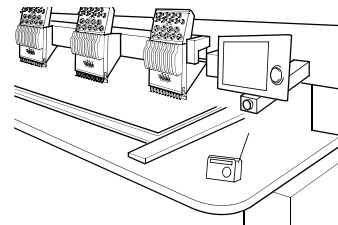

2. Important warning items for safe operation (UL-spec., CSA-spec.)

The following contents explains about UL, and CSA spec. machines.

IMPORTANT SAFETY INSTRUCTIONS

(applied to UL-spec. and CSA-spec. machines)

UL is safety standard applied to USA and CSA is safety standard applied to Canada.

Read all instructions before using this appliance.

When using an electrical appliance, basic safety precautions should always be followed, including the following:











DANGER

To reduce the risk of electric shock:







-  An appliance should never be left unattended when plugged in. Always unplug this appliance from the electric outlet immediately after using and before cleaning.

WARNING

To reduce the risk of burns, fire, electric shock, or injury to persons:

-  Do not allow to be used as a toy. Close attention is necessary when this appliance is used by or near children.
-  Use this appliance only for its intended use as described in this manual. Use only attachments recommended by the manufacturer as contained in this manual.
-  Never operate this appliance if it has a damaged cord or plug, if it is not working properly, if it has been dropped or damaged, or dropped into water. Please consult the nearest authorized dealer or service center and use this appliance after the examination, repair, electrical or mechanical adjustment has been made.
-  Never operate the appliance with any air openings blocked. Keep ventilation openings of the sewing machine free from the accumulation of lint, dust, and loose cloth.
-  Keep fingers away from all moving parts. Special care is required around the sewing machine needle.
-  Always use the proper needle plate. The wrong plate can cause the needle to break.
-  Do not use bent needles.
-  Do not pull or push fabric while stitching. It may deflect the needle causing it to break.
-  Switch the sewing machine off ("O") when making any adjustments in the needle area, such as threading needle, changing needle, threading bobbin, or changing presser foot, etc.
-  Always unplug sewing machine from the electrical outlet when removing covers, lubricating, or when making any other user servicing adjustments mentioned in the instruction manual.

WARNING

-  Never drop or insert any object into any opening.
-  Do not use outdoors.
-  Do not operate where aerosol (spray) products are being used or where oxygen is being administered.
-  To disconnect, turn all controls to the off("O") position, then remove plug from outlet.
-  Do not unplug by pulling on cord. To unplug, grasp the plug, not the cord.
-  Connect this appliance to a properly grounded outlet only. See Grounding Instructions.



SAVE THESE INSTRUCTIONS

GROUNDING INSTRUCTIONS

(applied to UL-spec. and CSA-spec. machines)

This product must be grounded. In the event of malfunction or breakdown, grounding provides a path of least resistance for electric current to reduce the risk of electric shock. This product is equipped with a cord having an equipment-grounding conductor and a grounding plug. The plug must be plugged into an appropriate outlet that is properly installed and grounded in accordance with all local codes and ordinances.

DANGER

-  Improper connection of the equipment-grounding conductor can result in a risk of electric shock. The conductor with insulation having an outer surface that is green with or without yellow stripes is the equipment-grounding conductor. If repair or replacement of the cord or plug is necessary, do not connect the equipment-grounding conductor to a live terminal.
-  Check with a qualified electrician or serviceman if the grounding instructions are not completely understood, or if in doubt as to whether the product is properly grounded.
-  Do not modify the plug provided with the product - if it will not fit the outlet, have a proper outlet installed by a qualified electrician.

! DANGER

! [If the product is used in a nominal rating up to 120V]

This product is for use on a nominal 120V circuit, and has a grounding plug that looks like the plug illustrated in sketch A in Figure-1. A temporary adaptor, which looks like the adaptor illustrated in sketches B and C, may be used to connect this plug to a 2-pole receptacle as shown in sketch B if a properly grounded outlet is not available. The temporary adaptor should be used only until a properly grounded outlet can be installed by a qualified electrician. The green colored rigid ear, lug, and the like, extending from the adaptor must be connected to a permanent ground such as a properly grounded outlet box cover. Whenever the adaptor is used, it must be held in place by the metal screw.

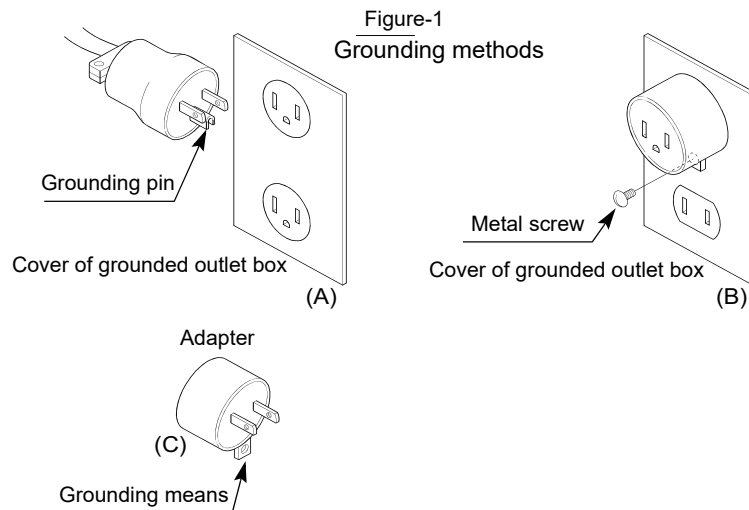

⊘ [If the product is used in a nominal rating more than 120V]

This product is for use on a circuit having a nominal rating more than 120V, and is factory equipped with a specific electric cord and plug. No adaptor should be used with this product. If the product must be reconnected for use on a different type of electric circuit, the reconnection should be made by qualified service personnel; and after the reconnection, the product should comply with all local codes and ordinances.

3. Warning labels

The machine has warning labels that bear instructions for safe operation. Machine operators must follow the instructions shown on the warning labels. Do not detach the warning label nor make them illegible by painting, etc. If the warning label is missed or damaged, contact your TAJIMA distributor.



[a] There could be danger of burn, death or severe injury due to electric shock. Persons except the service personnel designated by Tajima should not open the covers. When you open the cover, turn OFF the power switch and wait for four minutes or more.



[b] There could be danger of being caught.

Persons except the service personnel designated by Tajima should not open the covers.

[c] Pay attention not to be caught into the machine.

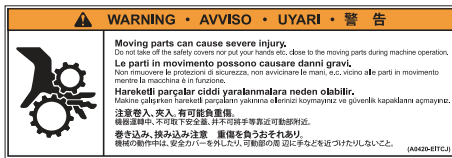

[e] Pay attention around needle.

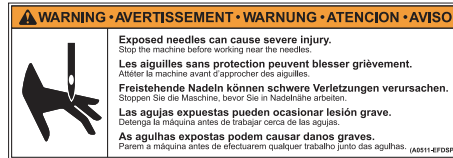

[d] Pay attention not to be clipped into the machine.

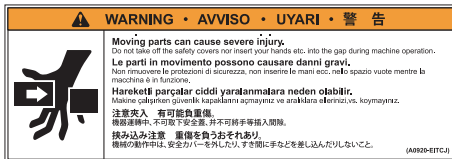

[f] Pay attention to rotary hook.



[Front view]

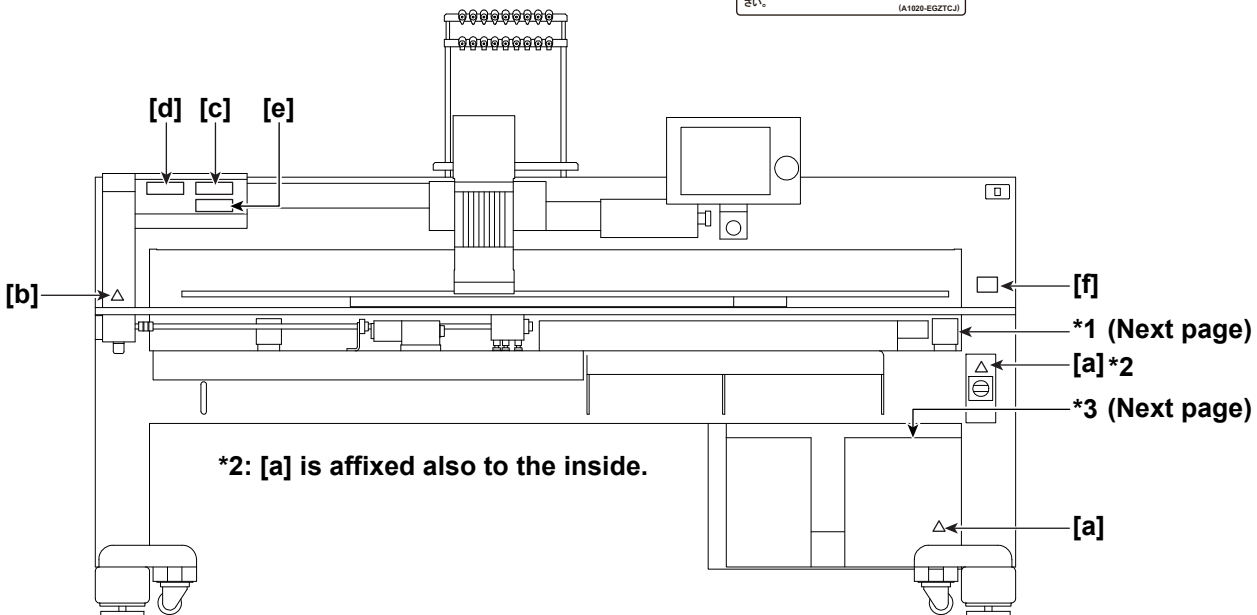

[Rear view]

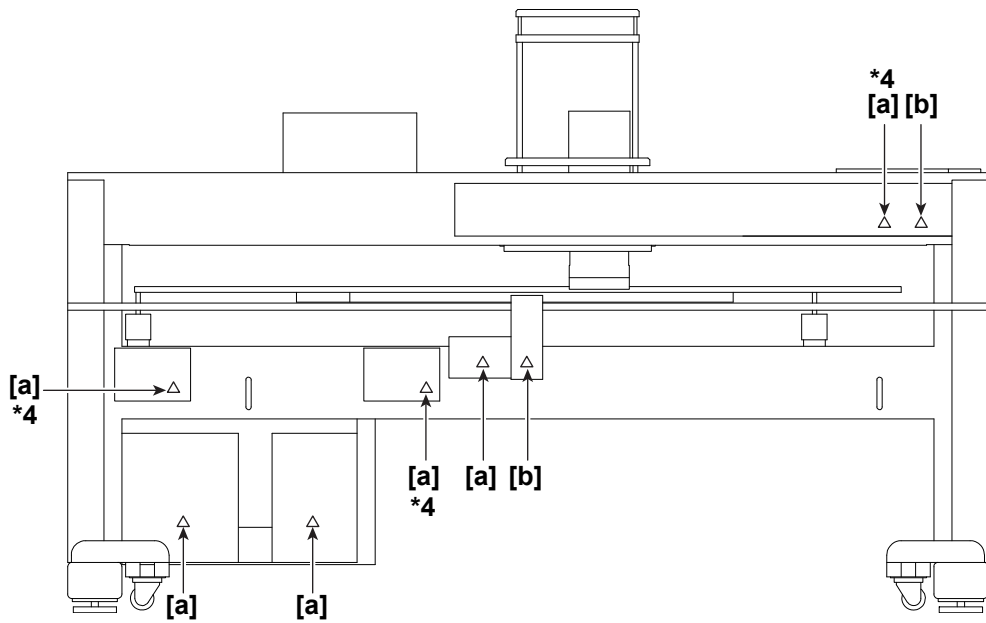

*1: Viewing X-axis drive system belt cover from side

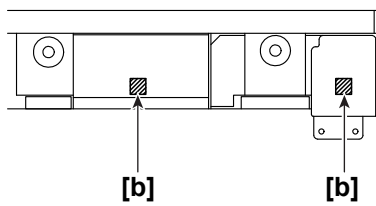

*3: Viewing power supply box from top

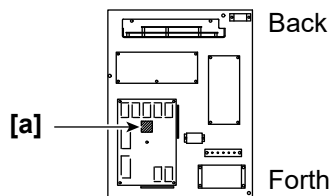

*4: [a] is affixed also to X-axis / Y-axis / Main shaft driver card base located to the inside of the cover.

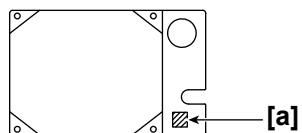

4. Inspection before starting work

Before starting work, execute inspection (including cleaning, lubrication) of each part.

Spot	Check
Covers	Covers might have been attached incorrectly.
Upper thread	The thread might have been passed incorrectly to each part. The tension might have been inadequate. The thread might have been entwined around frame/drive system.
Under thread	The under thread (bobbin case) might have been set to rotary hook incorrectly. The tension might have been inadequate.
Needle	The needle might have bent. The direction of needle might have been wrong. The needle might have been broken.
Rotary hook	Cleaning/lubrication might have been performed in inadequate frequency.
Tension base switch	The switch of head to use might have been turned ON. The switch of unused head might have been turned OFF.

Chapter 2

Name and way to use of each part

1. Name of each part	12
2. How to use each part.....	14
3. Functions that must be used practically	29

1. Name of each part

Only the main parts are shown here. For details, refer to the separate parts list.

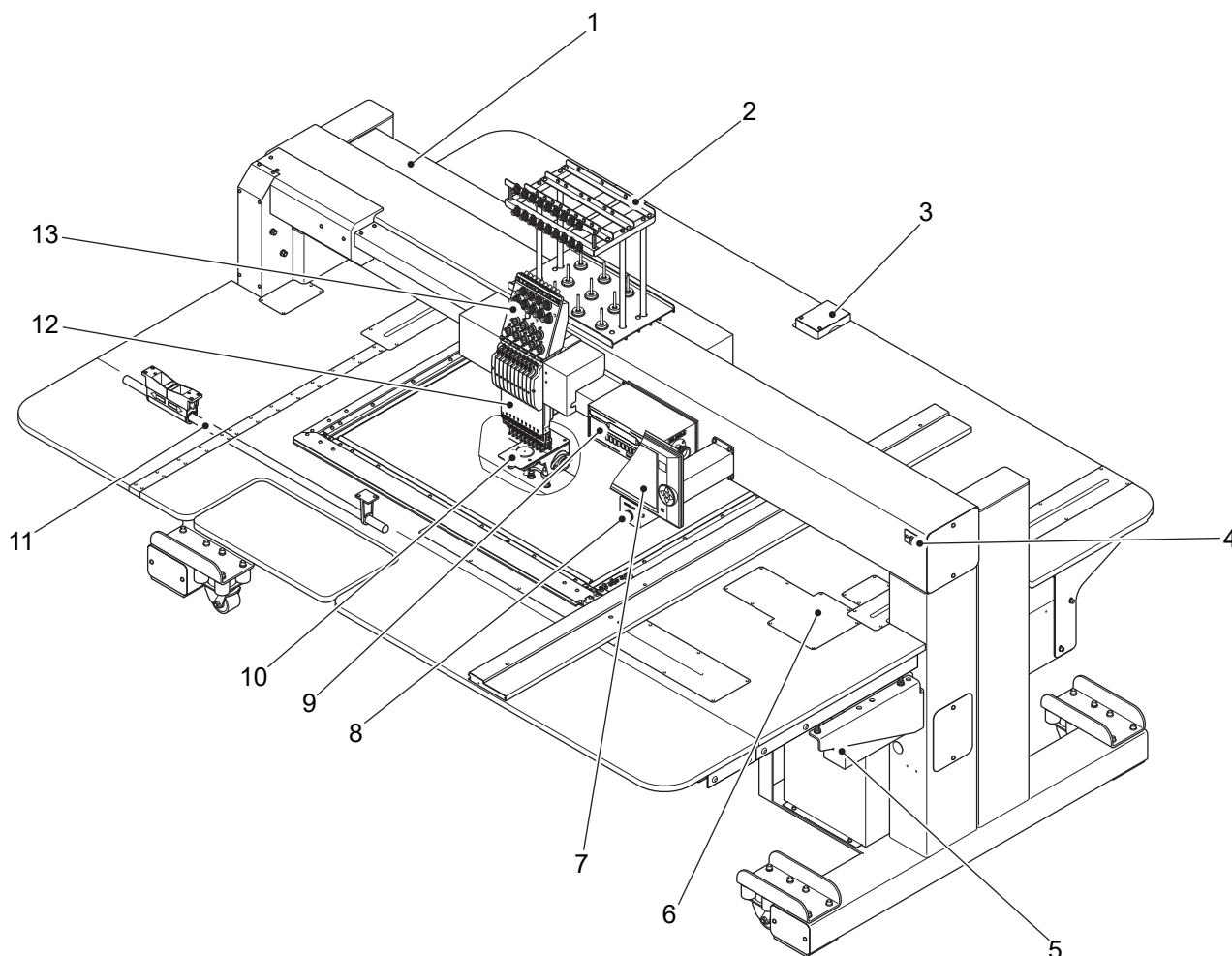

- | | |
|--------------------------------|----------------------------------|
| 1. Main shaft motor | 7. Operation panel (→p.20) |
| 2. Thread course (→p.88) | 8. Emergency stop switch (→p.17) |
| 3. Y-axis motor | 9. Color change device |
| 4. LAN port (→p.22) | 10. Rotary hook base |
| 5. Power supply switch (→p.14) | 11. Bar switch (→p.19) |
| 6. X-axis motor | 12. Needle bar case |
| | 13. Tension base (→p.23) |

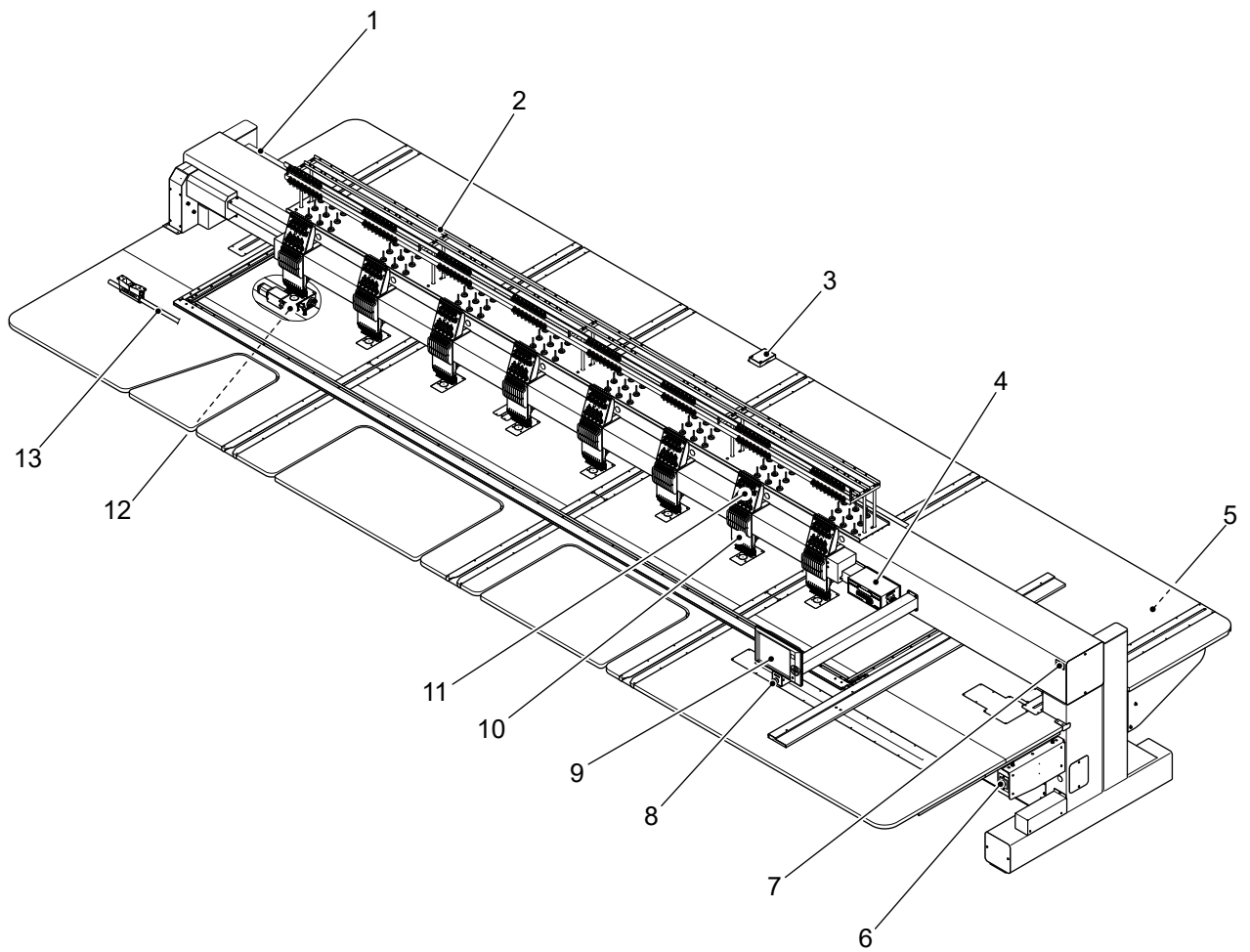

- | | |
|---------------------------------|-----------------------------------|
| 14. Main shaft motor | 20. LAN port (→p.22) |
| 15. Thread course (→p.88) | 21. Emergency stop switch (→p.17) |
| 16. Y-axis motor | 22. Operation panel (→p.20) |
| 17. Color change system | 23. Needle bar case |
| 18. X-axis motor | 24. Tension base (→p.23) |
| 19. Power supply switch (→p.14) | 25. Rotary hook base |
| | 26. Bar switch (→p.19) |



2. How to use each part

2-1. Power supply switch

When turning ON the power, set the power switch to "ON". When turning OFF the power, set this switch to "OFF". If the emergency stop switch is pressed or the power is shut off during operation, the power switch will be positioned at the middle position.

When Signal Tower is equipped (→ p.16)

CAUTION

-  To turn ON the power again, wait for 30 seconds or more. The system sometimes may not start up normally.
-  Do not turn ON the machine power with the USB memory connected to the operation panel. The system sometimes may not start up.

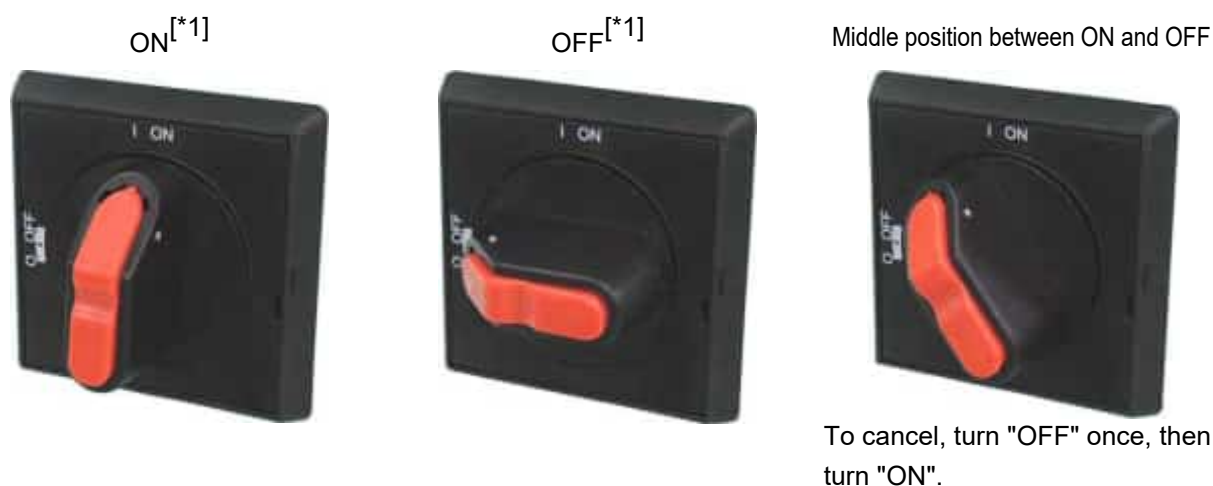

[*1]

About symbol signage of the power supply switch

"| " Power switch : ON

"O " Power switch : OFF

To lock the power switch, use the padlock.



There are also following types depending on the spec.

ON[*1]



OFF[*1]



Middle position between ON and OFF



[*1]

About symbol signage of the power supply switch

"| " Power switch : ON

"O " Power switch : OFF

To cancel, turn "OFF" once, then turn "ON".

To lock the power switch, use the padlock.



Padlock (Commercial item)

[When Signal Tower is equipped]

WARNING

 To perform cleaning, lubrication and greasing, be sure to turn OFF the main power switch. You may sustain severe injuries due to being entangled by moving machine.

When Signal Tower is equipped, twin type power supply switch can be selected.

Twin type power supply switch

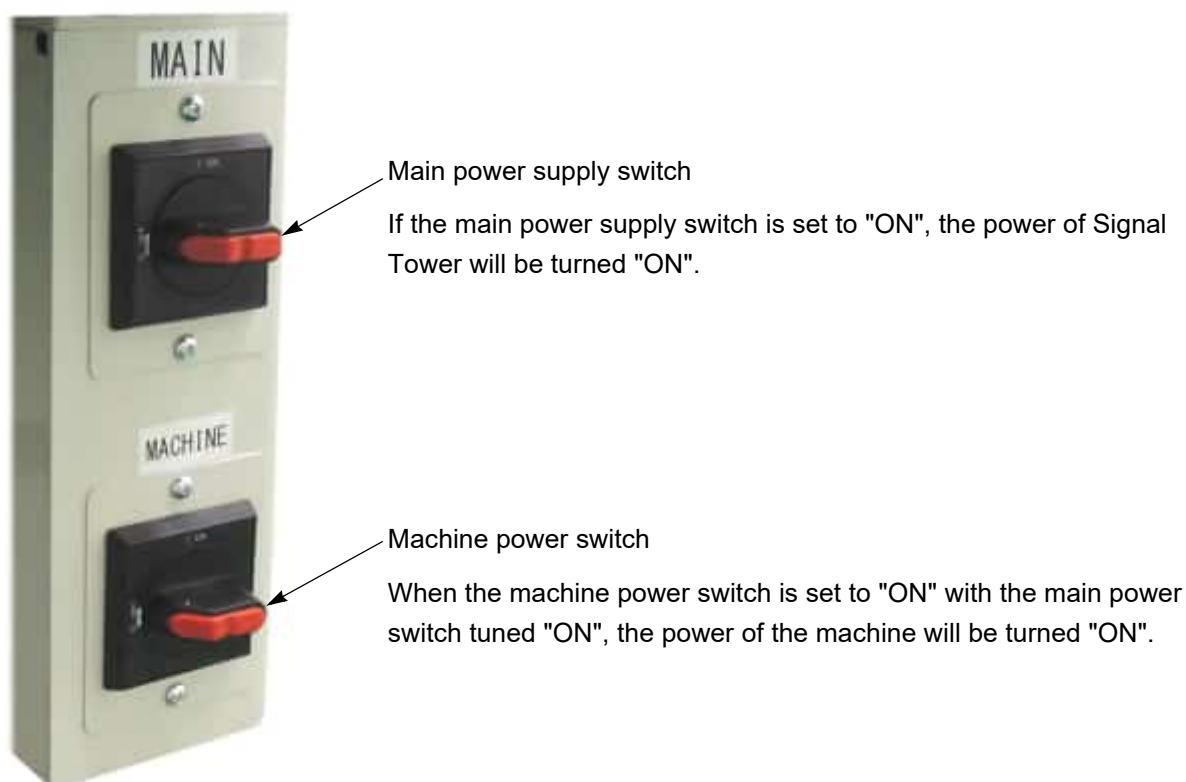

(1) How to turn ON the power

1. Set the main power supply switch to "ON".
2. Set the machine power supply switch to "ON".

(2) How to turn OFF the power

1. Set the machine power supply switch to "OFF".
2. Set the main power supply switch to "OFF".

2-2. Emergency stop switch

The emergency stop switch is equipped as a measure for safety. There are following two types depending on the model. Pressing this switch during operation will turn OFF the power and stop the machine. At this time, the power switch will be switched to the middle position.



To lock the emergency stop switch in the right photo, use the padlock.



Padlock (Commercial item)

[How to resume]

- (1) Turn the switch to the right. The lock will be released.



- (2) The power switch is set to "Middle position". Turn "OFF" → "ON" the power switch. At this moment, wait for 30 seconds or more.



In the case of twin type power supply switch, the main power of the machine will be turned OFF, and the machine power switch will be at "Middle position".

- (3) Execute "Power Resume" manually. (→p.122)

[When the power is shut off during working]

When the power is shut off due to cause like the power failure, restart sewing according to the following procedure.

! CAUTION

- ⊘ When performing this operation, do not put your hands, etc. on the table. Moving the frame could injure you.

- (1) After the electricity is connected and the power starts up, press icon G. Code No.2E3 will be reset.

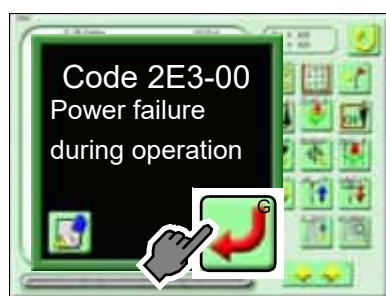

- (2) Press either one of following two icons according to sewing condition. Pressing icon will move the frame.

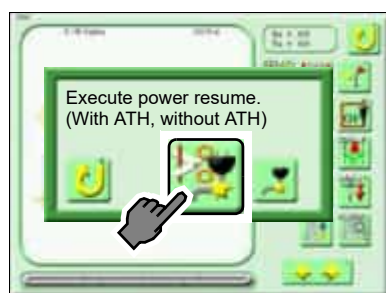

The frame will be moved after thread trimming.



The frame will be moved without thread trimming.

- (3) After Frame Travel, the frame may move forward by some stitches from the original position. Check the frame position, then restart sewing after performing Frame Back.

2-3. Bar switch

CAUTION

ⓘ Before starting the machine, pay enough attention to the surrounding safety. Moving needle bar and/or frame could injure you.



(1) During stop

Move the bar switch to the right and release it immediately.	Operation starts.
Move the bar switch to the right and hold it at that position.	The machine will work slowly. When released, the machine will run normally.
Move the bar switch to the left and release it. (up to 10 stitches)	<p>The head with thread breakage will move its presser foot to FB position and perform Frame Back by one stitch unit. FB position: refer to p.31.</p> <p>The head without thread breakage will move its presser foot to the retractable position and perform Frame Back or Frame Forward by one stitch unit. Retractable position: refer to p.31.</p> <p>Frame Back: This function makes the frame move to the direction which stitches return with the needle bar stopped.</p> <p>Frame Forward: This function makes the frame move to the direction which stitches advance with the needle bar stopped.</p>

<p>Move the bar switch to the left and hold it at that position. (11 stitches or more)</p>	<p>The machine will continue Frame Back/Frame Forward. Even if you release it, the machine will not stop.</p> <p>Frame feed amount can be selected among 1, 3 and 5 stitches. (→ p.238)</p> <p>Moving it to the left again will cause the machine to stop FB/FF.</p>
--	--

(2) During operation

<p>Move the bar switch to the left and release it.</p>	<p>Operation stops. The presser foot stops at the stroke upper dead point of the presser foot.^[1]</p>
<p>Move the bar switch to the right and hold it at that position.</p>	<p>The embroidery speed will go down, and become slow operation.</p>

[1]The presser foot will stop at the position according to "Presser foot setting". (→p.126)

2-4. Operation panel

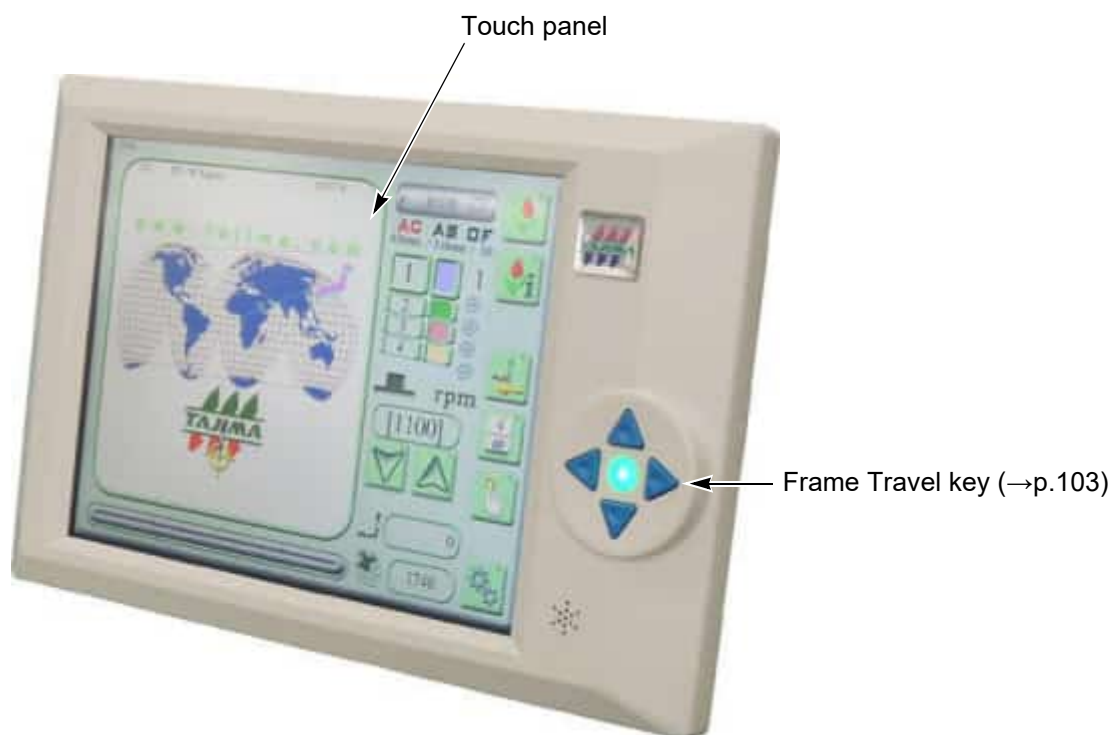

2-5. USB port

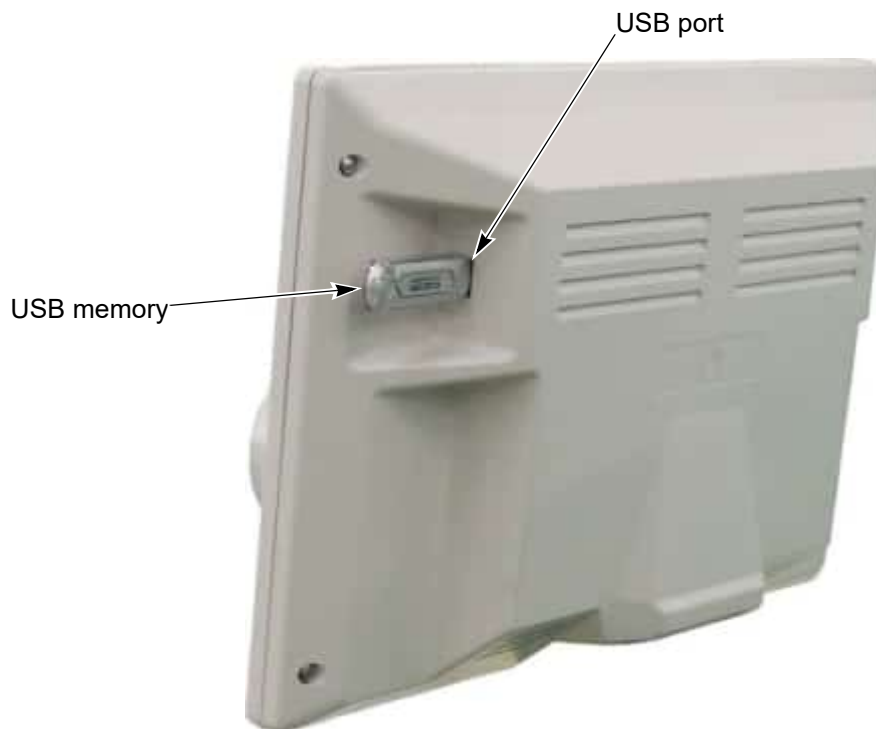







Please prepare a commercial item for the USB memory. The USB memory is used for the following cases.

1. When registering a design stored in the USB memory into the machine memory.
2. When saving the design registered in the memory of the machine into the USB memory
3. When the software of the machine is upgraded

Some type and/or capacity of the USB memory could not be used for this machine. In this case, buy the USB memory recommended by Tajima. For details, consult the distributor.

CAUTION

-  Do not turn ON the machine power with the USB memory connected to the operation panel.
-  Do not insert the USB memory in the state of dirt or dust attached to the inside of the connector.
-  Some kind and capacity of the USB memory may not be used for this machine. In this case, please buy other the USB memory.
-  Do not push / pull the USB memory during operation of the machine.
-  Insert the USB memory slowly and gently. If the USB memory is inserted impetuously, it could be damaged.
-  Insert the USB memory upright against the port (insertion slot). Oblique insertion could damage to inside circuit board due to interference of connector with the circuit board.
-  Start operation after inserting the USB memory for five or more seconds.

2-6. LAN port

When connecting the personal computer with the machine, connect the LAN cable to the LAN port of the machine.

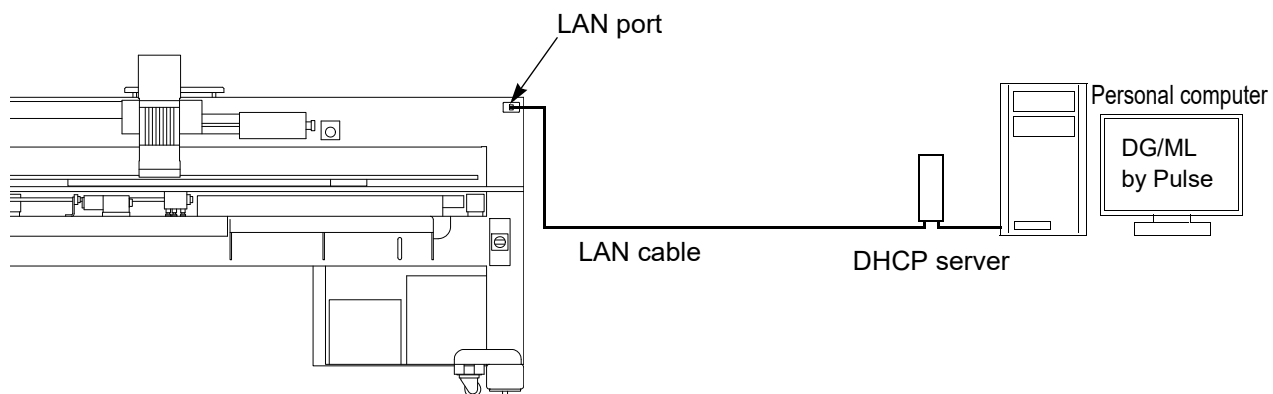

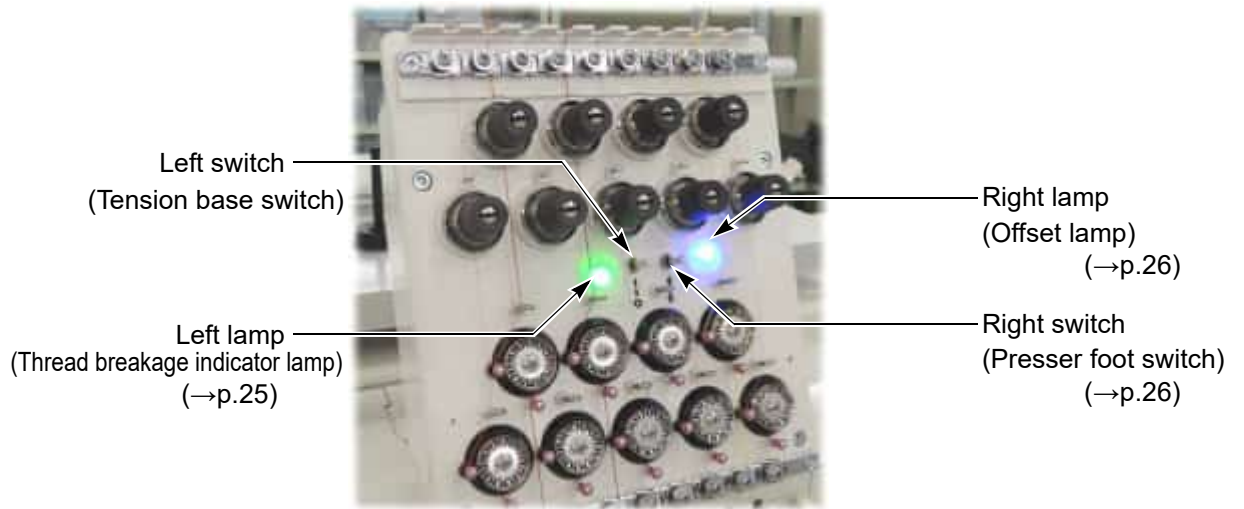

2-7. Tension base



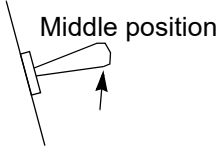

(1) Left switch

a. Set the left switch to middle position at the head to operate.

Left switch	Lighting condition of left lamp
 <p>Middle position</p>	 <p>Unlit → Green</p>

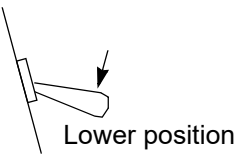
b. Set the left switch to bottom position at the head to suspend.

Left switch	Lighting condition of left lamp
 <p>Lower position</p>	 <p>Green → Unlit</p>

c. When you want to perform return stitching in next start of sewing at the head with thread breakage, raise the left switch once. (→p.29)

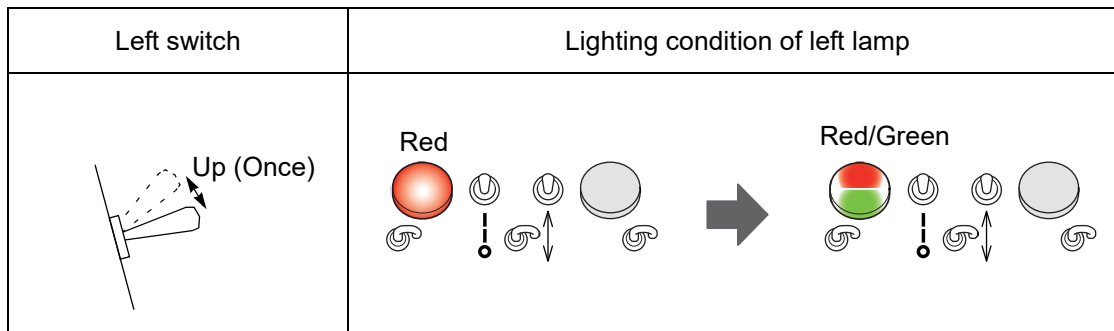

d. When you want to perform return stitching in next start of sewing at the head without thread breakage, raise the left switch twice. (→p.30)

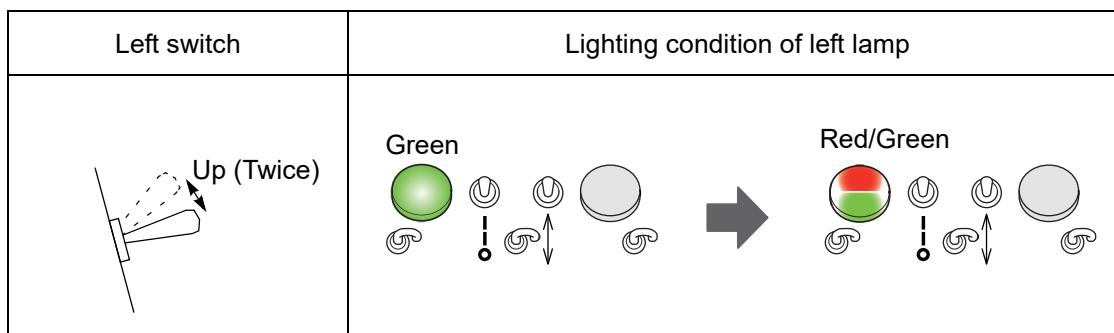



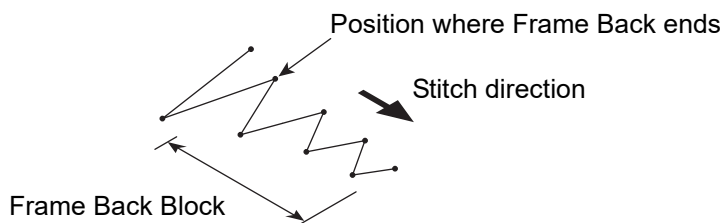
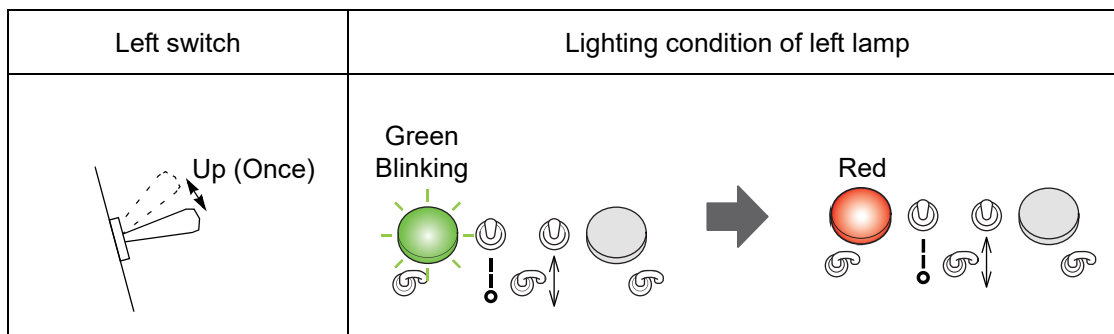

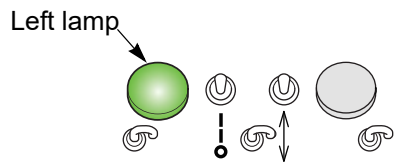

e. When you want to sew from the end position of Frame Back after completing Frame Back at the head without thread breakage, raise the left switch once.



(2) Left lamp





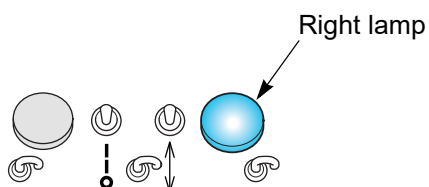

<p>Lit in green</p> 	<p>It is in the middle of sewing or ready for sewing.</p>
<p>Blinking in green</p> 	<p>During Frame Back, the lamp at the head without thread breakage blinks in green.</p>
<p>Lit in red</p> 	<p>The upper thread has broken.</p>
<p>Blinking in red</p> 	<p>The under thread has broken.</p>
<p>Unlit</p> 	<p>The needle bar is suspended.</p>
<p>Lit in red/green</p> 	<p>Return stitches will be performed at start of sewing. (→p.29)</p>

(3) Right switch

When the machine stops, moving up/down the right switch will cause the height of the presser foot at the head to move up/down in three steps. (→p.31)

(4) Right lamp

<p>Lit in blue</p> 	<p>During stop of the machine in the middle of sewing, if the frame is moved manually, right lamps at all heads will be lit in blue.</p> <p>This function is effective only when "Return the frame after manual frame travel" is set to "Yes". (→p.252)</p>
<p>Unlit</p> 	<p>Auto Data Point Return Function does not work.</p>
<p>Blinking in yellow</p> 	<p>Abnormality occurred (an error except upper/lower thread breakage).</p>
<p>Lit in yellow</p> 	<p>It notifies the head adjusting the lower dead point of the presser foot.</p>

2-8. Presser foot

There are following types of presser foot. Use the presser foot suitable for your purpose. The presser foot is supplied as a sample of accessory except the one equipped with the machine. Please purchase it as necessary.

(1) PRESSER FOOT :STANDARD :3MM DIA.



Item mounted in the machine

[Purpose]

Standard presser foot

(2) PRESSER FOOT :BOWL :3MM DIA.



[Purpose]

Presser foot for quilt sewing

(3) PRESSER FOOT :BOWL :RESIN :3MM DIA.



[Purpose]

Presser foot for quilt sewing

It is usable for bad passing material like enamel.

Plastic part is consumable. Plastic part only can be replaced.



(4) PRESSER FOOT :VERGE SEWING :2.5MM DIA.



[Purpose]

It is suitable to sew at the edge of the gauge frame.



3. Functions that must be used practically

3-1. To perform return stitching at start of embroidery

When the machine stops, raising the left switch of the tension base at desired head will cause the head to perform return stitching at next start of sewing.



This function will make the machine work regardless of the setting of parameter "23 Return stitch".

(1) To perform return stitches when thread breakage is detected at 1 head only

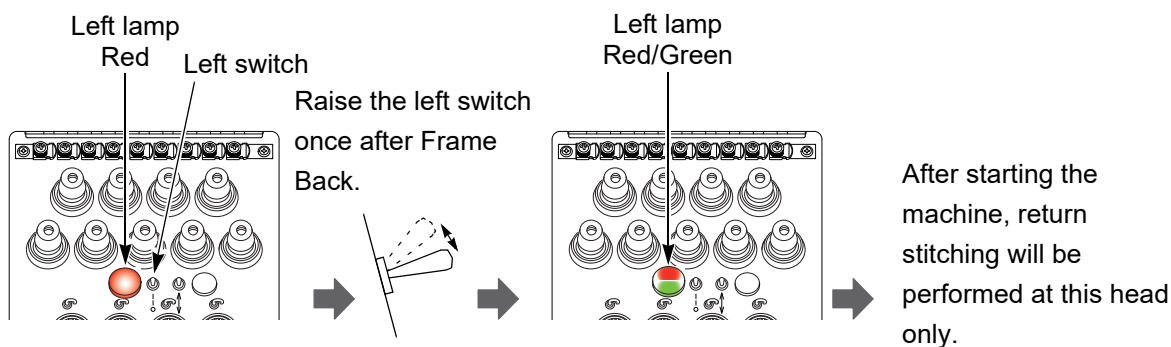

(2) To perform return stitching when thread breakages are detected at plural heads

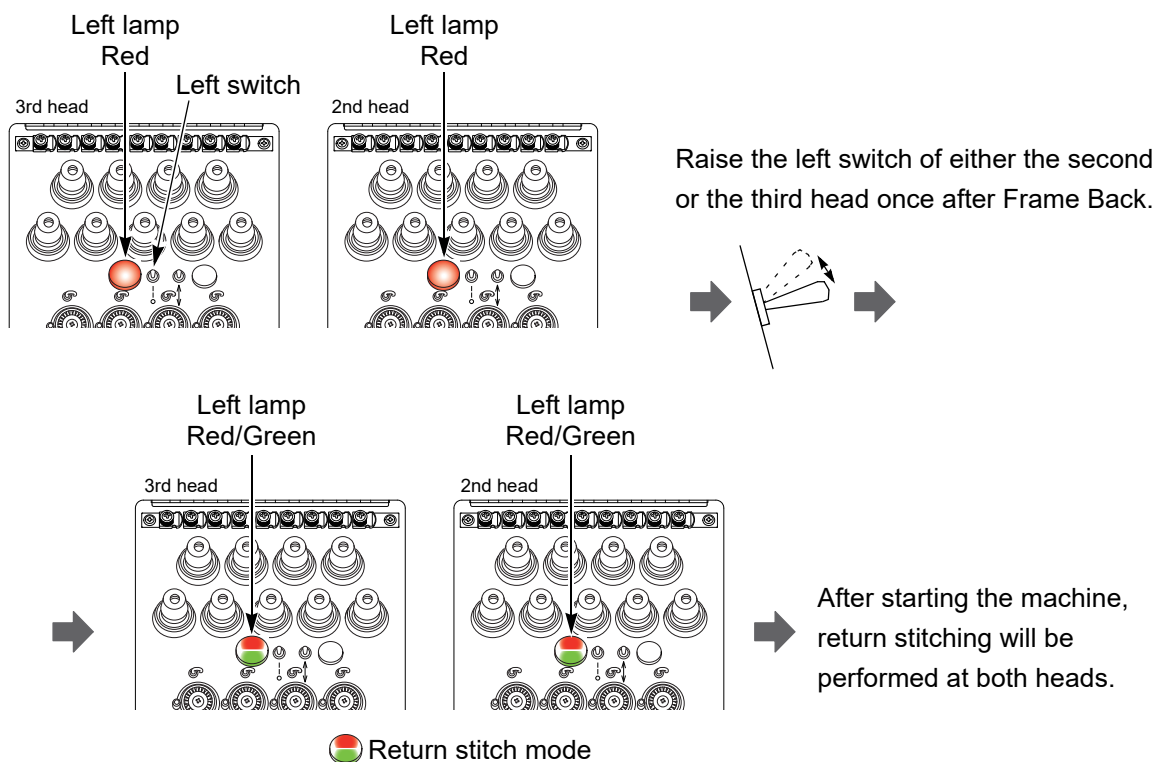

To cancel return stitching mode at this time, raise the left switch of either the second or the third head twice. The left lamp at both heads will be switched to light up in red.

(3) To perform return stitching without thread breakage

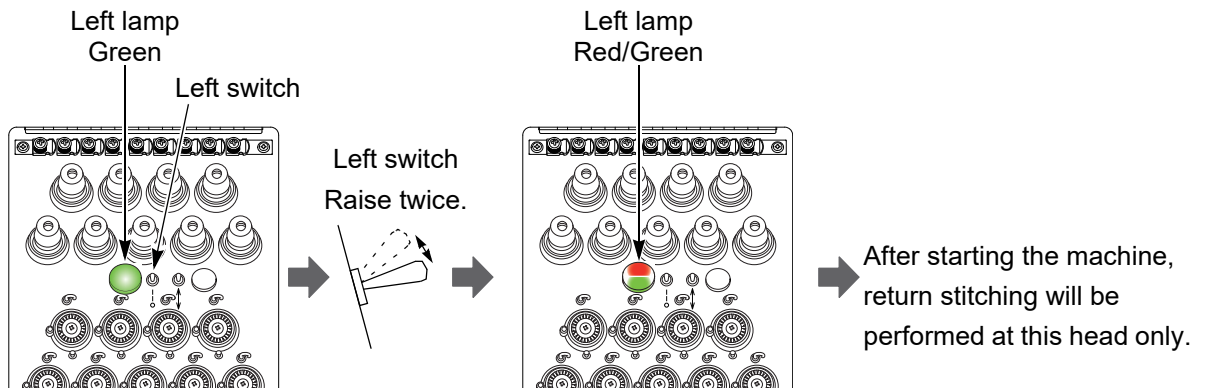

3-2. To lower/raise the presser foot

When the machine stops, if you move the right switch to up/down, the height of the presser foot at the head will go up/down in three steps. It is also possible to start operation even when the presser foot comes down.

To raise or lower presser feet at all heads at the same time, refer to the detail page. (→p.125)

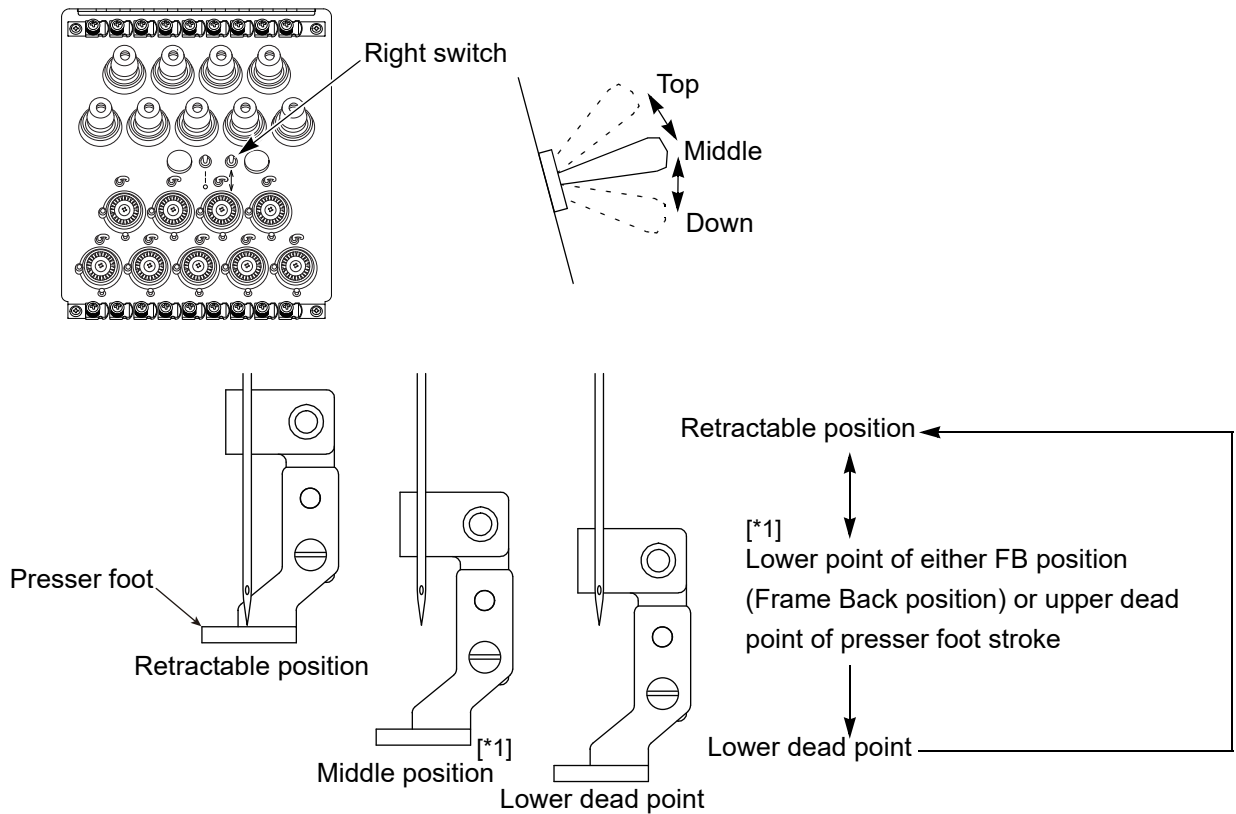

Retractable position	Position of the presser foot after turning ON the power, after setting data, at Frame Travel, after ATH, at color change, etc. During Frame Back or Frame Forward, the presser foot position at the head without thread breakage
FB position	During Frame Back, the presser foot position at the head with thread breakage
Lower dead point	Presser foot lower dead point (The position that lowered most) When you want to check the thickness of the fabric, set to this position.

3-3. To notify the operator that the position of the frame is misaligned

If the frame is moved by the following operation while the machine stops in the middle of sewing, right lamps at tension bases of all heads will be lit in blue. Thus, the machine will notify the operator that the frame is not in the original position.

This function is effective only when "Return the frame after manual frame travel" is set to "Yes". (→p.252)

1. Manual Frame Travel
2. Return to the start position
3. Offset Return
4. Frame Travel to an optional position

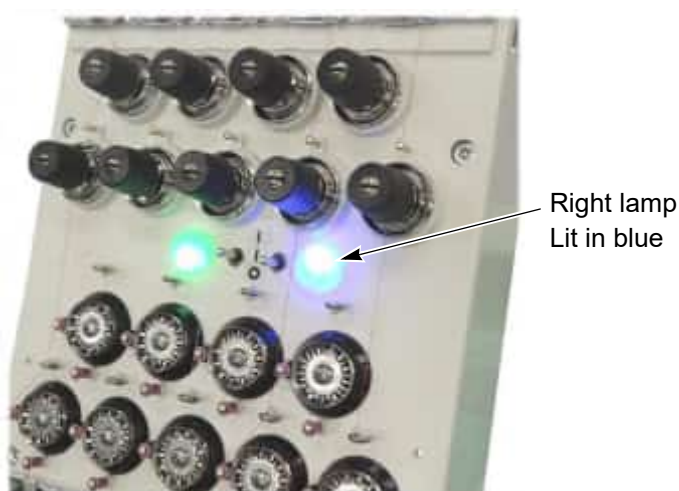

[Examples of use]

(1) Stop the machine in the middle of sewing, and pull out the frame to the front. The right lamp will be lit up.

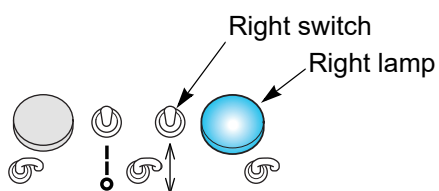

Moving up the right switch during lighting up of the right lamp will turn off right lamps at all heads and make this function invalid. To make it valid, move up the right switch again.

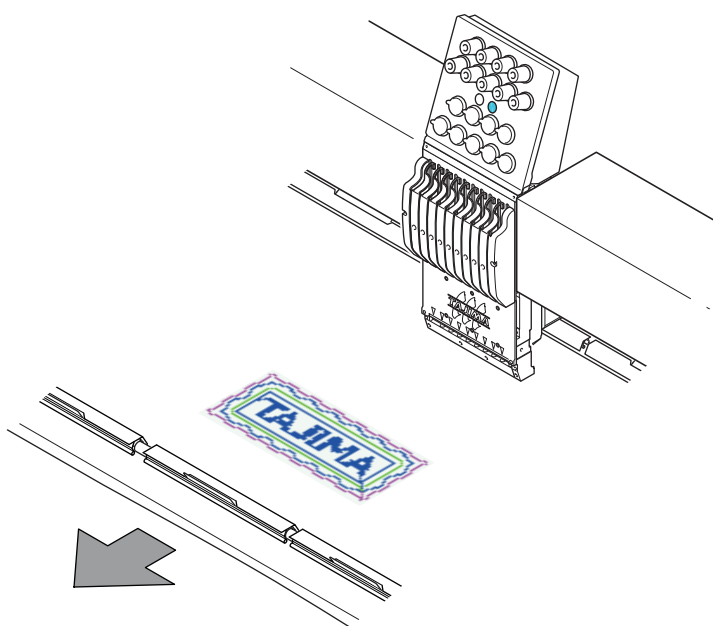

(2) To return the frame to the original position after checking the design, perform the following operation.

Move the bar switch to the left and release it.:

The frame will return to the original position.

Move the bar switch to the right and release it immediately.:

The frame will return to the original position and the machine will start operation.

Bar switch

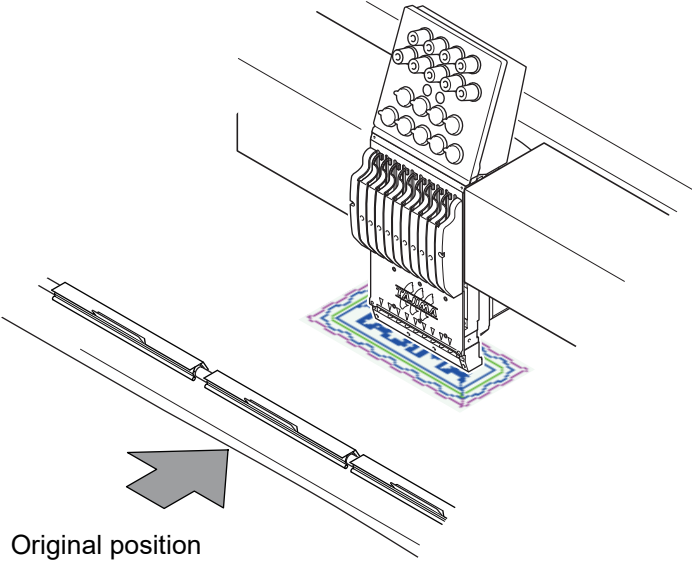
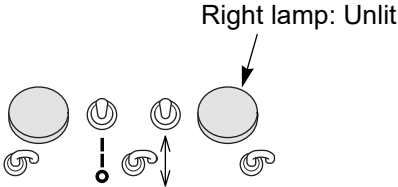

Chapter 3 Screen

1. Basic screen	36
2. Sewing mode screen, Embroidery mode screen.....	44
3. Input operation.....	48

1. Basic screen

1-1. Main screen (Screen 1010)

When the power is turned ON, the following screen will appear. From this screen, setting or operation will be started.

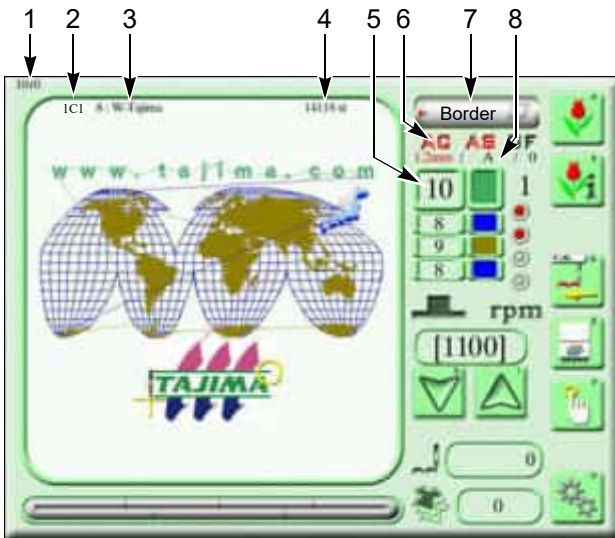

1. Screen number (1010)
2. Stop factor (It will be displayed during stop of the machine.)
3. Design name

[H] 8 : Flower
 ↑ ↑ ↑
 Machine memory number Design name
 When setting the design data saved in sewing mode screen, H will be displayed.

4. Total number of stitches of design
5. Needle bar No. of current step
6. Setting condition of Automatic Color Change, Auto Start and Automatic Offset. Red letters show the setting now.

AG AS OF
 ↑ ↑ ↑
 Automatic Color Change Auto Start Automatic Offset





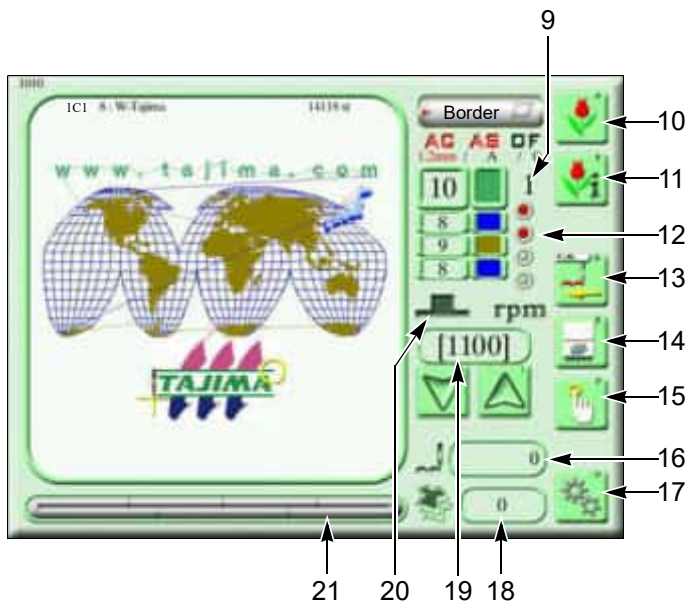

7. Currently selected frame type
8. Presser foot preset value of current step

1.2 mm / A / 0
 ↑ ↑ ↑
 Presser foot lower dead point Presser foot stroke Presser foot timing

Red letters means that the red value has been changed at "Step unit setting". (→ p.212)

When data set is performed after inputting the design data in which the presser foot setting is registered, all letters will be red.



- 9. Current needle bar step No.
- 10. Design selection screen (→p.47)
- 11. Screen of detailed design information (→ p.101)
- 12. Auto Color Change Offset (→p.193)
- 13. Current setting value of Frame Back (FB) / Frame Forward (FF)
 - FB  D
 - FF  D
- 14. Manual color change screen (→p.116)
- 15. Manual operation screen
- 16. Current number of stitches
- 17. Setting item screen (→p.233)
- 18. The number of times that have been sewn up to now
Even if the power is turned OFF/ON, counting will continue.
- 19. Maximum speed (→p.102)
- 20. Current main shaft angle
 -  Fixed position
 -  Outside of range of fixed position
- 21. Progress of sewing
- 22. End position 
- 23. Start position 
- 24. Current needle position 

When "Sidekick [V2]" is selected in the setting of the network, Sidekick icon will appear as shown in the figure below.

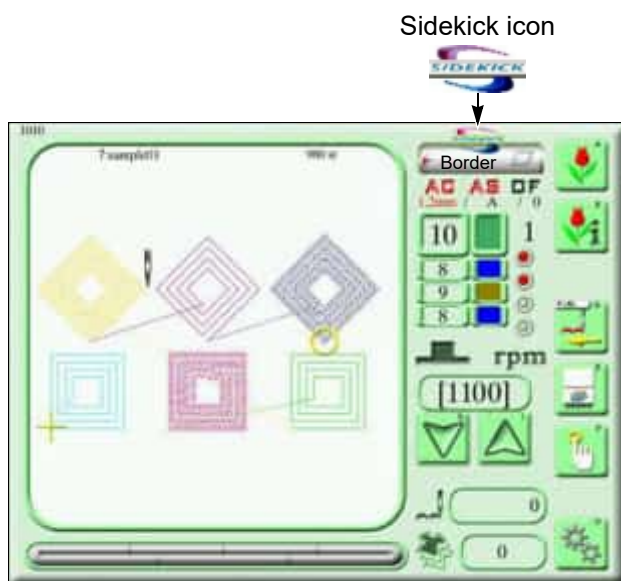

1-2. USB memory screen (Screen 3100)

Screen 1010 → To set USB memory

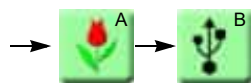

It is possible to select plural designs on this screen.

The below illustration shows an example that four designs are selected.

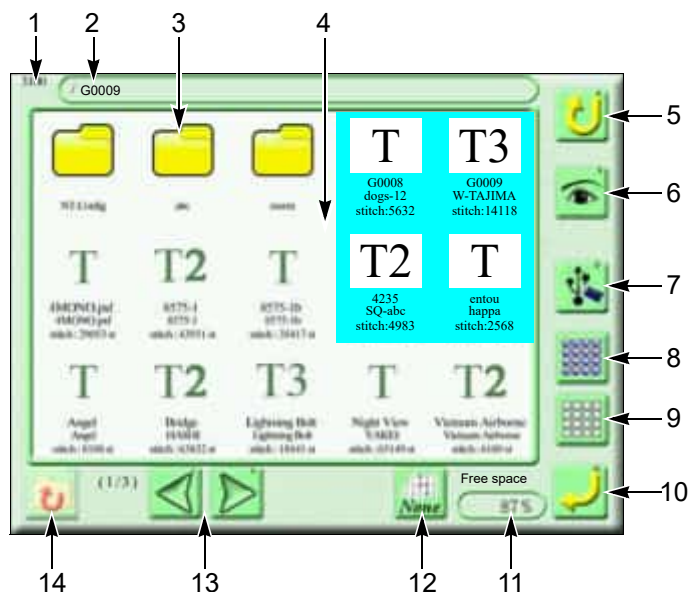

"Selected / not selected" will be switched each time the design is selected.

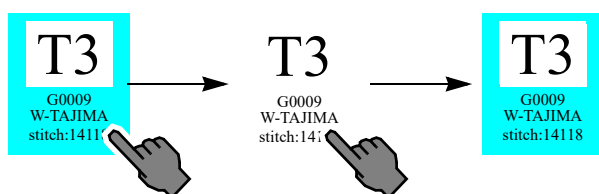

T ← Saving format of design
 G0003 ← File name (indicated on personal computer)
 MADELENE ← Design name
 stitch:30034st. ← Number of stitches of design

Saving format of design

- T: TAJIMA format (DST)
- T2: TAJIMA binary format (TBF)
- T3: TAJIMA integrated file (TCF)

Depending on saving format of the design, the design except above one will be displayed.

1. Screen number (3100)
2. File name of selected design
3. Folder
It is possible to display up to the third layer directory.
4. Design saved in the USB memory
5. The screen returns to the screen 2000.
6. Images of all designs are displayed when pressing this icon without selecting any design. Only an image of this design is displayed when pressing this icon with a design selected.
7. Deletion of a design
It will be displayed only when design is selected.
8. Select all designs.
9. Selecting the design will be canceled.
10. Decide the design.
11. Machine memory capacity (40,000,000 stitches)
Free space will be displayed as "%". If remaining space becomes 20% or less, remaining number of stitches will be displayed.
12. Rearrangement of design (folder is excluded)
None: Registering order
Time: Updating order
Name: Alphabetical file name order
13. Page switching (Only when the second page or after exists)
14. If the folder is selected, the layer directory will be returned to the upper one.

When reading a design (File name: G003) saved in the USB memory by a personal computer, the display will be given as below.

Saving format	Indication on personal computer	Use
T3	G0003.TCF	Data integrating CT0, DGF and TBF of T2
T2	G0003.CT0	Color Change Sequence, Start Position
	G0003.DGF	Design data in personal computer
	G0003.TBF	Stitch data of TAJIMA binary format
T	G0003.DST	Stitch data of TAJIMA ternary format

1-3. Presser foot preset saving screen

This screen will save the setting value (described below) of the presser foot for each design.

- (1) Presser foot lower dead point (→p.126)
- (2) Presser foot stroke mode (→p.127)
- (3) Presser foot stroke (→p.127)
- (4) Presser foot timing (→p.127)
- (5) Presser foot F.B. lower dead point (→p.127)

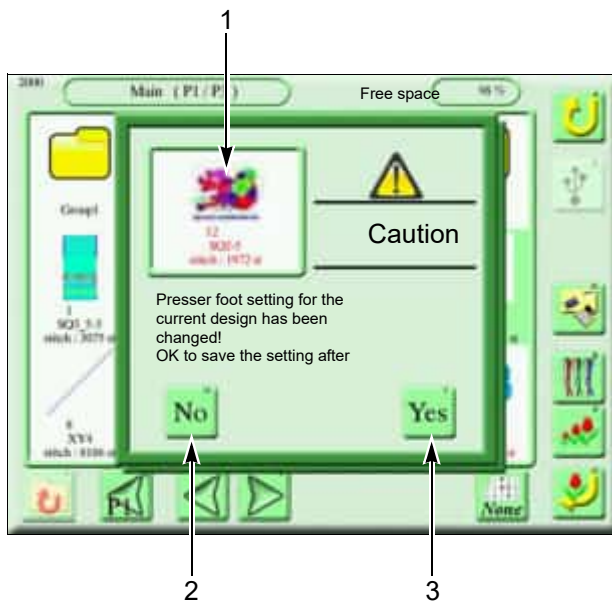

1. Current design (Currently set design data)
2. Do not save the setting value of the presser foot in this design data. (Return to the value before change.)
3. Save the setting value of the presser foot in this design data.

This screen will be displayed under the following conditions.

- (1) When the data of the design A is set again after changing the data of the current design (design A)

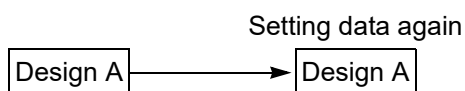

- (2) When the data of the design B is set after changing the data of the current design (design A)

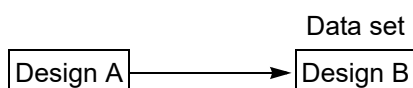

1-4. Data set screen

Select the design and enable sewing. (Data set)

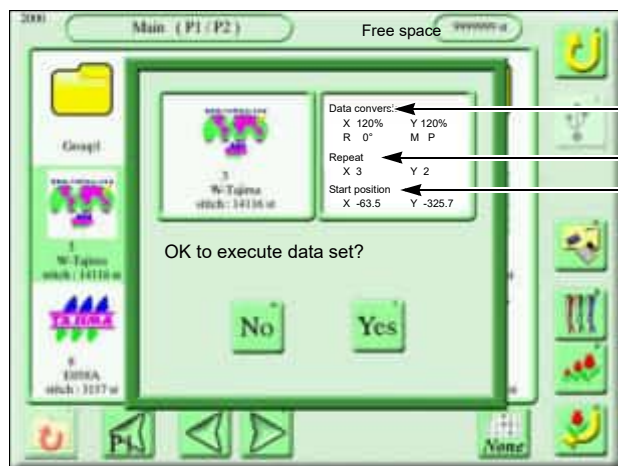
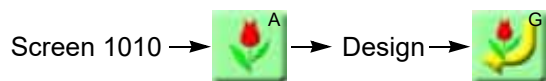

1. Setting for scaling up/down of design
2. Setting of repeat
3. Start position
Frame position where machine started sewing last time

1-5. Needle bar selection screen (Screen 2010)

Perform general settings about needle bar.

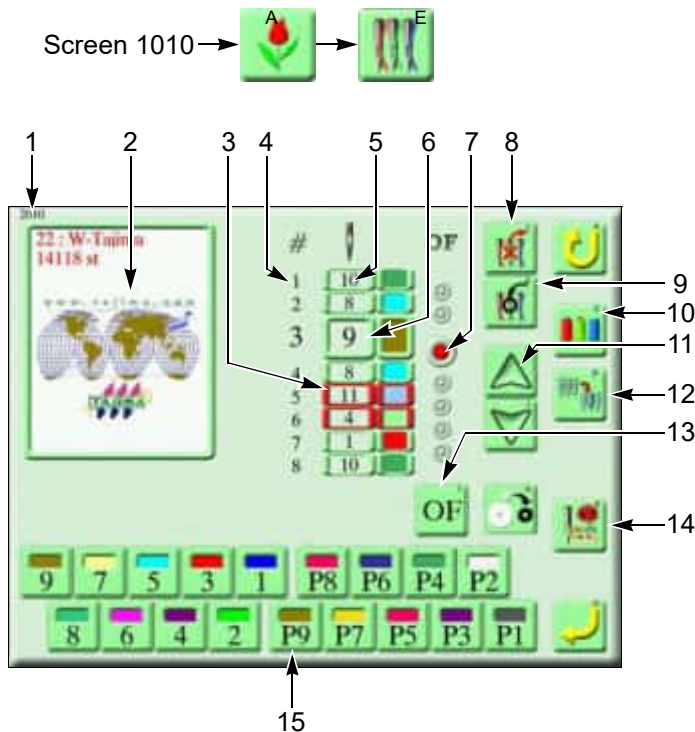

1. Screen number (2010)
2. Design of which data is set
3. Red frame indication of the step
Step that sewing condition was set at "Step unit setting" individually (→p.212)
4. Needle bar step
The section divided by a color change code in the design. The first step is called Step 1.
5. Needle bar No.
In the example of the left figure, step 1 will be sewn at the needle bar number 10.
6. Cursor
Step to perform needle bar selection from now
7. Offset lamp (→p.193)
After step 3 is finished, the frame will move to the offset position.
8. Deletion of needle bar step (→p.211)
9. Insertion of needle bar step (→p.212)
10. Needle bar color (→p.218)
11. Cursor movement key
12. Needle bar conversion (→p.217)
13. Auto Color Change Offset Setting (→p.193)
14. Step unit setting (→p.212)
Change sewing condition of the desired step.
15. Needle bar selection icon

2. Sewing mode screen, Embroidery mode screen

The machine memory function has sewing mode screen and embroidery mode screen.

- (1) Save the design to use for sewing (sewing design) into sewing mode screen (Pattern-List, Pattern1 to Pattern4, Pattern-Main).

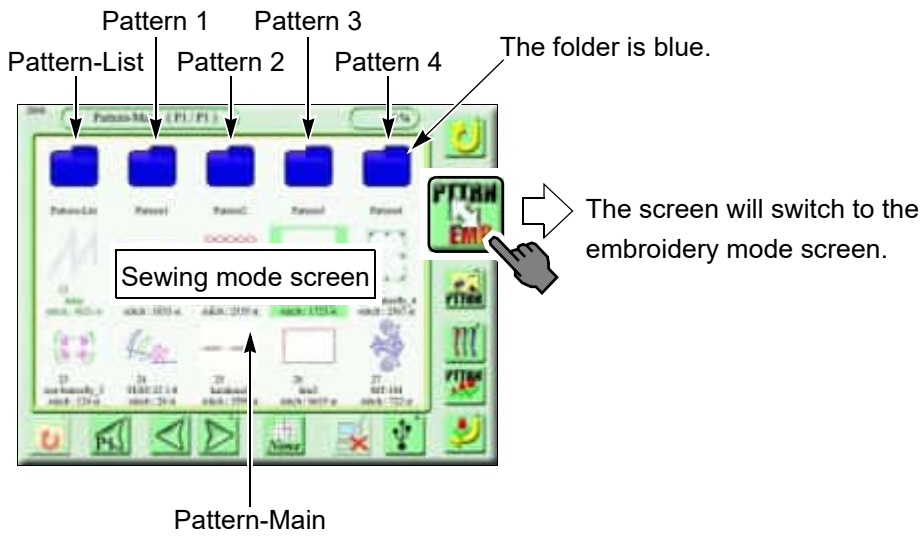
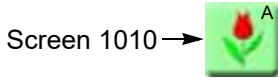

- (2) Save the design to use for embroidering (embroidery design) into embroidery mode screen (Group1 to Group5, Main).

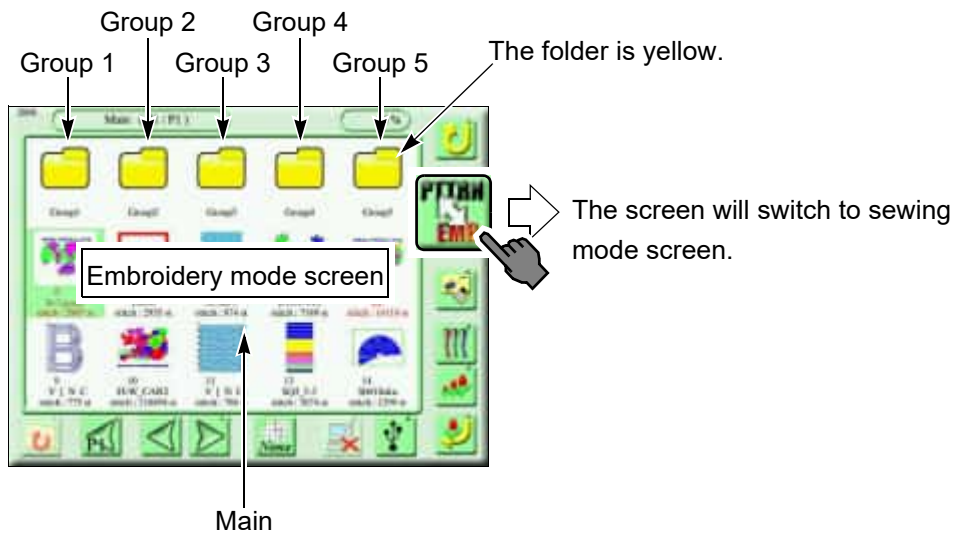
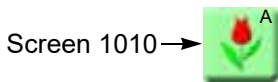

(3) Major differences in function between sewing design and embroidery design

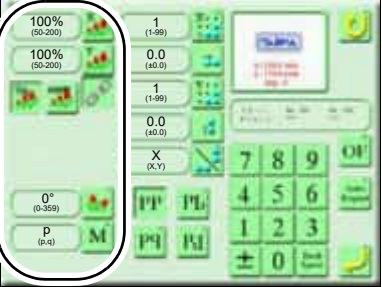
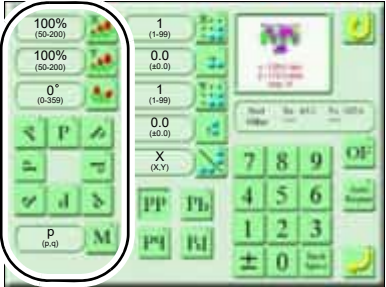
	Sewing design	Embroidery design
Data conversion	 <p>The screen display differs. (→p.194)</p>	 <p>The screen display differs. (→p.202)</p>
Design creation	Able (→p.169)	Unable
Design modification	Able (→p.74)	Unable
Arbitrary Block Setting	Able (→p.149)	Unable
Change of start position by manual frame travel	Perform exclusive operation. (→p.185)	Able (→p.103)
Test sewing	Able (→p.183)	Unable
Combination stitching of sewing design and embroidery design	Able (→p.164)	Unable
To change direction of sewing design and save it into machine memory	Able (→p.167)	Unable

2-1. Sewing mode screen (Screen 2000)

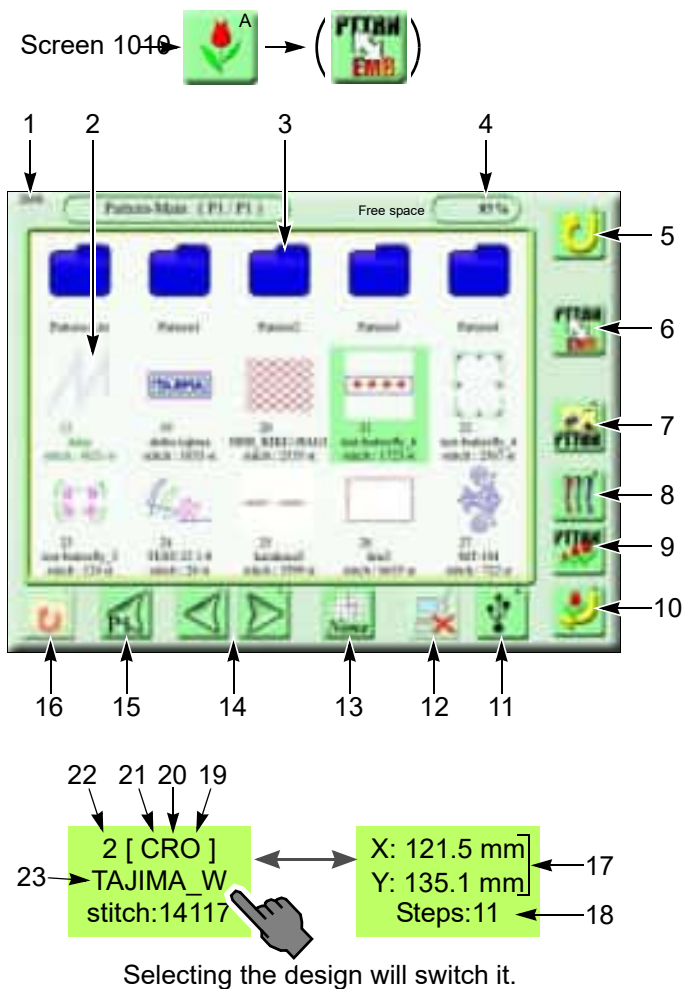

Select sewing design in the machine memory and perform edit of sewing design, change of needle bar order, and setting of repeat.



- 17. Design size (sewing space)
- 18. Number of steps
- 19. With setting of automatic offset
- 20. With setting for repeat
- 21. With setting for scaling up/down of design
- 22. Machine memory number
- 23. Design name



When there is no sewing design in the machine memory, icons 7, 8 and 9 will not be displayed.

- 1. Screen number (2000)
- 2. Sewing design saved in machine memory
- 3. Folder
Design data can be saved in the folder. It is not possible to change folder name (Pattern-List, Pattern1 to Pattern4).
- 4. Remaining number of machine memory
Free space will be displayed as "%". If remaining space becomes 20% or less, remaining number of stitches will be displayed.
- 5. Return to screen 1010.
- 6. Switch the screen to the sewing mode screen or the embroidery mode screen. (→ p.44)
- 7. Design edit screen
- 8. Current needle bar setting (→p.99)
- 9. Screen of scaling up/down and repeat of design
- 10. Determine the data set.
- 11. USB memory screen (→p.39)
- 12. Condition of connecting to DG/ML by Pulse
Connected Unconnected
 
- 13. Rearrangement of design
None: Registering order
Name: Alphabetical file name order
Time: Updating order
- 14. Scroll the screen.
- 15. Return the screen to P1
- 16. If the folder is selected, the screen will be returned to the "Pattern-Main" screen.

2-2. Embroidery mode screen (Screen 2000)

Select the embroidery design in the machine memory and perform edit of the embroidery design, change of needle bar order, and setting of repeat.

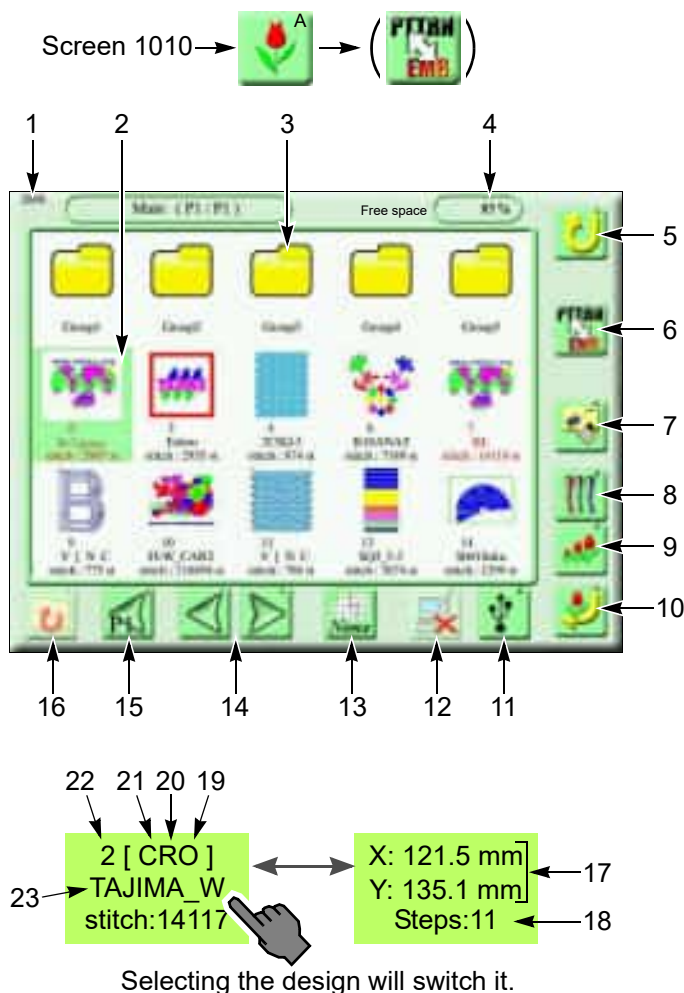

1. Screen number (2000)
2. Embroidery design saved in machine memory
3. Folder
Design data can be saved in the folder. It is not possible to change folder name (Group1 to Group5).
4. Remaining number of machine memory
Free space will be displayed as "%". If remaining space becomes 20% or less, remaining number of stitches will be displayed.
5. Return to screen 1010.
6. Switch the screen to the sewing mode screen or the embroidery mode screen. (→ p.44)
7. Design edit screen
8. Current needle bar setting (→p.99)
9. Screen of scaling up/down and repeat of design
10. Determine the data set.
11. USB memory screen (→p.39)
12. Condition of connecting to DG/ML by Pulse
Connected Unconnected
13. Rearrangement of design
None: Registering order
Name: Alphabetical file name order
Time: Updating order
14. Scroll the screen.
15. Return the screen to P1
16. If the folder is selected, the screen will be returned to the "Main" screen.

When there is no design in the machine memory, icons 7, 8 and 9 will not be displayed.

3. Input operation

3-1. To input value

When inputting the value, select the number icon, and press icon G.

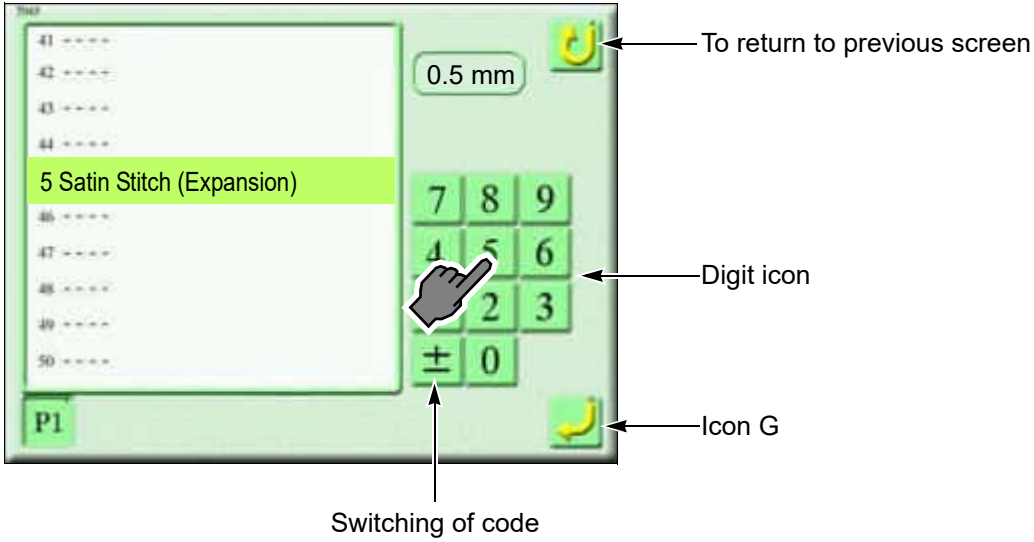

3-2. To input character

When inputting the character, select the character icon, and press icon G.

Switching of large letter/small letter

Movement of cursor

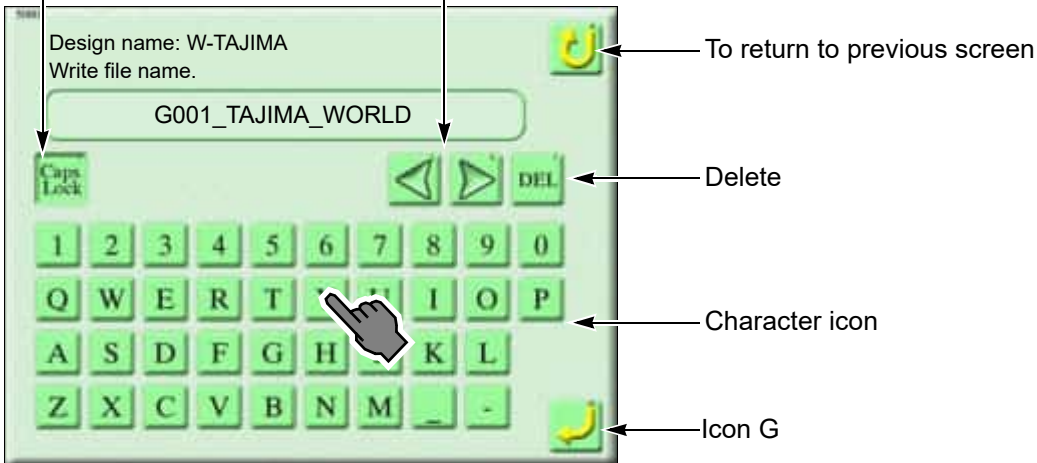

Chapter 4

Outline of functions

1. Condition data	50
2. Offset Frame Travel.....	52
3. Trace	55
4. Head selection.....	56
5. Return Stitches, Tie Stitches.....	58
6. Condensation sewing	59
7. To create the design, to modify the design	61

1. Condition data

When a design saved in the USB memory is registered into the machine memory, it is possible to register the condition data (three items below) together with the design into the machine memory. However, the design is limited to "T2" or "T3" saving format.

This function is effective only when the parameter setting "2 Condition data" is "Yes". (→p.268)

1. Color change sequence

The whole color change sequence included in the design can be registered into the memory of the machine. Therefore, it is unnecessary to set it again.

2. Start position

The frame position where the machine started stitching last time can be registered in the memory of the machine. Therefore, it is unnecessary to adjust the position of the frame.

3. Presser foot setting

The whole color change order included in the design can be registered in the memory of the machine. Therefore, it is unnecessary to set again. It is also possible to change the setting after data set.

Moreover, by setting the following four items after data set, each setting contents will be added in an design. Therefore, it is unnecessary to set again when you sew this design next time.

1. Data conversion (→p.194)

2. Design repetition (→p.197)

3. Automatic Offset (→p.188)

4. Presser foot setting (→p.212)

The following setting items can be saved / or cannot be saved depending on saving destination.

○ : Can be saved

× : Unable to save

Setting item	Saving into the machine memory	Saving into a USB memory		Saving from DG/ML by Pulse to memory of the machine
		T3, T2	T	
Color change sequence ^[1]	○	○	×	○
Start position	○	○ ^[2]	×	×
Data conversion	○	×	×	×
Design repetition	○	×	×	×
Automatic Offset	○	×	×	×
Presser foot setting	○	○ ^[3]	×	○

[1] Automatic Free Setting Offset included in the color change sequence is also included.

[2] When sewing the design between models with different sewing spaces, the start position may differ depending on the model.

[3] Only T3 can be saved in USB memory.

2. Offset Frame Travel

2-1. Automatic Offset

The frame will move to the registered position (Offset Position) automatically after completion of sewing. The frame will move to the start position automatically after starting operation.

[Examples of use]

- (1) The frame will move to the offset position automatically after completion of sewing.

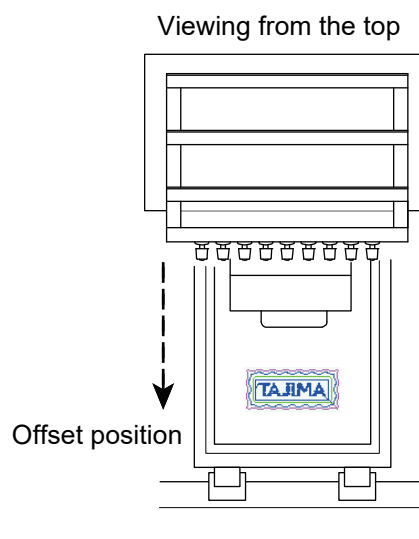

- (2) Replace the frame.

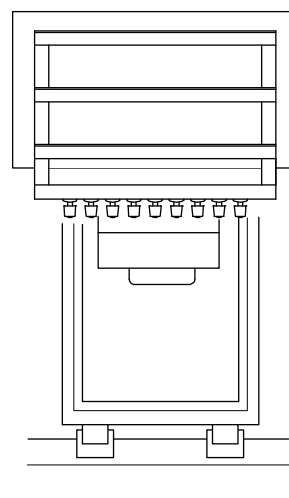

- (3) Start the machine operation.

After starting the machine operation, the frame will move to the start position automatically, then sewing will start. After completion of sewing, the frame will move to the offset point automatically.

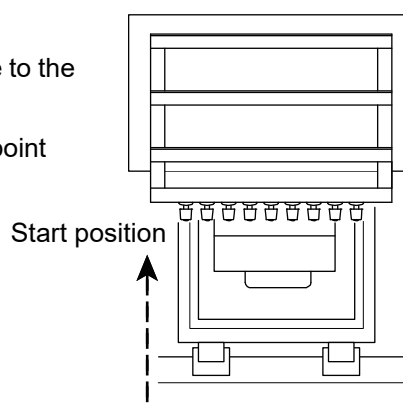

2-2. Automatic Free-Setting Offset

In addition to the function of "Automatic Offset" described previously, the frame will move to the position (Offset Position) registered automatically at the free-setting point in the middle of sewing. The frame will move to the free-setting point after starting operation.

[Examples of use]

(1) Start the machine operation.

After starting the machine operation, the frame will move to the start position automatically.

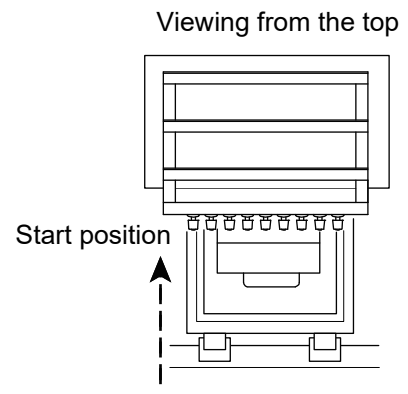

(2) The frame will move to the offset position automatically at the free-setting point in the middle of sewing.

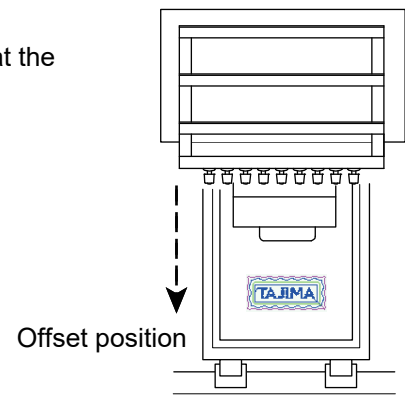

(3) Start the machine operation.

After starting the machine operation, the frame will move to the free-setting point, then the machine will restart sewing.

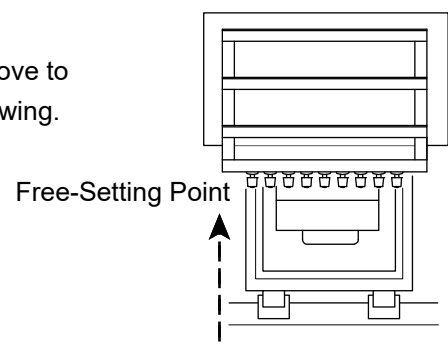

(4) The frame will move to the offset position automatically after completion of sewing.

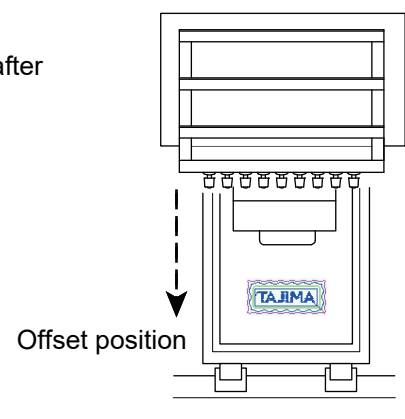

2-3. Auto Color Change Offset

In addition to the function of "Automatic Offset" described previously, the frame will move to the position (Offset Position) registered automatically at the color change point in the middle of sewing. The frame will move to the color change point after starting operation.

[Examples of use]

(1) Start the machine operation.

After starting the machine operation, the frame will move to the start position automatically.

Viewing from the top

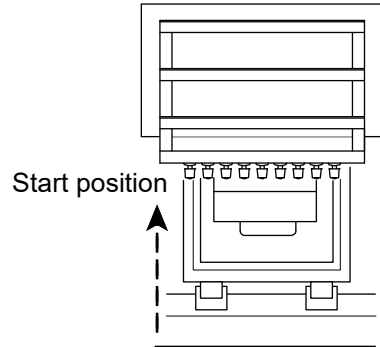

(2) The frame will move to the offset position automatically at the color change point in the middle of sewing.

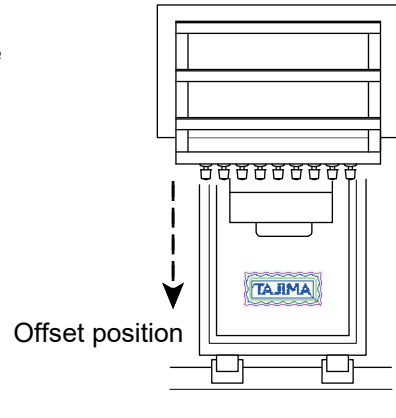

(3) Start the machine operation.

After starting the machine operation, the frame will move to the color change point automatically, then the machine will restart sewing.

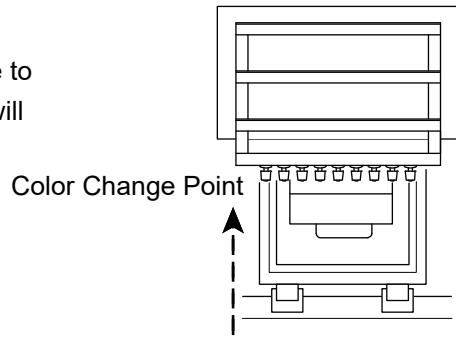

(4) The frame will move to the offset position automatically after completion of sewing.

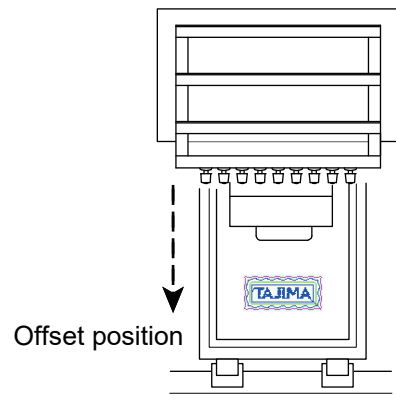

3. Trace

The frame will move along a periphery of the design from the start position.

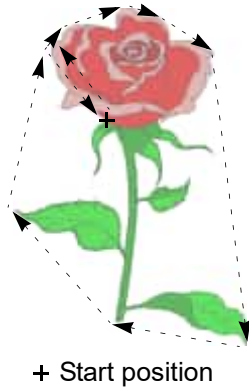

When automatic offset is set, the frame will move to → 1 Offset position → 2 Middle position → 3 Start position → 4 Periphery → 3 Start position → 2 Middle position → 1 Offset position (in the order).

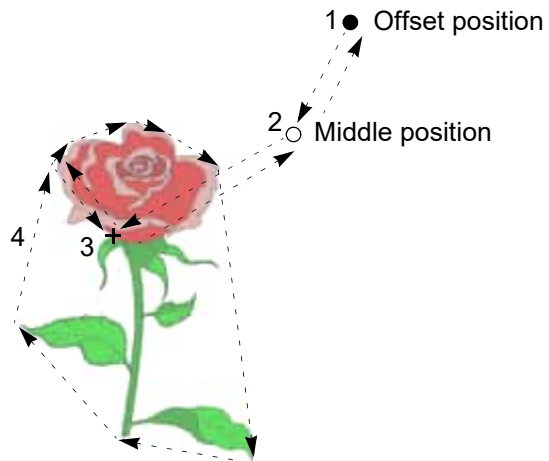

When repeat is set, the machine will trace the whole design after tracing the first design.

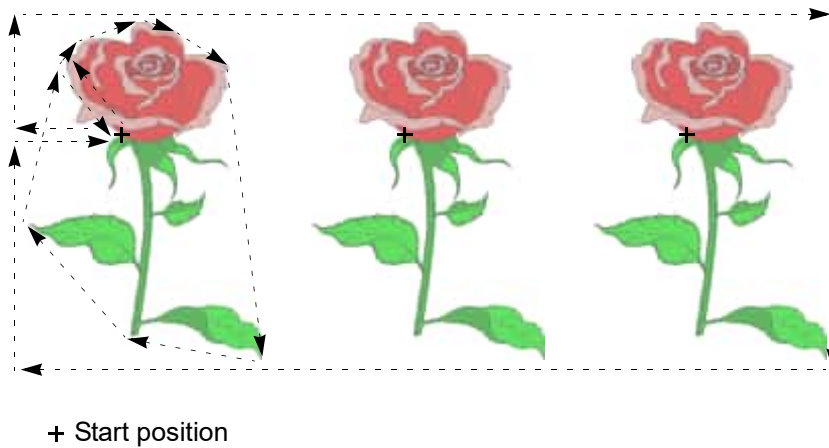

4. Head selection

Use this function when you want to select the working heads for each Needle Bar Step.

4-1. Head selecting screen (Screen 2010)

Set the pattern No. for the Needle Bar Step on this screen. The pattern No. will be displayed as P1 to P20, and it is possible to select the working heads for each pattern.

[How to switch the screen]

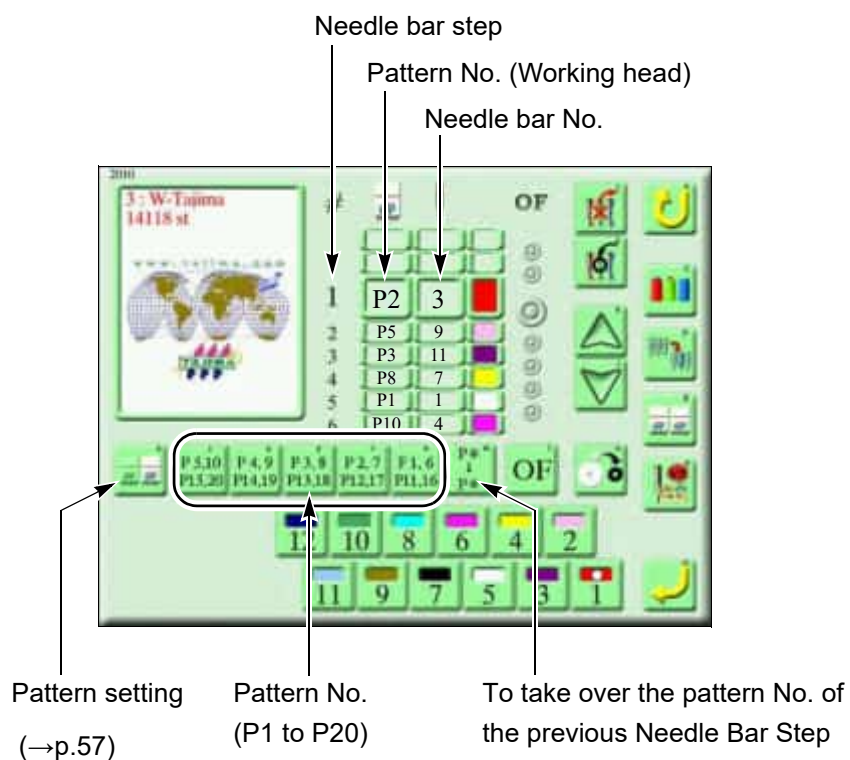
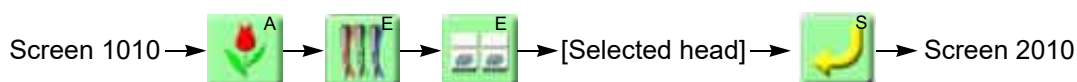

Sewing will be performed under the conditions of the chart below in the example above.

Needle bar step	Pattern No.	Needle bar No.
1	P2	3
2	P5	9
3	P3	11
4	P8	7
5	P1	1
6	P10	4

4-2. Pattern setting screen (Screen 2015)

Set the working head and the suspended head for each pattern from P1 to P20.

[How to switch the screen]

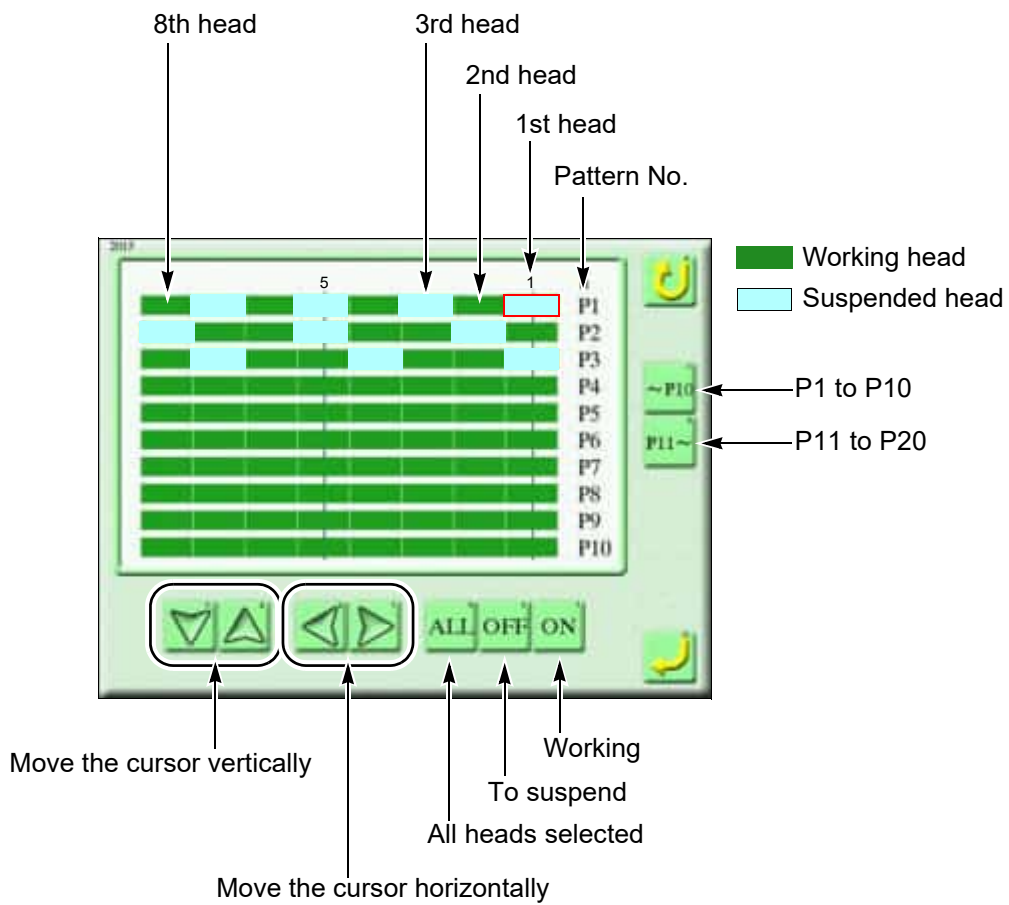

Heads in the chart below will work for each pattern No. in the example above.

Pattern No.	Working head
P1	2, 4, 6, 8
P2	1, 3, 4, 6, 7
P3	2, 3, 5, 6, 8
P4 and after	All heads

5. Return Stitches, Tie Stitches

5-1. V, Z, W

We explain about "V", "Z" and "W" displayed in the parameter "23. Return stitches/Condensation" or "24. Tie stitches/Condensation"

An example of Return Stitches

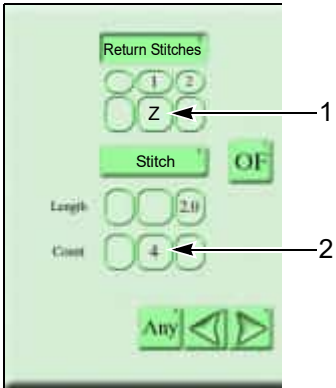

1. V: Number of setting stitches on a straight line

An example of 5-needle



Z: One reciprocation for the number of setting stitches on a straight line

An example of 5-needle

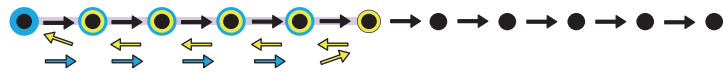

W: Two reciprocations for the number of setting stitches on a straight line

An example of 5-needle

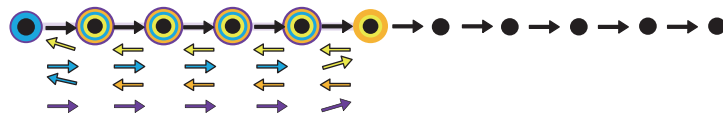

2. Number of stitches for Return Stitches or Tie Stitches

It is possible to set when V, Z and W are selected.



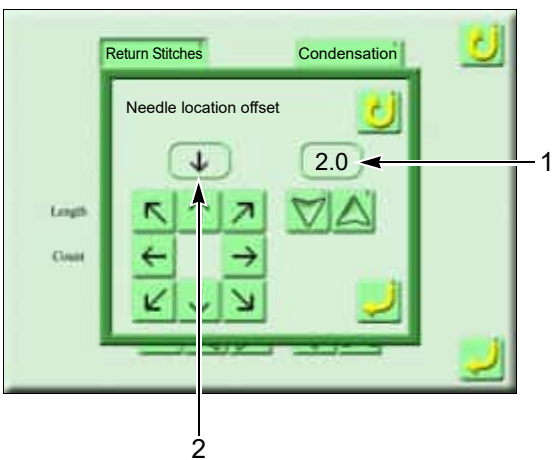

5-2. Needle location offset screen



1. Needle location offset value

In the example of the left figure, the needle location is displaced 2.0 mm against the original data.

2. Direction of needle location

-  The needle will locate at the rear.
-  The needle will locate at the front.
-  The needle will locate at the left.
-  The needle will locate at the right.

6. Condensation sewing

Condensation sewing means that Tie stitching is performed for several stitches with a small stitch length at start and end of sewing.

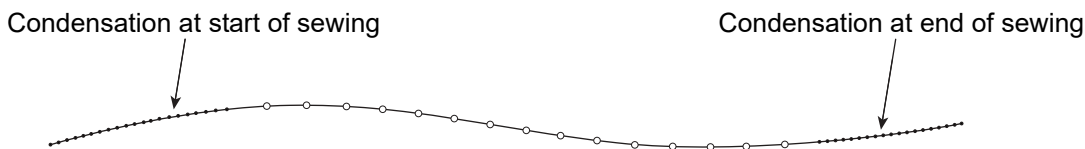

[Explanation of screen]

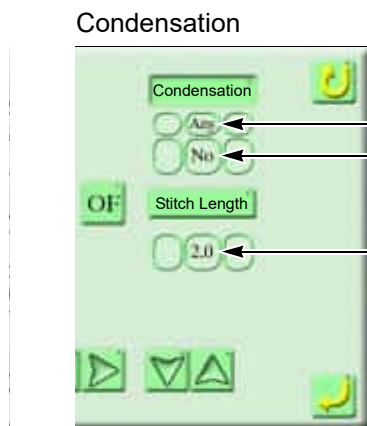

1. Any: All needles in a batch
1 to last needle: Needle bar unit
2. 1 to 9th needle: Condensation is performed.
No: Condensation is not performed.
3. 0.1 to 12.7: Stitch length

6-1. Condensation at start of sewing

Set Condensation at start of sewing in the parameter 23. "Return Stitches/Condensation".

(1) Setting example 1: Condensation → 3, Stitch length → 1.0

Condensation 3 means that 3rd stitch at first is subject to Condensation sewing in the original data.

Stitch length 1.0 means that the original stitch is divided into 1.0 mm or less equally.

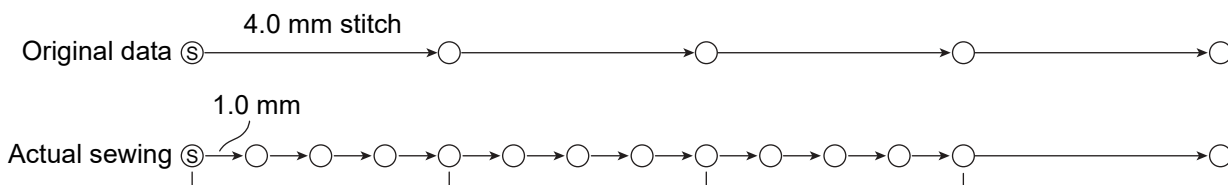

(2) Setting example 2: Condensation → 2, Stitch length → 3.0

Condensation 2 means that 2nd stitch at first is subject to Condensation sewing in the original data.

Stitch length 3.0 means that the original stitch is divided into 3.0 mm or less equally.

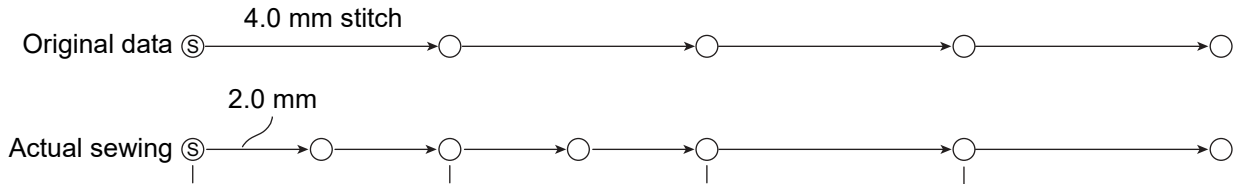

6-2. Condensation at end of sewing

Set Condensation at end of sewing in the parameter 24. "Tie Stitches/Condensation".

(1) Setting example 1: Condensation → 3, Stitch length → 1.5

Condensation 3 means that 3rd stitch at the end is subject to Condensation sewing in the original data.

Stitch length 1.5 means that the original stitch is divided into 1.5 mm or less equally.

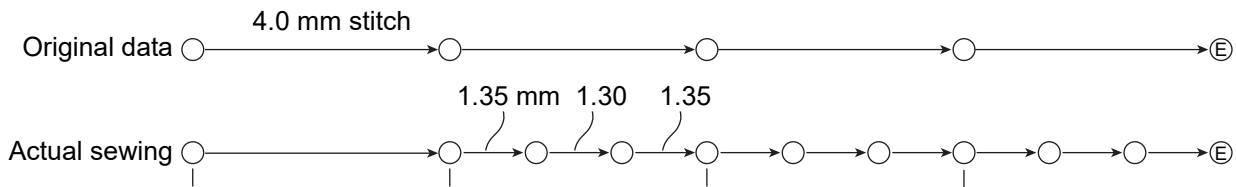

(2) Setting example 2: Condensation → 3, Stitch length → 4.0

Condensation 3 means that 3rd stitch at the end is subject to Condensation sewing in the original data.

Stitch length 4.0 means that the following three types of stitches are divided into 4.0 mm or less equally.

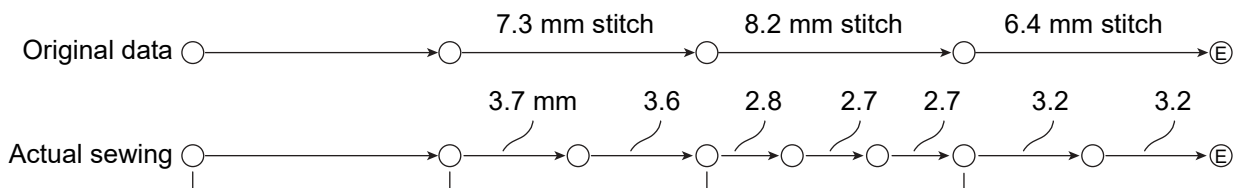

7. To create the design, to modify the design

This function can be used only for sewing design.

To use this function, set "Network" (P7-78-1) of parameter to "Sidekick [V2]". (→p.281)

7-1. Design creation function list

(1) Sewing selection screen

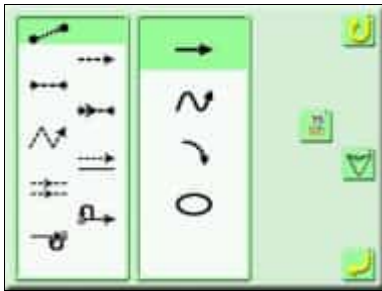







Icon	Sewing method	Icon	Sewing method
	Jump Feed		Straight Line
	Normal sewing		Spline
	Overlapped reverse sewing		Arc
	Overlapped sewing		Circle
	Zigzag sewing		
	Offset sewing		
	Multiple stitching		
	Return stitches		
	Tie stitches		

Basic sewing

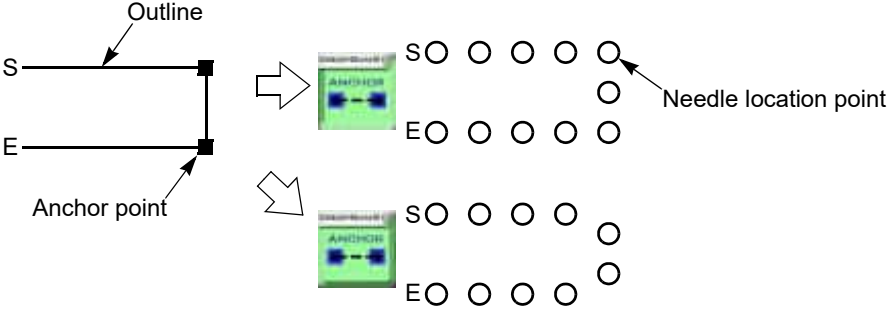



There are following five types of basic sewing.

1		[Regular intervals] Along the outline, generate stitches in regular intervals as possible by the setting stitch length or less.
2		[Maintaining stitch length] Maintain the setting stitch length. To adjust the stitch length to the outline length, change the length of the last stitch as required.
3		[Dividing stitch count] Along the outline, generate the number of set stitches in regular intervals as possible.

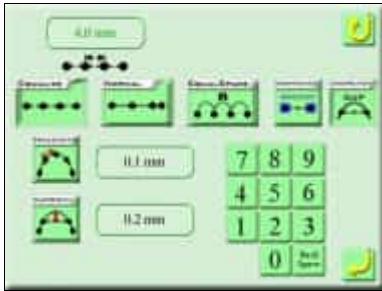
<p>4</p>		<p>[Anchor point]</p> <p>It is the fixed point to control the shape of design. The shape of design can be changed by changing the location of this anchor point. It is possible to register by "Point" key, and also possible to perform Addition/Move/Deletion by the modification of configuration point.</p> <p> The needle is always lowered to the anchor point. Therefore, the created design will be almost in the same shape of the outline. Form stitches of "Setting stitch length" or less between anchor points. For the stitch length, follow the setting of "Regular interval" or "Maintaining stitch length".</p> <p> There is the case that the needle is not lowered to the anchor point. In that case, the created design may be slightly different from the outline. Regardless of the anchor point, form stitches by "Setting stitch length" or less. For the stitch length, follow the setting of "Regular interval" or "Maintaining stitch length".</p> <p>Example</p> 
<p>5</p>		<p>[Curved line gap]</p> <p>Place stitches by shortening the stitch length in the upper part of the curved line (R part) so as to fit smoothly to the curved line of the outline.</p> <p>The curved line gap cannot be used for "Maintaining stitch length".</p> <p>"Curved line gap" and "Anchor point Yes" cannot be used at the same time.</p> <p> Minimum stitch length Set "Lower limit value of stitch length" of the portion where the curved line gap is applied.</p> <p> Maximum gap width of curved line Set the acceptable maximum width between "The curved line of the outline" and the width of "Stitches sewn actually" (the length of the red arrow).</p>

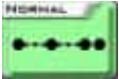
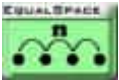





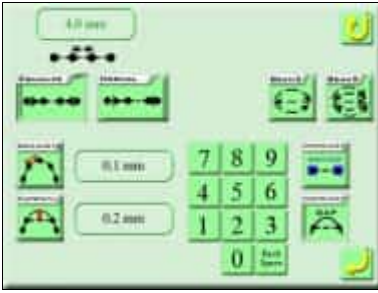

(2) Normal sewing setting screen (---->)

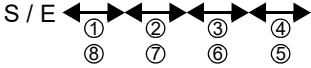

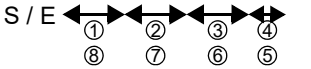
Icon	Generated sewing
	<p>[Normal sewing / Regular intervals]</p> <p>Generate a straight line of stitches on the outline. Make regular intervals as possible by the setting stitch length or less.</p> <p>Example: Setting stitch length = 3.0 mm, Straight line design of 10 mm length. In that case, generated stitches are 2.5 mm x 4 stitches.</p> <p style="text-align: center;">S → ① → ② → ③ → ④ → E</p>
	<p>[Normal sewing / Maintaining stitch length]</p> <p>Generate a straight line of stitches on the outline. Maintain the setting stitch length.</p> <p>Example: Setting stitch length = 3.0 mm, Straight line design of 10 mm length. In that case, generated stitches are 3.0 mm x 3 stitches + 1.0 mm x 1 stitch.</p> <p style="text-align: center;">S → ① → ② → ③ → ④ → E</p>
	<p>[Normal sewing / Dividing stitch count]</p> <p>Generate a straight line of stitches on the outline. Divide intervals equally as possible by the setting stitch length.</p> <p>Example: Setting value = 3, Straight line design of 150 mm length. In that case, generated stitches are non-data St + 50.0 mm St (Jp + Jp.. + St) x 3.</p> <p style="text-align: center;">S → ① → ② → ③ → E</p>
	<p>Refer to "Anchor point". (→p.62)</p>
  	<p>Refer to "Curved line gap". (→p.62)</p>

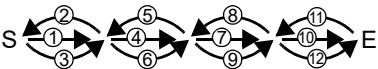
(3) Overlapped reverse sewing setting screen ()

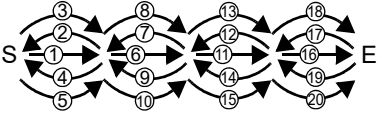









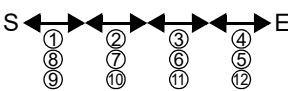

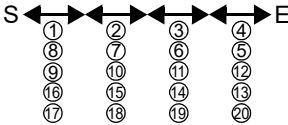
Icon	Generated sewing
	<p>[Overlapped reverse sewing in regular intervals]</p> <p>Generate stitches of 1 repeat (go→return) on the whole outline. Make regular intervals as possible by the setting stitch length or less.</p> <p>Example: Setting stitch length = 3.0 mm, Straight line design of 10 mm length. In that case, the generated stitches are "2.5 mm x 4 stitches" + "2.5 mm to 180 degrees opposite direction x 4 stitches".</p> <p>S / E </p>
	<p>[Overlapped reverse sewing / Maintaining stitch length]</p> <p>Generate stitches of 1 repeat (go→return) on the whole outline. Maintain the setting stitch length.</p> <p>Example: Setting stitch length = 3.0 mm, Straight line design of 10 mm length. In that case, generated stitches are "3.0 mm x 3 stitches + 1.0 mm x 1 stitch" + "1.0 mm to 180 degrees opposite direction x 1 stitch + 3.0 mm x 3 stitches".</p> <p>S / E </p>
	<p>[Overlapped reverse sewing in regular intervals + Bean 3 times]</p> <p>Generate stitches of 1.5 repeat sewing (go→return→go) for 1 stitch on the outline. Make regular intervals as possible by the setting stitch length or less.</p> <p>Example: Setting stitch length = 3.0 mm, Straight line design of 10 mm length. In that case, generated stitches are "2.5 mm + (2.5 mm to 180 degrees opposite direction) + 2.5 mm" x 4.</p> <p>S  E</p>
	<p>[Overlapped reverse sewing in regular intervals + Bean 5 times]</p> <p>Generate stitches of 2.5 repeat sewing (go→return→go→return→go) for 1 stitch on the outline. Make regular intervals as possible by the setting stitch length or less.</p> <p>Example: Setting stitch length = 3.0 mm, Straight line design of 10 mm length. In that case, generated stitches are "2.5 mm + (2.5 mm to 180 degrees opposite direction) + 2.5 mm + (2.5 mm to 180 degrees opposite direction) + 2.5 mm" x 4.</p> <p>S  E</p>
	<p>Refer to "Anchor point". (→p.62)</p>

	<p>Refer to "Curved line gap". (→p.62)</p>
---	--

(4) Overlapped sewing setting screen (➡➡←←)







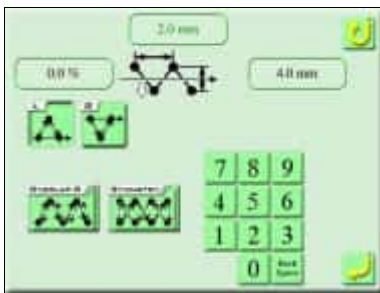

Icon	Generated sewing
	<p>[Overlapped sewing / 3 times]</p> <p>Generate stitches of 1.5 repeat sewing (go→return→go) on the whole outline. For the stitch length, follow "Regular intervals" or "Maintaining stitch length".</p> <p>Example: Setting stitch length = 3.0 mm, Straight line design in regular intervals of 10 mm length. In that case, generated stitches are "2.5 mm x 4 stitches" + "2.5 mm to 180 degrees opposite direction x 4 stitches" + "2.5 mm x 4 stitches".</p> <div style="text-align: center;">  </div>
	<p>[Overlapped sewing / 5 times]</p> <p>Generate stitches of 2.5 repeat sewing (go→return→go→return→go) on the whole outline. For the stitch length, follow "Regular intervals" or "Maintaining stitch length".</p> <p>Example: Setting stitch length = 3.0 mm, Straight line design in regular intervals of 10 mm length. In that case, generated stitches are "2.5 mm x 4 stitches" + "2.5 mm to 180 degrees opposite direction x 4 stitches" + "2.5 mm x 4 stitches" + "2.5 mm to 180 degrees opposite direction x 4 stitches" + "2.5 mm x 4 stitches".</p> <div style="text-align: center;">  </div>
	<p>[Offset of Repeat]</p> <p>To prevent the stitch lowering to the same needle location point, shift the needle location point of the straight line stitches of repeat.</p>
	<p>Refer to "Maintaining stitch length". (→p.61)</p>

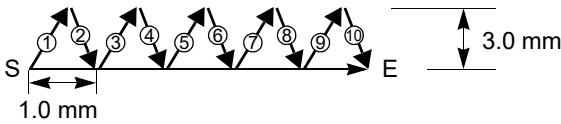
	Refer to "Regular intervals". (→p.61)
	Refer to "Anchor point". (→p.62)
  	Refer to "Curved line gap". (→p.62)

(5) Zigzag sewing setting screen ()

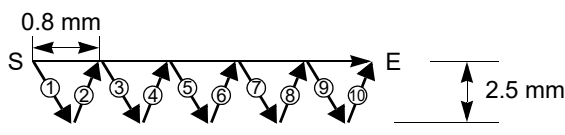

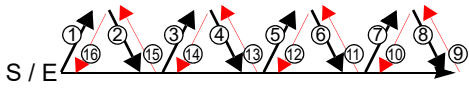

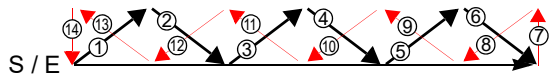



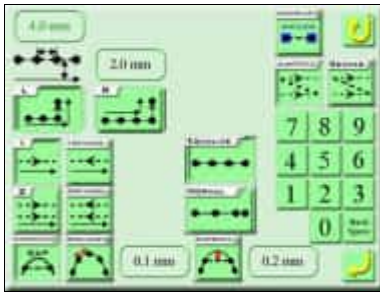

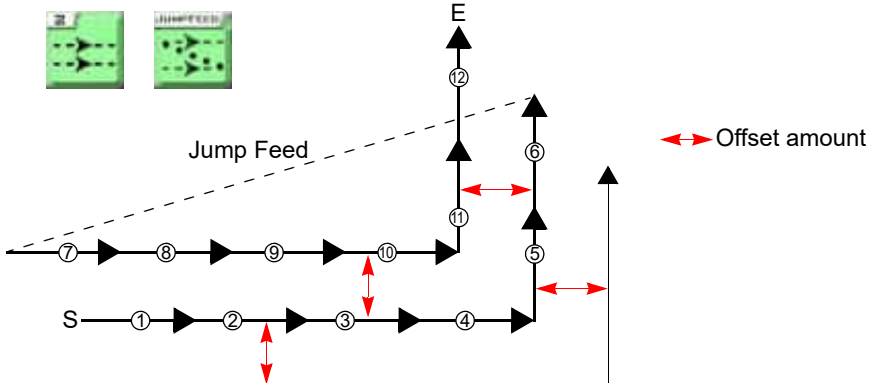



















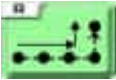
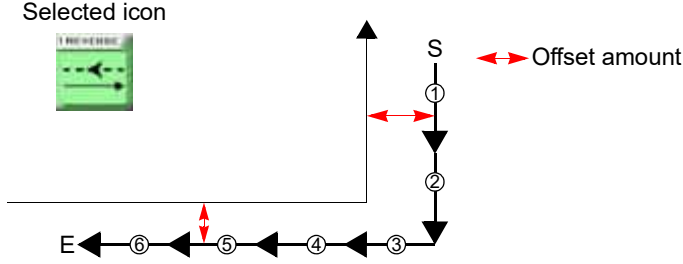











Icon	Generated sewing
	<p>[Zigzag sewing Zigzag L]</p> <p>Along the outline, generate zigzag stitches by the setting width and pitch. "L" generates stitches at the left side of the moving direction of the outline.</p> <p>Example: The outline is 5 mm straight line.</p> <p>Setting width: 3.0 mm,</p> <p>Pitch: 1.0 mm</p> <p>Generated stitches are as shown in the figure below.</p> 

	<p>[Zigzag sewing Zigzag R]</p> <p>Along the outline, generate zigzag stitches by the setting width and pitch. "R" generates stitches at the right side of the moving direction of the outline.</p> <p>Example: The outline is 4 mm straight line.</p> <p>Setting width: 2.5 mm,</p> <p>Pitch: 0.8 mm</p> <p>Generated stitches are as shown in the figure below.</p> 
	<p>[Overlapped reverse sewing]</p> <p>Perform Zigzag sewing of "One repeat at the same track". Select the sewing method from the above 2 patterns.</p> <p>Example: If the original sewing method is "Zigzag sewing Zigzag L"</p> <p>→ Advancing stitch ← Returning stitch</p> 
	<p>[Symmetrical sewing]</p> <p>Perform Zigzag sewing of "Reverse sewing at the symmetrical track". Select the sewing method from the above 2 patterns. Example: If the original sewing method is "Zigzag sewing Zigzag L"</p> <p>→ Advancing stitch ← Returning stitch</p> 

(6) Offset sewing ()









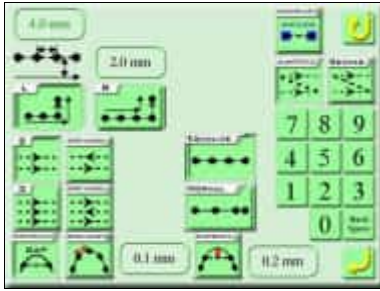

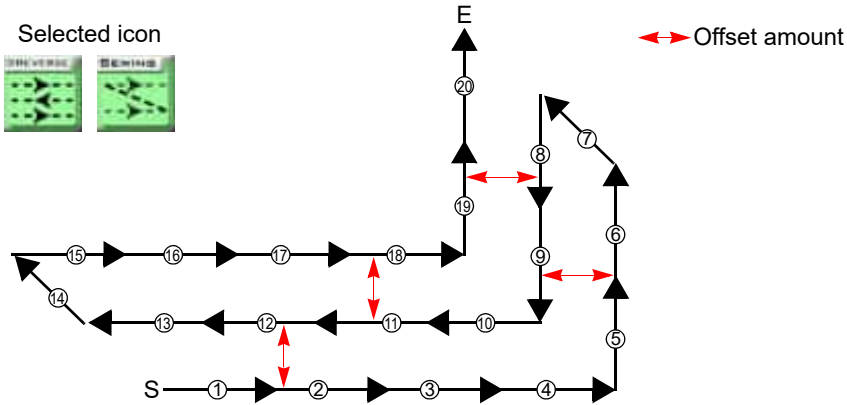





















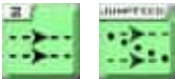
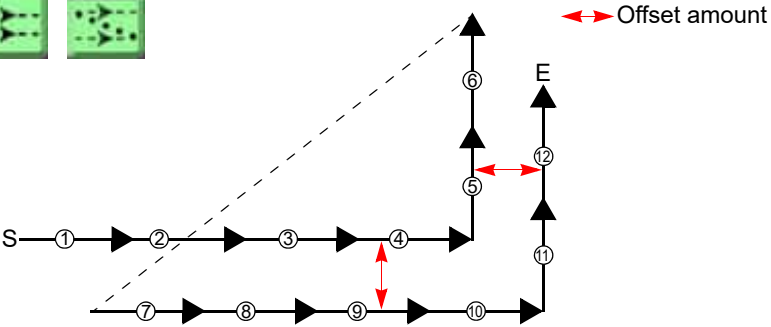













Icon	Generated sewing												
	<p>[Offset sewing L] Along the outline, generate stitches at the position away for the setting distance (offset amount) in vertical direction (to create a line of stitches in regular intervals). Stitches are not generated on the outline. The sewing direction can be specified to the direction of the outline. "L" generates stitches at the left side of the moving direction of the outline. Example: Number of overlapped times = 3, Sewing direction = Reverse/Forward, Design interval = Jump Feed</p> <p>Selected icon</p>  <table border="1" data-bbox="304 1417 987 1736"> <tbody> <tr> <td></td> <td>Forward</td> <td></td> <td>Reverse</td> </tr> <tr> <td></td> <td>Forward/ Forward</td> <td></td> <td>Reverse/ Reverse</td> </tr> <tr> <td></td> <td>Jump Feed^[1]</td> <td></td> <td>Stitch^[2]</td> </tr> </tbody> </table> <p>[1] The space between lines is not sewn. [2] The space between lines is sewn.</p>		Forward		Reverse		Forward/ Forward		Reverse/ Reverse		Jump Feed ^[1]		Stitch ^[2]
	Forward		Reverse										
	Forward/ Forward		Reverse/ Reverse										
	Jump Feed ^[1]		Stitch ^[2]										

	<p>[Offset sewing R]</p> <p>Along the outline, generate stitches at the position away for the setting distance (offset amount) in vertical direction (to create a line of stitches in regular intervals). Stitches are not generated on the outline. The sewing direction can be specified to the direction of the outline.</p> <p>"R" generates stitches at the right side of the moving direction of the outline.</p> <p>Example: Number of overlapped times = 2, Sewing direction = Reverse</p> <div style="text-align: center;">  </div> <table border="1" data-bbox="416 790 1102 1111"> <tr> <td></td> <td>Forward</td> <td></td> <td>Reverse</td> </tr> <tr> <td></td> <td>Forward/ Forward</td> <td></td> <td>Reverse/ Reverse</td> </tr> <tr> <td></td> <td>Jump Feed^[1]</td> <td></td> <td>Stitch^[2]</td> </tr> </table> <p>[1] The space between lines is not sewn. [2] The space between lines is sewn.</p>		Forward		Reverse		Forward/ Forward		Reverse/ Reverse		Jump Feed ^[1]		Stitch ^[2]
	Forward		Reverse										
	Forward/ Forward		Reverse/ Reverse										
	Jump Feed ^[1]		Stitch ^[2]										
	<p>Refer to "Regular intervals". (→p.61)</p>												
	<p>Refer to "Maintaining stitch length". (→p.61)</p>												
	<p>Refer to "Anchor point". (→p.62)</p>												
	<p>Refer to "Curved line gap". (→p.62)</p>												

(7) Multiple stitching ()







Icon	Generated sewing												
	<p data-bbox="279 719 496 748">[Multiple stitching L]</p> <p data-bbox="279 757 1370 875">Along the outline, generate stitches at the position away for the setting distance (offset amount) in vertical direction. Stitches are also generated on the the outline. The sewing direction can be specified to the direction of the outline. "L" generates stitches at the left side of the moving direction of the outline.</p> <p data-bbox="279 887 1142 947">Example: Number of overlapped times = 3, Sewing direction = Reverse/Forward, Design interval = Stitch</p> <div data-bbox="368 1003 1219 1406">  </div> <table border="1" data-bbox="304 1451 987 1771"> <tbody> <tr> <td></td> <td>Forward</td> <td></td> <td>Reverse</td> </tr> <tr> <td></td> <td>Forward/ Forward</td> <td></td> <td>Reverse/ Forward</td> </tr> <tr> <td></td> <td>Jump Feed^[1]</td> <td></td> <td>Stitch^[2]</td> </tr> </tbody> </table> <p data-bbox="352 1787 791 1816">[1] The space between lines is not sewn.</p> <p data-bbox="352 1827 751 1856">[2] The space between lines is sewn.</p>		Forward		Reverse		Forward/ Forward		Reverse/ Forward		Jump Feed ^[1]		Stitch ^[2]
	Forward		Reverse										
	Forward/ Forward		Reverse/ Forward										
	Jump Feed ^[1]		Stitch ^[2]										

	<p>[Multiple stitching R] Along the outline, generate stitches at the position away for the setting distance (offset amount) in vertical direction. Stitches are also generated on the the outline. The sewing direction can be specified to the direction of the outline. "R" generates stitches at the right side of the moving direction of the out line. Example: Number of overlapped times = 2, Sewing direction = Forward, Design interval = Jump Feed</p> <p>Selected icon</p>   <table border="1" data-bbox="416 887 1147 1207"> <tr> <td></td> <td>Forward</td> <td></td> <td>Reverse</td> </tr> <tr> <td></td> <td>Forward/Forward</td> <td></td> <td>Reverse/Forward</td> </tr> <tr> <td></td> <td>Jump Feed^[1]</td> <td></td> <td>Stitch^[2]</td> </tr> </table> <p>[1] The space between lines is not sewn. [2] The space between lines is sewn.</p>		Forward		Reverse		Forward/Forward		Reverse/Forward		Jump Feed ^[1]		Stitch ^[2]
	Forward		Reverse										
	Forward/Forward		Reverse/Forward										
	Jump Feed ^[1]		Stitch ^[2]										
	<p>Refer to "Regular intervals". (→p.61)</p>												
	<p>Refer to "Maintaining stitch length". (→p.61)</p>												
	<p>Refer to "Anchor point". (→p.62)</p>												
  	<p>Refer to "Curved line gap". (→p.62)</p>												





(8) Return stitches ()



Icon	Generated sewing
	[Return stitches (V)] At start of sewing, return stitching is performed for number of setting stitches on the straight line. (→ p.58)
	[Return stitches (Z)] At start of sewing, 1 repeat of return stitching is performed for number of setting stitches on the straight line. (→p.58)
	[Return stitches (W)] At start of sewing, 2 repeats of return stitches are performed for number of setting stitches on the straight line. (→p.58)
	[Condensation of start sewing] Tie stitching is performed for several stitches with a small stitch length at start of sewing. (→p.59)







(9) Tie stitches ()





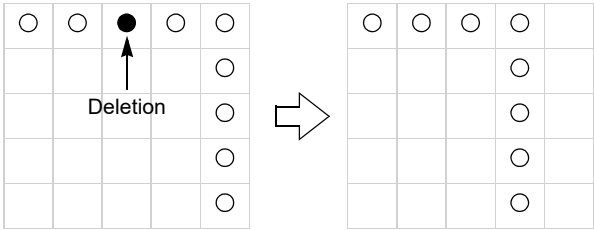

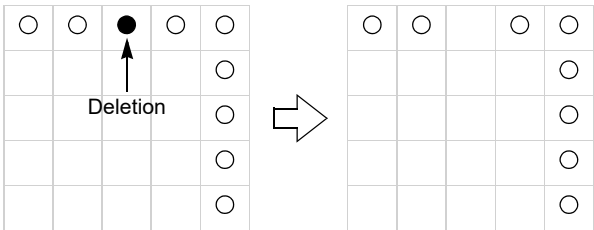



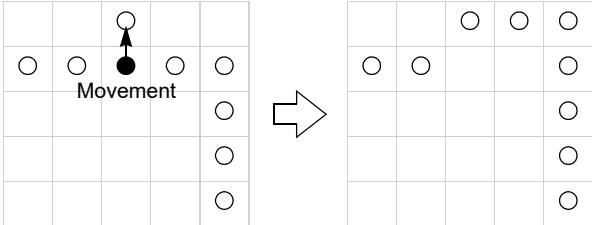

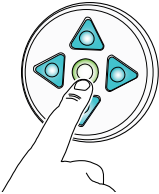

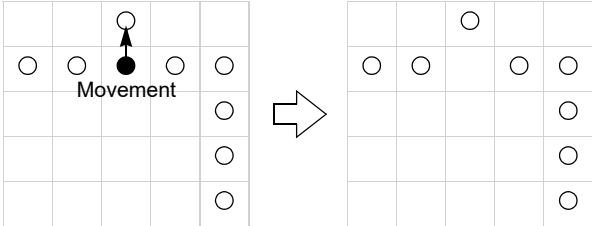

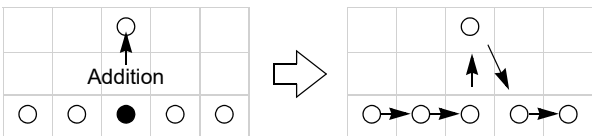

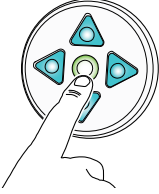

Icon	Generated sewing
	[Tie stitches (V)] At end of sewing, tie stitching is performed for number of setting stitches on the straight line. (→p.58)
	[Tie stitches (Z)] At end of sewing, 1 repeat of tie stitching is performed for number of setting stitches on the straight line. (→p.58)
	[Tie stitches (W)] At end of sewing, 2 repeats of tie stitching are performed for number of setting stitches on the straight line. (→p.58)
	[Condensation of end sewing] Tie stitching is performed for several stitches with a small stitch length at end of sewing. (→p.60)

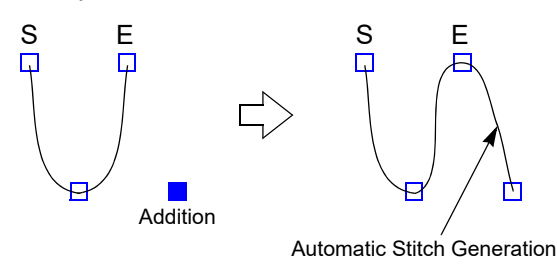
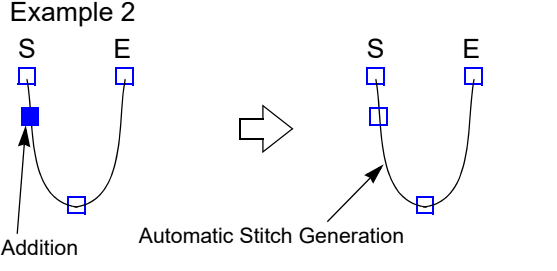

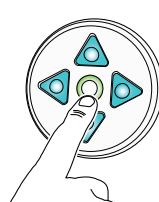
7-2. Design modification function list

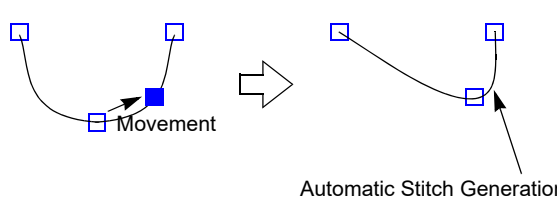
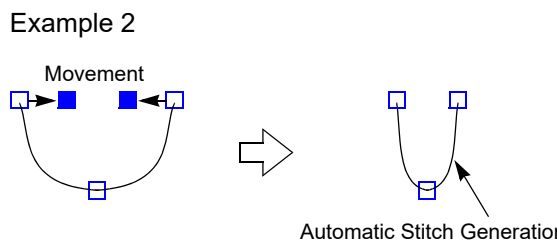

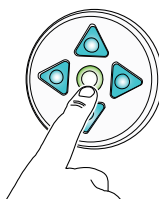
If "Point Deletion Relative", "Point Movement Relative", "Linear Apex Deletion Relative" and "Linear Apex Movement Relative" are executed, the point after that selected will move.



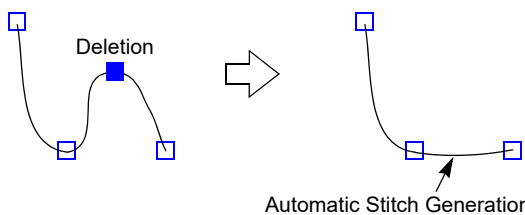

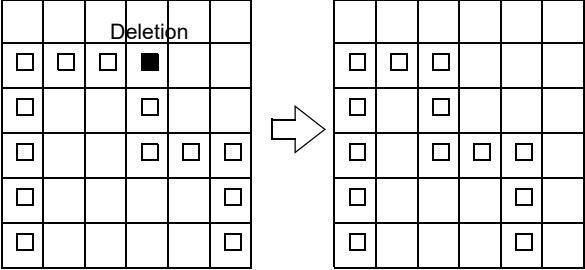
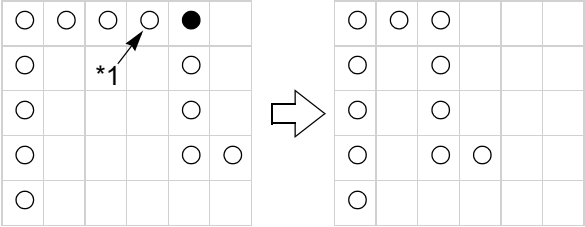

Name	Details	How to operate
Change of sewing setting	Sewing method in the specified section is changed. (→p.63)	—
Element Deletion	Delete the element in unit of element.	<p>(1) Move to the point in targeted element by FF or FB.</p>  <p>Perform setting.</p> 
Pattern Deletion	Delete all points of the design during edition.	<p>Perform setting.</p> 
Point Deletion Relative	<p>The data of after deleted point will move.</p> <p>Delible range: One to all stitches</p> 	<p>(1) Move to the point to delete by FF or FB.</p>  <p>(2) Perform setting.</p> 
Point Deletion Absolute	<p>The data of after deleted point will not move. One stitch will be deleted without changing the shape of the design.</p> <p>Delible range:</p> <p>Number of stitches from 1st stitch to the stitch where the interval after deletion is 12.7 mm</p> 	<p>(1) Move to the point to delete by FF or FB.</p>  <p>(2) Perform setting.</p> 

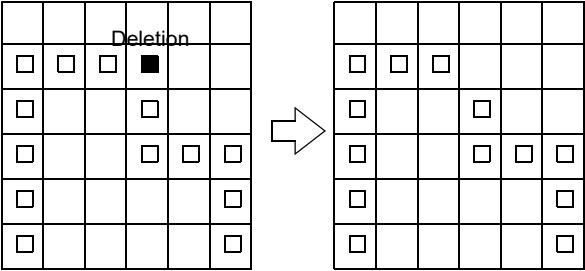

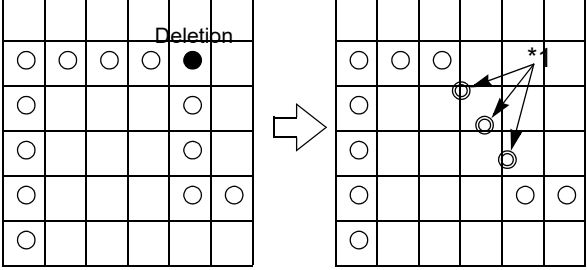

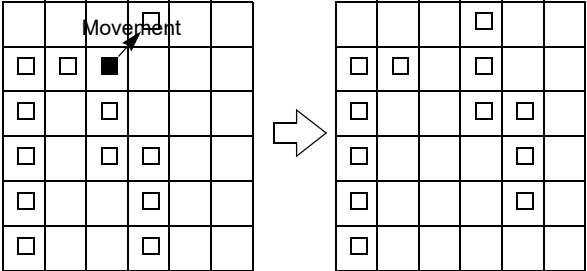
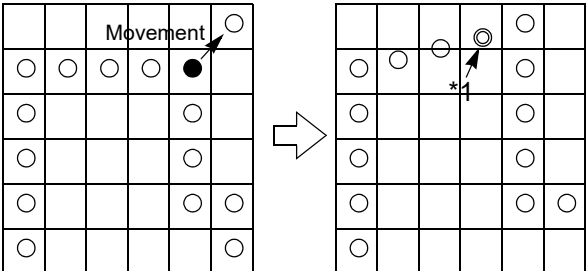
Name	Details	How to operate
Point Movement Relative	<p>The data of the point after that moved will move.</p> <p>Movable range: Position where the interval after movement is up to 12.7 mm</p> 	<p>(1) Move to the point to travel by FF or FB.</p>  <p>(2) Perform the frame travel to the position after moving by pressing the frame travel key.</p>  <p>(3) Perform setting.</p> 
Point Movement Absolute	<p>The data of the point after that moved will not move.</p> <p>Movable range: Position where the interval after movement is up to 12.7 mm</p> 	<p>(3) Perform setting.</p> 
Point Addition Absolute	<p>Add the point at the rear of the specified needle location. The data of the point after that deleted will not move.</p> <p>Movable range: Position where the interval after movement is up to 12.7 mm</p> 	<p>(1) Move the frame to the place before the point to add by FF or FB.</p>  <p>(2) Perform the frame travel to the position to add by pressing the frame travel key.</p>  <p>(3) Perform setting.</p> 

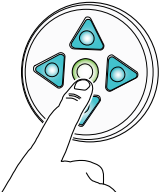
Name	Details	How to operate
<p>Configuration Point Addition</p>	<p>Add the configuration point at the rear of the specified configuration point.</p> <p>Addable range: Whole area of design</p> <p>Example 1</p>  <p>Example 2</p> 	<p>(1) Move the frame to the place before the point to add by FF or FB.</p>  <p>(2) Perform the frame travel to the position to add by pressing the frame travel key.</p>  <p>(3) Perform setting.</p> 
<p>Configuration Point Move</p>	<p>Move the configuration point</p> <p>Movable range: Whole area of design</p> <p>Example 1</p>  <p>Example 2</p> 	<p>(1) Move to the point to travel by FF or FB.</p>  <p>(2) Perform the frame travel to the position after moving by pressing the frame travel key.</p>  <p>(3) Perform setting.</p> 

Name	Details	How to operate
<p>Configuration Point Deletion</p>	<p>Delete the configuration point. Delible range: Whole area of design</p> 	<p>(1) Move to the point to delete by FF or FB.</p>  <p>(2) Perform setting.</p> 

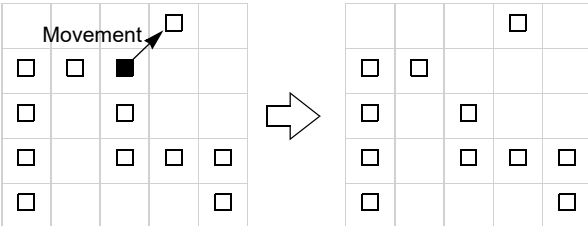
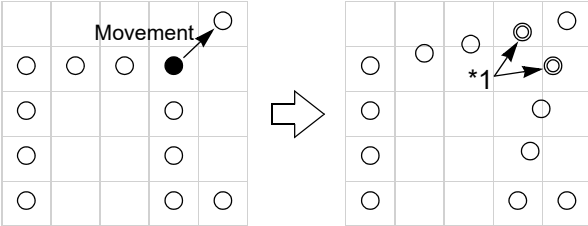
Name	Details	How to operate
<p>Linear Apex Deletion Relative</p> <p>[Apex]</p> <p>The position equal to the corner of the polygon like a square is called "Apex", and Apex has dedicated design edit function.</p>	<p>The data of after deleted point will move.</p> <p>[In case of configuration point]</p> <p>Delible range: Apex</p>  <p>[In case of stitch point]</p> <p>Delible range: Apex</p>  <p>*1: The data before apex to be deleted will also disappear.</p>	<p>(1) Move to the apex to delete by FF or FB.</p>  <p>(2) Perform setting.</p> 
<p>Linear Apex Deletion Absolute</p>	<p>The data of after deleted point will not move and the design will be created automatically as shown in the figure A.</p> <p>[In case of configuration point]</p> <p>Delible range: Apex</p> <p>Figure A</p> 	

Name	Details	How to operate
<p>Linear Apex Deletion Absolute</p>	<p>[In case of stitch point] Deleible range: Apex</p> <p style="text-align: center;">Figure A</p>  <p>*1: The data created automatically</p>	<p>(1) Move to the apex to delete by FF or FB.</p>  <p>(2) Perform setting.</p> 
<p>Linear Apex Movement Relative</p>	<p>The data of the point after that moved will move.</p> <p>[In case of configuration point] Movable range: Within the frame embroidery space</p>  <p>[In case of stitch point] Movable range: Within the frame embroidery space</p>  <p>*1: The data created automatically</p>	<p>(1) Move to the apex to travel by FF or FB.</p>  <p>(2) Perform the frame travel to the position after moving by pressing the frame travel key.</p>  <p>(3) Perform setting.</p> 

Name	Details	How to operate
<p>Linear Apex Movement Absolute</p>	<p>The data of the point after that moved will not move.</p> <p>[In case of configuration point]</p> <p>Movable range: Within the frame embroidery space</p>  <p>[In case of stitch point]</p> <p>Movable range: Within the frame embroidery space</p>  <p>*1: The data created automatically</p>	<p>(1) Move to the apex to travel by FF or FB.</p>  <p>(2) Perform the frame travel to the position after moving by pressing the frame travel key.</p>  <p>(3) Perform setting.</p> 



Chapter 5

Sewing procedure

1. Turn ON the power	82
2. Preparation	83
3. To input design to machine memory	91
4. To decide design to stitch (Data set)	97
5. To decide sewing mode	99
6. Items to check	101
7. To move frame to start position	103
8. Trace	104
9. To start sewing.....	106

1. Turn ON the power

CAUTION

-  Do not turn ON the machine power with the USB memory connected to the operation panel. The system sometimes may not start up.
-  When performing this operation, do not put your hands, etc. on the table. Moving the frame could injure you.

When the power starts up, after the screen of software version displays, the main screen will appear. From this screen, setting or operation will be started.

Screen of software version

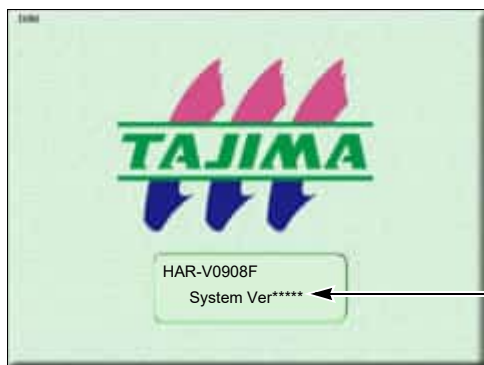



Software version of panel card

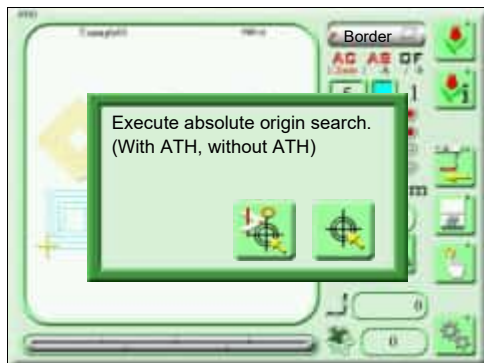

Main screen



The message shown left will be displayed only when "Absolute origin search at power ON" is set to Yes. (→ p.272)

-  Frame travel will be performed after thread trimming. (Execute absolute origin search)
-  Frame travel will be performed without thread trimming. (Execute absolute origin search)

If some trouble occurs during stitching the sewing design with the setting of "Absolute origin search at power ON" as "Yes" or if you do not want to display this message, set the parameter described above to "No".

2. Preparation

2-1. To set fabric

The type of clip and its clipping method differ depending on the shape of the border frame sash. (Figure A, B)

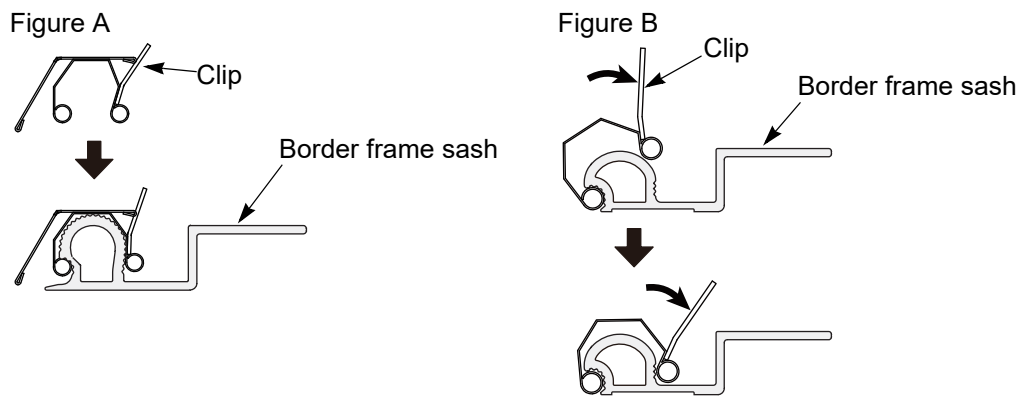

The photo below is an example when fixing the fabric to the border frame sash by using the placement sewing sheet.

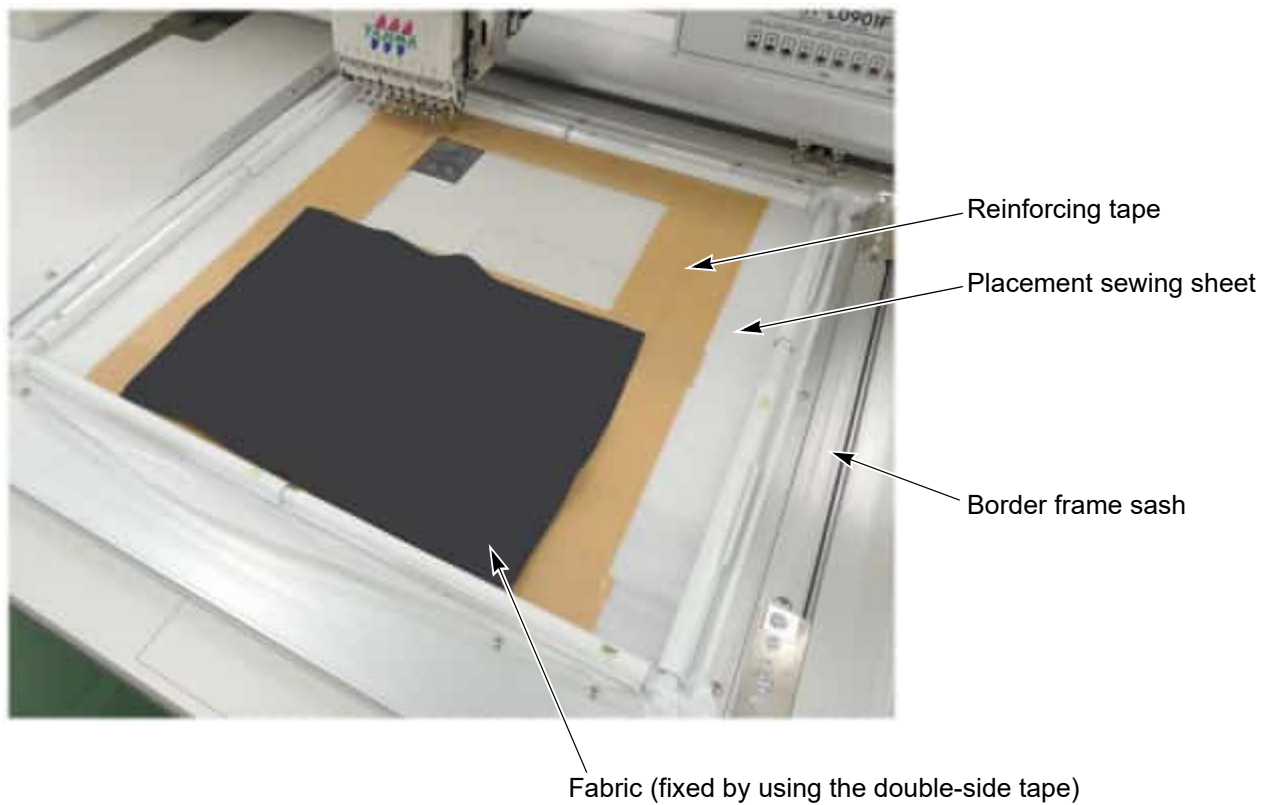

2-2. To attach snarl-preventive parts

Attach snarl-preventive parts (accessory) before threading.



Snarl-preventive parts

This is the part to prevent thread from snarl or loosing at thread cone.

[Snarl-preventive parts]

Quantity	Part No.	Part name
30 sets	911400100T00	SNARL-PREVENTIVE PART :30 SET[T]
10 sets	911400200T00	SNARL-PREVENTIVE PART :10 SET[T]

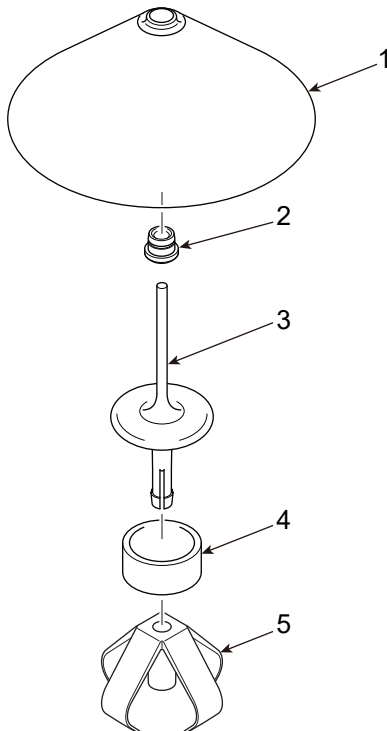

Num ber	Part No.	Part name
1	0D0110520000	CAP :SNARL-PREVENTIVE
2	516501010010	THREAD GUIDE COLLAR :WHITE :4.5MM DIA.
3	0D0110540000	GUIDE :SNARL-PREVENTIVE
4	0D0110550000	COLLAR :SNARL-PREVENTIVE
5	0D0110530000	HOLDER :SNARL-PREVENTIVE

[How to assemble]

(1) Attach the guide passing through the collar to the holder.

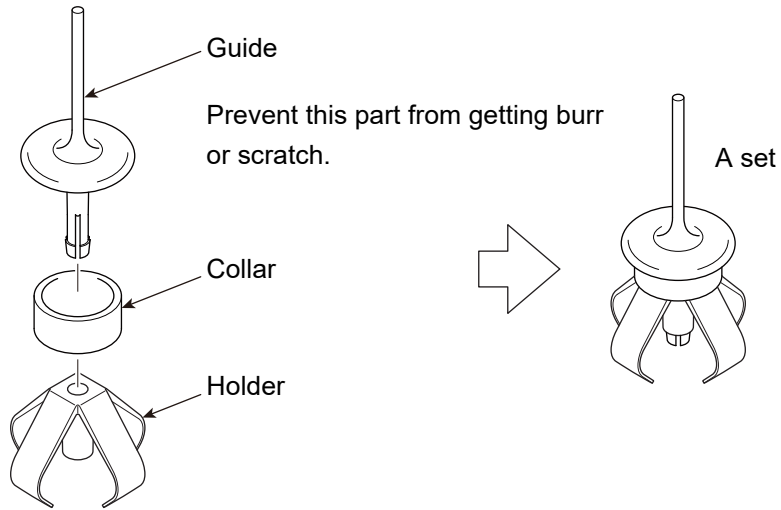

(2) Attach the thread guide collar inside the cap.

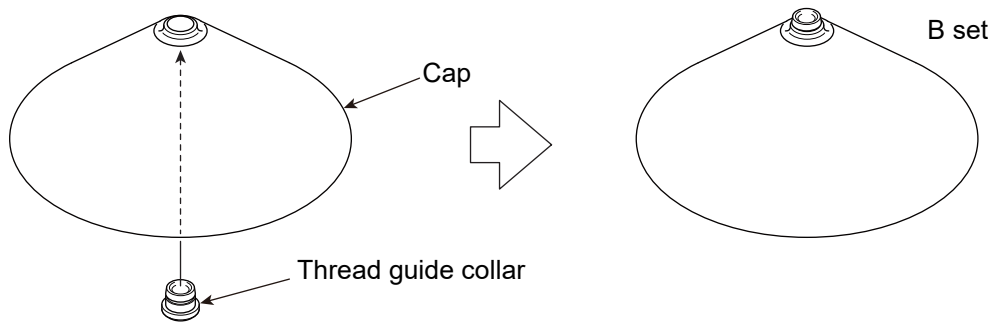

[How to use]

(1) When the hole diameter at the upper part of the thread cone is 17 mm or more:

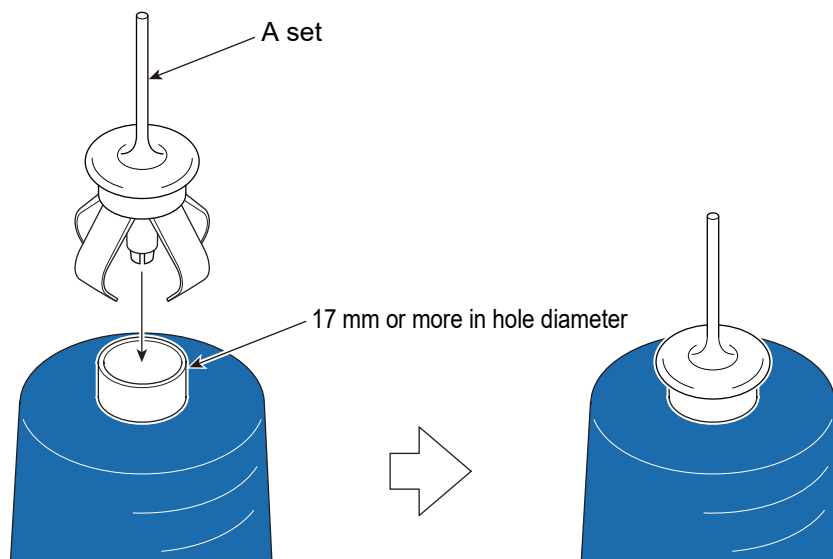

(2) When the hole diameter at the upper part of the thread cone is less than 17 mm:

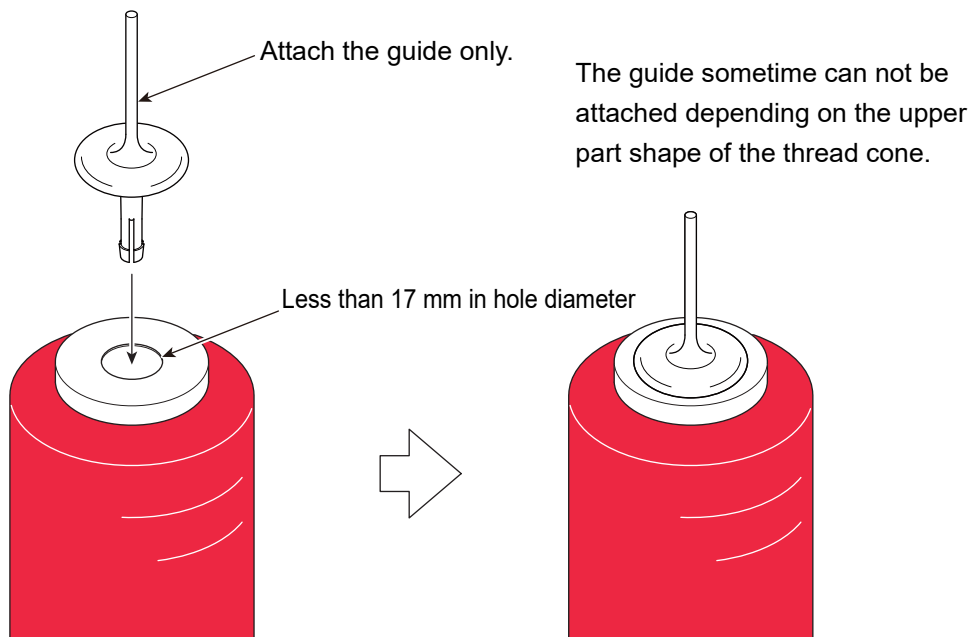

(3) Put B set on the guide.

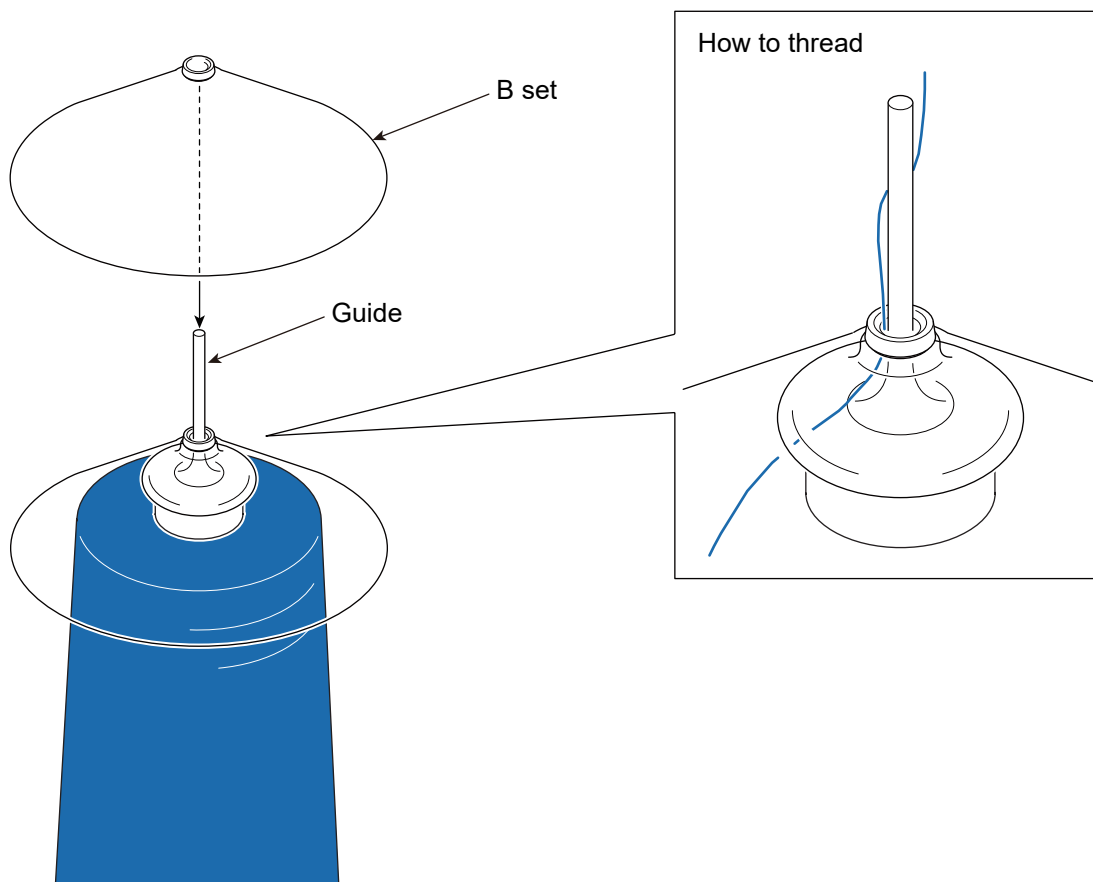

(4) When the height of thread cones next to each other are the same, B sets interfere with each other. Therefore, add to put the felt under either one thread cone as shown in the photo below.

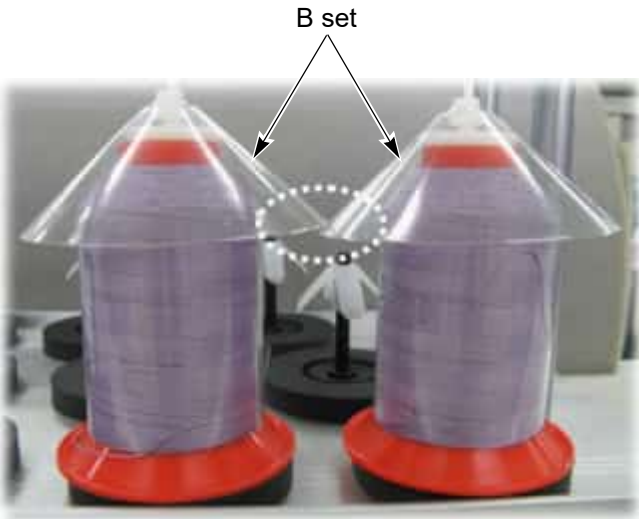

Attach or detach B set carefully.

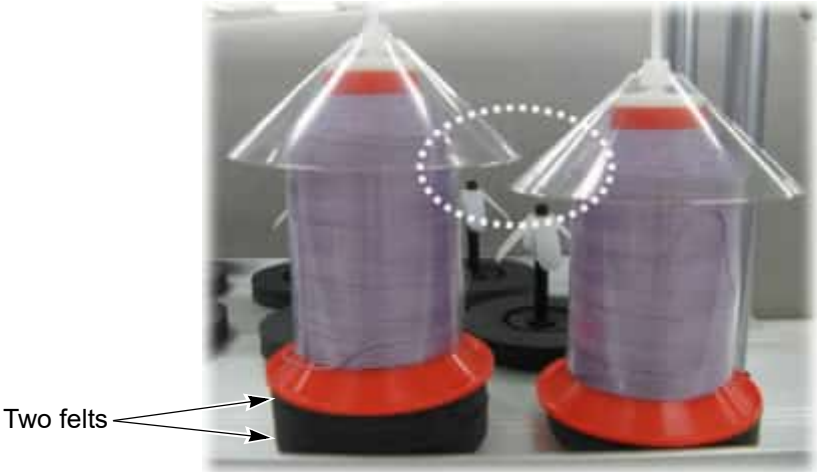

2-3. To thread

If the thread does not pass to each section correctly, it could cause trouble such as the deterioration of product or the thread breakage, etc. Pass the thread correctly referring to the figure below.

- (1) Place the thread cone on the thread stand blade.
- (2) Thread through the thread course.
- (3) Thread into grooves (indicated by arrows) of the first tension and the second tension.

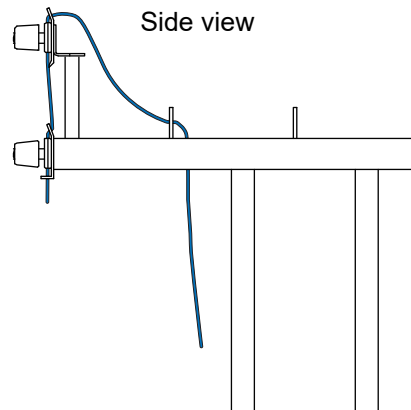

To play the video, Adobe Flash Player is necessary. Press the play button as shown above, and follow the displayed screen to install Adobe Flash Player.
To close the video, scroll down to the next page.

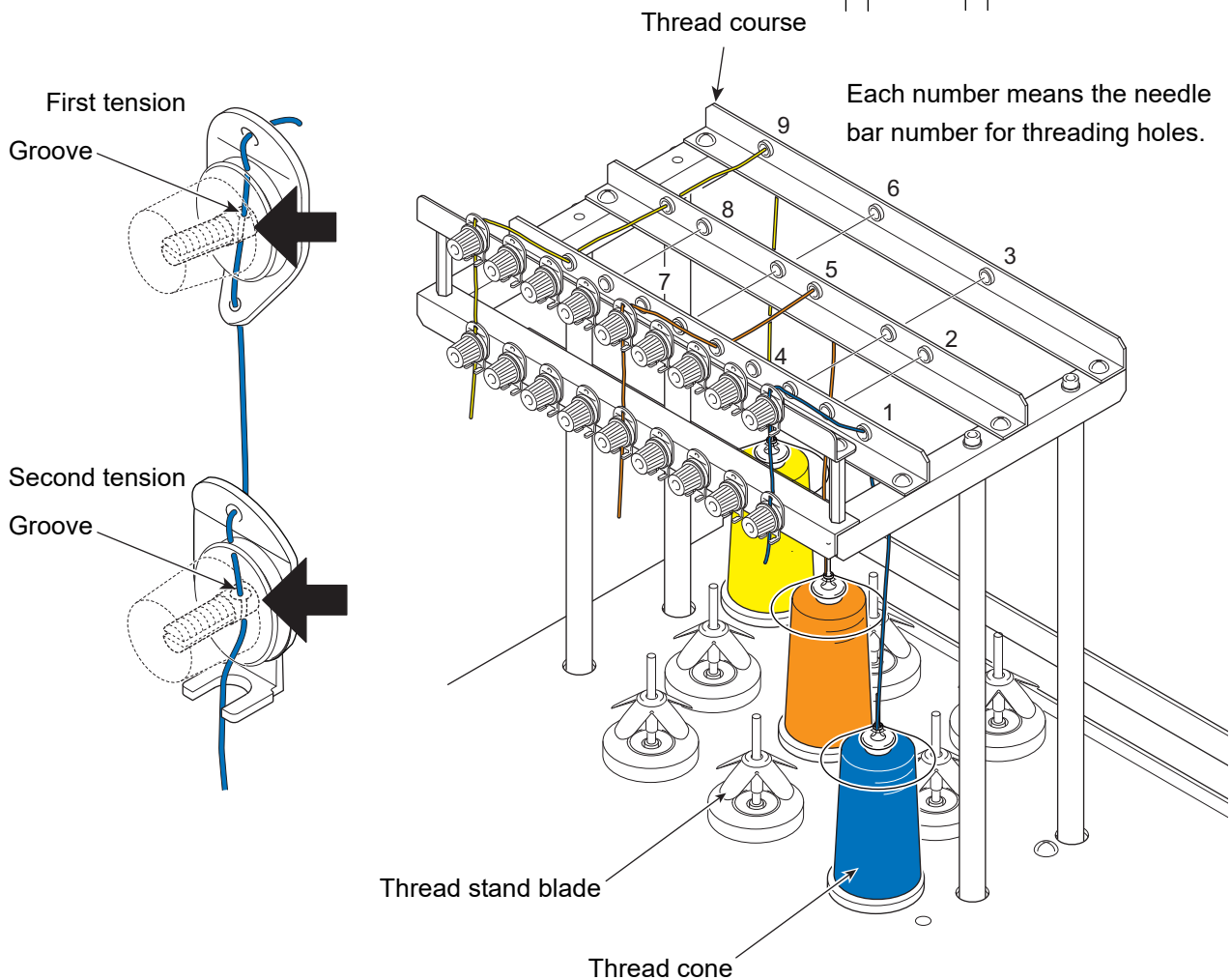

- (4) To perform threading through the spiral tube, use the threader (accessory).
- (5) Thread into the groove (indicated by an arrow) of the third tension.

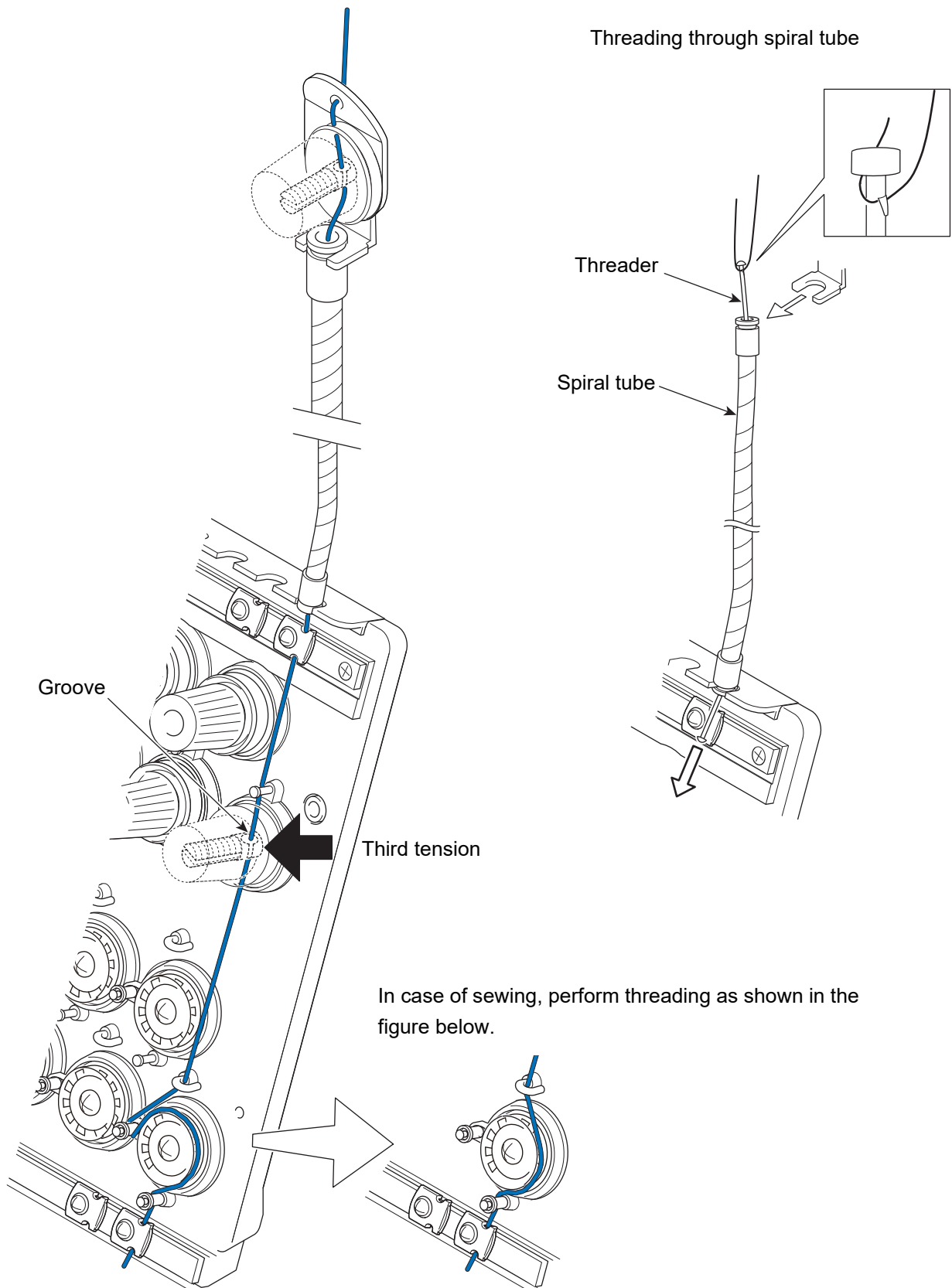

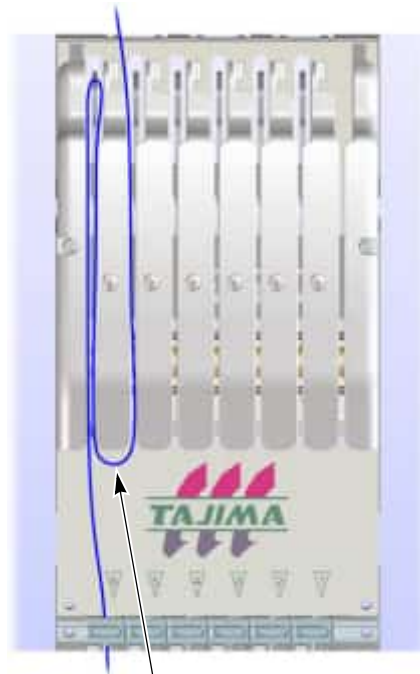
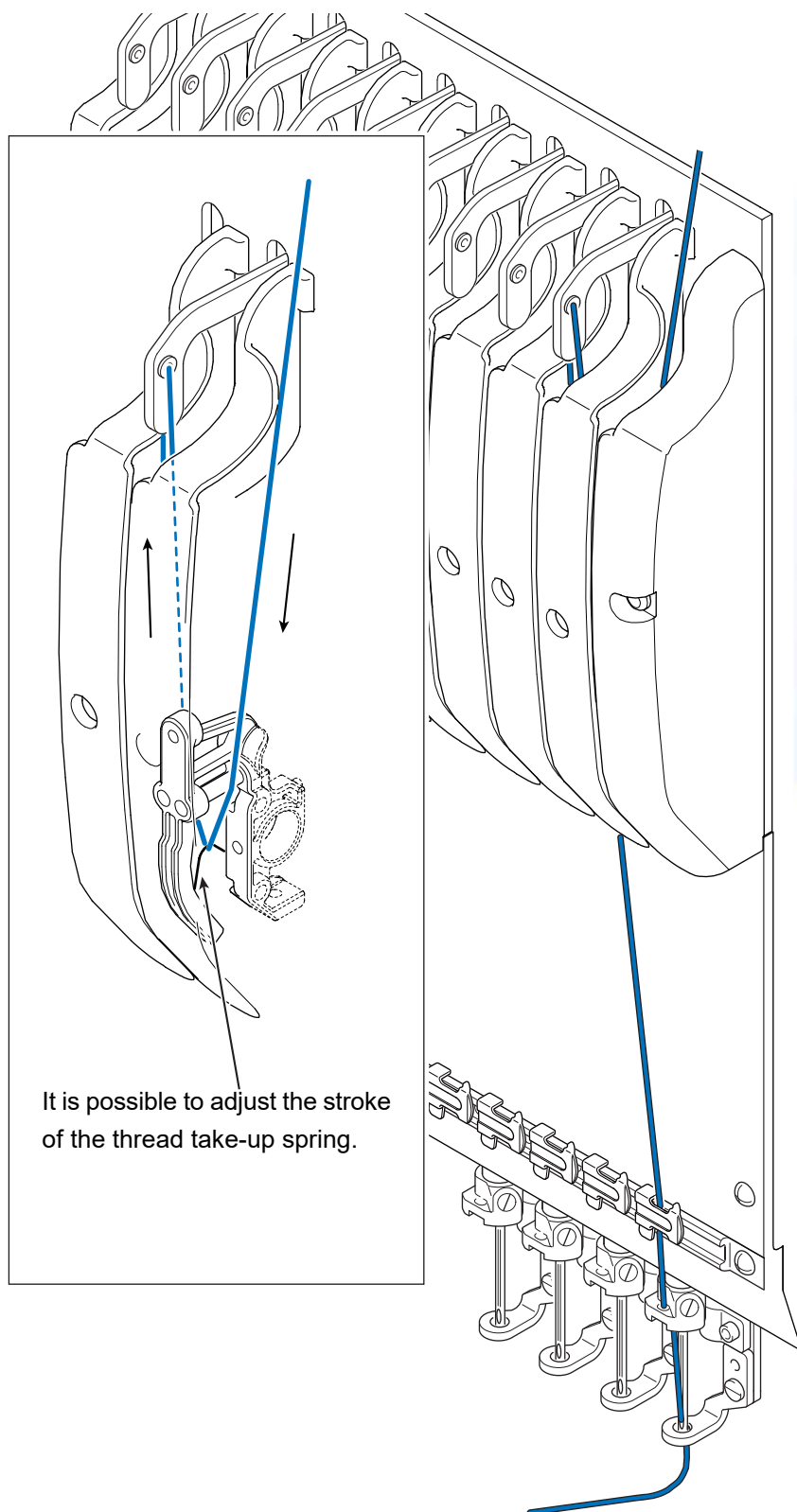

It is possible to perform threading easily by just hooking the thread here. (One-touch middle thread guide)

3. To input design to machine memory

The machine memory function has sewing mode screen and embroidery mode screen.

Save the design to use for sewing (sewing design) into sewing mode screen, and save the design to use for embroidery (embroidery design) into embroidery mode screen (→p.44)

(1) Sewing design

Up to 3000 designs at the maximum can be registered. (Up to 2,000,000 stitches at the maximum for one design)

Main: 1000 designs

Pattern 1 to 4: 500 designs each

Sewing design will be assigned to No. 1001 to 3999 of the machine memory automatically. The machine memory is changeable. (→p.172)

(2) Embroidery design

Up to 650 designs at the maximum can be registered. (Up to 2,000,000 stitches at the maximum for one design)

Main: 200 designs

Group 1 to 5: 90 designs each

The embroidery design will be assigned to No. 1 to 650 of the machine memory automatically. The machine memory is not changeable.

3-1. To input design in USB memory to machine memory

Hereafter, icons are referred as icon A and icon B derived from each alphabet positioned at upper right of each icon.

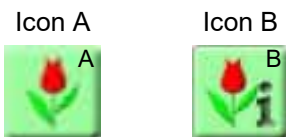

It is possible to register the condition data (Color change sequence, Start position) included in the design in USB memory into the machine memory.

This enables to omit the setting of the color change sequence, the start position and the presser foot.

[How to operate]

Select two designs in the USB memory and input them into "Pattern-Main" of the machine memory.

(1) To set USB memory

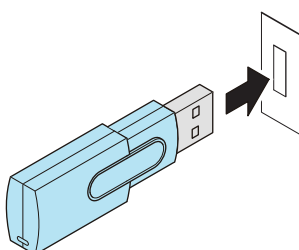

(2) Icon A



(3) Icon B

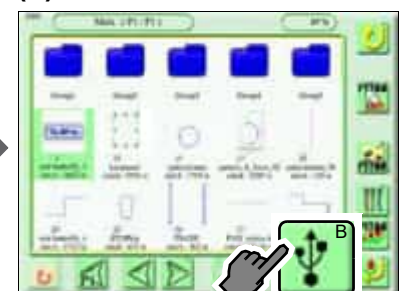

(4) 1st design

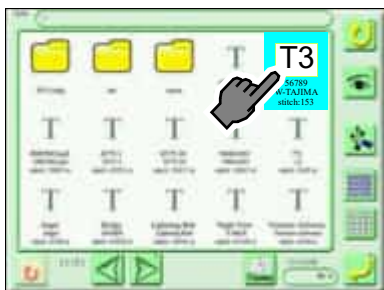

For the screen 3100 of the left figure, refer to the detail page. (→p.39)



If this icon is pressed, all designs will be selected.



If this icon is pressed, selecting the design will be

(5) 2nd design

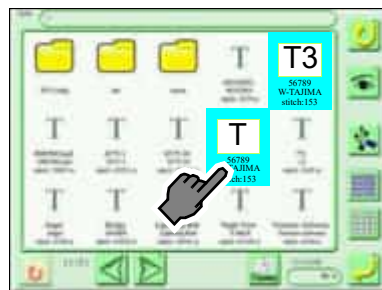

(6) To set

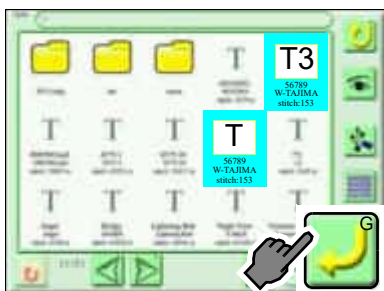

When the numbers of designs exceed the machine memory capacity or the machine memory capacity is not enough, the code No. 2BA will be displayed.

(7) Pattern-Main

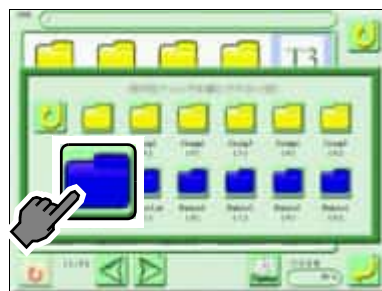

(8) Screen 2000 (Completed)



When sewing this design continuously, proceed to the following operation.

"To decide design to stitch (Data set)" (→p.97)

3-2. To input design in personal computer to machine memory

Software sold separately (DG/ML by Pulse) is necessary to perform this operation.

The below operating example is inputting method of data by "DG/ML by Pulse".

[How to operate]

Select two designs to input into "Pattern 4" of the machine memory.

- (1) Turn OFF the power of the personal computer and the machine.
- (2) Connect the personal computer to the machine with LAN cable.

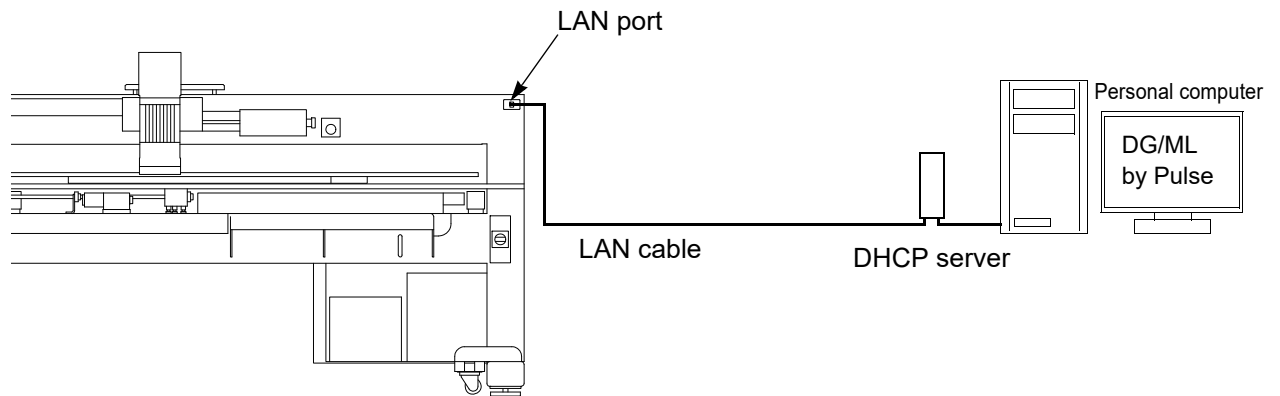

- (3) Turn ON the power of the personal computer, and start up DG/ML by Pulse.
- (4) Turn ON the machine power, and set "1 Network" to "DG/ML[V1]".

(5) Icon A

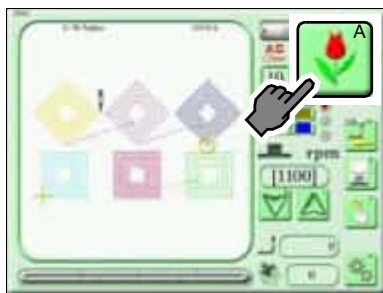

(6) Icon C

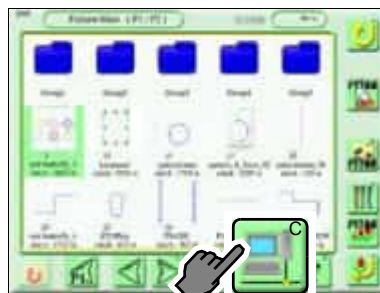

For DG/ML by Pulse, the below icons will appear.

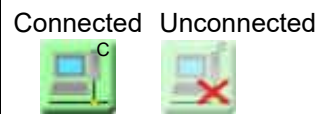

For Sidekick, the below icons will appear.

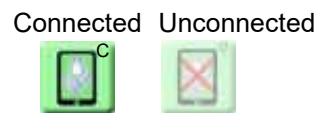

(7) 1st design

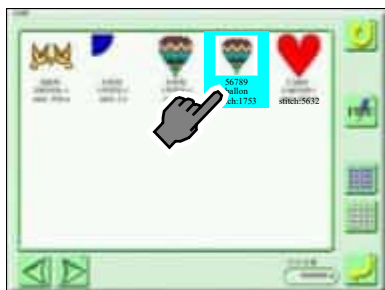

(8) 2nd design

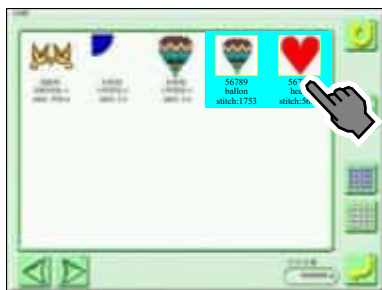

To search the design from file name, after selecting icon D, input file name.

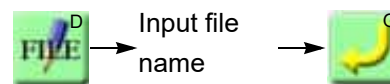

(9) To set

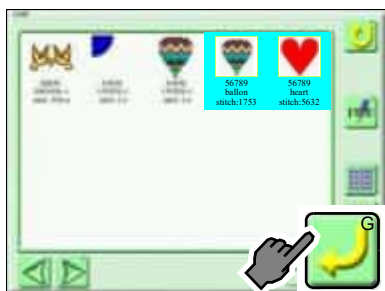

(10) Pattern 4



(11) Screen 2000



Registration is completed. When sewing this design continuously, proceed to the following operation.

"To decide design to stitch (Data set)" (→p.97)

3-3. To input design in personal computer to machine memory (Using a bar code reader)

Select the design (saved in DG/ML by Pulse) by the bar code reader and input it to the machine memory. Regarding the bar code reader, prepare a commercial item. To perform this operation, software sold separately (DG/ML by Pulse) is necessary.

[How to operate]

- (1)** Turn OFF the power of the personal computer and the machine.
- (2)** Connect the personal computer to the machine with LAN cable.
- (3)** Turn ON the power of the personal computer, and start up DG/ML by Pulse.
- (4)** Turn ON the machine power, and set "1 Network" to "DG/ML[V1]".
- (5)** Connect the bar code reader to the USB port of the operation panel.

Bar code reader

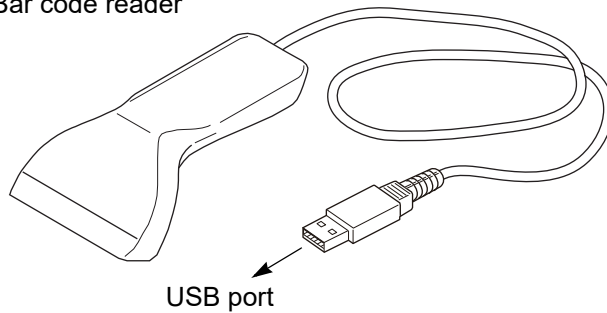

- (6)** Set to the main screen.

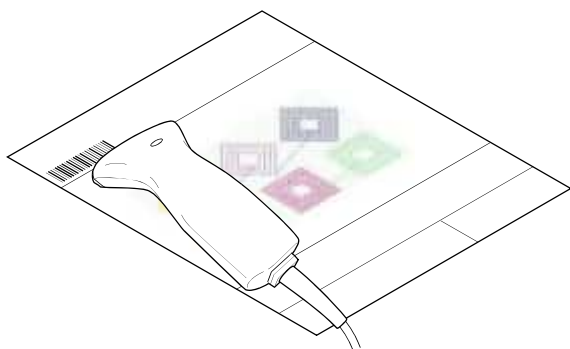

(7) Read the bar code by using the bar code reader.

Bar codes can be printed by the print function of DG/ML by Pulse.

The bar code can be read also from the following screen.

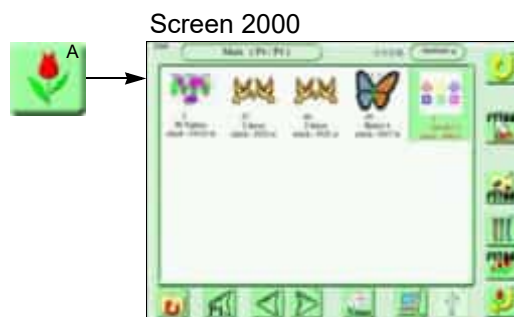

In addition, bar codes can be read also from the following screens.

Screen 4100, Screen 4150

If the bar code of the next sewing design is read by the bar code reader during the operation (the design read here is called "Pre-read design"), the data of the pre-read design will be set at the end of current sewing design and a yellow bar will be displayed.

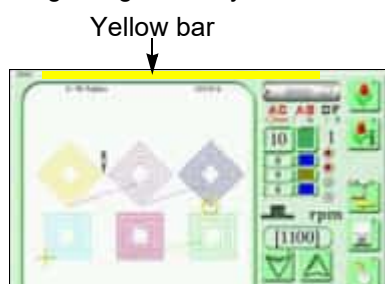

When performing the following operation, the yellow key will disappear.

1. When performing panel operation
2. When the machine is started/stopped
3. When the power is turned OFF and ON, etc.

The pre-read design requires the following conditions.

1. The design which can be performed pre-reading is one design only.
2. When the bar codes are read plural times during operation, the design read latest will be selected.
3. When suspending to sew the design during operation and setting the data of other design, the pre-read design will be deleted.
4. When suspending to sew the design during operation and setting the data of the pre-read design, read the bar code again.

4. To decide design to stitch (Data set)

CAUTION

 When performing this operation, do not put your hands, etc. on the table. Moving the frame could injure you.

[How to operate]

Select one design from sewing designs saved in the machine memory.

(1) Icon A



(2) Sewing design

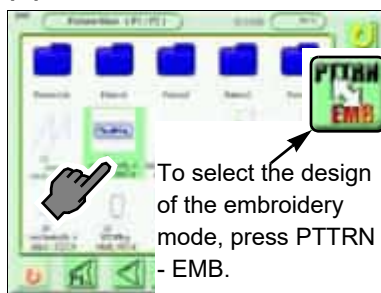

(3) To set

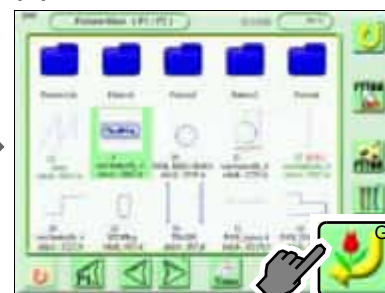

(4) Yes

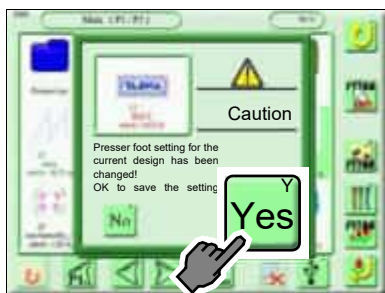

"Presser foot setting saving screen" in the left figure may be displayed depending on the setting condition. Refer to the detail page. (→p.41)

(5) Yes



[When sewing design is selected]

Confirmation screen of travel to "Start Position" will be displayed, then perform setting. The frame will move to the start position after setting.

When changing the start position, refer to the detail page. (→p.185)

(6) To set (Completed)

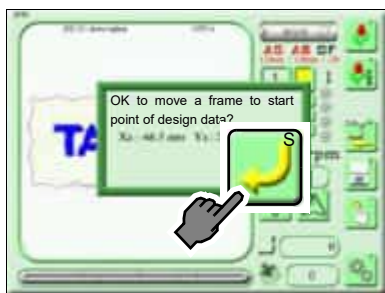

The screen described left shows normal message. When the offset position is set, the message below will be displayed.

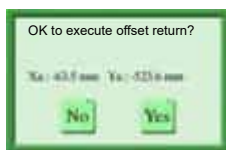

[When embroidery design is selected]

When "Start position" or "Offset position" is set in the embroidery design, the below display will appear.

Pressing "Yes" will move the frame.

(6) Yes (Completed)



The screen described left shows the message when the start position is set. When the offset position is set, the message below will be displayed.

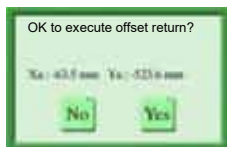

5. To decide sewing mode

5-1. To perform color change and start operation automatically

According to usage order of needle bars, set "To perform" / "Not to perform" Color Change automatically. To sew with single color irrespective of using order, set "Auto Color Change" to "No". If "No" is selected at "Auto Color Change", it is not possible to set "Auto start" or "Auto start after auto data set".

[How to operate]

Auto Color Change and Auto Start are performed.

(1) Icon G



(2) Auto Color Change, Yes

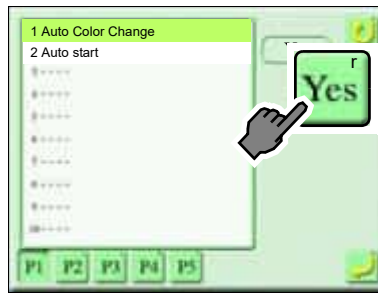

(3) Auto Start



(4) Yes

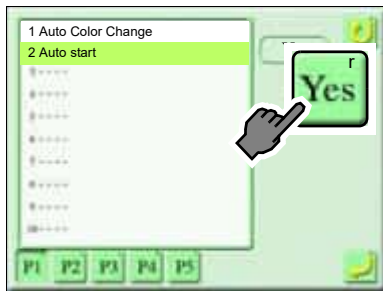

(5) To set (Completed)

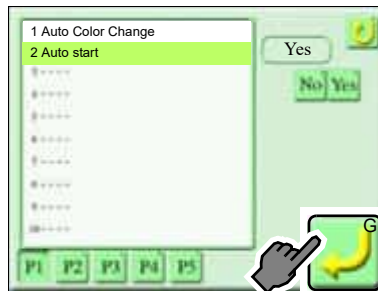

5-2. To decide using order of needle bars

This setting is effective only when Auto Color Change is set to "Yes".

When the order of using needle bars is already included in the design to be sewn from now as the condition data, this setting is unnecessary.

[How to operate]

Set Step 1 to the needle bar No. 4 and Step 2 to the needle bar No. 6.

(1) Icon A

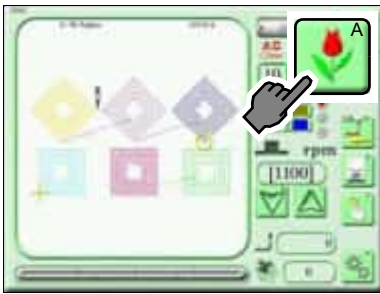

(2) Design

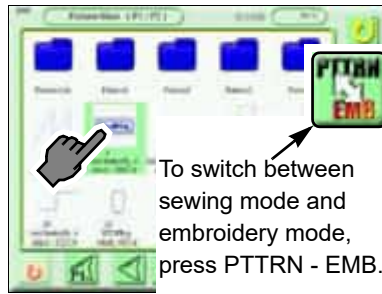

(3) Icon E

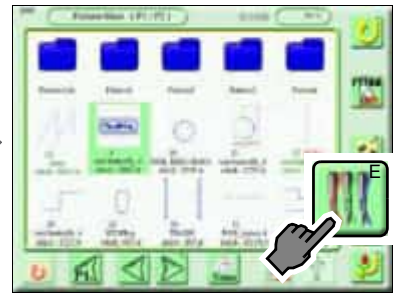

(4) Step 1, needle No.4

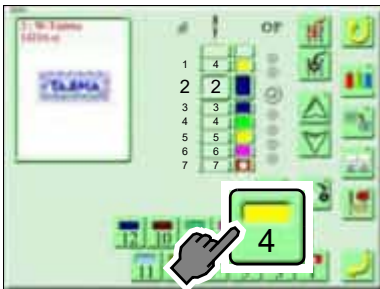

For the screen 2010 of the left figure, refer to the detail page. (→p.43)

(5) Step 2, needle No. 6

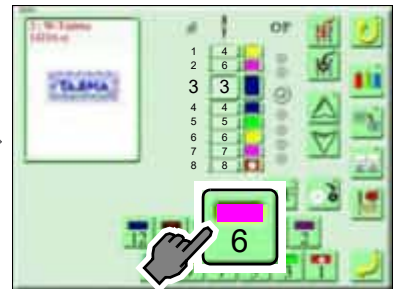

(6) To set (Completed)

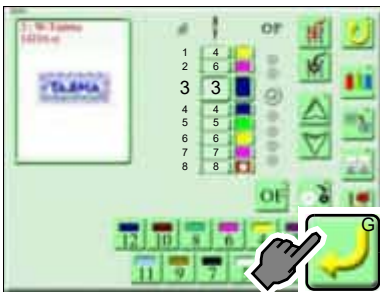

[How to operate]

Set Step 3 to the needle bar No. 6.

(1) Step 3

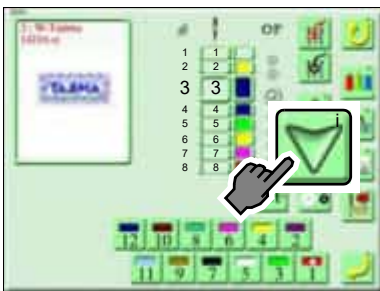

(2) Needle bar No. 6

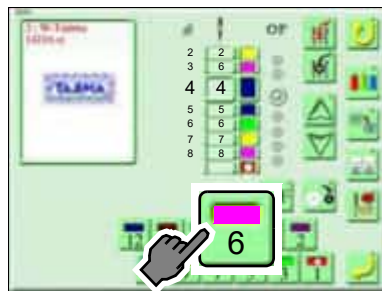

(3) To set (Completed)

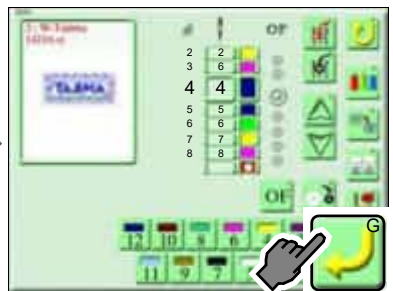

6. Items to check

6-1. To check size of design and setting contents

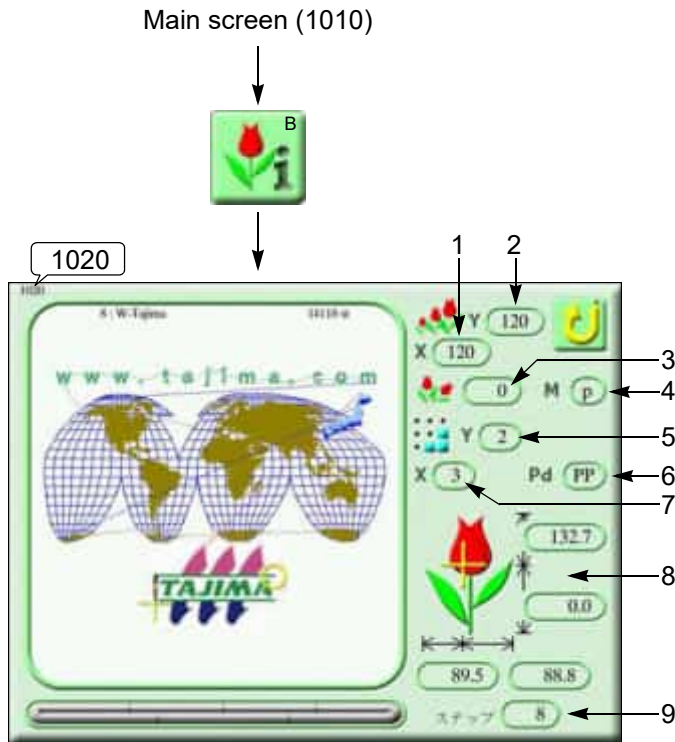

1. Scale ratio of design (Horizontal)
2. Scale ratio of design (Vertical)
3. Rotating angle of design
4. Reverse of design
p: Not to perform q: To perform
5. Number of repeats of design (Vertical)
6. Repeat method
7. Number of repeats of design (horizontal)
8. Size of design (mm)
The size after scaling up/down will be displayed on the base of the start position.

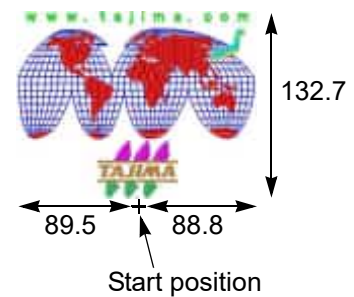

9. Number of steps of design

6-2. To check sewing head

Check if the left lamp of sewing head is lit in green. When the left lamp of sewing head is unlit, set the left switch to the middle position. The left lamp at that head will be lit in green.

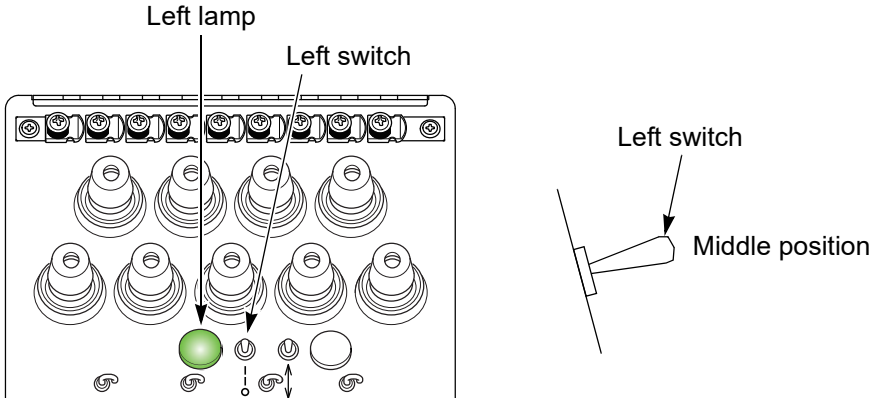

6-3. To decide maximum speed

The maximum speed means the maximum value of sewing speed. Sewing speed will increase/decrease automatically according to the stitch length (sewing interval) of the design during operation.

Besides, when the stroke mode of the presser foot is set to "M", the maximum speed sometimes may not be reached. In a example of the chart below, the maximum speed of the machine is limited to 940 rpm to give priority to the presser foot stroke (15 mm).

Setting of maximum speed on operation panel	1100 rpm
Presser foot stroke mode (→p.126)	M
Presser foot stroke (→p.126)	15 mm

When you want to increase the maximum speed to 1100 rpm, set the presser foot stroke mode to "A". If "A" is set, the stroke amount of the presser foot will change at a uniform ratio according to sewing speed.

When you want to increase the maximum speed to 1100 rpm in the state that the presser foot stroke mode is "M", set the presser foot stroke to "11 mm or less".

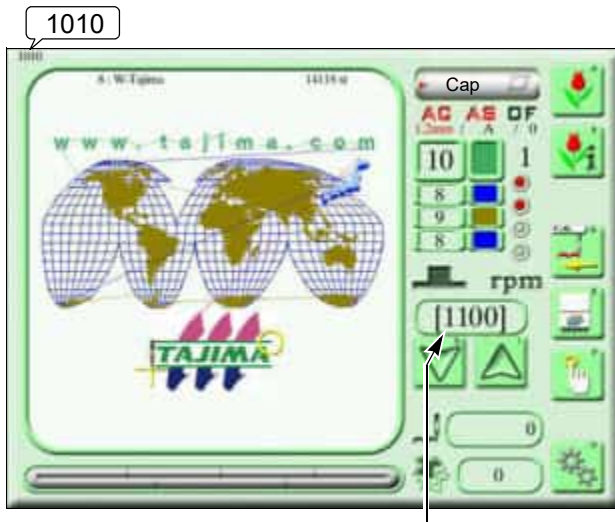

Maximum speed

Maximum speed
The maximum speed will be displayed by [] during stop of the machine.

To change the maximum speed during stop or operating of the machine, press the following icons.

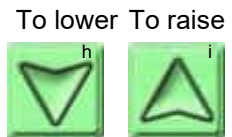

Keeping to press it will cause the value to be fast-forwarded.

7. To move frame to start position

This operation is available for the embroidery frame.

Perform this operation when moving the frame to the start position manually.

To change the start position of sewing design, refer to the detail page. (→p.185)

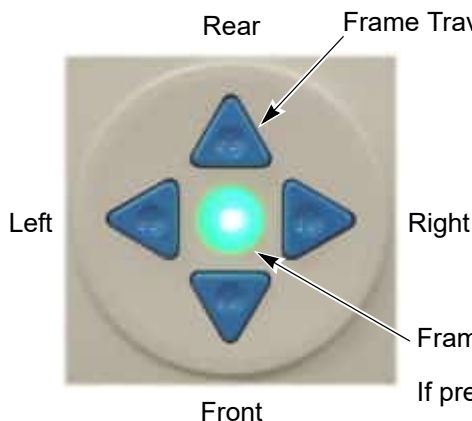

Frame Travel by frame travel key

It is possible to set the frame travel direction to right, left, rear, front or reverse side. (→p.272)

Frame Travel speed switching key

If pressing this key, the frame travel speed will change.

Low speed: Key will be unlit.

Middle speed: Key will be lit.

High speed:

Press the frame travel key while pressing the speed switching key.

The current frame position can be checked on the screen 6030.

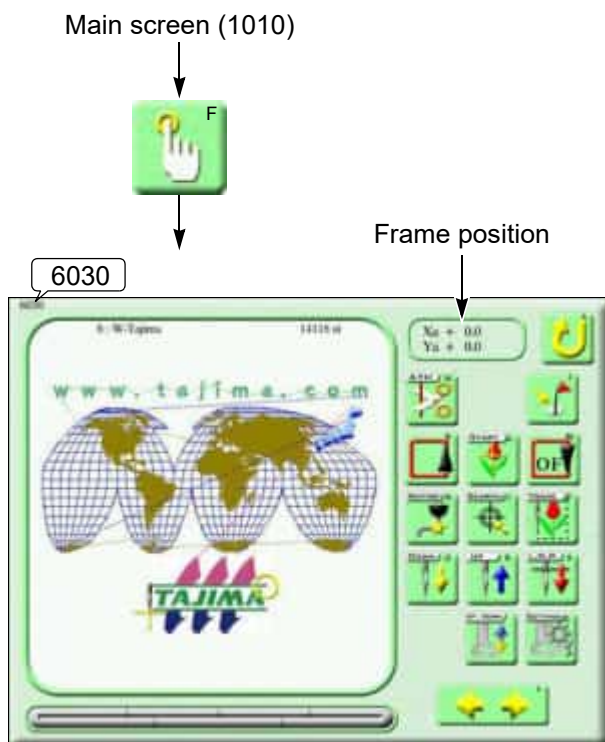

Selecting coordinates icon will change the indication.

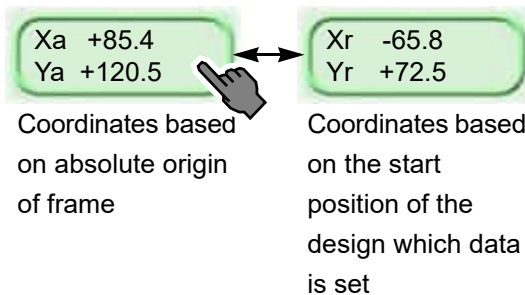

Coordinates based on absolute origin of frame

Coordinates based on the start position of the design which data is set

8. Trace

It is possible to check the size of the design by moving the frame along the design before sewing. (→p.55)
In the case of the embroidery design, executing Trace will memorize the start position.

! CAUTION

⊘ When performing this operation, do not put your hands, etc. on the table. Moving the frame could injure you.

[How to operate]

Trace will be executed by high speed frame travel.

(1) Icon F



(2) Icon P



(3) High speed frame travel
(Completed)



3 ← Current needle bar No.



High speed frame travel



Low speed frame travel

To interrupt working, press the stop switch. To start again, follow the operating screen.

When the start position is correct, the frame will move to the direction indicated by arrows from the start position and will stop after finishing Trace. (Figure A)

When the start position is incorrect, the frame will stop during operation and the error No. 225 will appear. Decide the start position again. (Figure B)

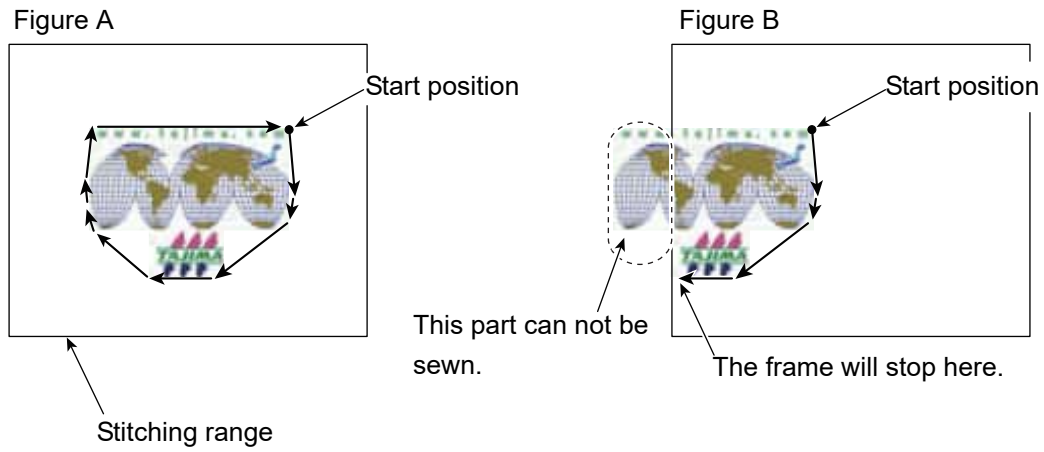

9. To start sewing

CAUTION

-  Before the start of the operation, pay enough attention to the surrounding safety. Moving the needle bar and/or the frame could injure you.

Bar switch



- (1)** When starting the operation, move the bar switch to the right and release it at once. If the bar switch is moved to the right and held at the position during the operation, sewing speed will go down and become slow operation.

Speed of slow operation

It is based on "Start/ATH inching r.p.m." of Parameter setting P7-71-3.

- (2)** To start slow operation from the state that the machine stops, move the bar switch to the right and keep the position. Releasing it will start normal operation.
- (3)** To stop the machine, move the bar switch to the left and release it.

9-1. Countermeasure against thread breakage

The machine will stop automatically. Besides, the left lamp at the head with thread breakage will switch to red (lit, or blinking). Code No. 291, that indicates thread breakage, will be displayed on the operation panel.

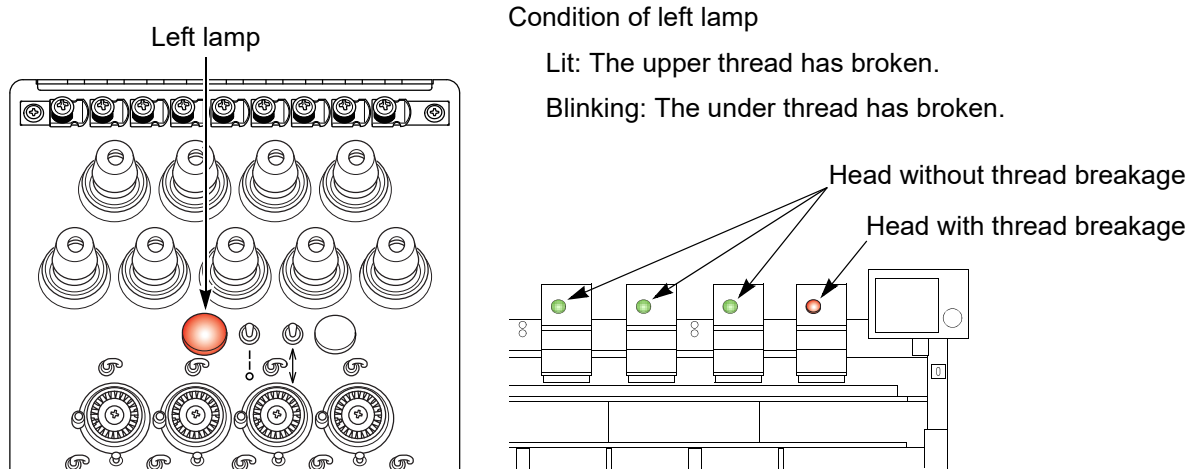

Restart sewing by the following procedure.

- (1) Pass the upper thread, or change the under thread (bobbin).

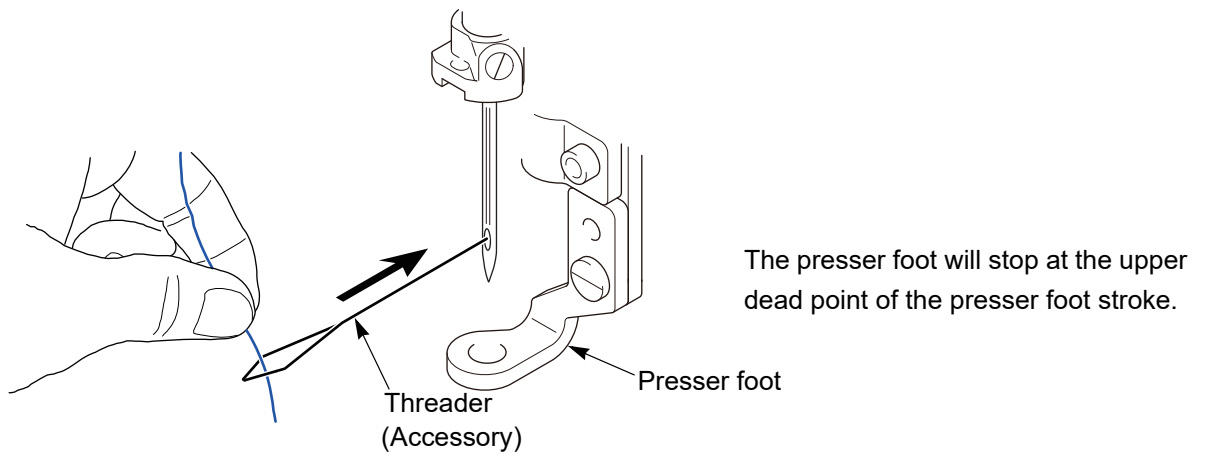

(2) Perform Frame Back by some stitches for repair stitches.

When you start the machine, only the head with thread breakage will start repair stitches from where Frame Back stopped.

When you want to perform return stitches at the beginning of repair stitches, raise the left switch once at the head with the thread breakage.

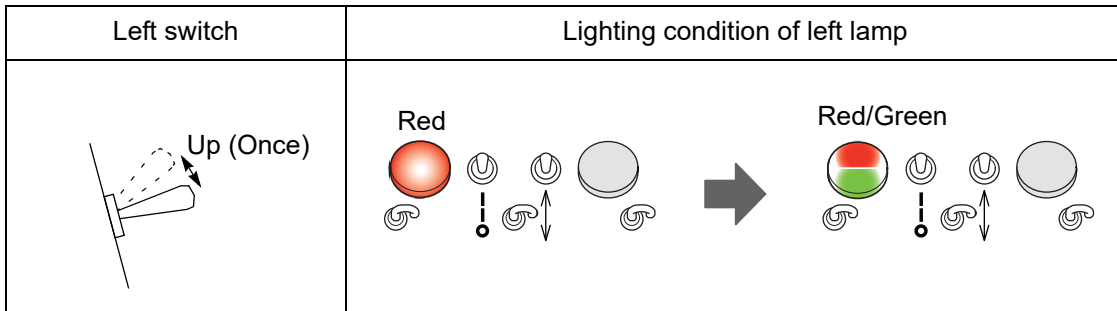

[Process from thread breakage to repair stitches]

a. After thread breakage occurs, the frame will move some stitches and then stop.

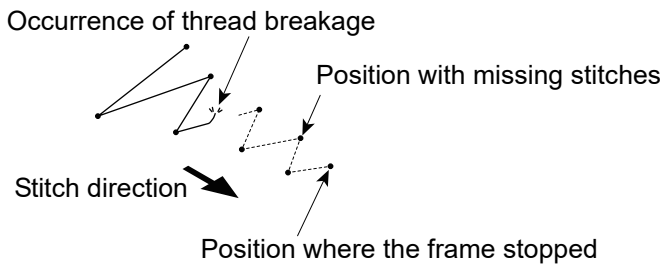

b. Perform Frame Back by several stitches.

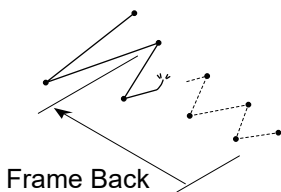

c. When starting the machine, repair stitches will be performed only at the head with thread breakage.

After that, all heads will start working and continue sewing.

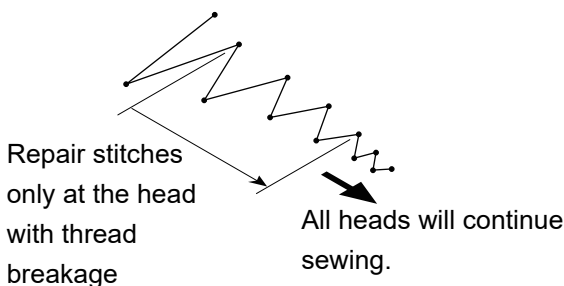

9-2. Completion of sewing

Destination of the frame movement differs depending on setting of the machine.

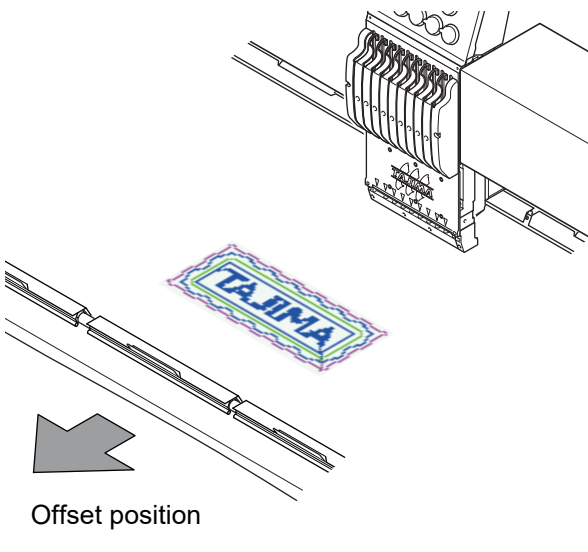
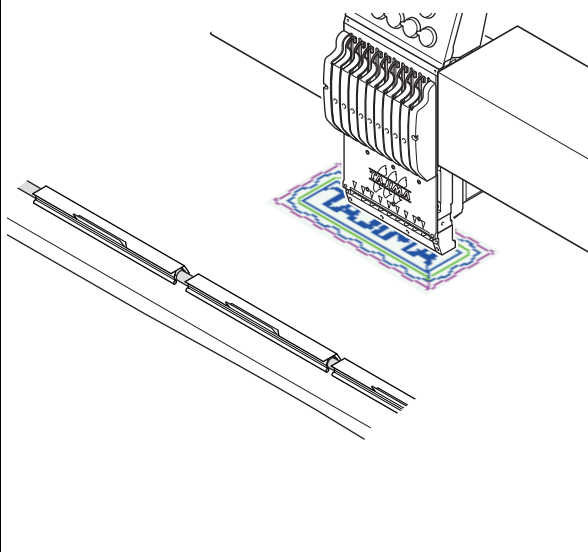
Setting of Automatic Offset	
With	Without
<p>The frame will move to the offset position. (→ p.52)</p> 	<p>The frame will not move. However, when Auto Origin Return has been set, the frame will move to the start position.</p> 

Chapter 6

Manual operation

1. To return frame, to advance frame	112
2. Thread trimming, color change	115
3. Frame Travel	117
4. Raising and lowering of needle bar	123
5. Raising and lowering of presser foot	125
6. Others	129

1. To return frame, to advance frame

Frame Back (to return frame):

The frame will be moved to the direction where stitches return with the needle bar stopped.

When a thread broke, perform Frame Back by a few stitches automatically.(→p.238)

Frame Forward (to advance frame):

The frame will be moved to the direction where stitches advance with the needle bar stopped.

There are following three types of the frame travel by Frame Back, Frame Forward.

(1) Frame travel by 1-stitch unit

Perform by using the bar switch.(→p.19)

(2) Frame travel specifying number of stitches (Frame travel for number of stitches)

Execute on the operation panel.(→p.113)

(3) Frame travel by Stop code

Execute on the operation panel.(→p.114)

1-1. To switch Frame back, Frame forward

[How to operate]

Switch from Frame Back to Frame Forward.

(1) Icon D



(2) Icon h (Completed)



Every time pressing icon h will switch to Frame Back (FB), Frame Forward (FF).

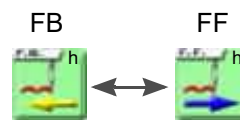

1-2. To perform Frame Back, Frame Forward (Specification by number of stitches)

Perform Frame Back or Frame Forward for all stitches being set together.

! CAUTION

⊘ When performing this operation, do not put your hands, etc. on the table. Moving the frame could injure you.

[How to operate]

Perform Frame Forward for 500 stitches altogether.

(1) Icon D



(2) Icon h



Pressing icon h will switch the screen display from Frame Back (FB) to Frame Forward (FF).



(3) To input 500

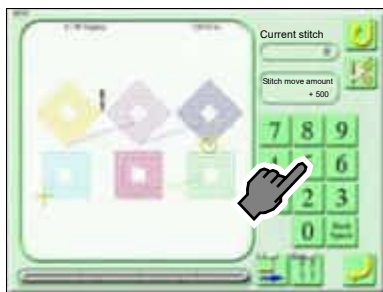

(4) To set (Completed)



1-3. To perform Frame Back, Frame Forward (Stop code)

Perform Frame Back or Frame Forward by Stop code.

CAUTION

 When performing this operation, do not put your hands, etc. on the table. Moving the frame could injure you.

[How to operate]

Perform Frame Forward for five times of color change code.

(1) Icon D



(2) Icon h



Pressing icon h will switch the screen display from Frame Back (FB) to Frame Forward (FF).

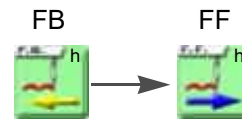

(3) Icon i



Every time selecting icon i will select the next color change code.

An example when selecting color change code five times

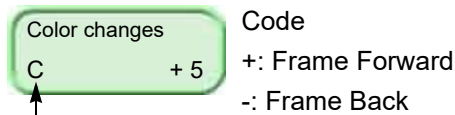

The last color change code will be displayed as "E"

(4) To set (Completed)



2. Thread trimming, color change

2-1. To trim thread

CAUTION

 When performing this operation, do not put your hands etc. near the needle or on the table. Moving needle bar or frame could injure you.

[How to operate]

Trim upper/under threads.

(1) Icon F



(2) Icon H



(3) Icon B (Completed)

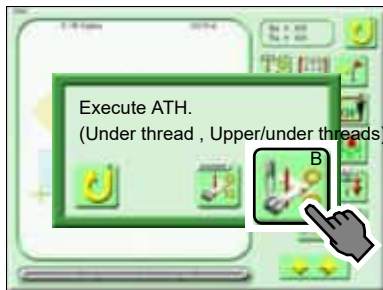

To trim under thread only



To trim upper/under threads

2-2. To change color**! CAUTION**

⊘ When performing this operation, do not put your hands etc. around the needle bar case. Moving needle bar case could injure you.

[How to operate]

Perform color change at 8th stitch.

(1) Icon E



(2) Needle bar No. 8



(3) To set (Completed)



3. Frame Travel

3-1. To move frame to registered position (Frame travel to optional position)

Move the frame to the position registered by parameter "39 Optional position".(→p.255)

! CAUTION

⊘ When performing this operation, do not put your hands, etc. on the table. Moving the frame could injure you.

[How to operate]



3-2. To return moved frame to previous position (Manual offset)

This function can be operated during sewing only.

! CAUTION

⊘ When performing this operation, do not put your hands, etc. on the table. Moving the frame could injure you.

[How to operate]



3-3. To return frame to start position (Start position return)

! CAUTION

⊘ When performing this operation, do not put your hands, etc. on the table. Moving the frame could injure you.

[How to operate]

(1) Icon F



(2) Icon L



(3) Yes (Completed)

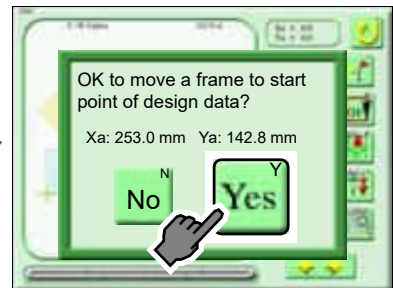

3-4. To move frame by inputting value (Input value for Frame Travel)

CAUTION

 When performing this operation, do not put your hands, etc. on the table. Moving the frame could injure you.

[Explanation of screen]

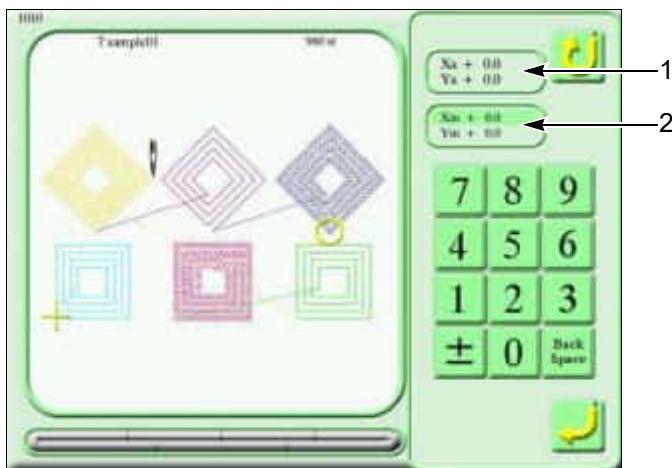

1. Current frame position

Selecting coordinates icon will change the indication.

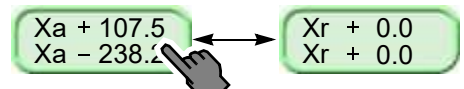

Coordinates based on absolute origin of frame

Coordinates based on the start position of the design which data is set

2. Frame Travel amount from current frame position

Horizontal

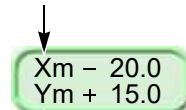

Vertical

[How to operate]

Move the frame by inputting the following value. The value is the moving amount from the current frame position.

X: +60.0 (mm), Y: -85.0 (mm)

(1) Icon F



(2) Input value icon



(3) Xm + 0.0

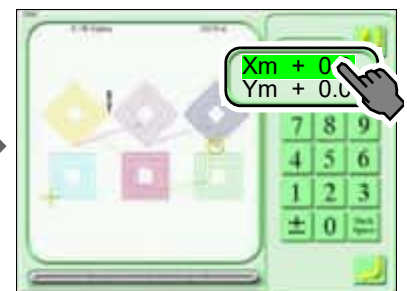

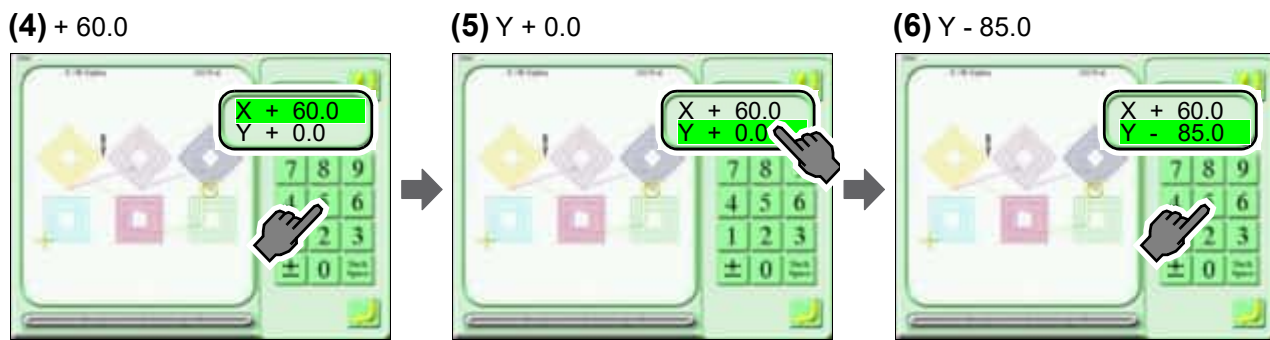

3-5. To move frame to registered position(Offset return)

It is possible to operate only when the offset position is registered.(→p.188)

⚠ CAUTION

⊘ When performing this operation, do not put your hands, etc. on the table. Moving the frame could injure you.

[How to operate]



3-6. To make machine memorize frame origin (Absolute origin search)

The frame origin is a reference point to calculate the frame position. (Xa:0.0, Ya:0.0)

Execute this function when moving the frame with the power turned OFF in changing frame etc. or when setting software frame limit.

If a frame origin is not correct, the following troubles will occur.

- (1) The frame coordinates are not displayed correctly.
- (2) The frame does not return to the interrupted position even after performing power resume, etc.

CAUTION

 When performing this operation, do not put your hands, etc. on the table. Moving the frame could injure you.

[How to operate]

(1) Icon F



(2) Icon O



(3) Yes (Completed)

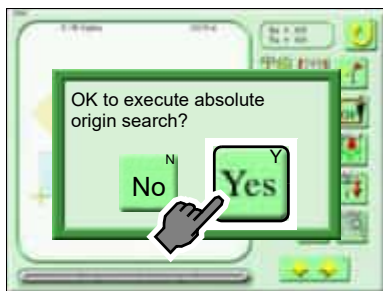

After Frame Travel, the frame will return to the previous position.

3-7. Operation when power is shut off (Power resume)

When the power is shut off by the emergency stop switch or the power failure etc., returning the frame to the previous position will prevent the design from displacing.(→p.17)

To perform origin return operation on the operation panel, follow the procedure below.

! CAUTION

 When performing this operation, do not put your hands, etc. on the table. Moving the frame could injure you.

[How to operate]

Execute the power resume after thread trimming

(1) Icon F



(2) Icon N



(3) To trim thread (Completed)



The frame will be moved after thread trimming.



Frame Travel will be performed without thread

(4) After Frame Travel, the frame may move forward by some stitches from the original position. Check the frame position, then restart sewing after performing Frame Back.

4. Raising and lowering of needle bar

4-1. To lower needle bar

Lower needle bars selected now at all heads together. Use this function to make positioning of the frame before sewing.

! CAUTION

⊘ When performing this operation, do not put your hands etc. near the needle or on the table. Moving up/down of the needle bar could injure you.

[How to operate]



4-2. To raise needle bar

! CAUTION

⊘ When performing this operation, do not put your hands etc. near the needle or on the table. Moving up/down of the needle bar could injure you.

[How to operate]



4-3. To lower needle bar to lower dead point

Lower needle bars selected now to lower dead points at all heads together. Performing this operation will cause the needle stuck in the fabric.

CAUTION

 When performing this operation, do not put your hands etc. near the needle or on the machine table. Moving down of the needle bar could injure you.

[How to operate]

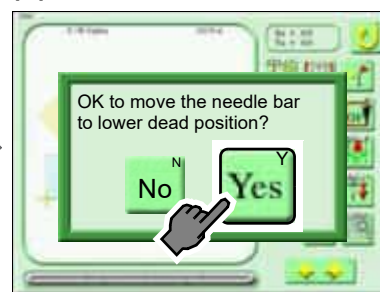
(1) Icon F**(2) Icon S****(3) Yes (Completed)**

5. Raising and lowering of presser foot

5-1. To lower/raise the presser foot

Raise/lower currently selected presser foots of needle bars at all heads together. (Needle bars will not lower.)

! CAUTION

⊘ When performing this operation, do not put your hands, etc near the needle or on the table. Moving up/down of the presser foot could injure you.

[How to operate]

Move down the presser foot to the lower dead point.

(1) Icon F





(2) Up/Down icon

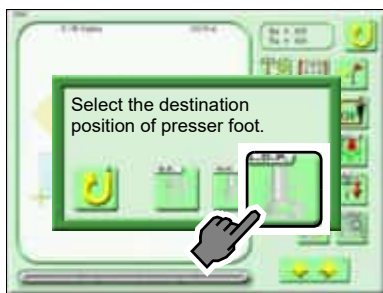

**(3) Lower dead point
(Completed)**



-  Retractable position(→ p.31)
-  FB position (Frame Back position)(→p.31)
-  Lower dead point(→p.31)

5-2. To set presser foot in unit of needle bar or step

[Setting screen]

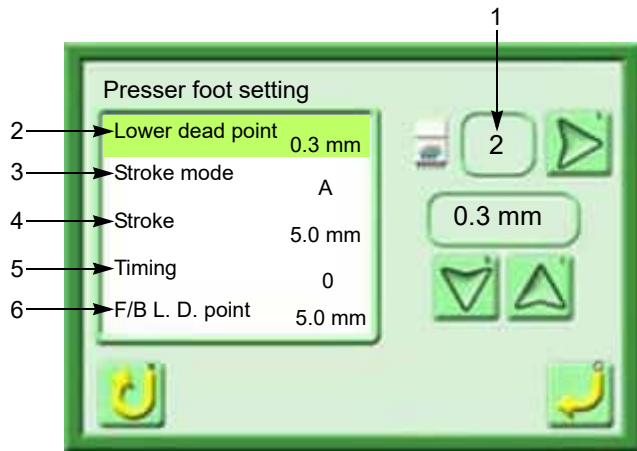

Stroke means up/down reciprocating motion of the presser foot.

1. Presser foot setting in unit of needle bar or step
Select one among Needle bar, Any or Step.
It is possible to set for the current needle bar or step.

In case of the current needle bar 2

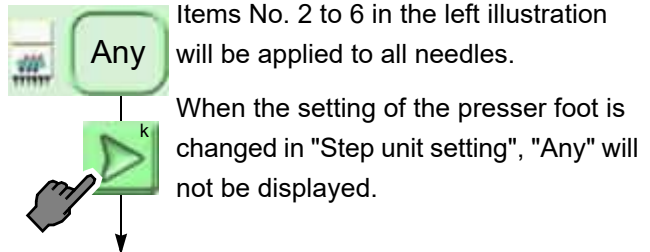
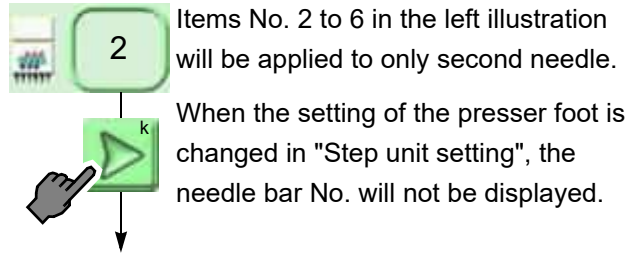

In case of the current Step 1

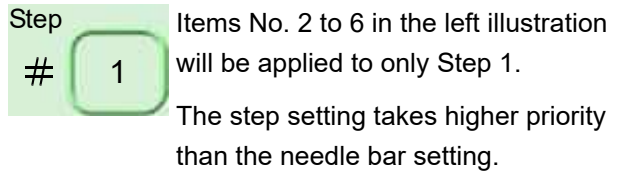

2. Distance (mm) between the presser foot and the needle plate when the presser foot moves down to the lower dead point

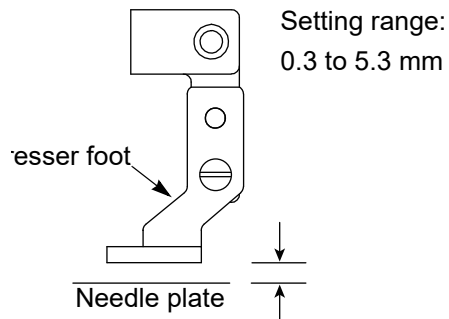

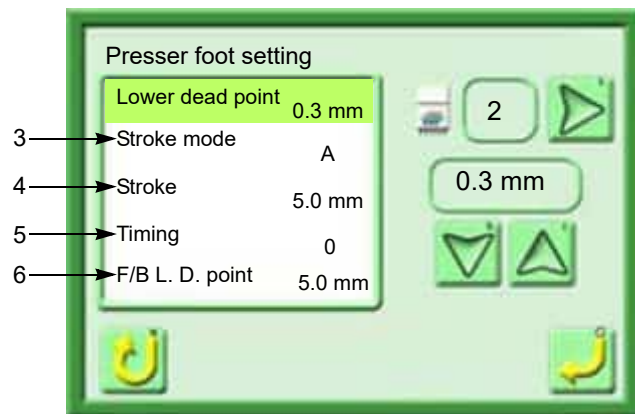

3. Stroke mode of presser foot

A: According to maximum speed of the machine, the presser foot will perform Stroke automatically

M: The maximum speed of the machine is limited depending on stroke amount. (The stroke amount is always fixed.)

Select "M" when sewing thick fabric mainly.

4. Stroke amount (mm) of presser foot

It is effective only when "Stroke mode" is set to "M".
Setting range: 0.0 to 25.0 mm

5. Timing when presser foot moves down

Setting range: -30 to +30

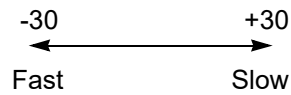

6. Presser foot lower dead point for Frame Back (Refer to 2)

Setting range: 5.0 to 25.0 mm

[How to operate]

Set the lower dead point of the presser foot to 1.0 mm, stroke mode to "M" and stroke amount to 15 mm.

(1) Icon F



(2) Icon D



(3) Lower dead point 1.0 (mm)

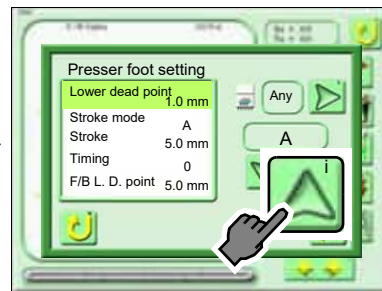

(4) Stroke mode

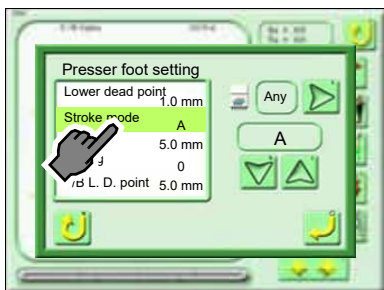

(5) M

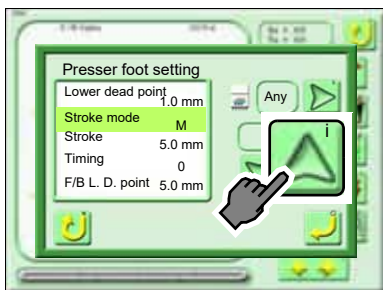

(6) Stroke

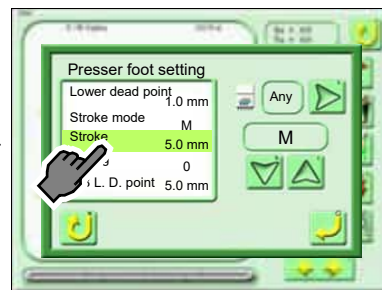

(7) 15 (mm)

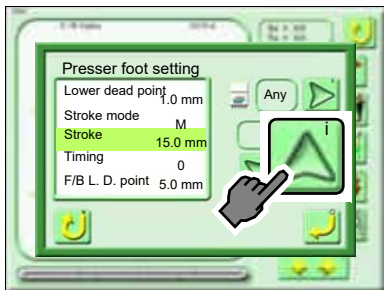

(8) To set (Completed)

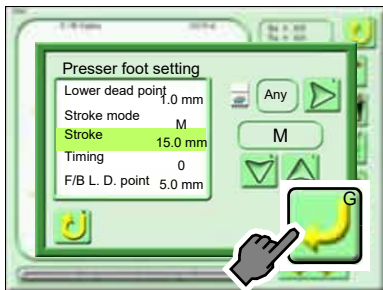

6. Others

6-1. To turn ON/OFF the LED lamp

[How to operate]

When optional device (Automatic lubrication system, or Sequin device etc.) has not been equipped

(1) Icon F



(2) Icon F (Completed)

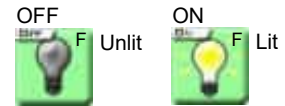

When optional device (Automatic lubrication system, or Sequin device etc.) has been equipped

(1) Icon F



(2) Icon e



(3) Icon F (Completed)

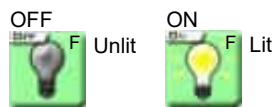

6-2. Machine log data download

Get the operation logs and the communication records. This function is for analyzing cause of some trouble of the machine. When your distributor asks to get log datas, send datas to your distributor saving log data information in the USB memory by the following operation.

[How to operate]

Save log data into the USB memory.

When optional device (Automatic lubrication system, or Sequin device etc.) has not been equipped

(1) To set USB memory

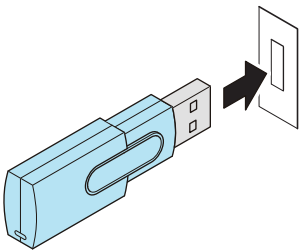

(2) Icon F



(3) Machine log



(4) IconB



Save on operation panel^[1]



Save into USB memory^[2]

(5) Take out the USB memory.
(Completed)

[1] Save the log data into the CF (Compact Flash Memory) inside of the operation panel up to 50 times. The log data exceeding 50 times will be overwritten. It is not possible to take out any data from the CF.

[2] Save log datas saved in the CF and log datas acquired at this time into the USB memory.

When optional device (Automatic lubrication system, or Sequin device etc.) has been equipped

(1) To set USB memory

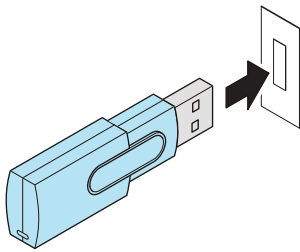

(2) Icon F



(3) Icon e



(4) Machine log



(5) Icon B



Save on operation panel^[1]



Save into USB memory^[2]

[1] Save the log data into the CF (Compact Flash Memory) inside of the operation panel up to 50 times. The log data exceeding 50 times will be overwritten. It is not possible to take out any data from the CF.

[2] Save log datas saved in the CF and log datas acquired at this time into the USB memory.

(6) Take out the USB memory.
(Completed)

Chapter 7

Delete, save and edit of design

1. To delete design	134
2. To save design, to change design name	137
3. To edit design	141
4. To copy, to divide and to combine design.....	158
5. To create sewing design.....	169

1. To delete design

1-1. To delete design in machine memory by one design unit

[An example of operation]

(1) Icon A

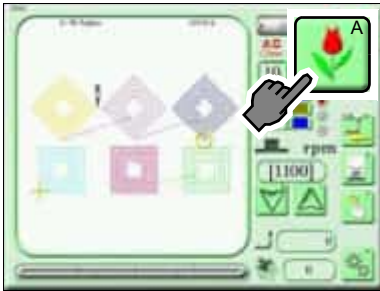

(2) Design

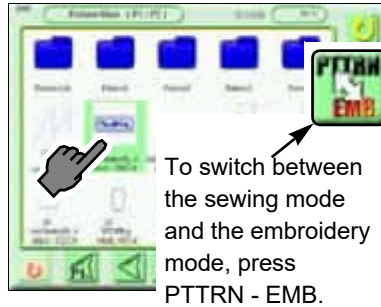

(3) Icon D

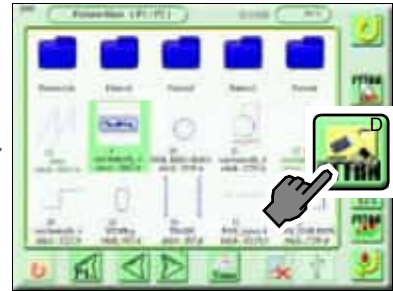

(4) To set

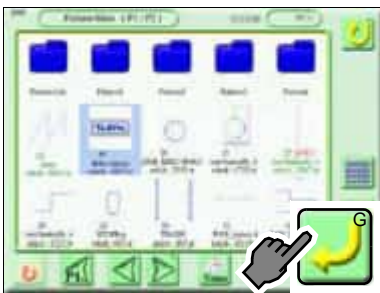

If this icon is pressed, all designs will be selected.



If this icon is pressed, selecting the design will be canceled.

(5) Icon I



(6) Yes (Completed)



When selecting the design of the set data, the following screen will appear.

(7) Yes (Completed)

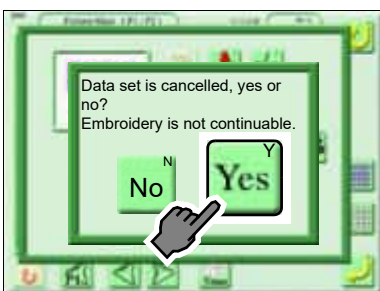

Pressing "Yes" will delete the design of which data is set.

1-2. To delete plural designs in machine memory

It is possible to delete designs in the same layer without limit.

[An example of operation]

Delete two designs.

(1) Icon A

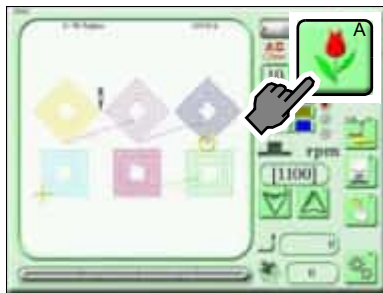

(2) 1st design

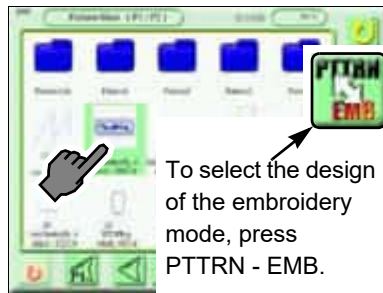

(3) Icon D

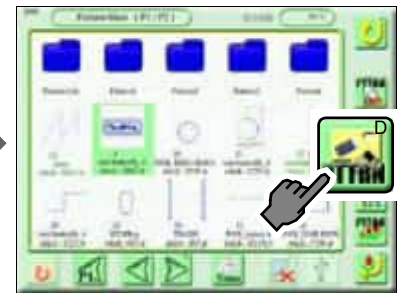

(4) 2nd design

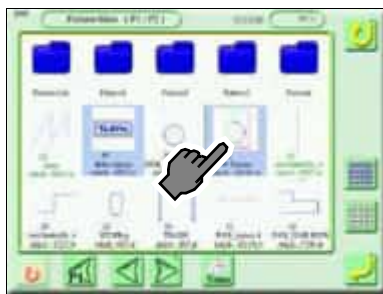

If this icon is pressed, all designs will be selected.



If this icon is pressed, selecting the design will be canceled.

(5) To set

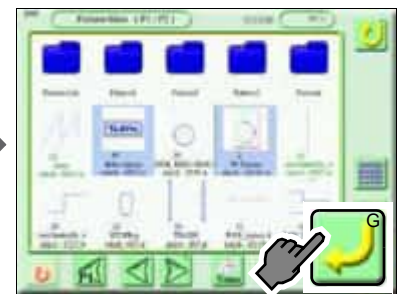

(6) Icon H



(7) Yes (Completed)



1-3. To delete design in USB memory

It is possible to delete designs in the same layer without limit.

[An example of operation]

Select two designs and delete them.

(1) To set USB memory.

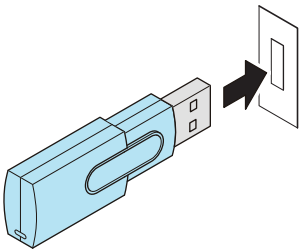

(2) Icon A



(3) Icon B

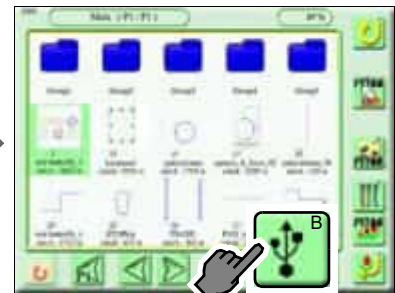

(4) 1st design

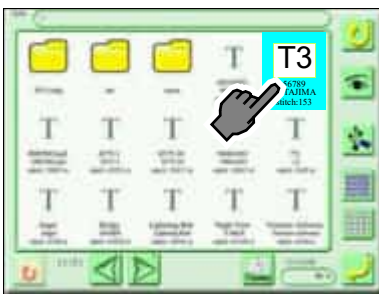

If this icon is pressed, all designs will be selected.



If this icon is pressed, selecting the design will be canceled.

(5) 2nd design

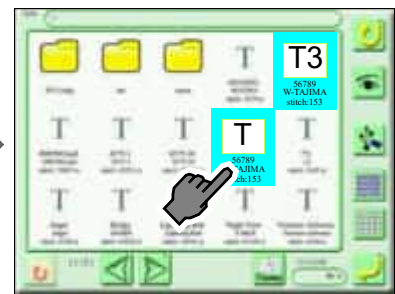

(6) Icon D

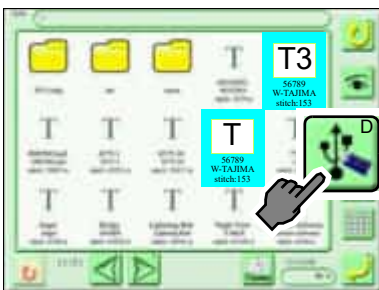

(7) Yes (Completed)



2. To save design, to change design name

2-1. To write design into a USB memory (Input of a password is necessary)

It is possible to write designs in the same layer into USB memory without limit.

To use this function, it is necessary to set the functional limit level to "SEL" by inputting a password.
(→p.232, p.229)

[An example of operation]

Select two designs and write them into USB memory with saving format "PTF".

(1) Set the functional limit level to "SEL". (→p.232, p.229)

(2) To set USB memory.

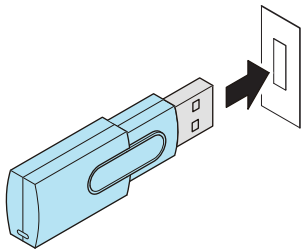

(3) Icon A



(4) 1st design

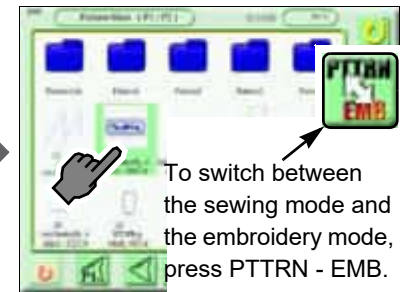

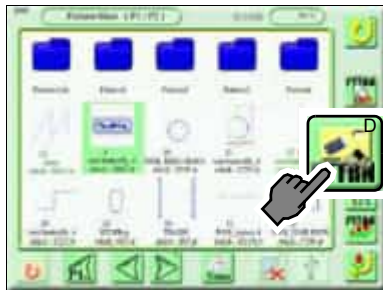

(5) Icon D

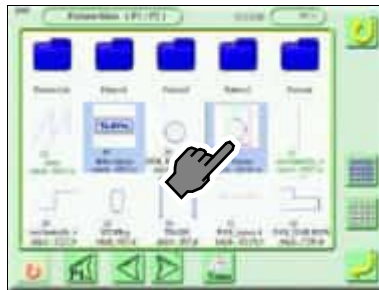

(6) 2nd design



-  If this icon is pressed, all designs will be selected.
-  If this icon is pressed, selecting the design will be canceled.

(7) To set

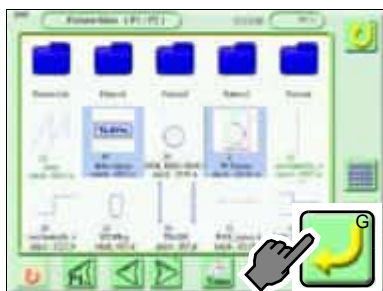

(8) Icon K



(9) File name^[1]



(10) Skip, to set



If there is the same name file in USB memory, treatment differs depending on the selected icon as follows.



The design will be saved with a different name.



A design will be overwritten.

[1]Input the number or alphabet. (Up to 20 characters) Characters input here will become a file name on a personal computer.

G0010.TCF

↑
File name on personal computer

(11) Saving format

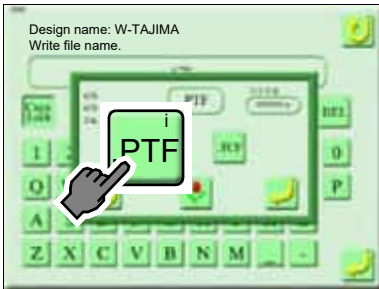

For sewing design, select PTF. PTF (Pulse Tajima Format) is the format that can "Modify the design in unit of the outline" having the outline information like design configuration and the sewing type information to generate.



For embroidery design, select TCF.

(12) Saving design

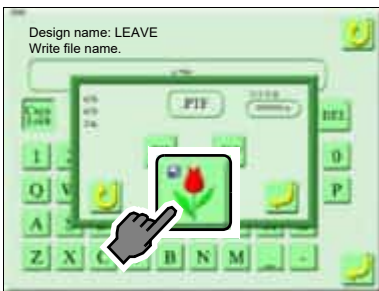

Save the selected design with the different saving format respectively.



Save all selected designs with the same saving format.

(13) To set

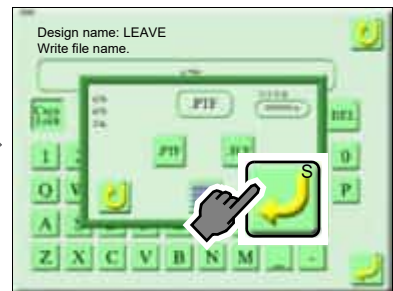

(14) Icon X (Completed)

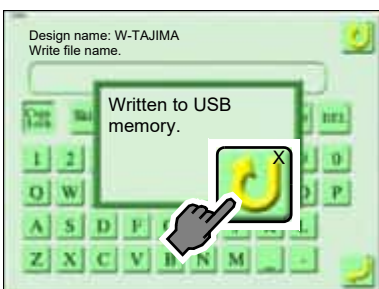

2-2. To change saving place of design

Move the saving place of the design saved in the machine memory. It is possible to change the saving place of the design in the same layer without limit.

[An example of operation]

Select two designs and move them to the machine memory "Pattern 1".

(1) Icon A



(2) 1st design

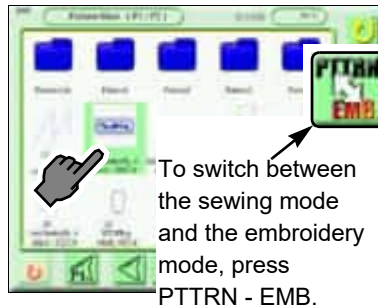

(3) Icon D

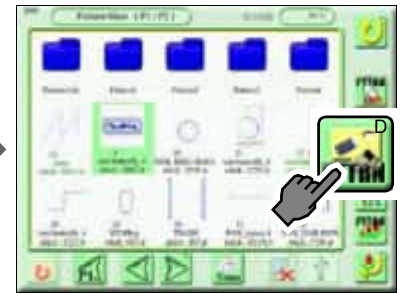

(4) 2nd design

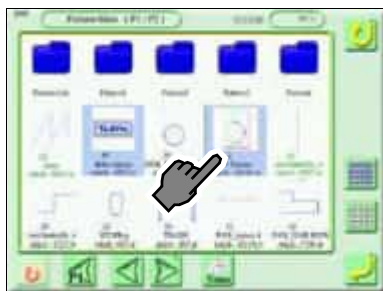

If this icon is pressed, all designs will be selected.



If this icon is pressed, selecting the design will be canceled.

(5) To set



(6) Icon D



(7) Pattern 1 (Completed)

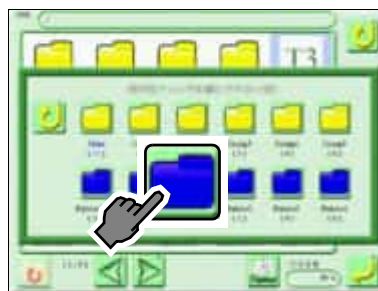

2-3. To change design name

Change the name of the design saved in the machine memory by one design unit.

[An example of operation]

(1) Icon A

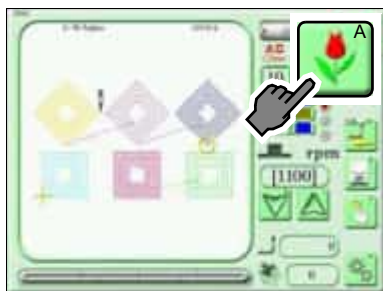

(2) Design

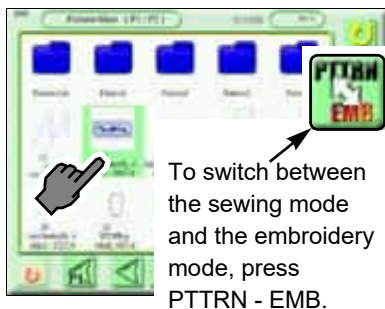

(3) Icon D

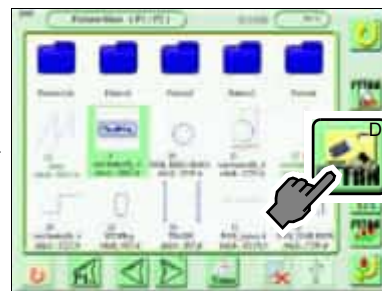

(4) To set

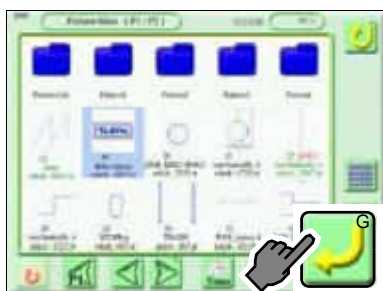

(5) Icon J



(6) To change design name^[1]

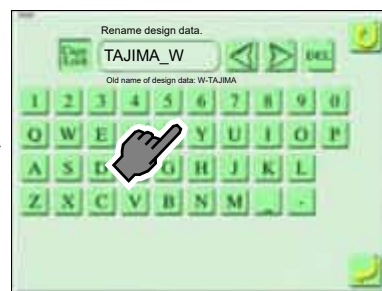

[1]Up to 8 characters can be set for a design name.

(7) Set (Completed)

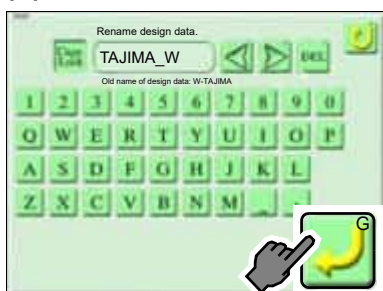

3. To edit design

The design saved in the machine memory is targeted.

3-1. To specify stitch No. to search stitch

[An example of operation]

Search 480th stitch.

(1) Icon A

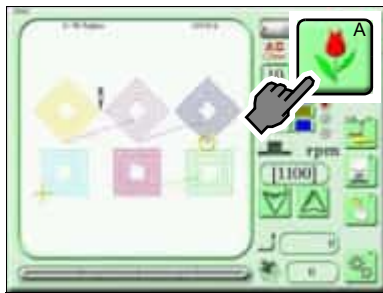

(2) Design

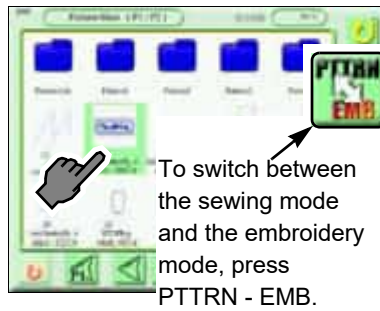

(3) Icon D

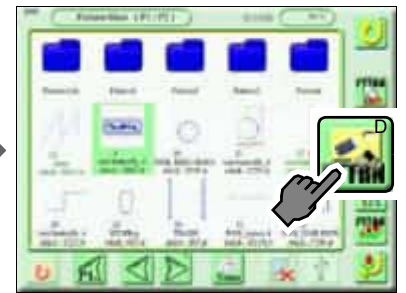

(4) To set

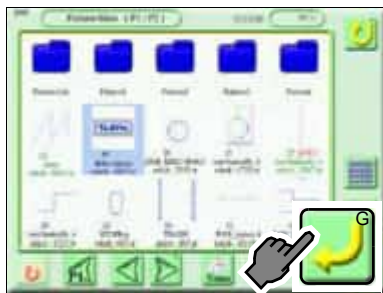

(5) Icon M

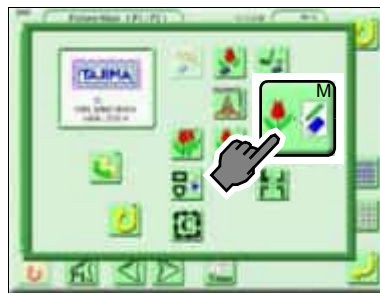

(6) Input 480

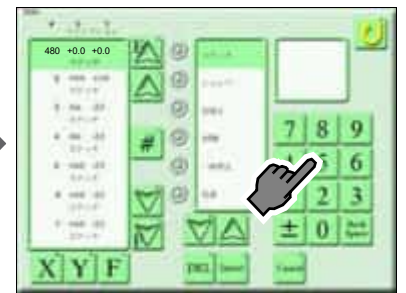

(7) Icon j (Completed)

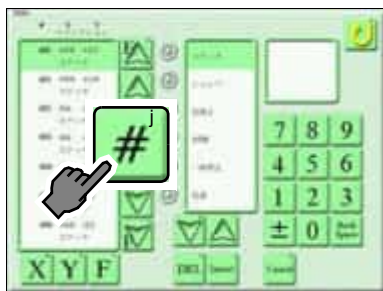

3-2. To specify function code and search stitch

Correspondent function code to the machine and the movement are as shown in the chart below.

Function Code	Movement	Detail
Stitch	Stitches will be sewn.	
Jump	Jumping will be performed. (Frame travel without needle locating)	
Color Change	Stop by color change will be performed.	
ATH	Upper thread or upper/under threads will be trimmed automatically. ^[1]	Upper thread, upper/under threads
Temporary stop	Temporary stop will be performed at stitch or jump.	Stitch, jump
Low speed	A low speed operation will be performed at specified stitch block.	Start S, end S
	A low speed operation will be performed at specified jump block.	Start J, end J
Satin Stitch	Satin stitch conversion will be performed at specified block.	Start, end
Automatic Free-Setting Offset	Frame travel will be performed according to the setting of automatic offset.	
Sequin	Sequin device will work at specified block.	Start, end, output 1, output 2
Boring	Boring will be performed at specified block.	Start, end

[1]This machine trims upper/under threads even if "Upper thread" is selected.

[An example of operation]

Search the jump code and the color change code.

(1) Icon A

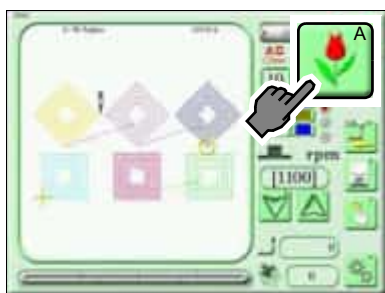

(2) Design

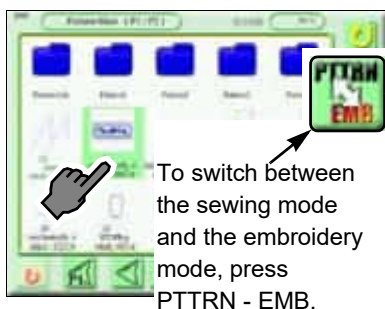

(3) Icon D

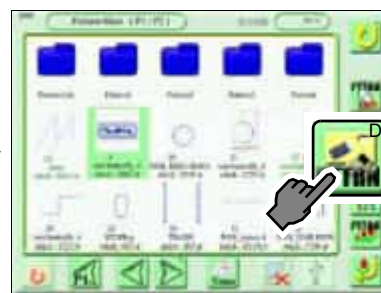

(4) To set

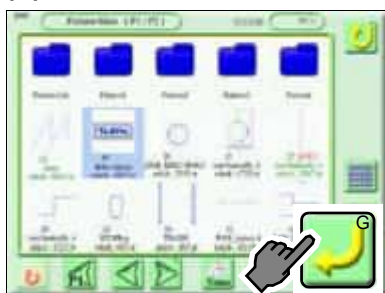

(5) Icon M



(6) Jump, color change

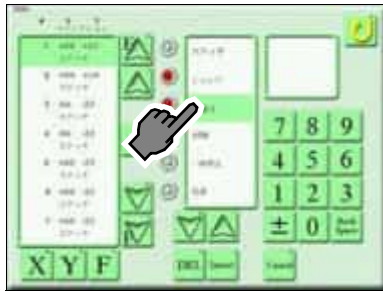

Selected item will be displayed as shown below.



(7) Icon h, or Icon l (Completed)

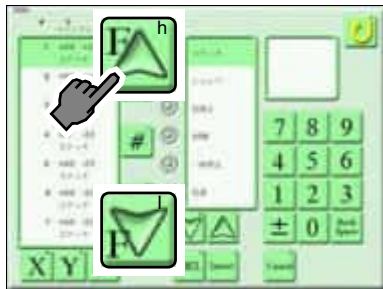

Stitches before the selected stitch will be searched.



Stitches after the selected stitch will be searched.

3-3. To insert a stitch (Input of the password is necessary)

The stitch will be inserted before the selected stitch. If a stitch with a length length is inserted, a design will be displaced hereafter.

To use this function, it is necessary to set the functional limit level to "SEL" by inputting a password. (→p.232, p.229)

CAUTION

The original design will be overwritten after editing. Back up design data as necessary.

[An example of operation]

Insert non-data ATH (trims upper/under threads) code at 480th stitch.

(1) Set the functional limit level to "SEL". (→p.232, p.229)

(2) Icon A



(3) Design

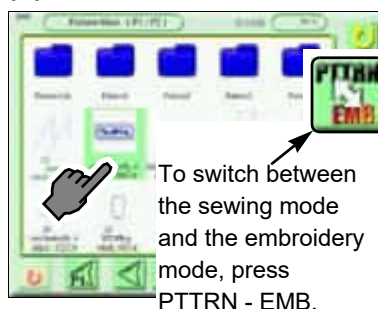

(4) Icon D

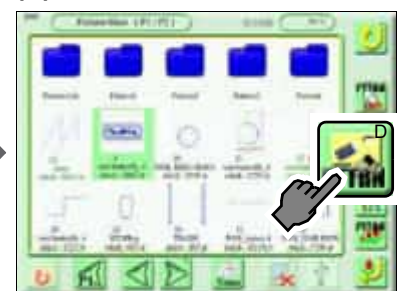

(5) To set

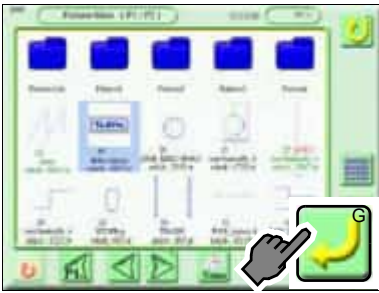

(6) Icon M



(7) Input 480

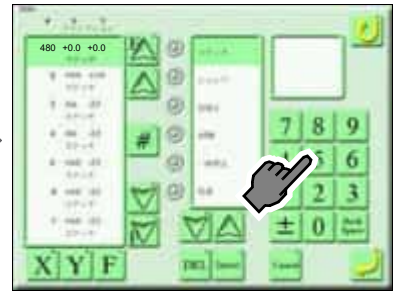

(8) Icon #

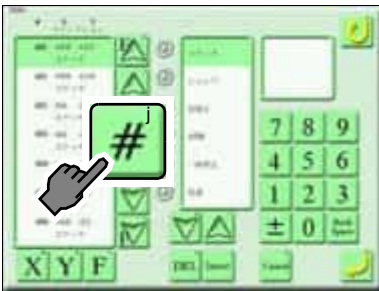

(9) Insert

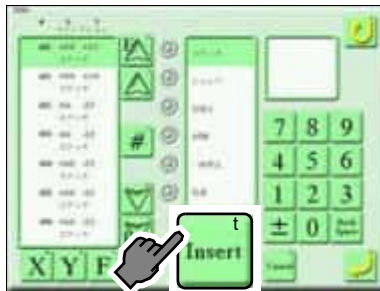

(10) F

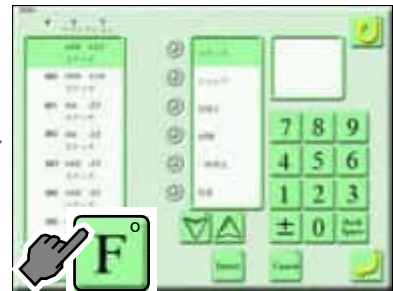

(11) ATH



(12) Upper/under threads



(13) Set (Completed)

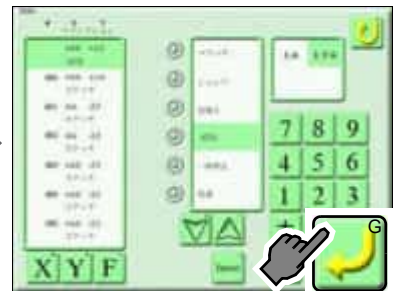

3-4. To delete stitch (Input of the password is necessary)

If the stitch having length is deleted, a design will displace hereafter.

To use this function, it is necessary to set the functional limit level to "SEL" by inputting a password.

(→p.232, p.229)

 **CAUTION**

 The original design will be overwritten after editing. Back up design data as necessary.

[An example of operation]

Delete 480th stitch.

(1) Set the functional limit level to "SEL". (→p.232, p.229)

(2) Icon A



(3) Design

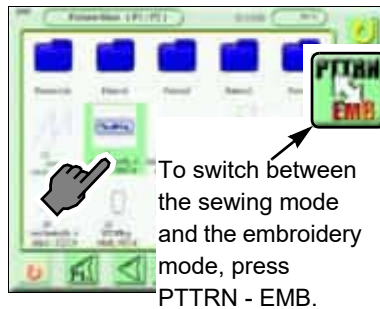

(4) Icon D

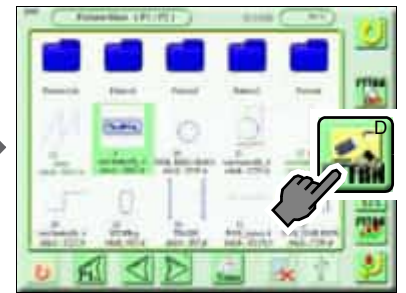

(5) To set

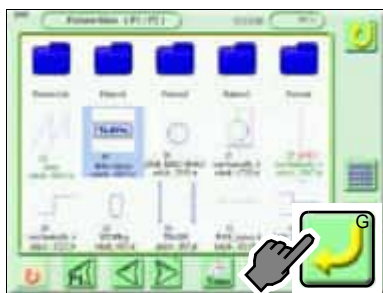

(6) Icon M

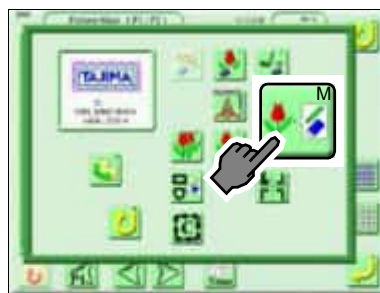

(7) Input 480

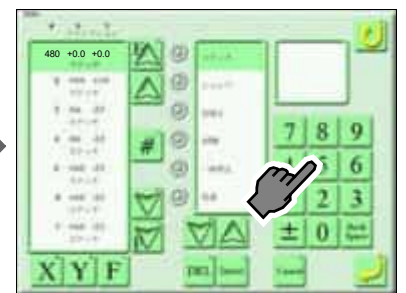

(8) Icon j

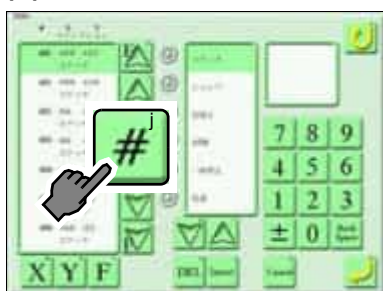

(9) DEL

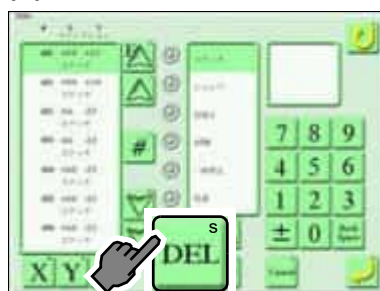

(10) Set (Completed)

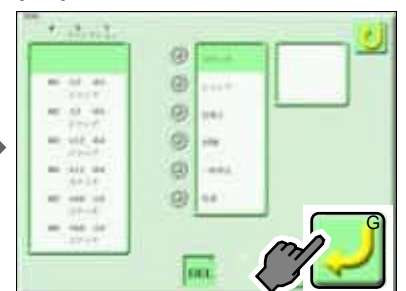

3-5. To modify a stitch (Input of the password is necessary)

If stitch length after change is different from that before change, a design will displace hereafter.

To use this function, it is necessary to set the functional limit level to "SEL" by inputting a password.

(→p.232, p.229)

 **CAUTION**

 The original design will be overwritten after editing. Back up design data as necessary.

[An example of operation]

Change 480th stitch code to jump code.

(1) Set the functional limit level to "SEL". (→p.232, p.229)

(2) Icon A



(3) Design

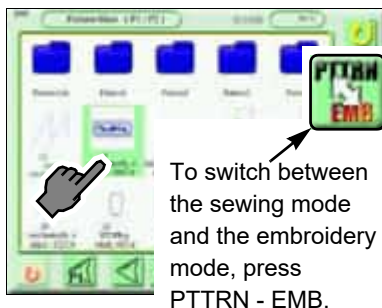

(4) Icon D

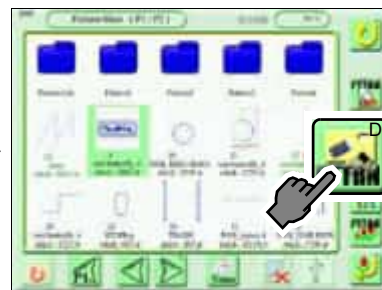

(5) To set

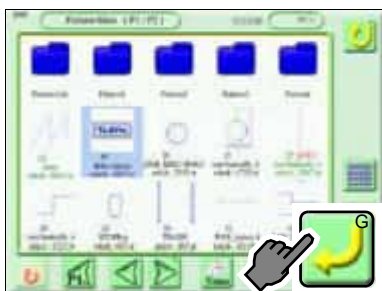

(6) Icon M



(7) Input 480

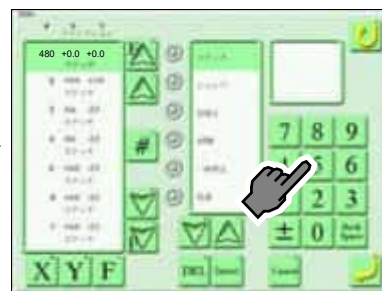

(8) Icon j

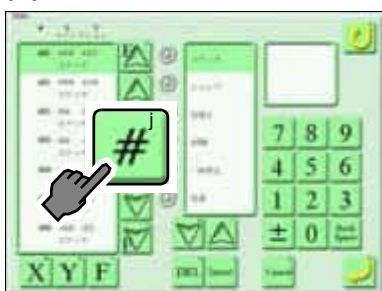

(9) F

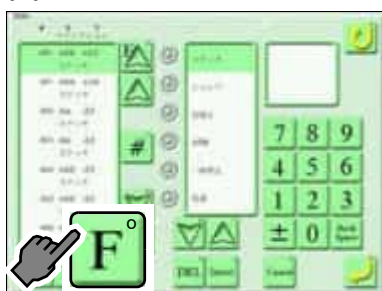

(10) Jump

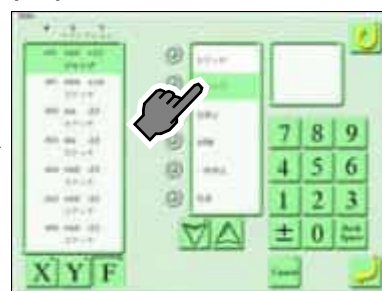

(11) To set (Completed)

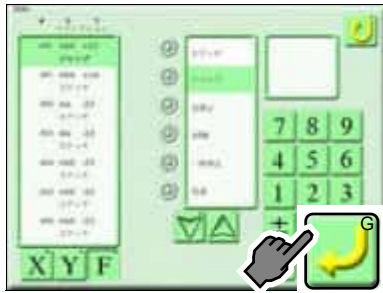

3-6. To delete minute stitch

Minute stitches will be absorbed in before-and after stitches. This function is effective to reduce thread cast-off and thread breakage. It is possible to process designs in the same layer without limit.

CAUTION

The original design will be overwritten after editing. Back up design data as necessary.

[An example of operation]

Select two designs and remove 0.5 mm or less of stitch in designs.

(1) Icon A



(2) 1st design

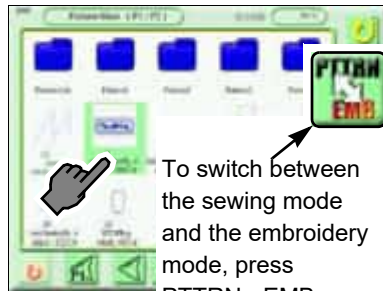

(3) Icon D

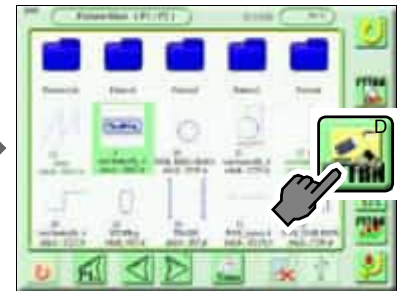

(4) 2nd design

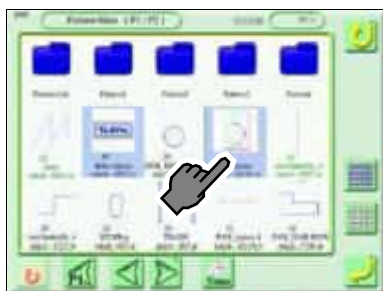

- If this icon is pressed, all designs will be selected.
- If this icon is pressed, selecting the design will be canceled.

(5) To set

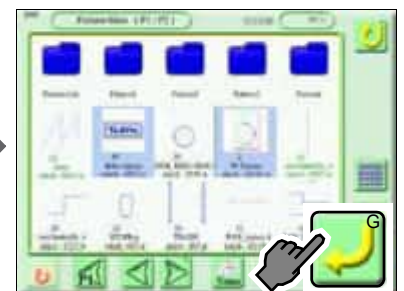

(6) Icon L



(7) 0.5

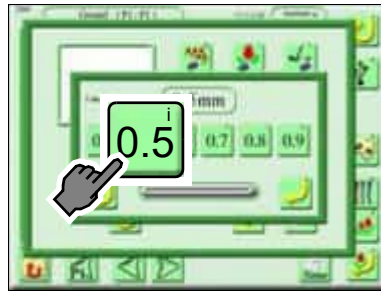

When the selected design is one design, icon b will appear. If you press icon b, the number of removable stitches will be displayed.

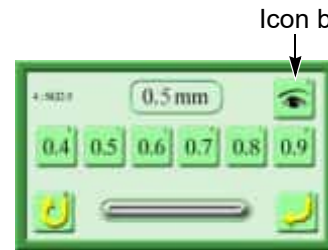

(8) To set

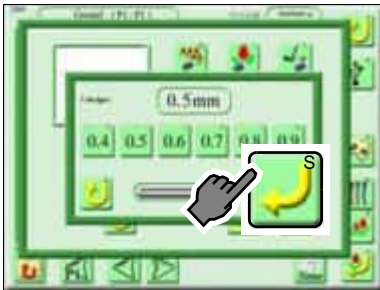

(9) Yes (Completed)



3-7. To set Arbitrary Block

This function can be used only for sewing design.

This function will apply the maximum r.p.m. and the movement of the presser foot to the desired block in the sewing design. It is possible to make up to eight blocks (eight patterns) as the maximum.

For items overlapping with the setting value of the machine parameter or step unit setting value, the value here will take the priority.

[Setting screen]

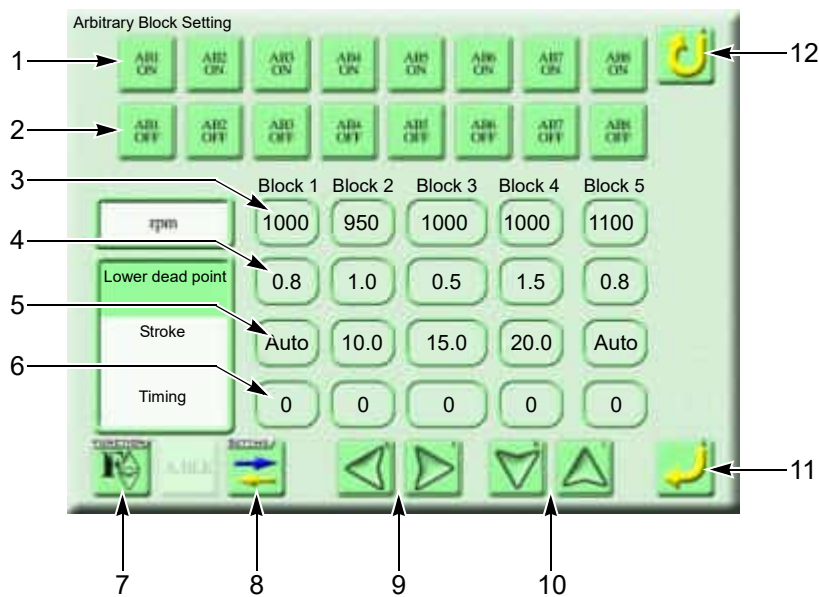

1. Set the start point of the block 1.
2. Set the end point of the block 1.
3. Maximum RPM
4. Presser foot lower dead point
5. Presser foot stroke
6. Presser foot timing
7. Switch to the function setting screen.
8. Perform setting of Frame Back and Frame Forward.
9. Select the block.
10. Select the value. The value of the block at the center can be changed. (Block 3 in this example)
11. Decide the value.
12. Return to the previous screen.

[Setting example]

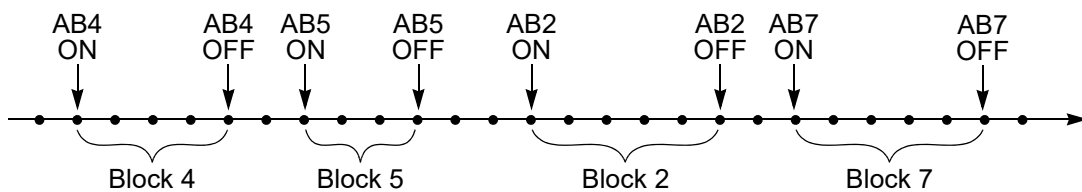

CAUTION

⊘ When performing this operation, do not put your hands, etc. on the table. Moving the frame could injure you.

[An example of operation]

The following conditions will be applied against "Block 2".

Maximum RPM: 1100 rpm

Presser foot lower dead point: 1.0 mm

Presser foot stroke: 10.0 mm

Presser foot timing: 0

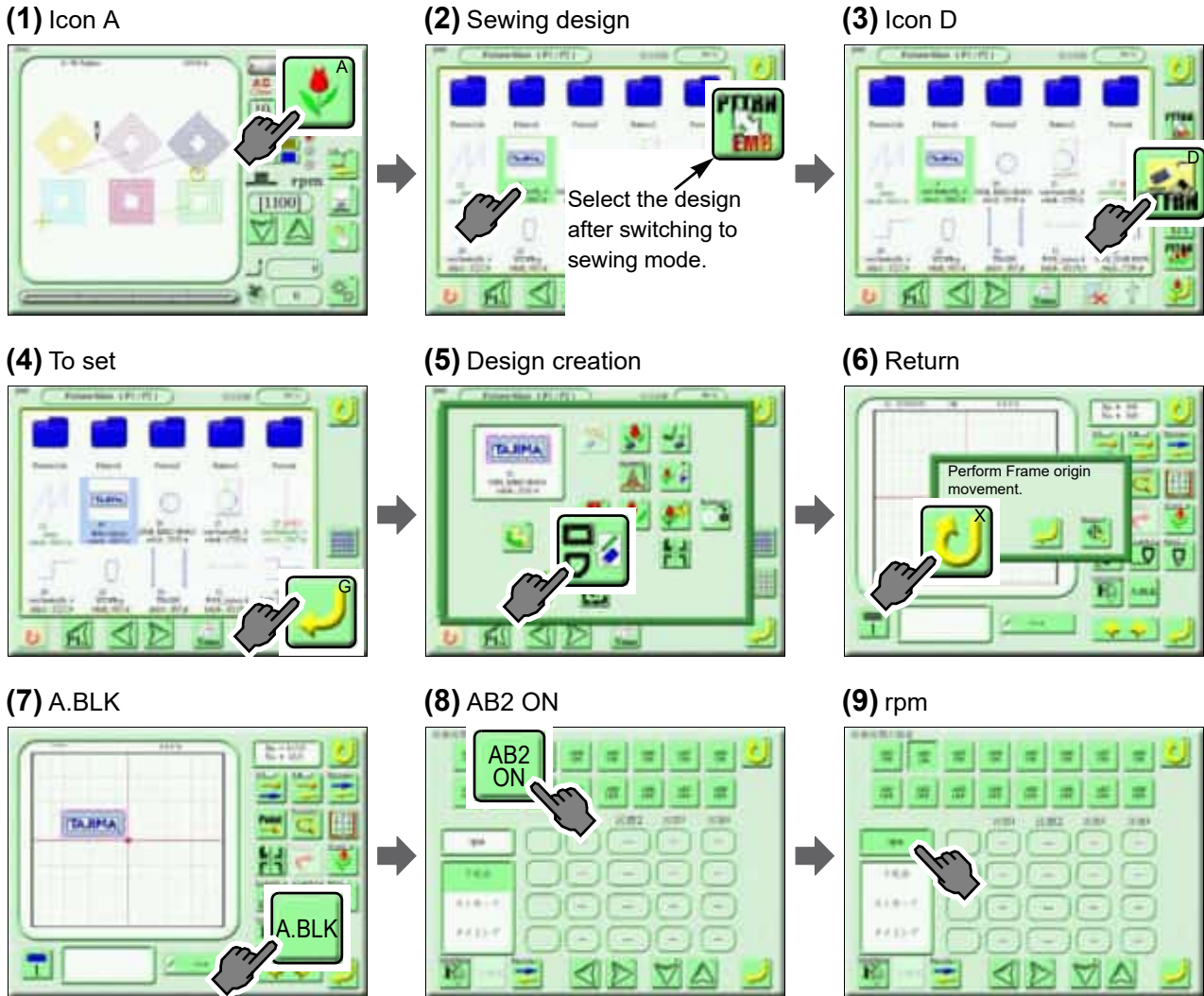

(10) 1100



(11) Lower dead point



(12) 1.0



(13) Stroke



(14) 10.0



(15) Timing



(16) 0



(17) To set (Completed)



[An example of operation]

Set the arbitrary block by the frame travel of Frame Forward, and apply the condition of "Block 2" described above.

(1) Frame Travel

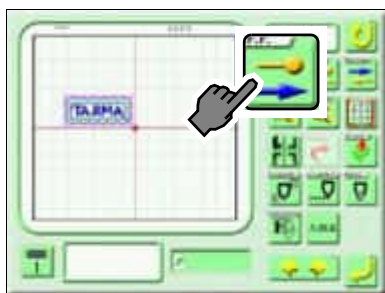

Move the frame to the start point of the block.

Start point

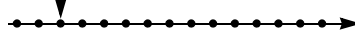

(2) A.BLK

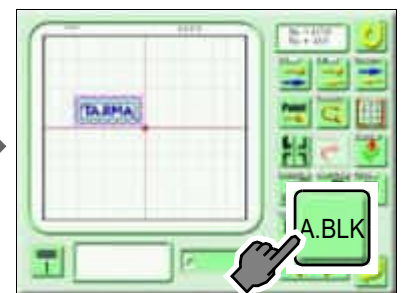

(3) AB2 ON

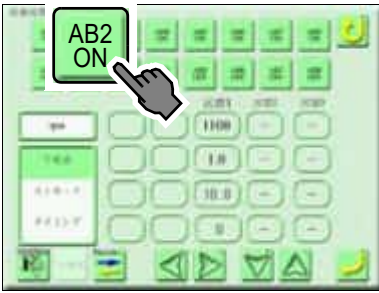

(4) To set



(5) Frame Travel

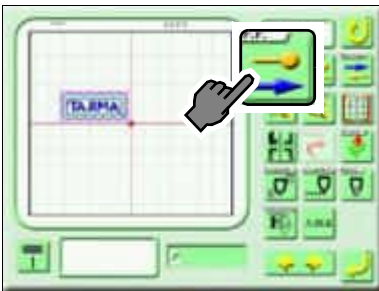

Move the frame to the end point of the block.

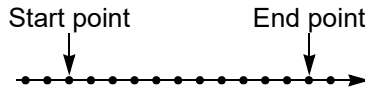

(6) A.BLK

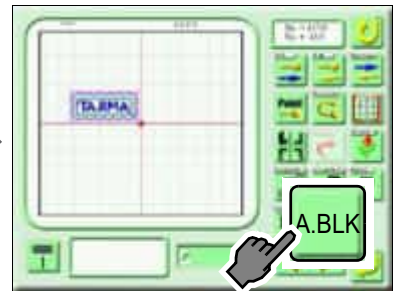

(7) AB2 OFF

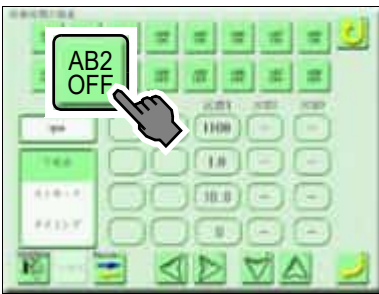

(8) To set (Completed)

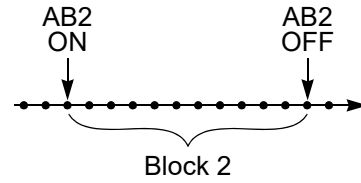

[An example of operation]

Specify the stitch No. (10th stitch as starting point, 25th stitch as ending point) and set the arbitrary block, then apply the condition of "Block 2" described above.

(1) FUNCTION

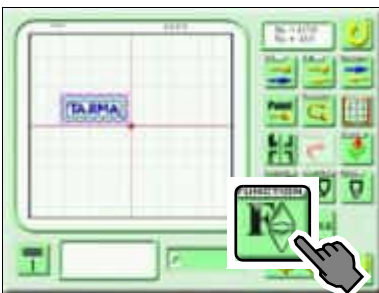

(2) Icon e



(3) 10th stitch



(4) A.BLK

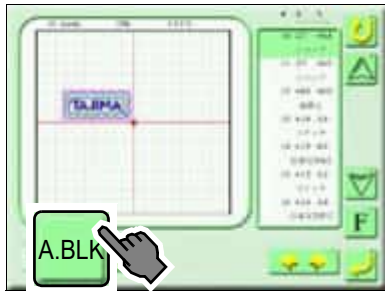

(5) AB2 ON

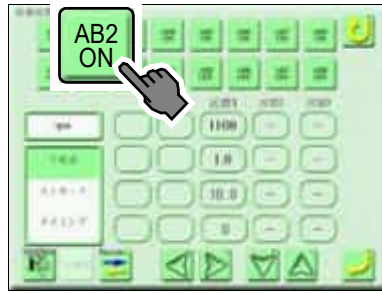

(6) FUNCTION



(7) Yes

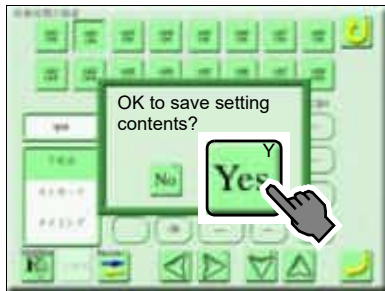

(8) Icon e

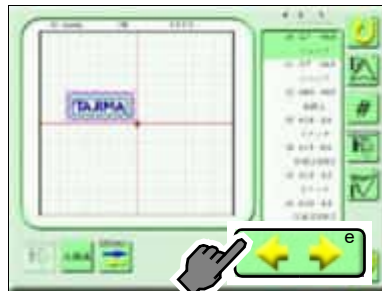

(9) 25th stitch



(10) A.BLK

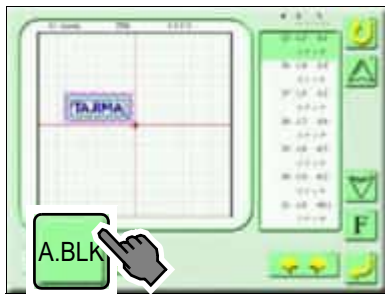

(11) AB2 OFF



(12) To set (Completed)

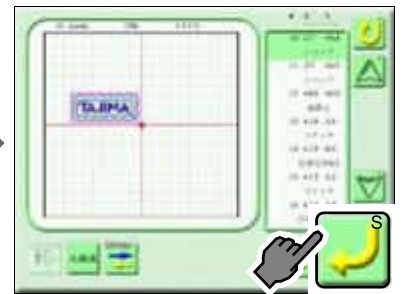

3-8. To make new start point (Jump Feed of Work Point)

Make new start position in the sewing design.

It is possible to make S2 between S1 and the first sewing point (broken line part in the figure below).

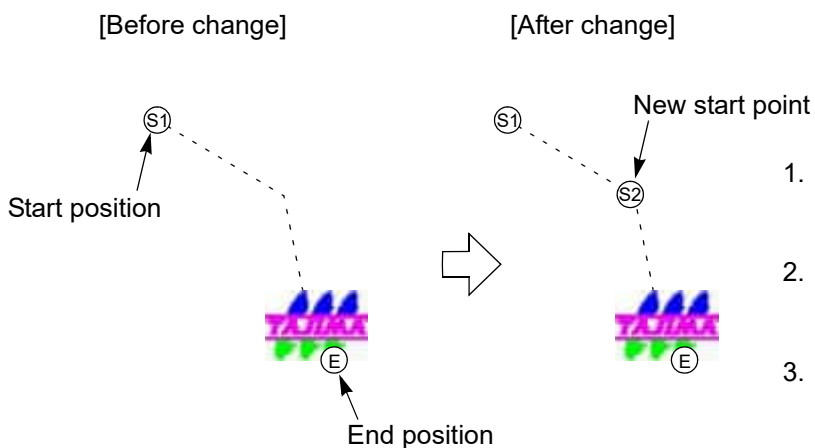

1. After setting data, the frame will move to S1.
2. The machine will move to S2 by Jump Feed after starting, then stop.
3. The machine will work from S2 to E after starting, and the frame will move to S2. After that, the machine will work between S2 and E.

! CAUTION

- ! Previous design will be overwritten by this operation. Back up the design as necessary.
- ⊘ When performing this operation, do not put your hands etc. on the machine table. Moving the frame could injure you.

[An example of operation]

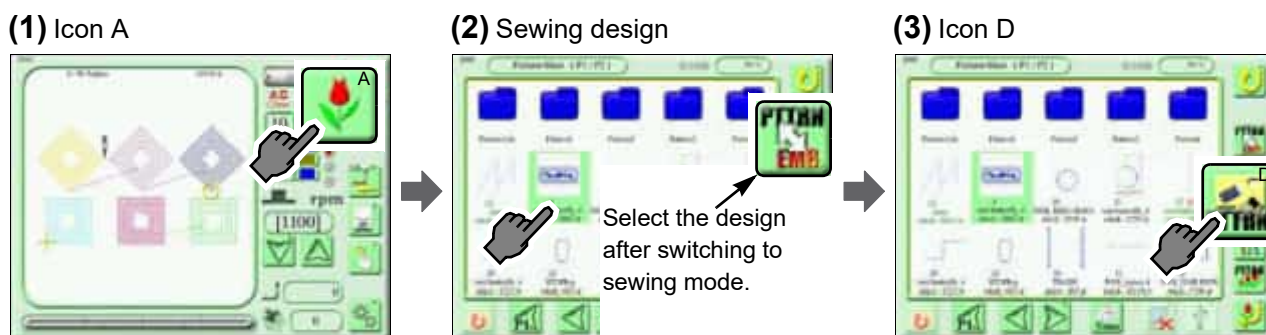

(4) To set

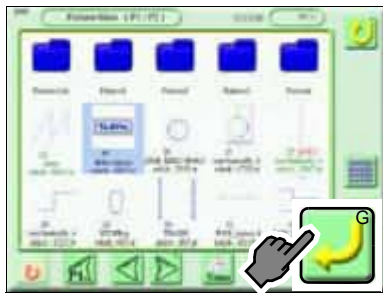

(5) Design creation



(6) To set

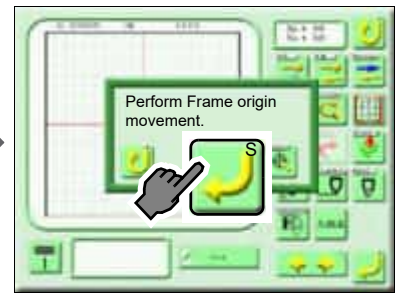

(7) Frame Travel

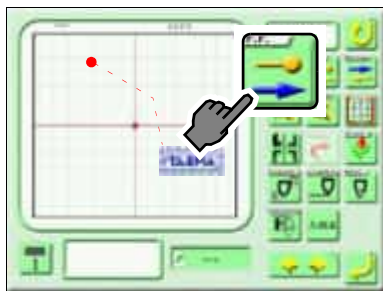

Perform frame travel to the new start point.



(8) J.F.OF.W.P.

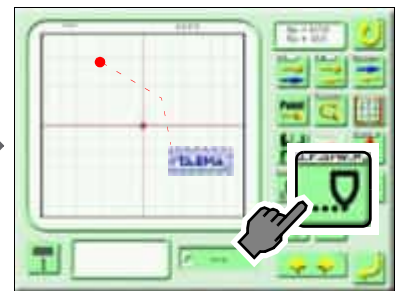

(9) Jump Feed of Work Point



(10) To set (Completed)



3-9. To move sewing position

Move the design based on the current start point, and change the sewing position. The moved distance will be Jump Feed.

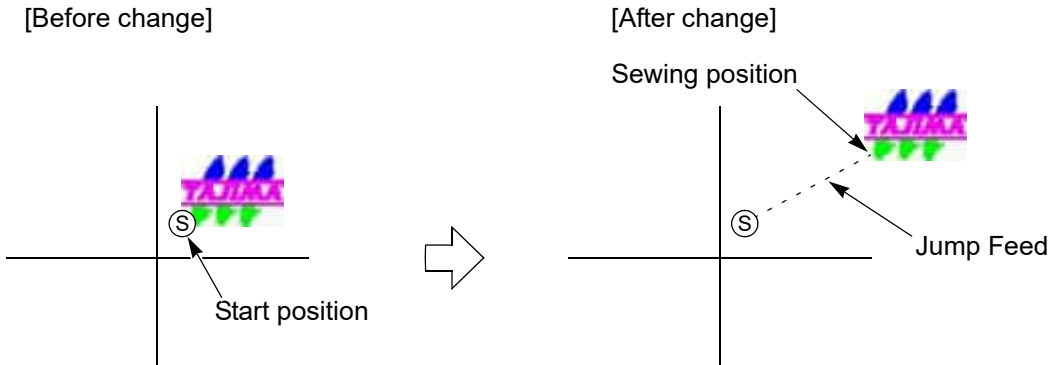

CAUTION

- ❗ Previous design will be overwritten by this operation. Back up the design as necessary.
- 🚫 When performing this operation, do not put your hands etc. on the machine table. Moving the frame could injure you.

[An example of operation]

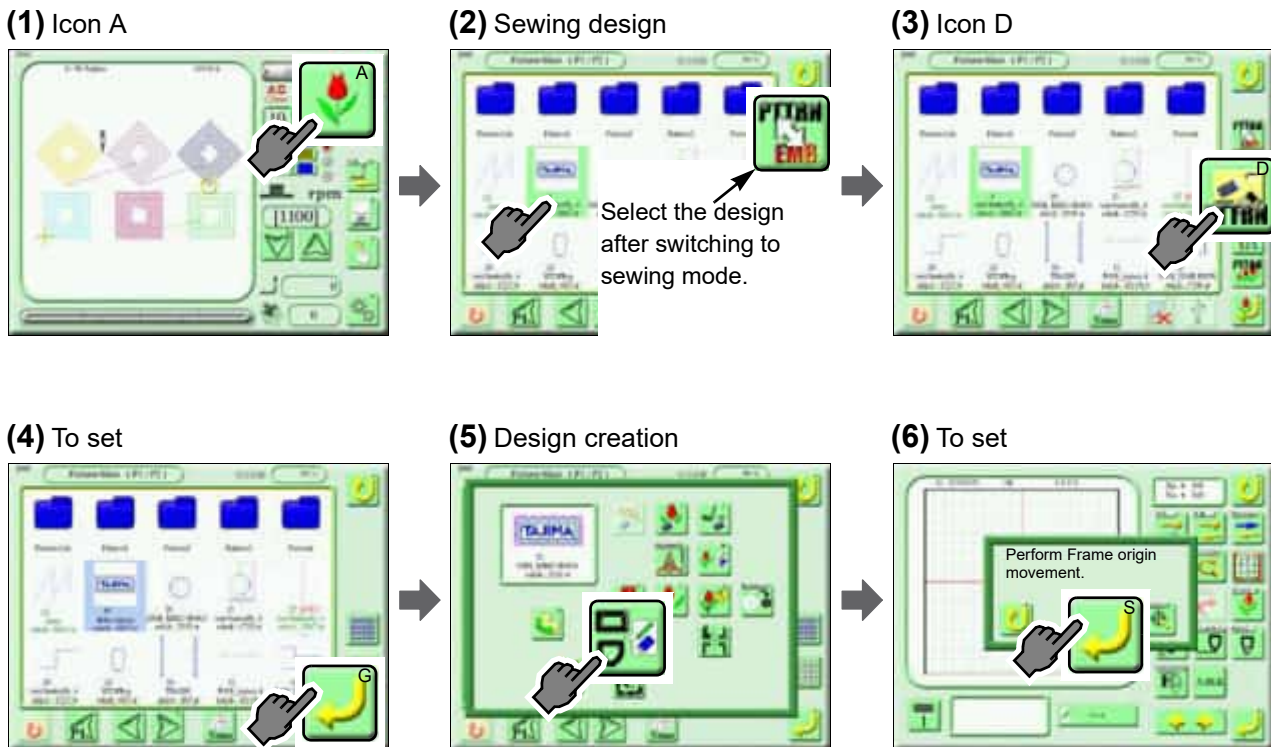

(7) Frame Travel

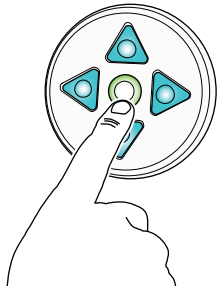

Perform frame travel to the sewing position.

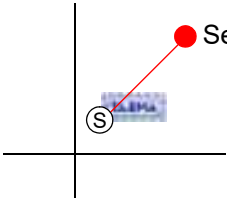

(8) MOVE

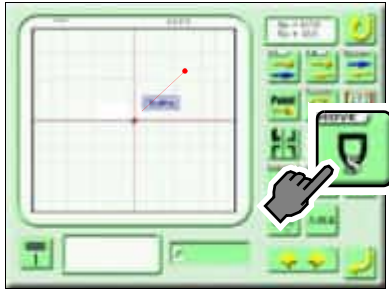

(9) Moving sewing position

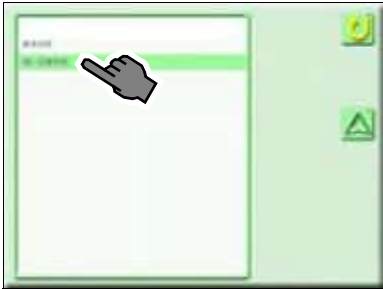

(10) To set (Completed)



4. To copy, to divide and to combine design

The design saved in the machine memory is targeted.

4-1. To copy design

It is possible to copy designs in the same layer without limit.

[An example of operation]

Select two designs and copy them into "Pattern 1" of the machine memory.

(1) Icon A

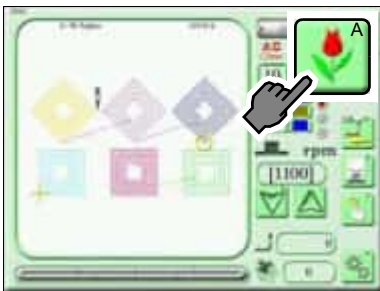

(2) 1st design

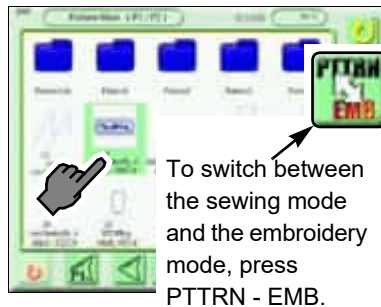

(3) Icon D

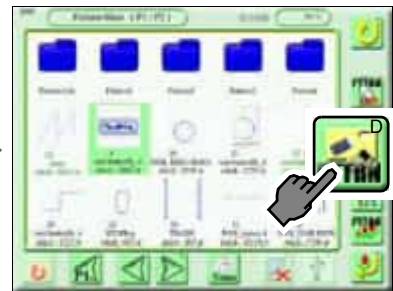

(4) 2nd design

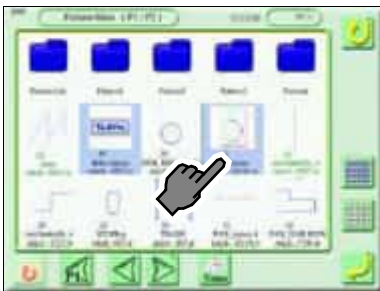

If this icon is pressed, all designs will be selected.



If this icon is pressed, selecting the design will be canceled.

(5) To set

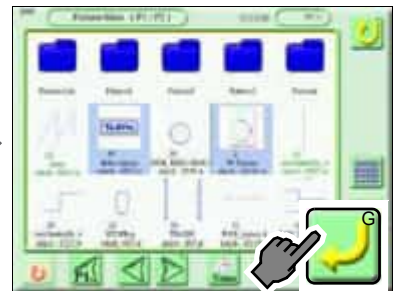

(6) Icon N

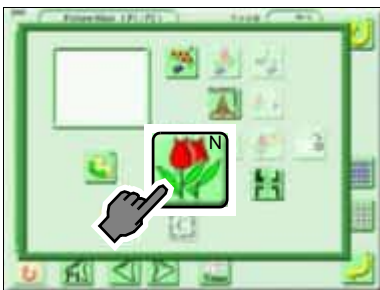

(7) Pattern 1 (Completed)

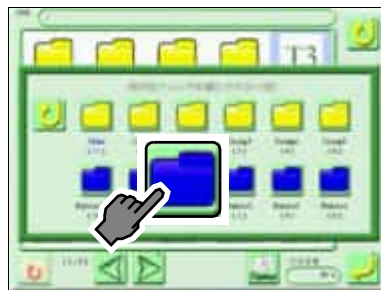

4-2. To divide design

Divide the design by the color change code of a design.

CAUTION

 Previous design will be divided by this operation. Back up the design as necessary.

[An example of operation]

(1) Icon A

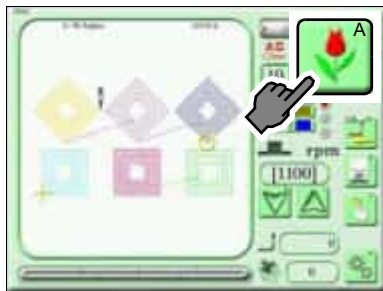

(2) Design

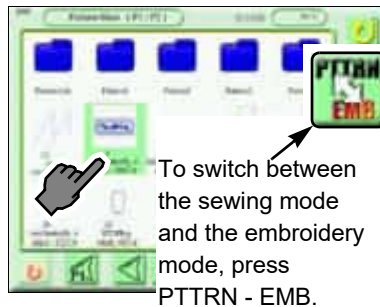

(3) Icon D

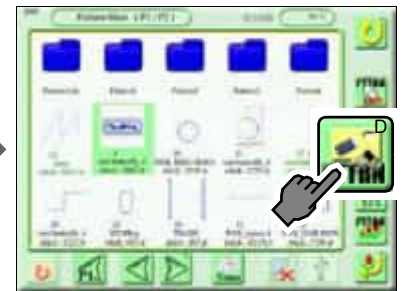

(4) To set

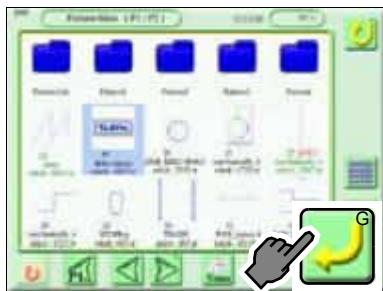

(5) Icon O



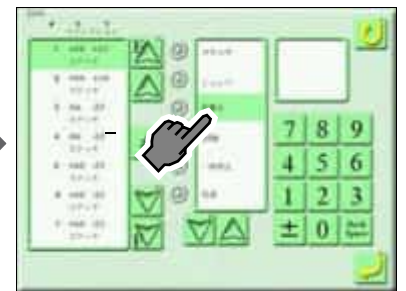

(6) Color Change

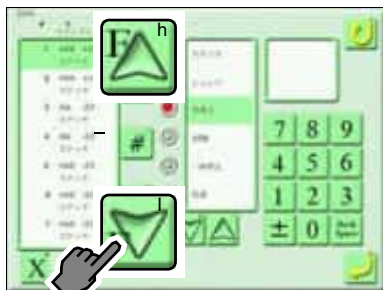

(7) Icon h, or Icon l



 Stitches before the selected stitch will be searched.

 Stitches after the selected stitch will be searched.

Search the color change code. The specified color change code will become the dividing point.

(8) To set

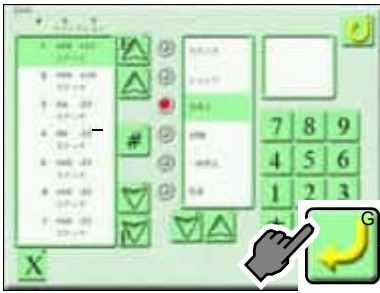

(9) Yes (Completed)

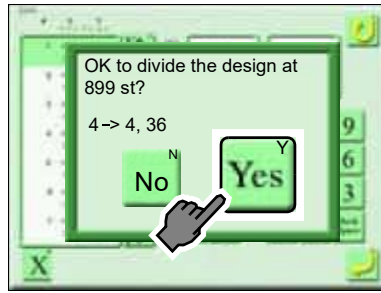

The design of a memory No. 4 will be divided to a memory No. 4 and that No. 36 and saved in a example shown left.

4-3. To combine design

If plural embroidery designs are combined, they will be saved into "Sewing mode screen" of the machine memory as one design.

If plural sewing designs are combined, they will be saved into "Sewing mode screen" of the machine memory as one design.

[An example of operation]

Combine two embroidery designs.

(1) Icon A



(2) 1st design (Embroidery design)

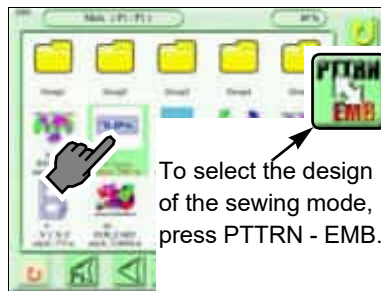

(3) Icon D

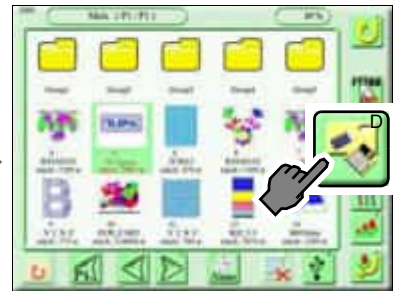

(4) To set



(5) Icon P



(6) Icon E



(7) 2nd design

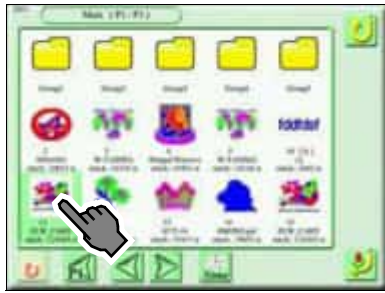

(8) To set



(9) 1st design



When deleting 2nd design, press "DEL" key with selecting 2nd design.
To copy a design, press "Insert" key while selecting a design.

(10) Icon F



(11) Start position



Input X/Y coordinates of the start position with numerical key.

(12) To set



(13) 2nd design



(14) Icon F



(15) Start position



(16) To set

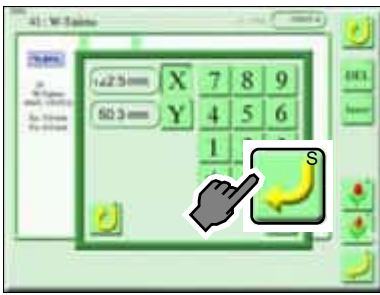

(17) To set (Completed)



[An example of operation]

Combine three embroidery designs.

(1) Icon A



(2) 1st design (Embroidery design)



(3) Icon D

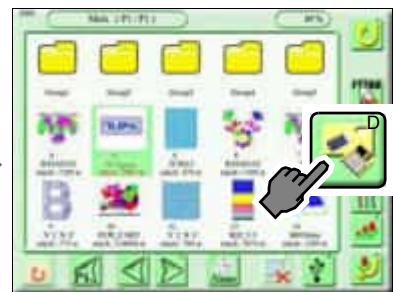

(4) To set



(5) Icon P



(6) Icon E

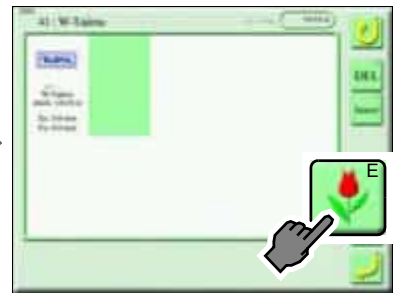

(7) 2nd design

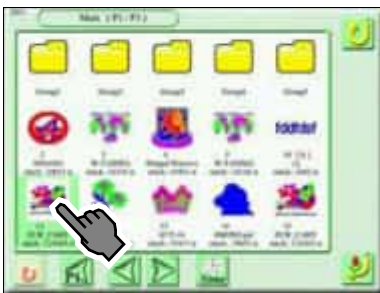

(8) To set



(9) Space of 3rd design



(10)Icon E

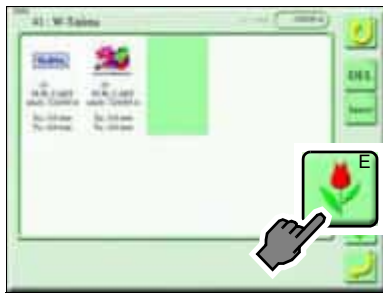

(11)3rd design

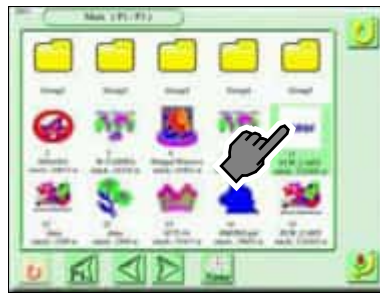

(12)To set

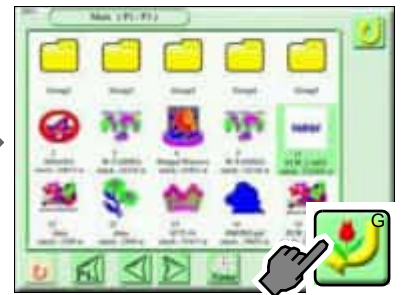

(13)To set (Completed)



(14)After that, decide the start position of each design. (→p.161)

4-4. To sew sewing design and embroidery design in combination

It is possible to sew the sewing design and the embroidery design continuously like one design in combination. The combined design will be saved into "Pattern-List" of the machine memory.

[Design combination screen]

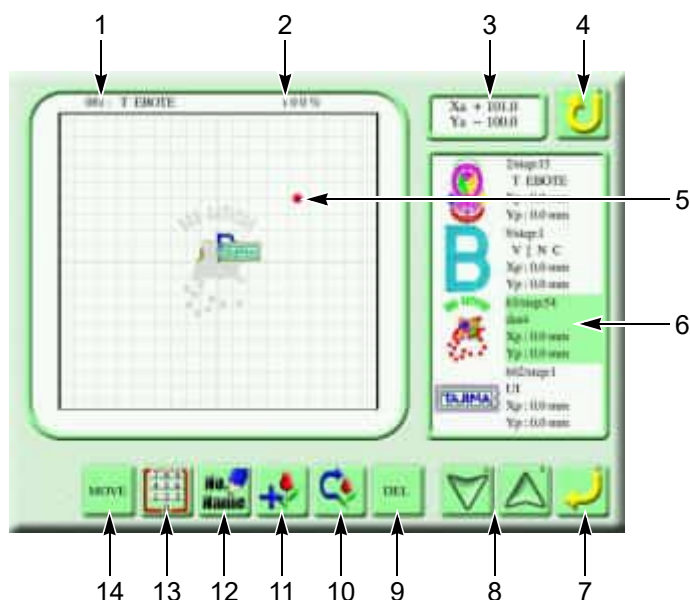

1. Design No., Design Name
2. Current scale ratio
3. Coordinates display
Every time pressing this part will switch the display.
Xa, Ya: Coordinates based on the frame origin
Xp, Yp: Coordinates based on the design start point of the 1st design
4. Return to the previous screen.
5. Current frame position
6. Combined designs are displayed on the list column. (Up to 4 designs)
7. Decide contents.
8. Select a design.
9. Delete the design from the list column.
10. Change the order of the design. After selecting the design, press this icon. After that, select the design positioned under the design you want to change the order by the up/down icon, then press SET key.
11. Add the design to the list column.
12. Perform setting of the design No. and the design name.
13. Perform frame travel by inputting value with numerical keys.
14. Register the current frame position at the design start position of the design being selected.

[An example of operation]

Combine two designs (Sewing design and Embroidery design).

(1) Icon A

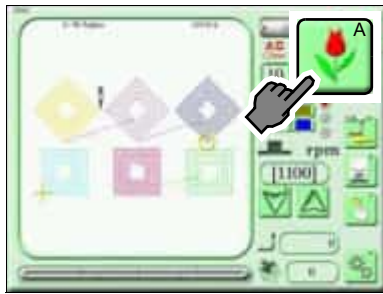

(2) 1st design (Sewing design)^[1]

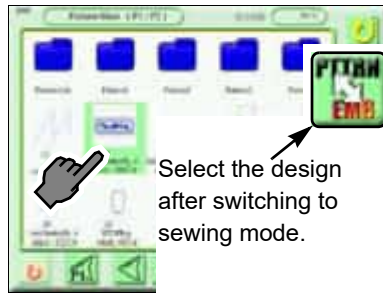

(3) Icon D

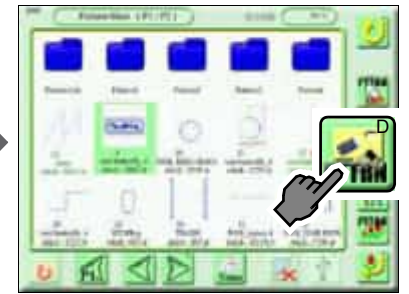

[1]Sewing design only can be selected for the 1st design.

(4) To set

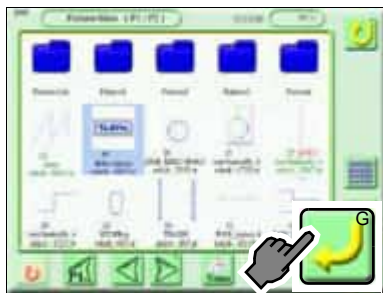

(5) Icon C

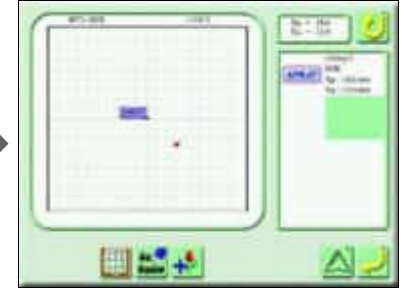

(6) To perform frame travel to start point

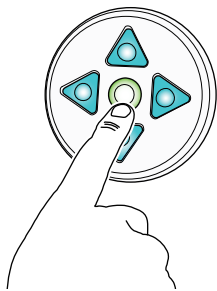

Perform frame travel to the design start point of the 2nd design.

(7) Adding design



(8) PTTRN

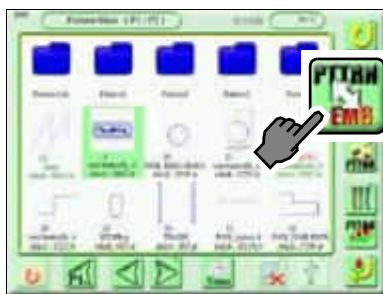

(9) 2nd design (Embroidery design)



(10) To set

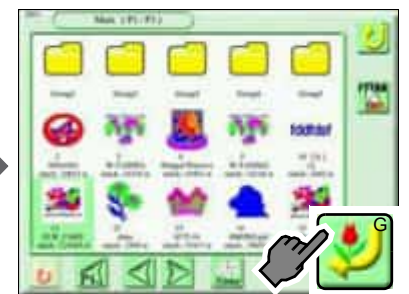

(11)MOVE

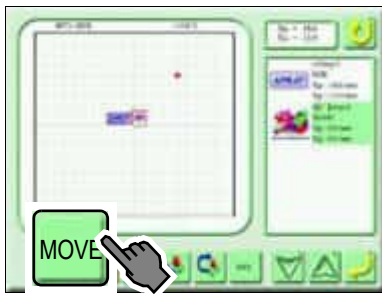

(12)To set

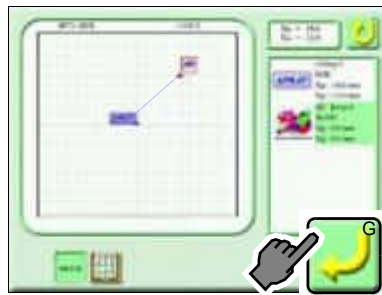

(13)To set

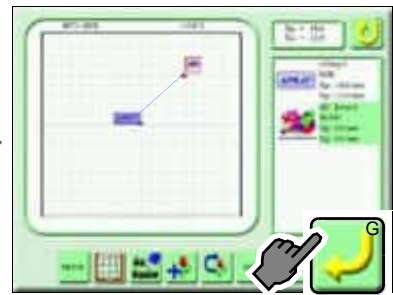

(14)Yes (Completed)

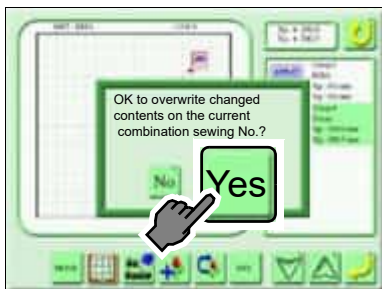

4-5. To change direction of sewing design and save it into machine memory

This function can be used only for sewing design.

[Setting screen]

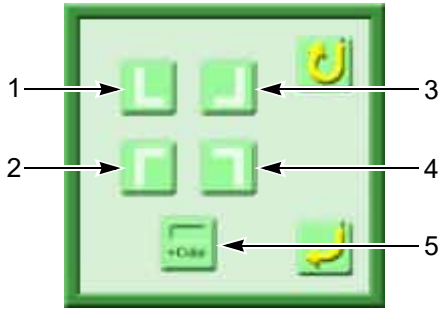

1. Copy the design with leaving the previous design.
2. Change the direction based on X-axis.
3. Change the direction based on Y-axis.
4. Rotate by 180°
5. Add the color change code for each copied design.

An example of selection	After conversion	Remarks
		Based on Y-axis
		Based on X-axis
		180° rotation
		Copy the design with leaving the previous design.

[An example of operation]

Change the direction of the sewing design, and save it into "Pattern 1" of the machine memory.

(1) Icon A

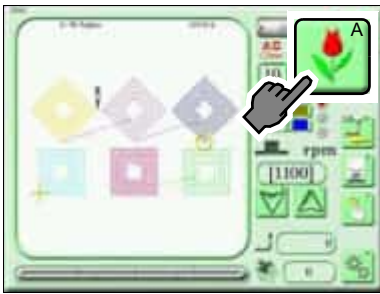

(2) Sewing design

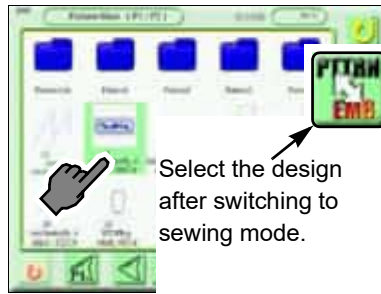

(3) Icon D

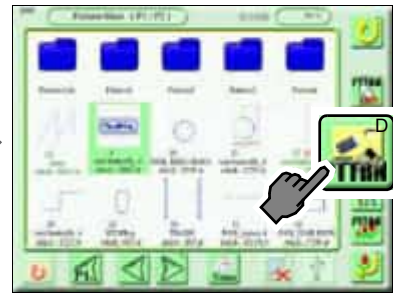

(4) To set

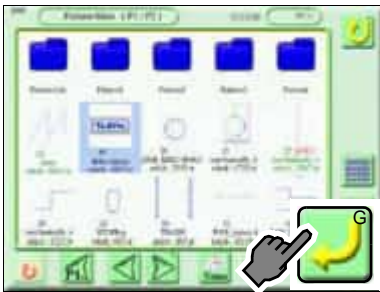

(5) Conversion



(6) Y-axis reversion

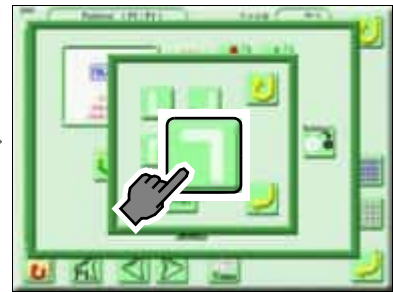

(7) To set



(8) Pattern 1 (Completed)

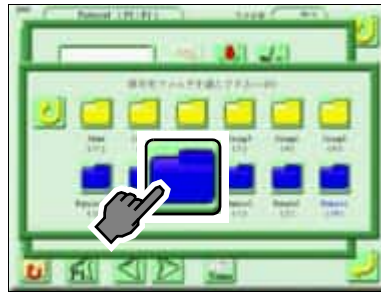

5. To create sewing design

This function can be used only for sewing design.

To use this function, set "Network" (P7-78-1) to "Sidekick [V2]". (→p.281)

5-1. Screen of Design Creation and Design Modification

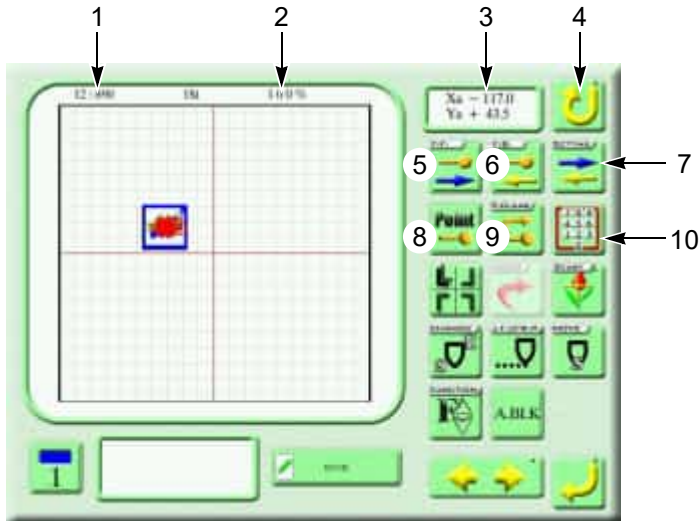

1. Design No., Design Name
2. Current scale ratio
3. Coordinates display
Every time pressing this part will switch the display.
Xa, Ya: Coordinates based on the frame origin
Xp, Yp: Coordinates from the last point
4. Return to the previous screen.
5. Frame Forward when modifying design. When modifying the configuration point, advance the configuration point one by one. In case for modifying the apex, advance the apex one by one.
6. Frame Back when modifying design. When modifying the configuration point, advance the configuration point one by one. In case for modifying the apex, advance the apex one by one.
7. Perform setting of Frame Back or Frame Forward.
8. When creating design, decide the current position as Point. When modifying design, decide the current position as Point to modify.
9. Perform frame travel to the newest point, and cancel the point. If no point, perform frame travel to the selected point.
10. Set the current frame position to "Xm +0.0, Ym +0.0". It is also possible to perform frame travel by inputting value with numerical keys.

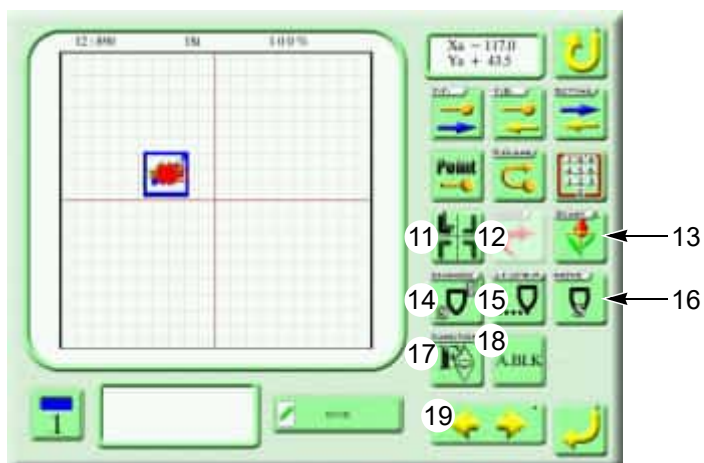

11. Change the design direction base on the start point. After the frame travel, change the design direction based on those coordinates. (→p.167)
12. Cancel the change decided by using "SET" key to restore at the end.
13. Perform frame travel to the start point.
14. Set the current frame position to the start position or the end position.
15. Perform setting of Jump Feed of Work Point. (→p.154)
16. Perform setting of Sewing position movement. (→p.156)
17. Perform setting of the design function to use for the sequence faculty.
18. Perform setting of Arbitrary Block. (→p.149)
19. Switch the screen.

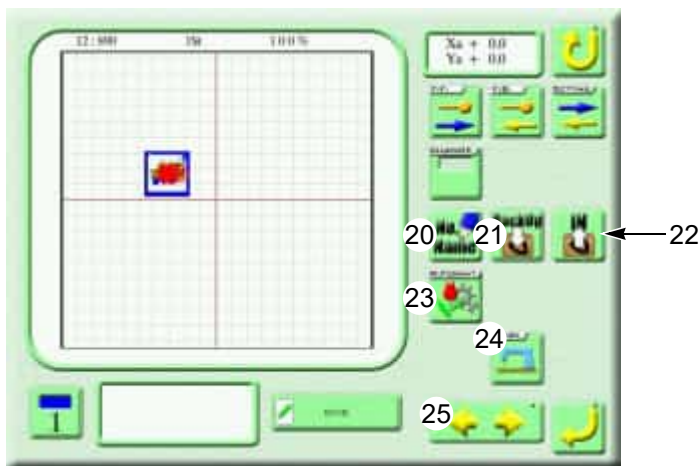

20. Perform setting of the design No. and the design name. (→p.172)
21. Back up the design in the middle of modifying currently.
22. Read the backup design.
23. Perform setting of Machine Formats. (→p.174)
24. Perform test sewing of the design in the middle of creation and modification. (→p.183) The design of the set data will be canceled.
25. Switch the screen.

5-2. Scaling up/down of screen

Every time pressing coordinates area on the operation panel will change the scale factor of coordinates area.

100% → 200% → 400% → 800% → 100%

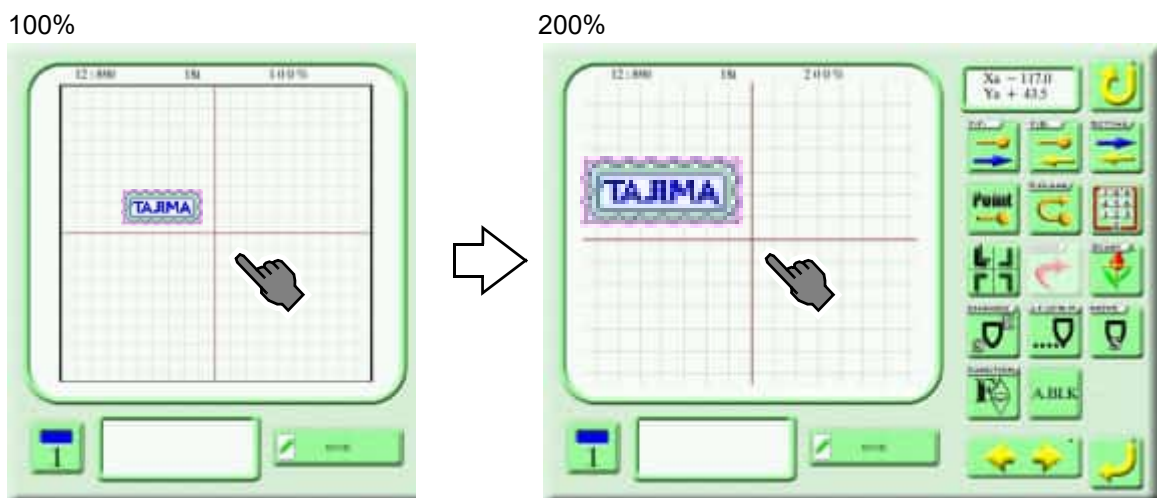

5-3. Setting screen of Design No.

To save the created design into the machine memory, the design No. and the design name is necessary.

[Setting screen of Design Name]

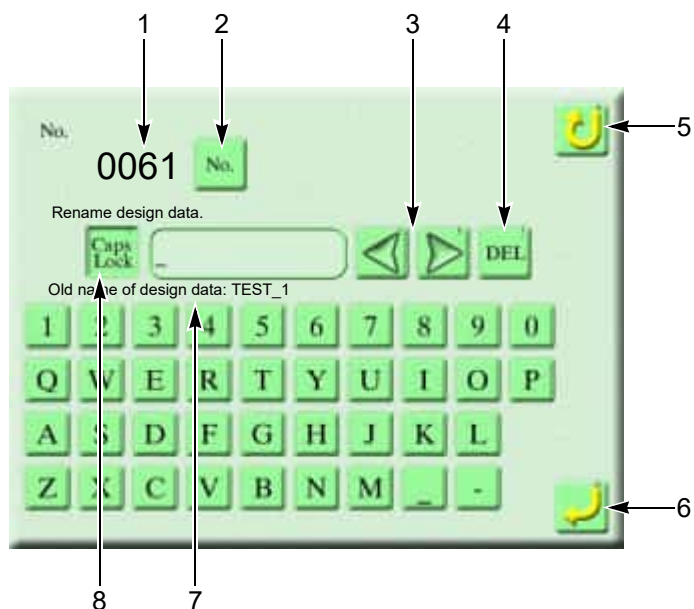

1. Current design No.
2. Obtain the new design No.
3. Move the cursor.
4. Delete a character.
5. Return to the previous screen.
6. Decide the value.
7. Current design name
8. Switch large character/small character.
9. Next free-number
10. Then, a big free-number will be selected.

[Setting screen of Design No.]

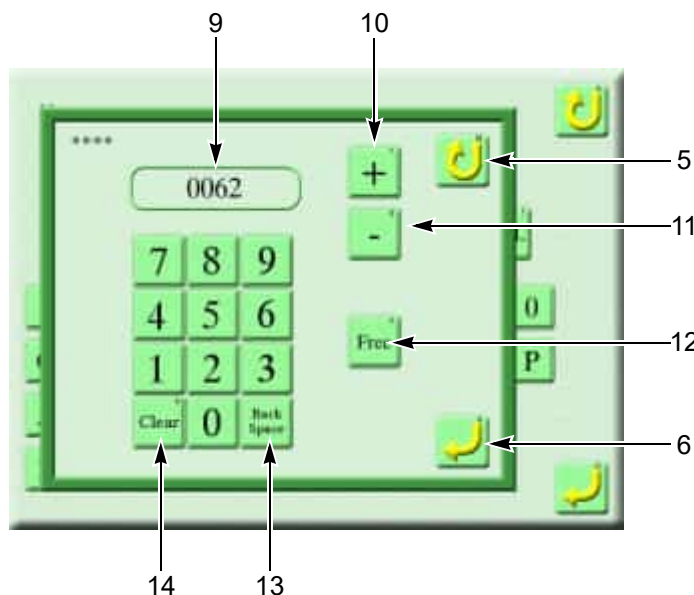

11. Then, a small free-number will be selected.
12. The minimum free number will be selected.
13. Delete a character.
14. Set the value to 0000.

5-4. Sewing mode selection screen

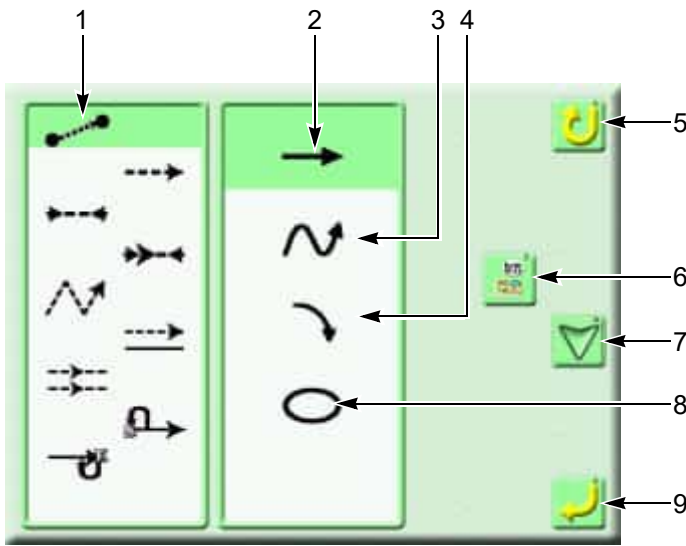

1. Sewing method (→p.61)
2. Straight Line
3. Spline
4. Arc
5. Return to the previous screen.
6. Switch to the selection screen of stitch length.
7. Switch to the design modification function list screen. (→p.74)
8. Circle
9. Decide setting contents.

5-5. Selection screen of stitch length

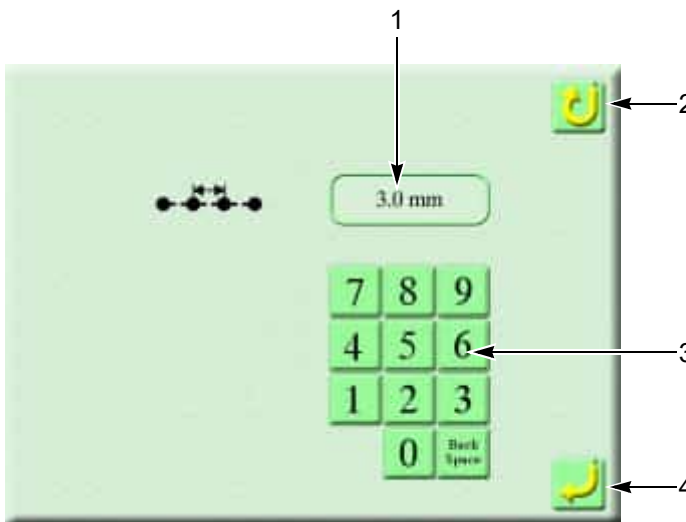

1. Stitch length
2. Return to the previous screen.
3. Input with numerical key
4. Decide the value.

5-6. Machine Format setting screen

Machine Format is the basic setting at creation of design, and it requires setting for each design.

When changing the setting value of Machine Formats in the middle of design creation, stitches will be generated at all segments before that time. Therefore, all settings such as "Arbitrary Block" and "Jump Feed of Work Point" after generating stitches will be deleted.

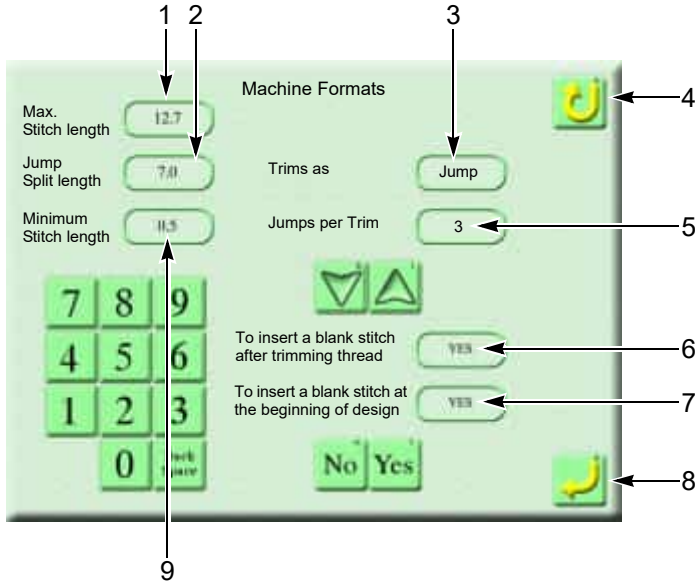

Firstly, touch the number, then change the value.

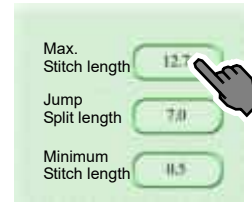

1. "Max. length in unit of axis" of stitch that can be created
Setting range: 0.1 to 12.7 mm / 0.1 mm unit
2. Set how many millimeters of distance for when moving from the stitch part to the stitch part.
Setting range: 0.1 to 12.7 mm / 0.1 mm unit
3. It is not changeable. (Jump only)
4. Return to the design creation screen.
5. When moving from the stitch part to the stitch part, set how many consecutive jump cause thread trimming.
Setting range: 0.1 to 99 stitches
6. Insert a blank stitch after trimming thread.
Setting range: Yes / No
7. Insert a blank stitch at the beginning of design.
Setting range: Yes / No
8. Decide setting contents.
9. Minimum value of stitch that can be created
Setting range: 0.0 to 12.7 mm / 0.1 mm unit
When 0.0 mm is selected, minimum stitch length will be disregarded.
When 0.1 mm or more is selected, stitch of which length is shorter than the value will not be generated.

5-7. To create sewing design



CAUTION

 When performing this operation, do not put your hands, etc. on the table. Moving the frame could injure you.

To use this function, set "Network" (P7-78-1) to "Sidekick [V2]". (→p.281)

[An example of operation]

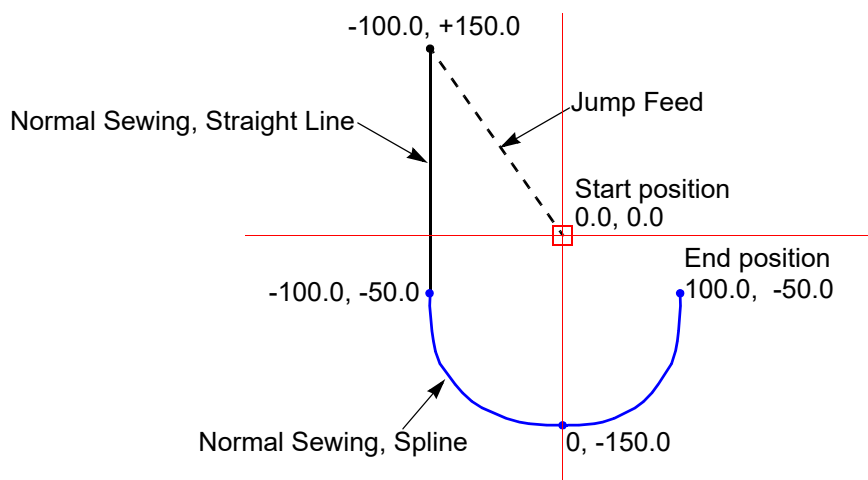
Create the below sewing design and save it into the machine memory.



When SET key is pressed in the middle of creation, Spline is not created. Press "Point" when making Spline.

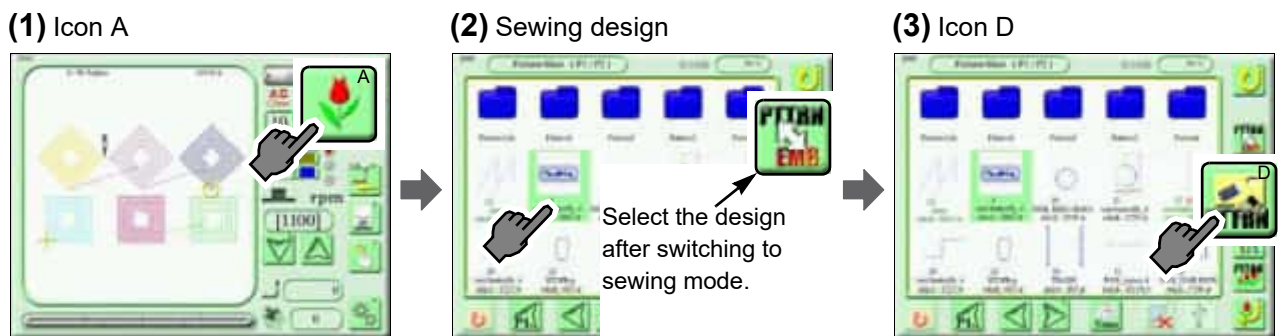

(4) To set

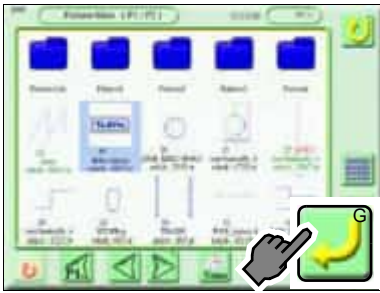

(5) Design creation



(6) To set

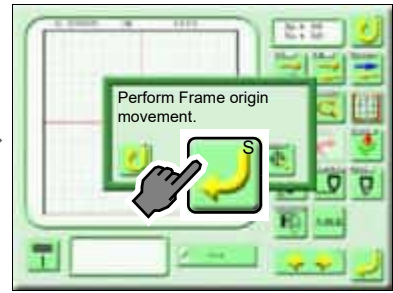

(7) Design creation

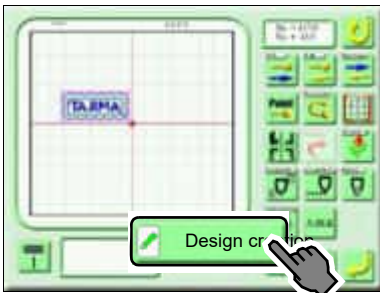

(8) To set Machine Format



Firstly, touch the number, then change the value.
To set Machine Format (→p.174)

(9) To set

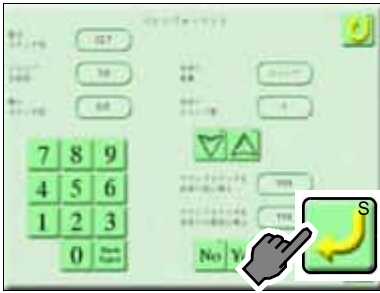

(10) Edit frame

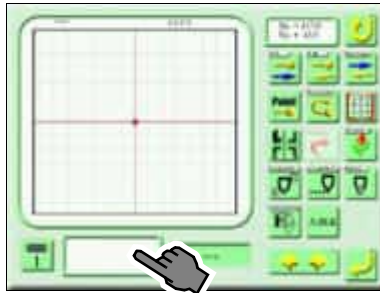

(11) Jump Feed, Straight Line

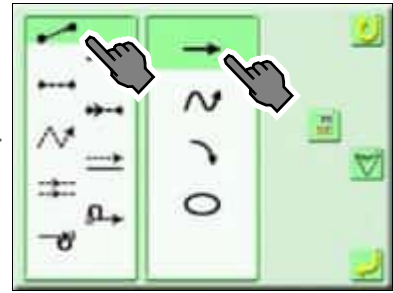

(12) Icon T

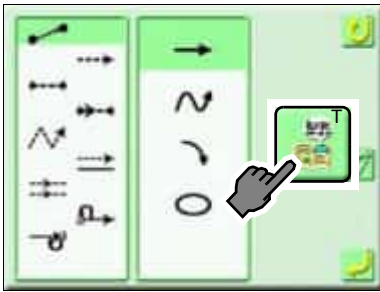

(13) 2.0 (mm)

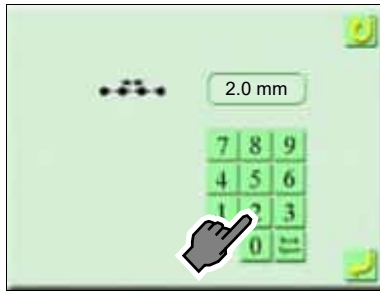

(14) To set

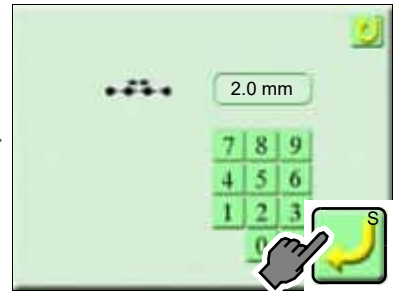

(15) Needle bar selection icon

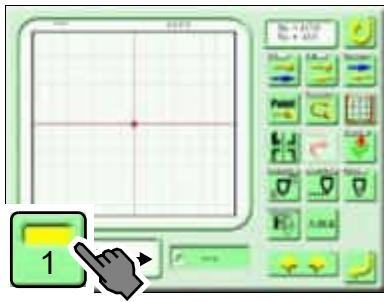

(16) Needle bar No. 4

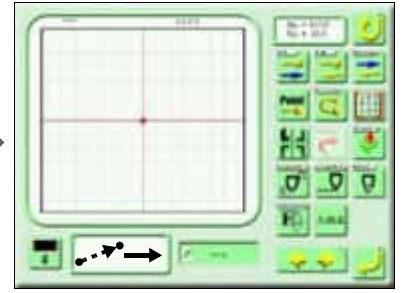
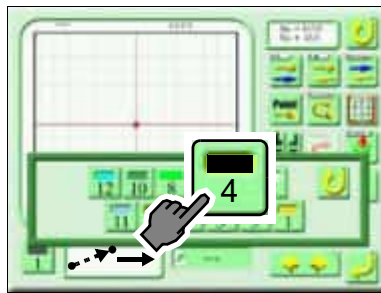

(17) Frame Travel

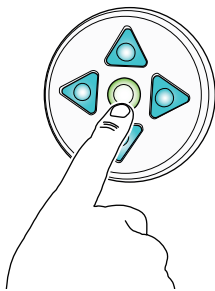

(18) -100.0, +150.0

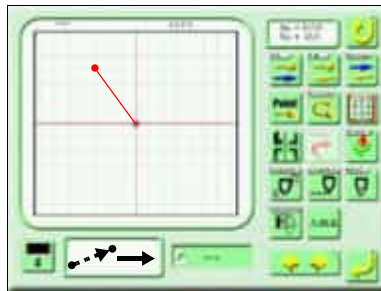

(19) To set

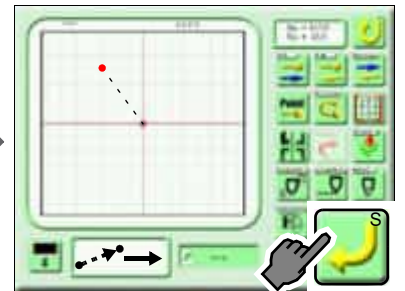

(20) Edit frame

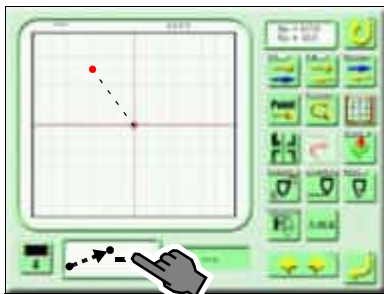

(21) Normal Sewing, Straight

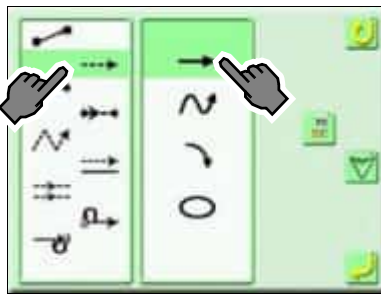

Line

(22) Icon T

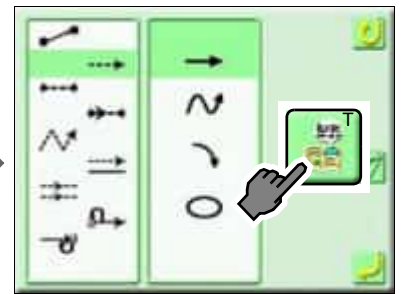

(23) Normal (→p.61)

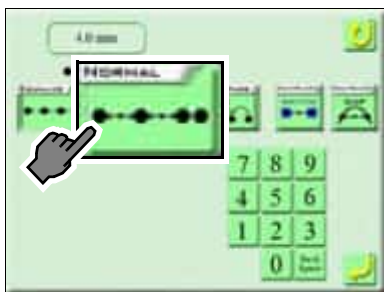

(24) 3.0 (mm)

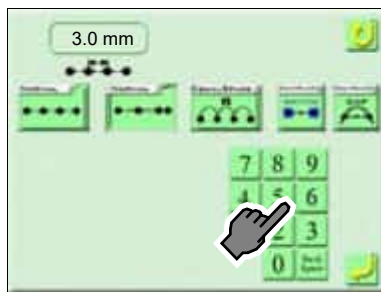

(25) To set

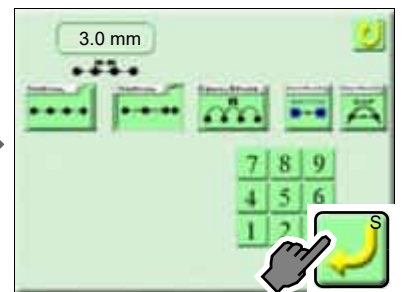

(26)Frame Travel

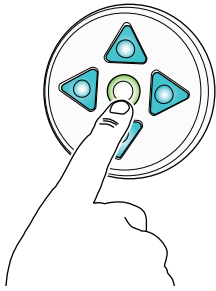

(27) -100.0, -50.0

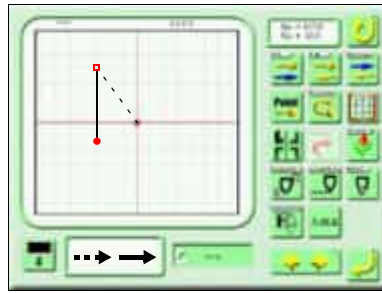

(28)To set

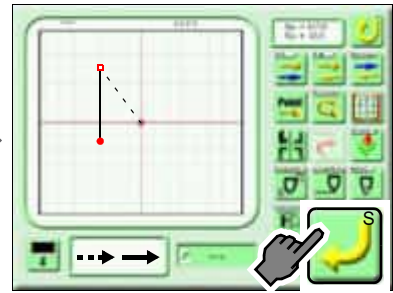

(29)Edit frame

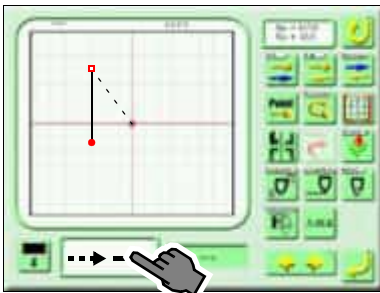

(30)Normal Sewing, Spline

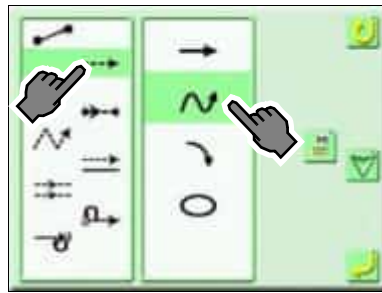

(31)Icon T

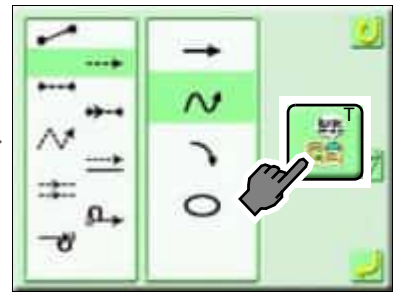

(32)NORMAL

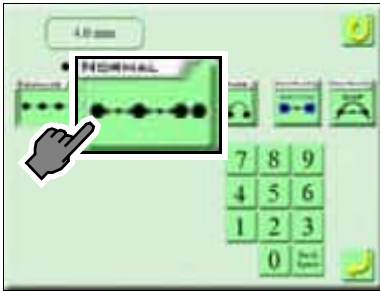

(33)5.0 (mm)

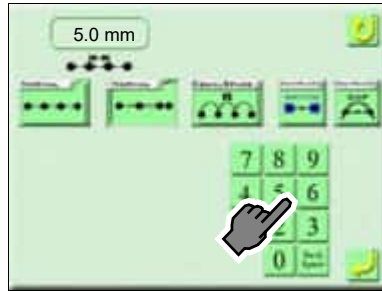

(34)To set

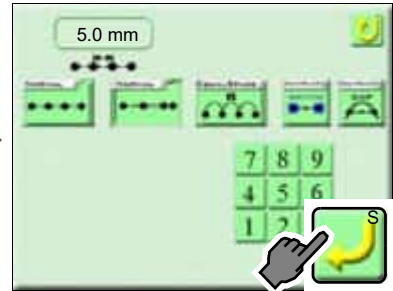

(35)Needle bar selection icon

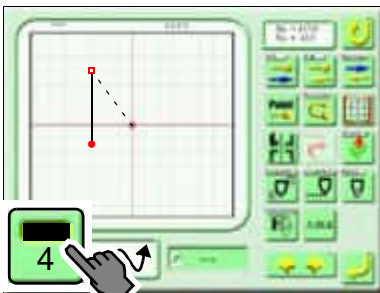

(36)Needle bar No. 7

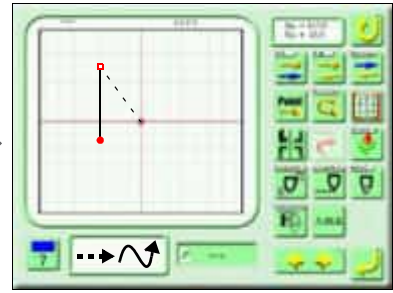
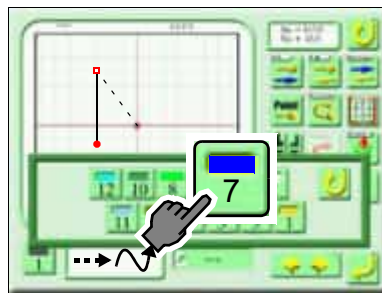

(37)Frame Travel

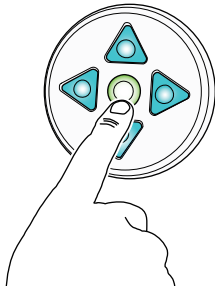

(38) -92.0, -100.0

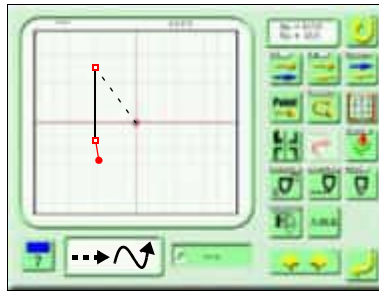

(39)Point

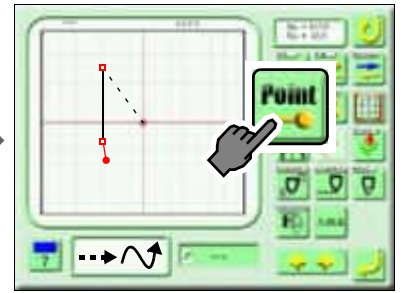

(40)Frame Travel

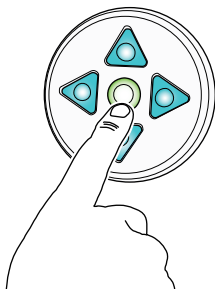

(41) -56.0, -138.0

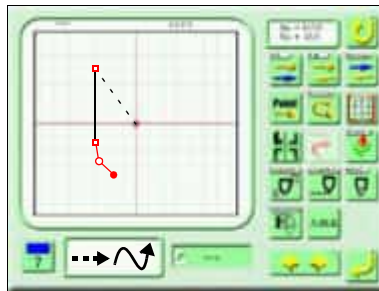

(42)Point

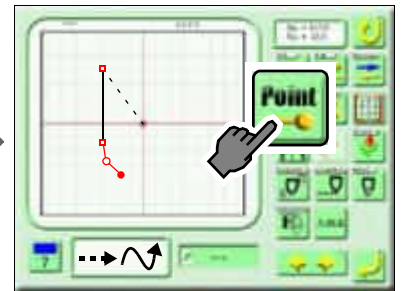

(43)Frame Travel

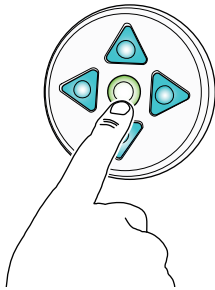

(44)0.0, -150.0

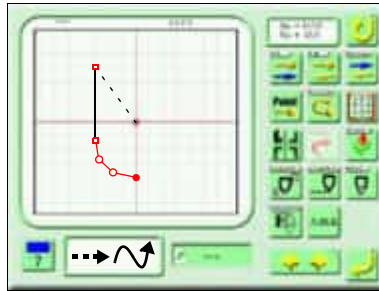

(45)Point

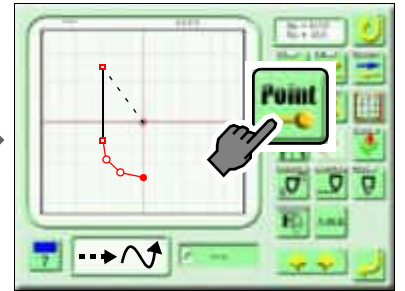

(46)Frame Travel

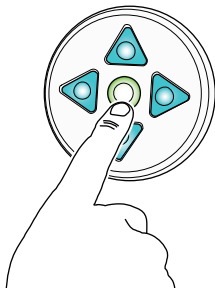

(47) +56.0, -138.0

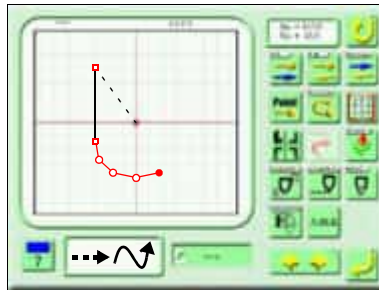

(48)Point

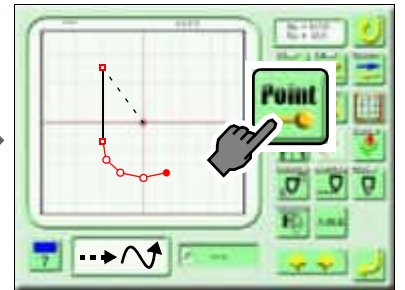

(49)Frame Travel

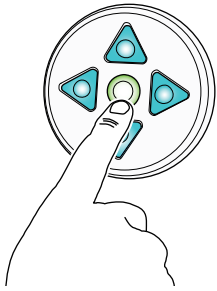

(50) +92.0, -100.0

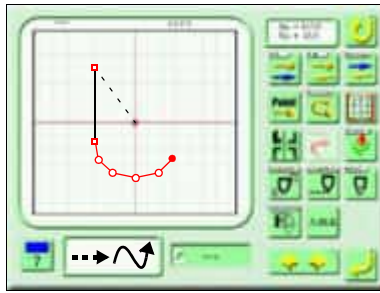

(51)Point

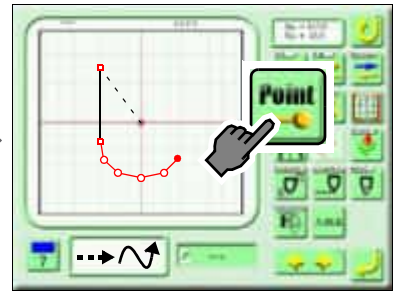

(52)Frame Travel

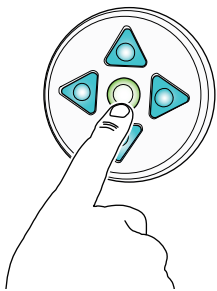

(53) +100.0, -50.0

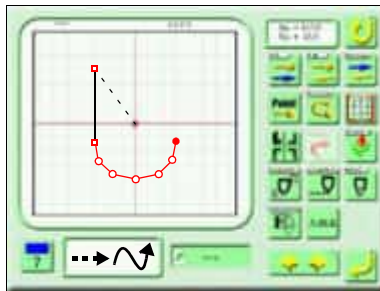

(54)To set

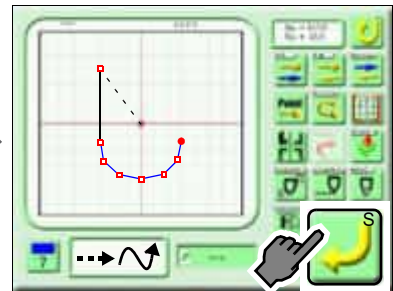

(55)Icon A

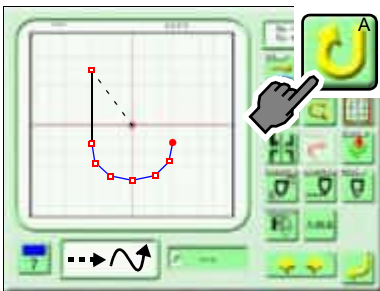

(56) Yes

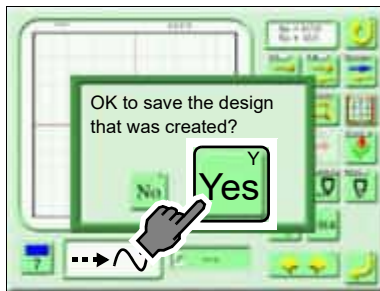

(57)No.

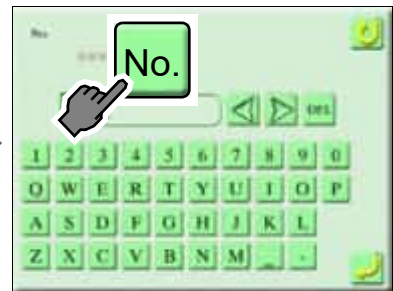

(58)To set

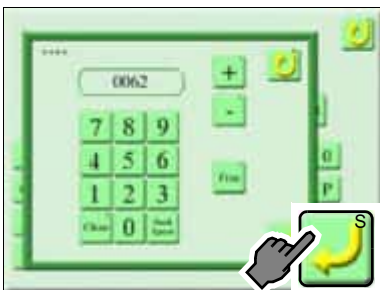

(59)To input design name



(60)To set (Completed)

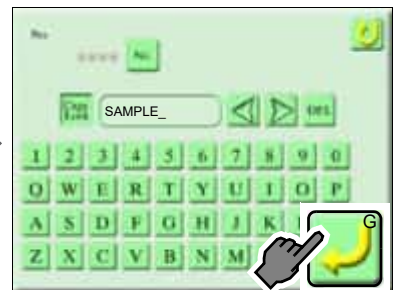

[An example of operation]

Create the following sewing design.

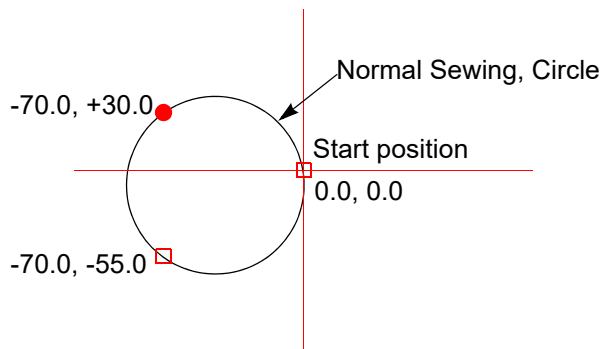

In the following case, a circle cannot be created.

1. When the point is set on a straight line.
2. When the configuration point is not consisted of three points.
3. When a huge circle appears. (Large size of arc which has 10,000 stitches or more in one creation)

(1) Design creation

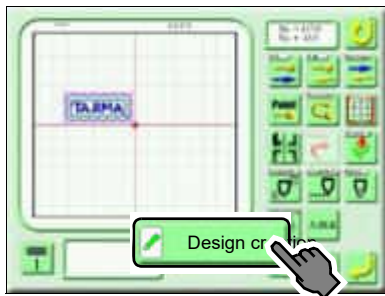

(2) To set Machine Format



Firstly, touch the number, then change the value.

To set Machine Format (→p.174)

(3) To set



(4) Edit frame

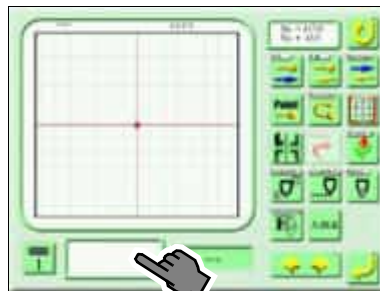

(5) Normal Sewing, Circle

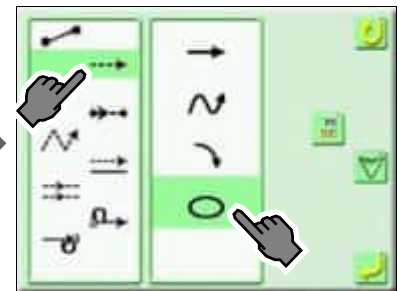

(6) Icon T

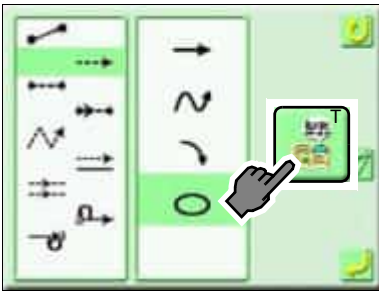

(7) NORMAL

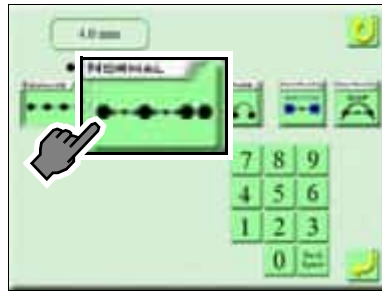

(8) 5.0 (mm)

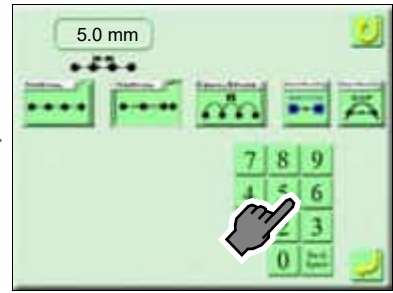

(9) To set

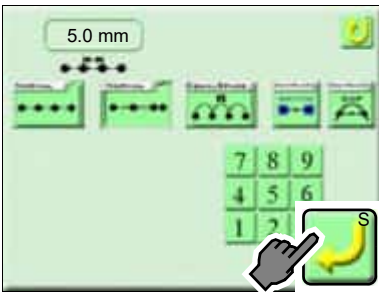

(10) Frame Travel

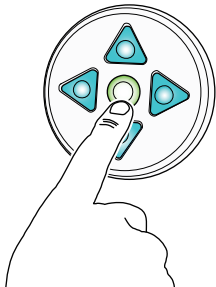

(11) -70.0 -55.0

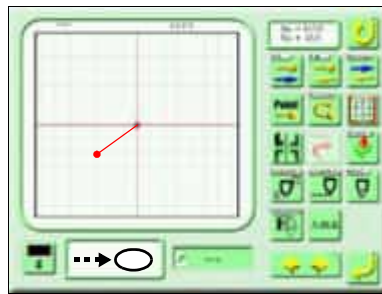

(12) Point

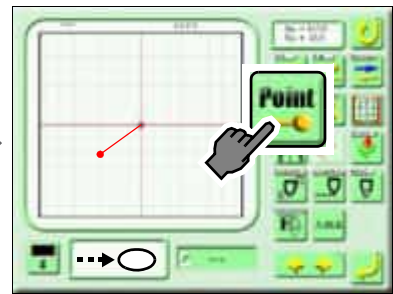

(13) Frame Travel

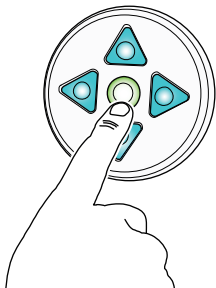

(14) -70.0 +30.0

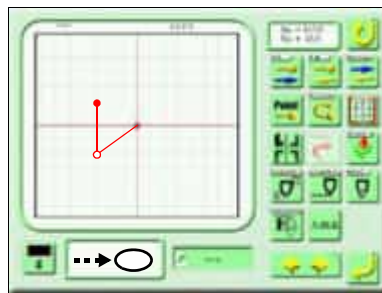

(15) To set (Completed)

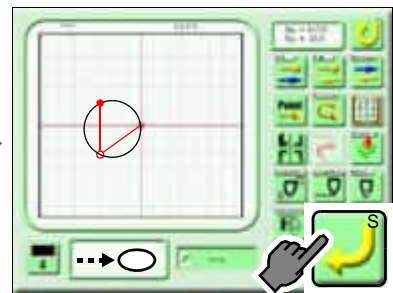

5-8. To perform test sewing of sewing design

This function can be used only for sewing design.

! CAUTION

! Before the start of the operation, pay enough attention to the surrounding safety.
Moving the needle bar and/or the frame could injure you.

At test sewing mode, the parameter setting is disregarded, and sewing will be performed with the setting of "Auto Color Change" and "Auto Start".

[An example of operation]

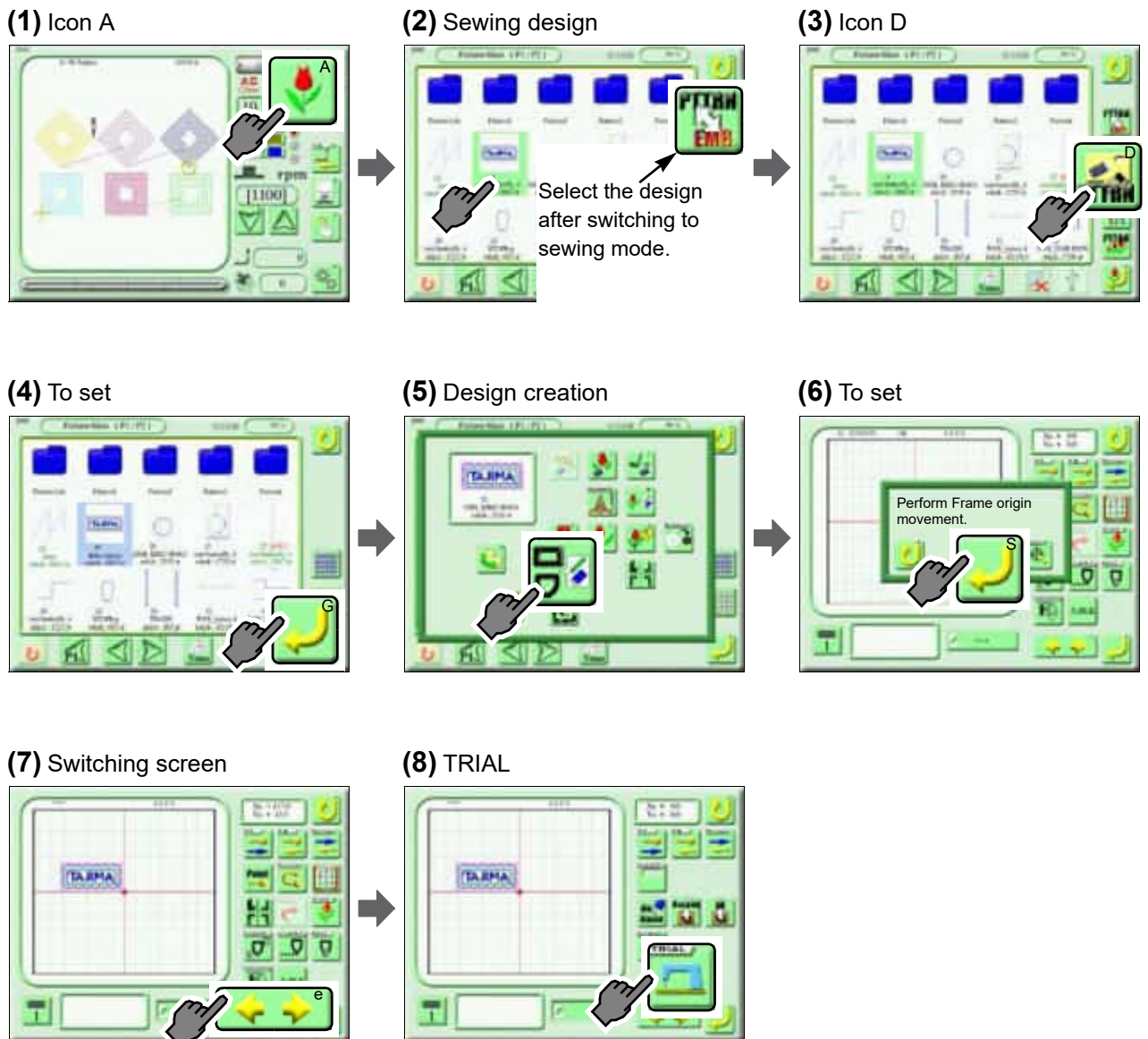

(9) Yes

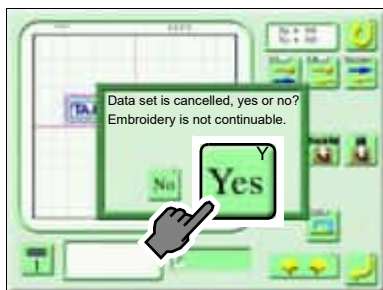

When the design of the set data exists, the message in the left figure will be displayed.

(10) Changing r.p.m.

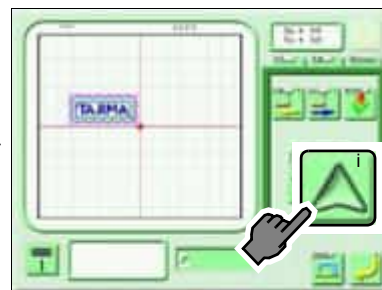

(11) Start the machine.

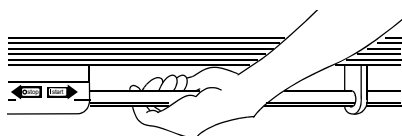

Sewing will be started.

(12) Test sewing is completed.

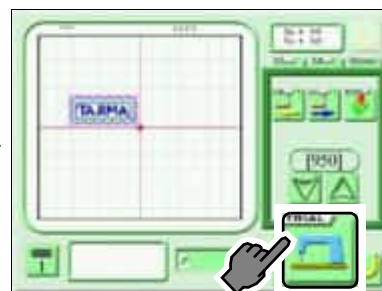

5-9. To change start position of sewing design

This function can be used only for sewing design.

CAUTION

 When performing this operation, do not put your hands etc. on the machine table. Moving the frame could injure you.

[An example of operation]

(1) Icon A

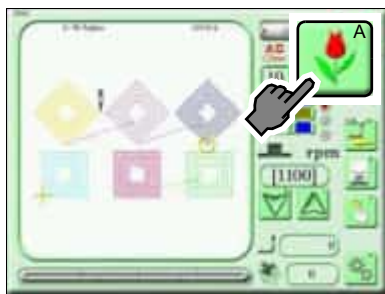

(2) Sewing design

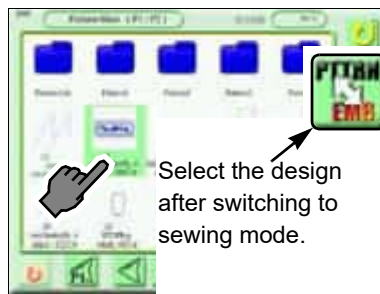

(3) Icon D

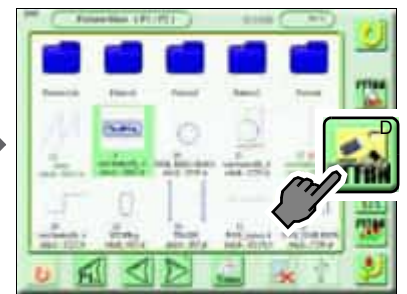

(4) To set

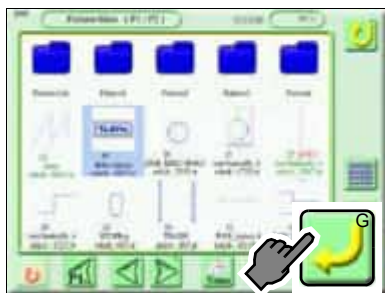

(5) Design creation



(6) To set

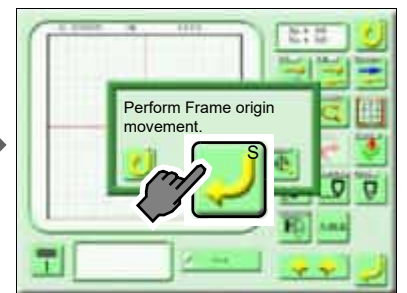

(7) Frame travel to start position

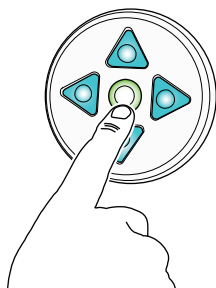

(8) CHANGE

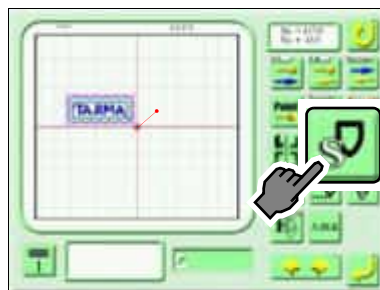

(9) Start position

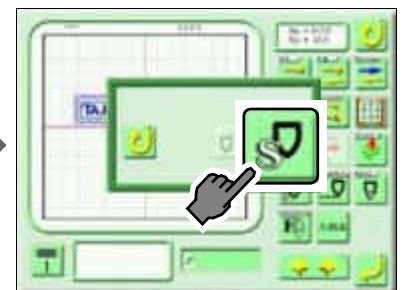

(10)Yes

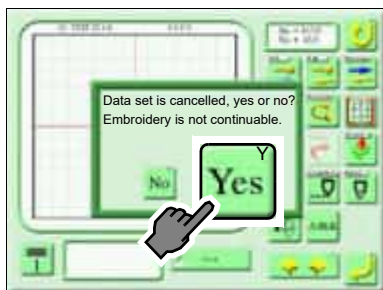

When selecting the design of the set data, the message as shown left will be displayed.

(11)Set (Completed)

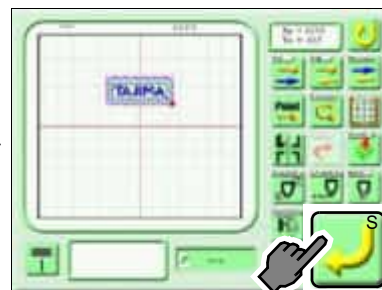

Chapter 8

Convenient functions

1. To move the frame to the position registered 188
2. To change size/direction of sewing design (Data Conversion) 194
3. To repeat sewing design (Repeat)..... 197
4. To change size/direction of embroidery design (Data Conversion) .202
5. To repeat embroidery design (Repeat)206
6. Advanced setting of the needle bar step 211
7. Needle bar color218

1. To move the frame to the position registered

1-1. To move frame automatically at start and end of sewing (Automatic offset)

The frame will move automatically between offset position and start position so that replacement of the frame and the fabric to be stretched can be performed easily. Regarding this function, refer to the detail page. (→p.52)

The frame can move through the middle positions (OF1, OF2) up to two spots. Setting contents here will be included in the design. So, when you sew this design next time, setting again will be unnecessary.

CAUTION

 When performing this operation, do not put your hands, etc. on the table. Moving the frame could injure you.

[How to operate]

Automatic offset will be set and the frame will be moved through 2 spots (OF1, OF2). The below example is an illustration that indicates the frame movement by arrows.

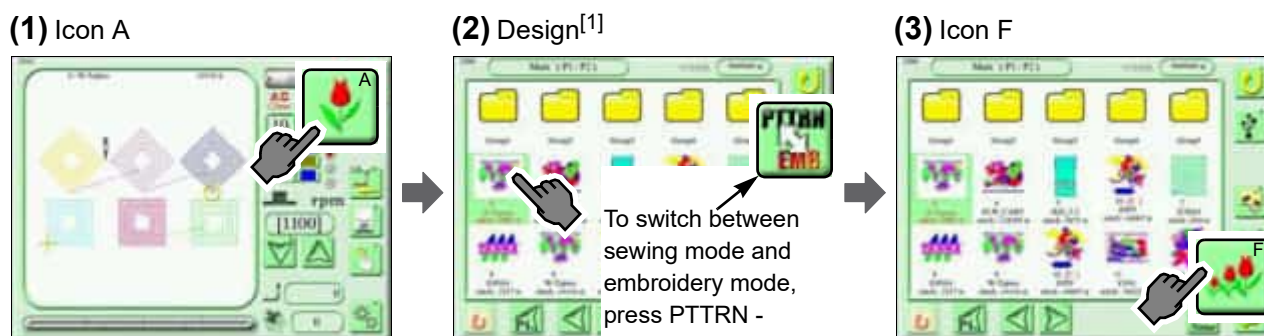
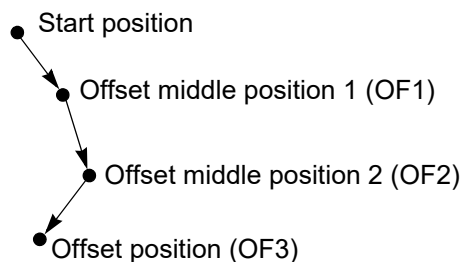

[1]An example of selecting embroidery design

(4) OF

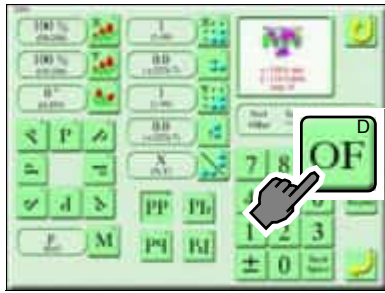

(5) Offset setting screen



Move the frame by the next operation.

It is not possible to change the start position in sewing mode.

(6) Start position

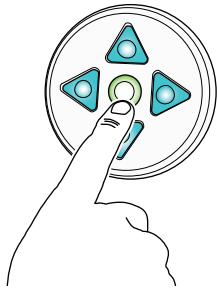

Move the frame to the start position by pressing the frame travel key.

- Start position

(7) Icon S^[1]

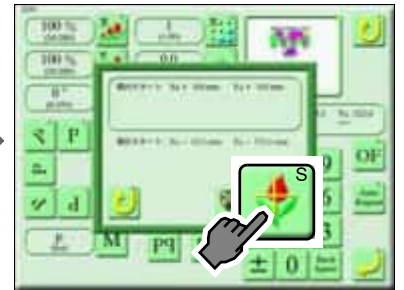

[1]Icon S will not be displayed in sewing mode.

(8) Offset middle position 1

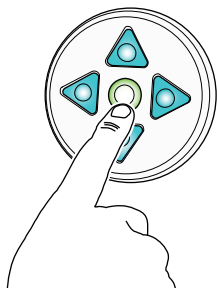

Move the frame to the offset middle position 1 by pressing the frame travel key.

- Start position
- Offset middle position 1

(9) OF1



(10) Offset middle position 2

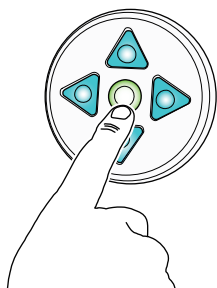

Move the frame to the offset middle position 2 by pressing the frame travel key.

- Start position
- Offset middle position 1
- Offset middle position 2

(11) OF2



(12) Offset position

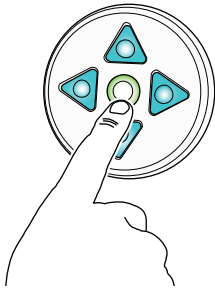

Move the frame to the offset position by pressing the frame travel key.

- Start position
- Offset middle position 1
- Offset middle position 2
- Offset position

(13) OF3

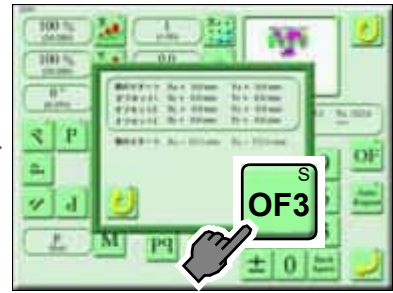

(14) To set (Completed)



1-2. To delete frame position registered (Automatic offset deletion)

CAUTION

When performing this operation, do not put your hands, etc. on the table. Moving the frame could injure you.

[How to operate]

(1) Icon A



(2) Design^[1]

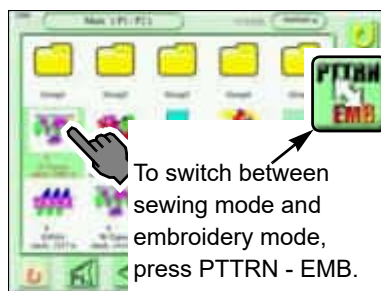

(3) Icon F



[1]An example of selecting embroidery design

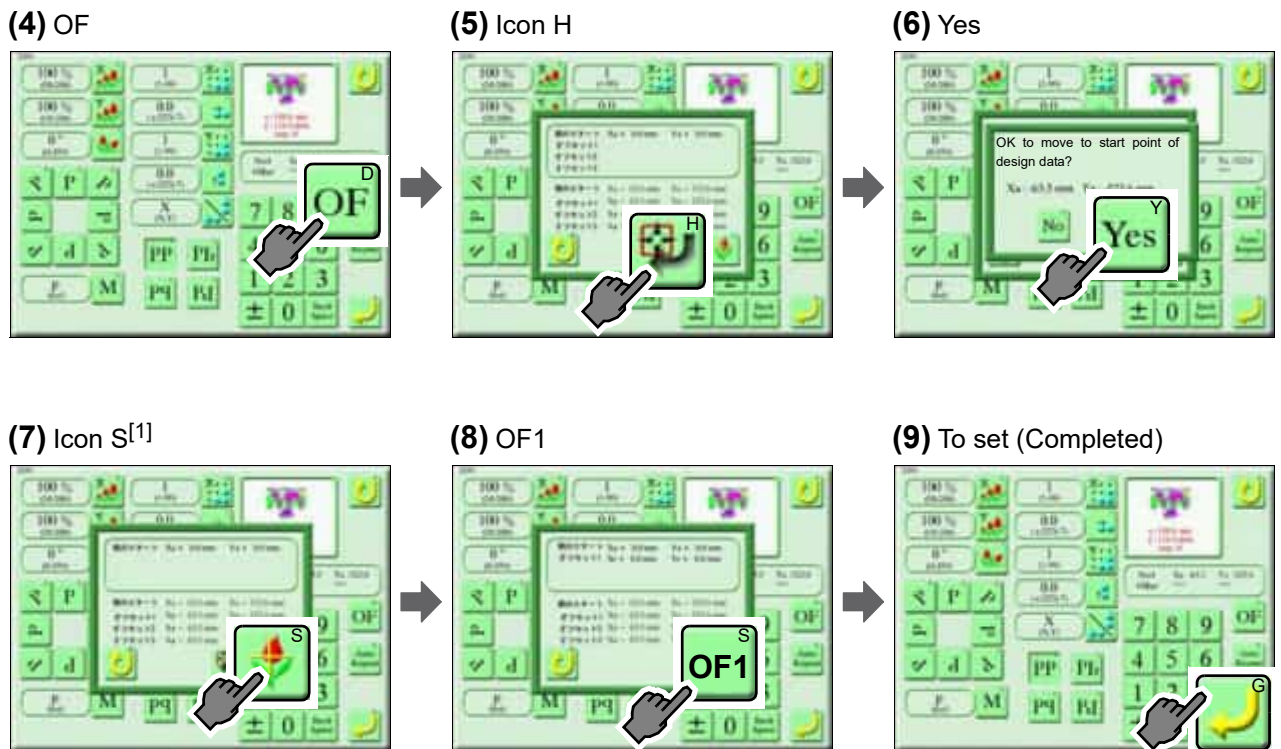

[1]Icon S will not be displayed in sewing mode.

1-3. To move frame at position you desire during sewing (Automatic free setting offset)

Non data "Automatic free-setting offset" code will be inserted in the design data. Thus, the machine will stop by stitch you desire and the frame will move to the front (offset position) automatically during sewing. Therefore, this function is suitable for works of applique and placement sewing etc. To make this function available, the setting of "Automatic Offset" is necessary. (→p.188)

For this function, refer to the detail page. (→p.53)

To use this function, it is necessary to set the functional limit level to "SEL" by inputting a password. (→p.232, p.229)

[How to operate]

"Automatic free-setting offset" code will be inserted at 480th stitch.

(1) Set the functional limit level to "SEL".

(2) Decide the frame position by "Automatic offset". (→p.188)

(3) Icon A

(4) Design

(5) Icon D

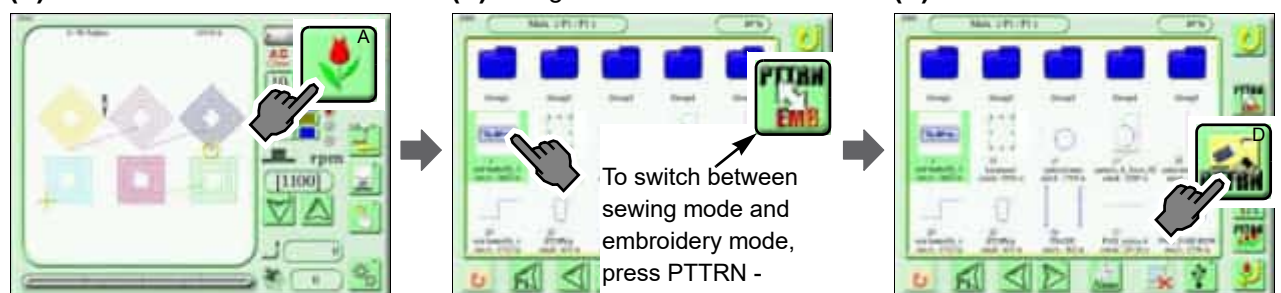

(6) To set

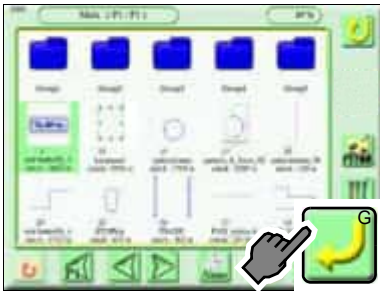

(7) Icon M



(8) Input 480

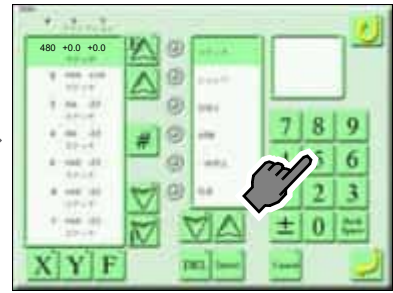

(9) Icon j



(10) Insert

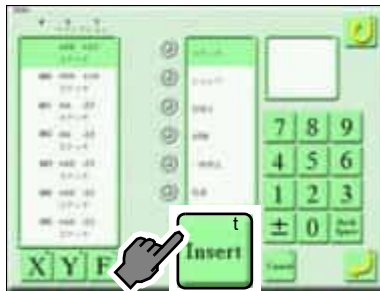

(11) F

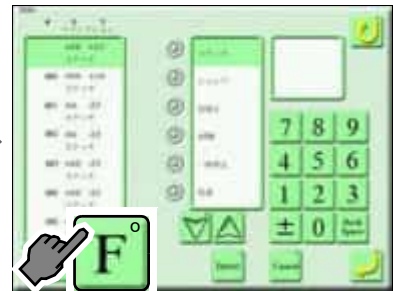

(12) Icon q

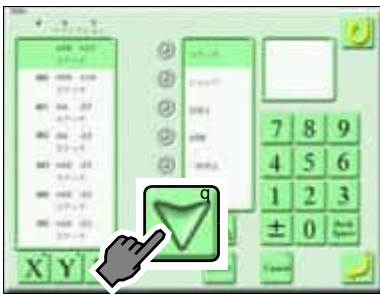

(13) Automatic free-setting offset

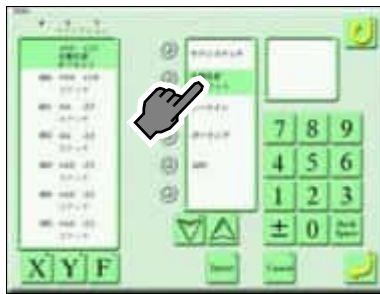

(14) To set (Completed)



1-4. To move frame at color change position during sewing (Auto color change offset)

"Offset" will be inserted to the needle bar step by the operation of selecting the needle bar. Thus, the machine will stop at the color change position you desire and the frame will move to the front (offset position) automatically during sewing. Therefore, this function is suitable for works of applique and the placement sewing, etc. To make this function available, the setting of "Automatic Offset" is necessary. (→p.188)

For this function, refer to the detail page. (→p.54)

[How to operate]

Insert "Offset" after Step 4.

(1) Decide the frame position by "Automatic offset". (→p.188)

(2) Icon A

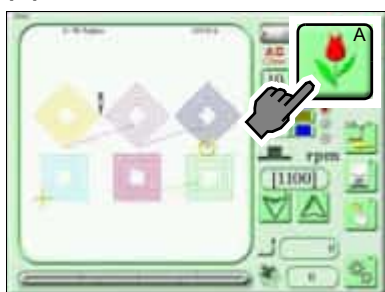

(3) Design

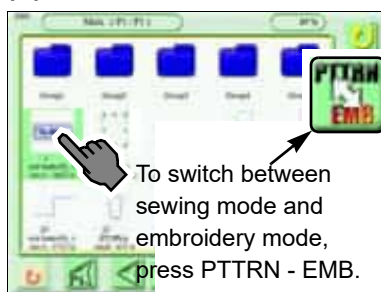

(4) Icon E

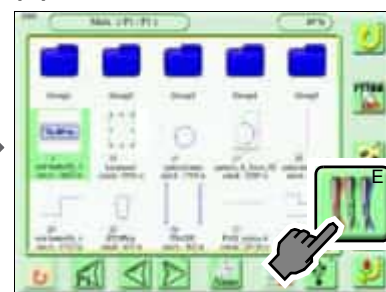

(5) Step 4

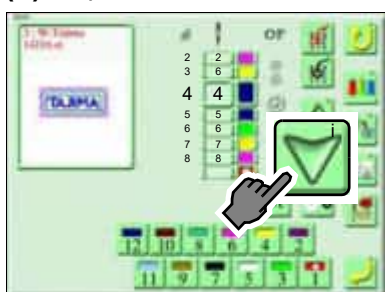

(6) OF

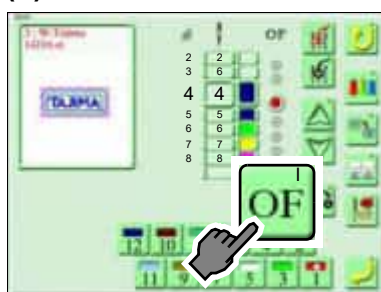

If "OF" is pressed, the offset lamp will be lit in red.



(7) To set (Completed)

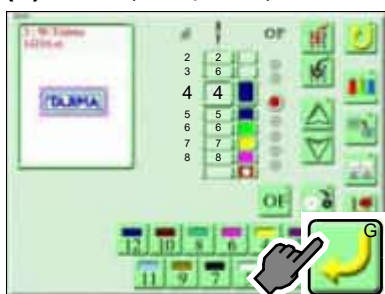

2. To change size/direction of sewing design (Data Conversion)

When the rotation and the reversion are set at the same time, the data will be changed in order from the rotation to the reversion.

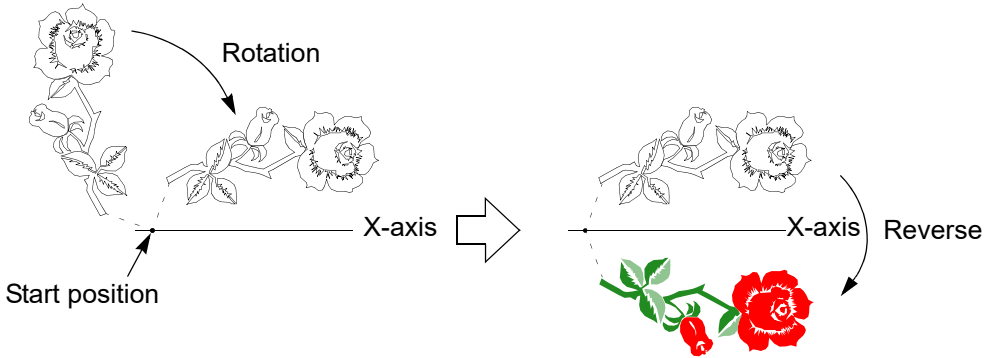

2-1. To scale up/down sewing design

[How to operate]

Enlarge the design to 150% in vertical and horizontal.

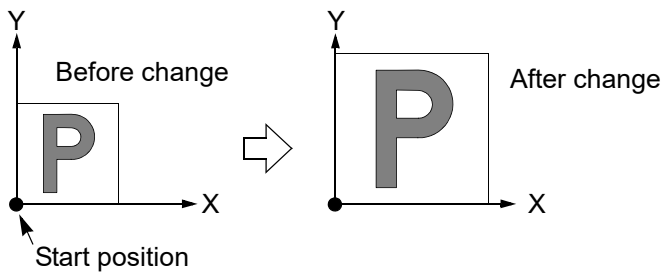

(1) Icon A



(2) Sewing design

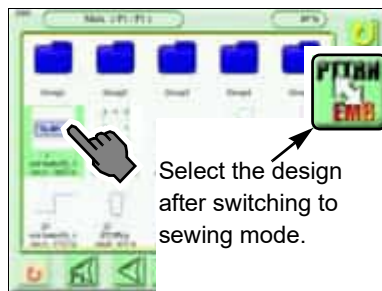

(3) PTTRN

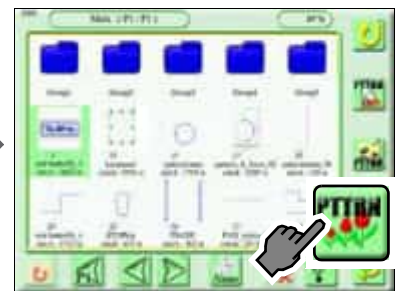

(4) X

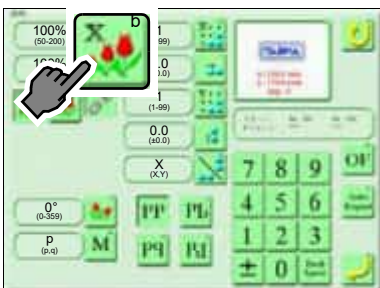

(5) 150 (%)



Same values of X and Y are input.



It is possible to input the value of X or Y individually.

(6) To set (Completed)

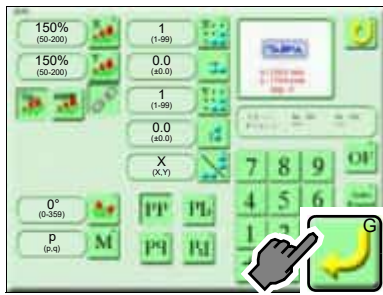

2-2. To rotate sewing design

[How to operate]

Rotate the design by 45°.

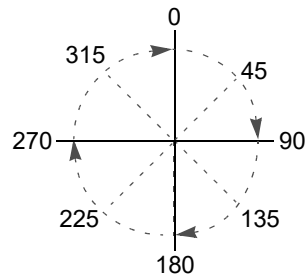
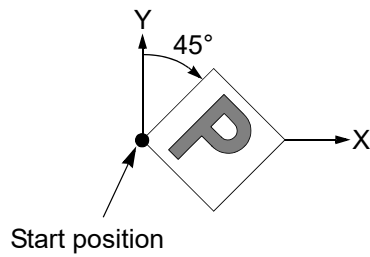

(1) Icon A



(2) Sewing design

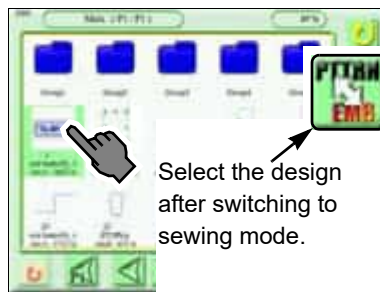

(3) PTTN

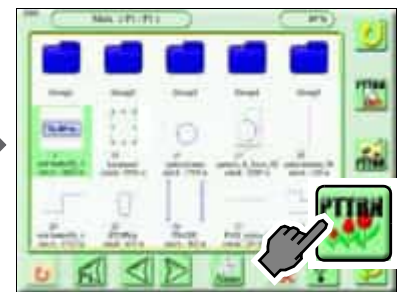

(4) Icon f

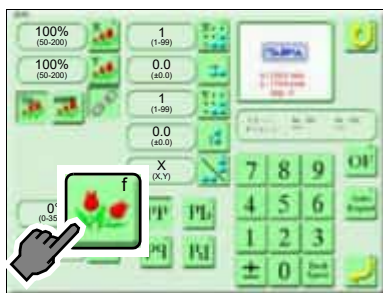

(5) 45 (°)

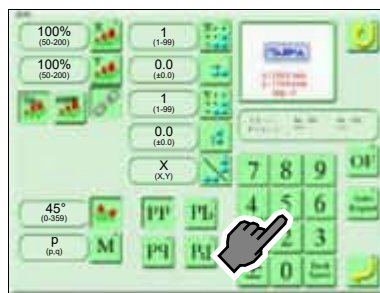

(6) To set

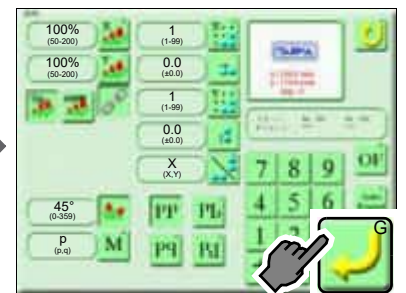

2-3. To reverse sewing design

[How to operate]

Reverse the design.

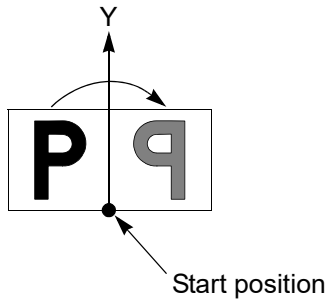

(1) Icon A

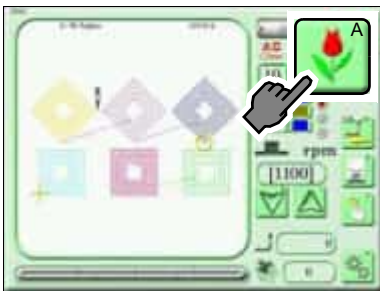

(2) Sewing design

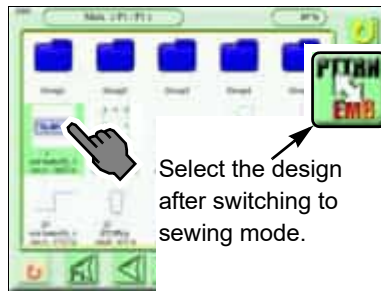

(3) PTTRN

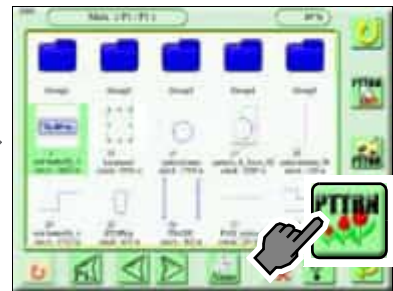

(4) M

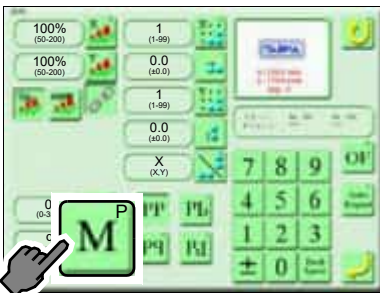

p Reverse is not performed.

q Reverse is performed.

(5) To set (Completed)

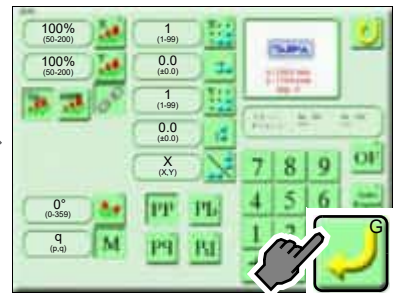

3. To repeat sewing design (Repeat)

When repeating the design changed size and direction, this function will repeat the design of shape enlarged/reduced, rotated and reversed.

3-1. To repeat by specifying vertical or horizontal and number of times

[How to operate]

Three times in horizontal, 50 mm of design interval,
 Two times in vertical, -60 mm of design interval,
 Repeat direction: In horizontal

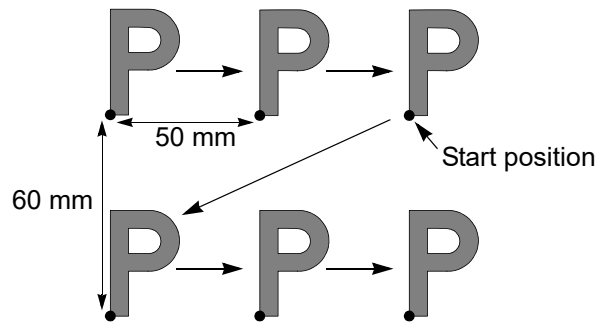

(1) Icon A



(2) Sewing design

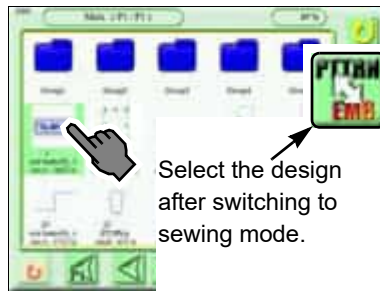

(3) PTTRN

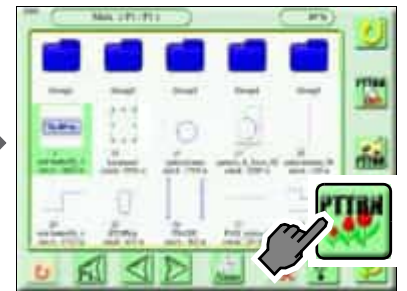

(4) X

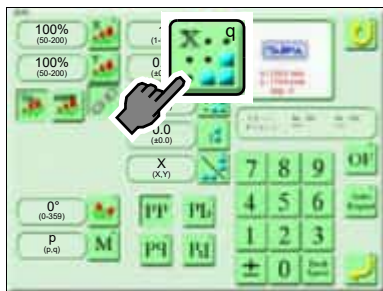

(5) Three (times)

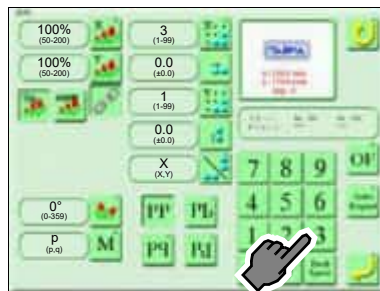

(6) Icon r

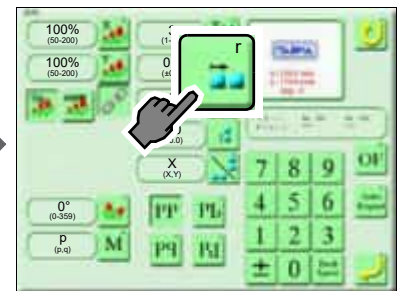

(7) +50.0 (mm)

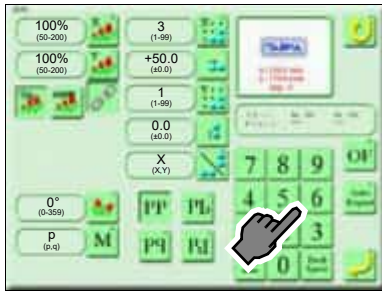

When repeating design to right direction

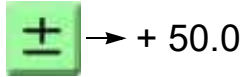

When repeating design to left direction

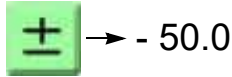

(8) Y

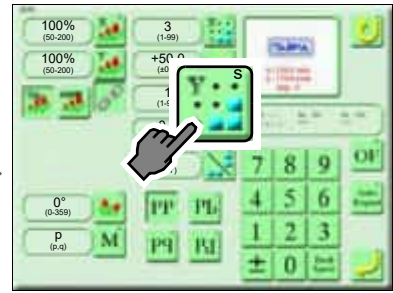

(9) Two (times)



(10) Icon t

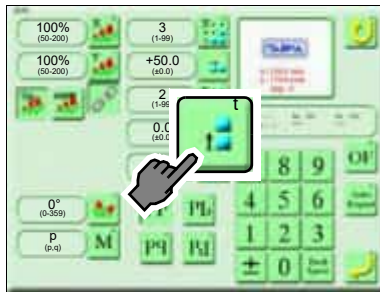

(11)-60.0 (mm)



When repeating design to upper direction

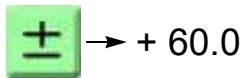

When repeating design to lower direction

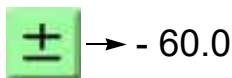

(12) Icon u

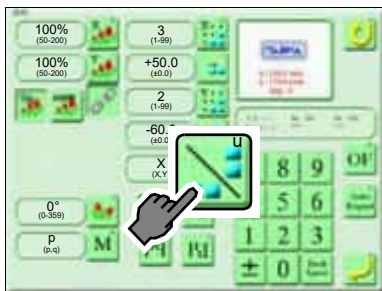

Priority to X (Horizontal)



Priority to Y (Vertical)



(13) To set (Completed)



3-2. To arrange automatically

This function will automatically calculate the number of designs that can be arranged within the frame.

[How to operate]

Arrange the distance (horizontal) of the design to 50 mm, the distance (vertical) of the design to 60 mm and at the center.

(1) Icon A

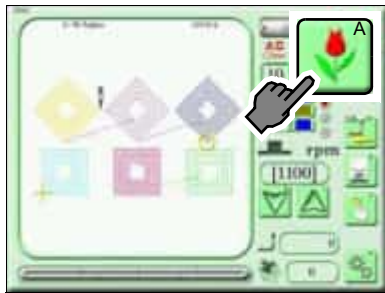

(2) Sewing design

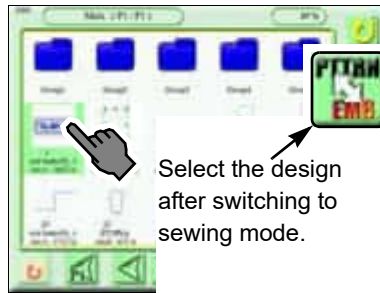

(3) PTTRN

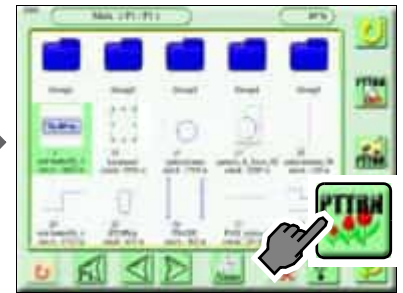

(4) Auto Repeat



(5) 50.0 (mm)



(6) Icon i

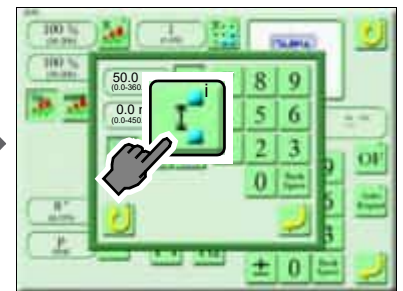

(7) 60.0 (mm)



(8) Icon j

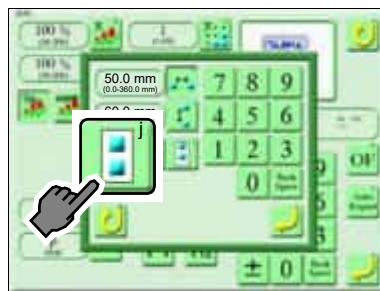

Arrange at the center.

Arrange from the front.

Arrange from rear.

(9) To set (Completed)

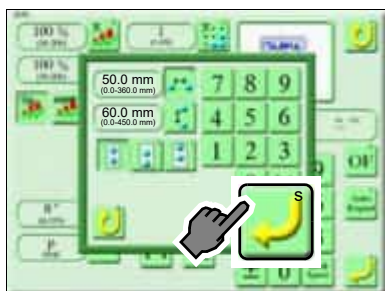

Number of repeating times in horizontal and vertical, and the start position have just been registered.

3-3. To reverse alternately

The design being set repeat will be sewn at odd Nth (number) time and even Nth time by reversing alternately.

[How to operate]

Reverse based on X-axis.

(1) Icon A

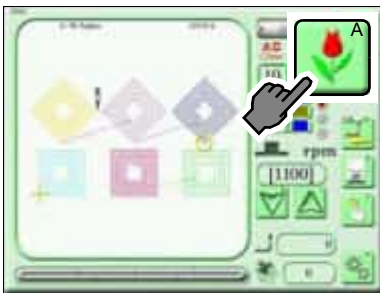

(2) Sewing design

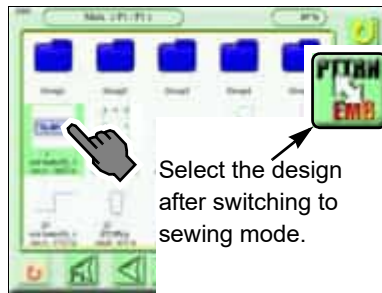

Select the design after switching to sewing mode.

(3) PTTRN

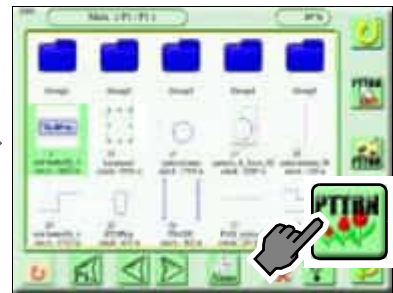

(4) X

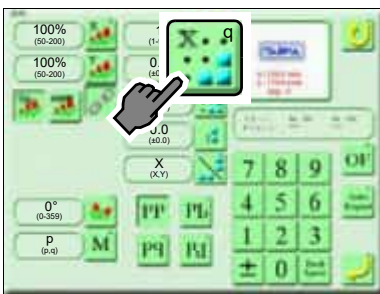

After that, set repeating time in horizontal and vertical, a distance and repeating direction.

Regarding how to operate, refer to the detail page. (→p.197)

(5) Icon x

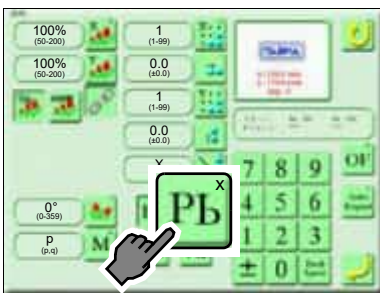

Reverse based on X-axis.

Example: Priority in vertical

Odd-numbered times

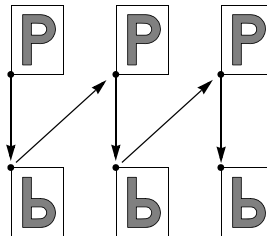

Even-numbered times

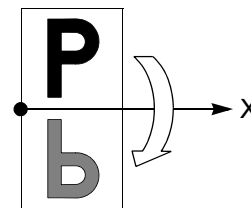



Reverse based on Y-axis.

Example: Priority in vertical

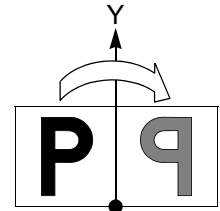
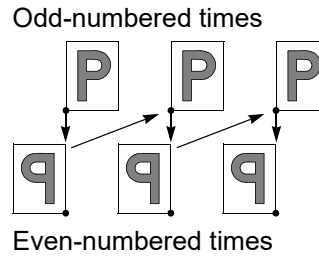

Rotate by 180°.

Example: Priority in vertical

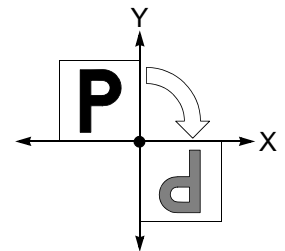
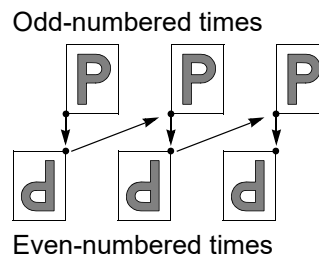

(6) To set (Completed)



4. To change size/direction of embroidery design (Data Conversion)

When the rotation and the reversion are set at the same time, the data will be changed in order from the rotation to the reversion.

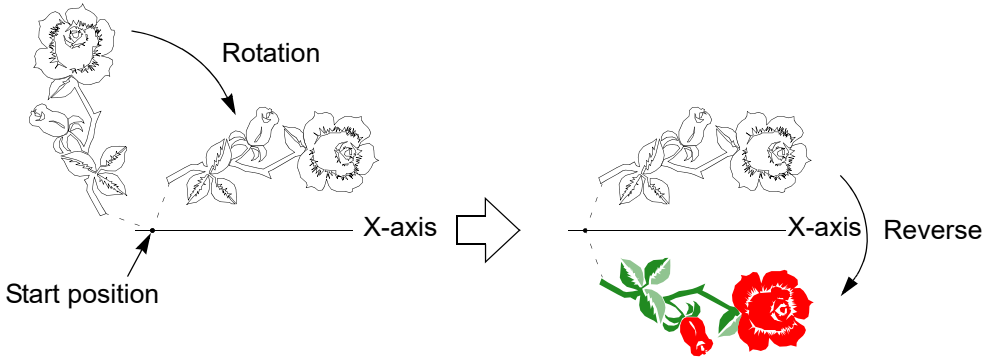

4-1. To scale up/down embroidery design

[How to operate]

Enlarge the design to 150% in vertical and horizontal.

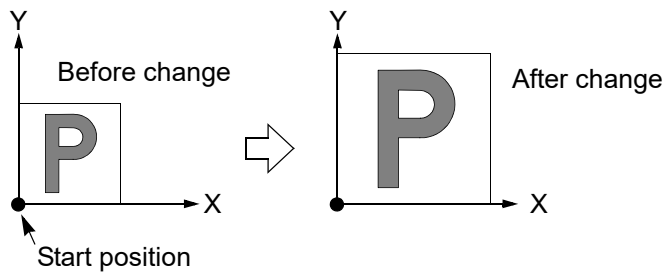

(1) Icon A

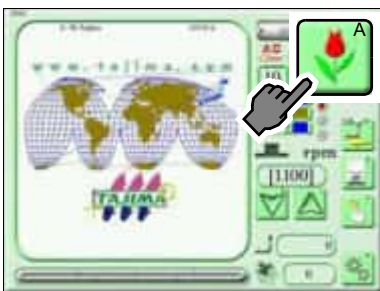

(2) Embroidery design

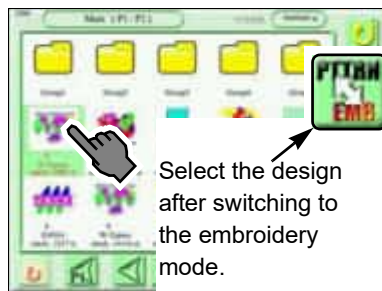

(3) Icon F

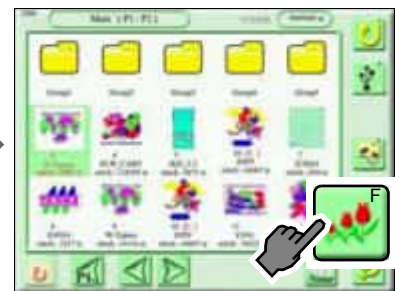

(4) X

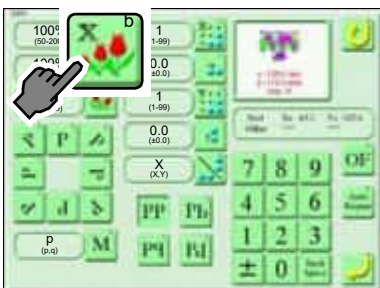

(5) 150 (%)

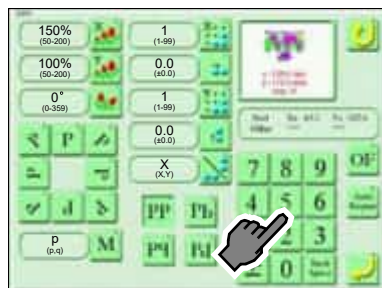

(6) Y

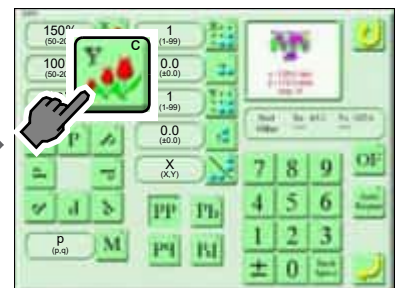

(7) 150 (%)

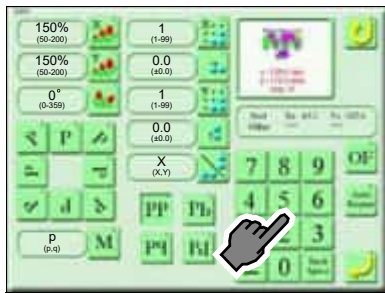

(8) To set (Completed)

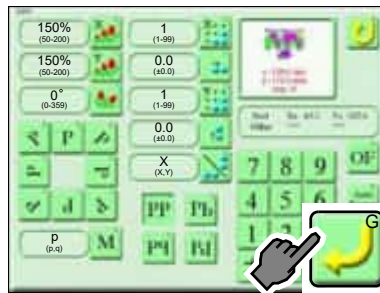

4-2. To rotate embroidery design

[How to operate]

Rotate the design by 45° unit. (45° in this example)

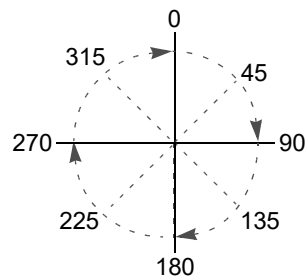
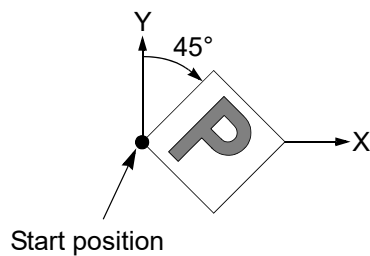

(1) Icon A

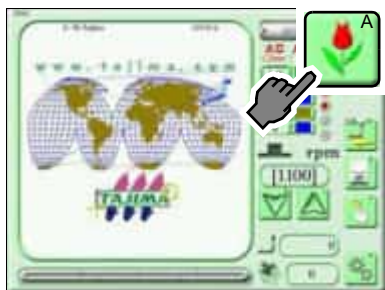

(2) Embroidery design

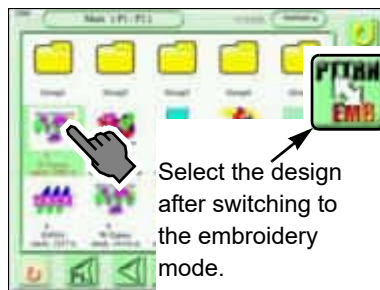

(3) Icon F

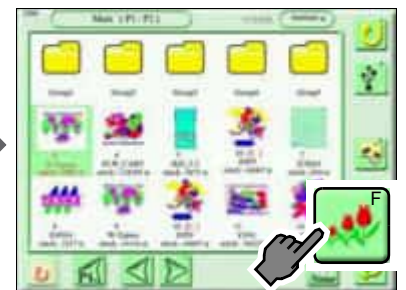

(4) Icon m

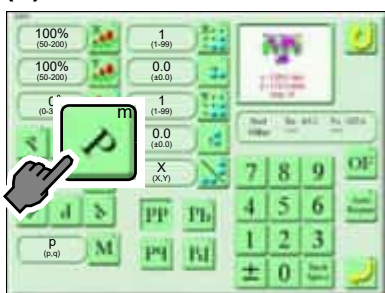

(5) To set (Completed)



[How to operate]

Rotate the design by 1° unit. (5° in this example)

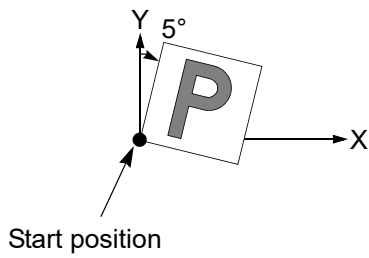

(1) Icon A

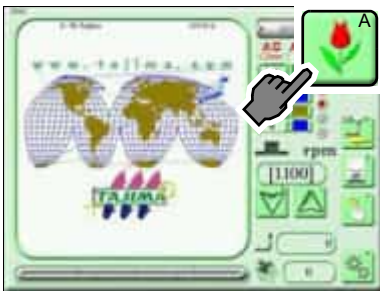

(2) Embroidery design

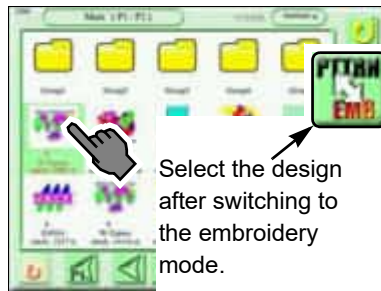

(3) Icon F

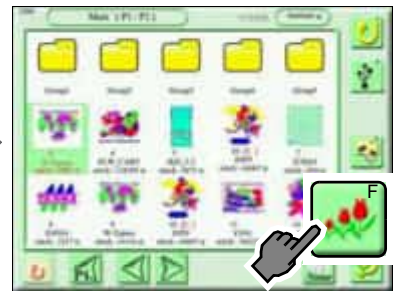

(4) Icon f

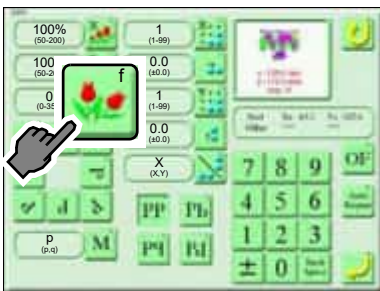

(5) 5 (°)

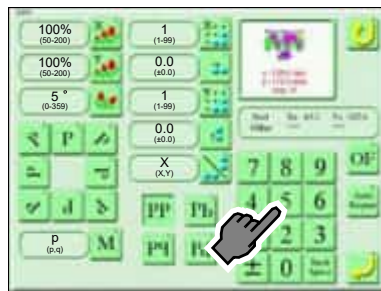

(6) To set (Completed)

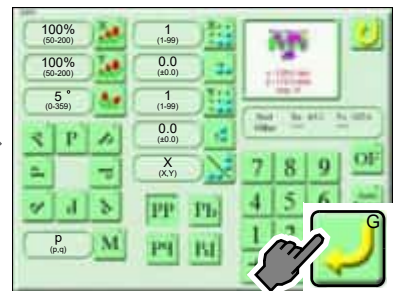

4-3. To reverse embroidery design

[How to operate]

Reverse the design.

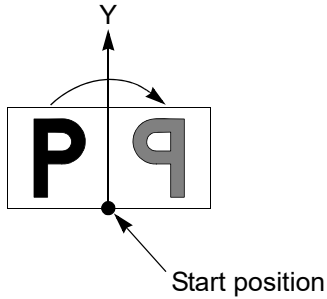

(1) Icon A



(2) Embroidery design

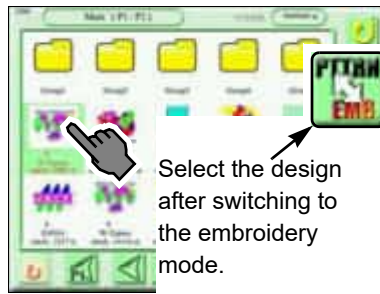

(3) Icon F

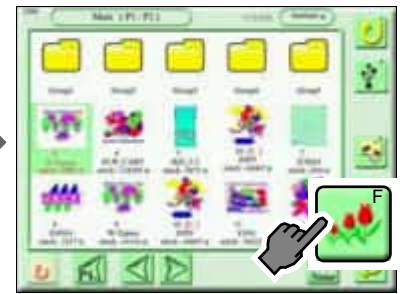

(4) M

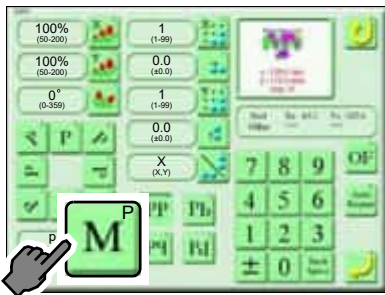

- p Reverse is not performed.
- q Reverse is performed.

(5) To set (Completed)

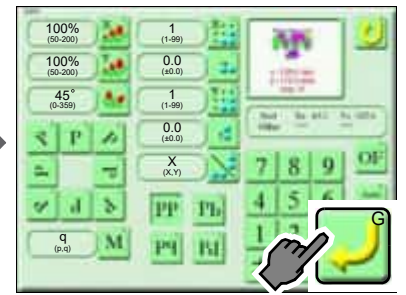

5. To repeat embroidery design (Repeat)

When repeating the design changed size and direction, this function will repeat the design of shape enlarged/ reduced, rotated and reversed.

5-1. To repeat by specifying vertical or horizontal and number of times

[How to operate]

Three times in horizontal, 50 mm of design interval, two times in vertical, 60 mm of design interval, repeat direction: in horizontal

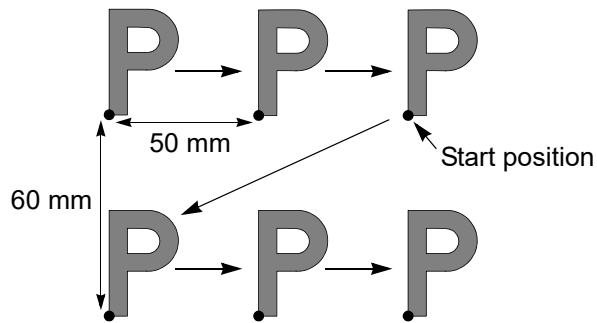

(1) Icon A

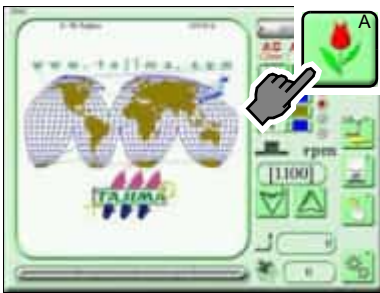

(2) Embroidery design

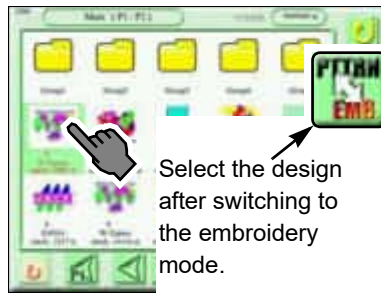

(3) Icon F

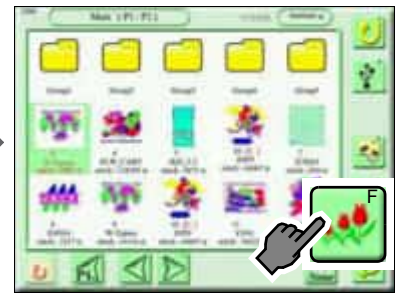

(4) X

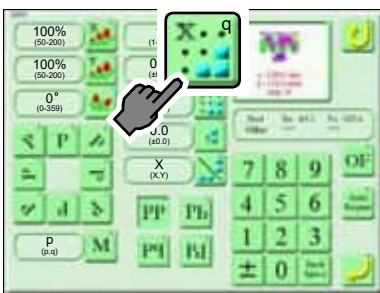

(5) Three (times)

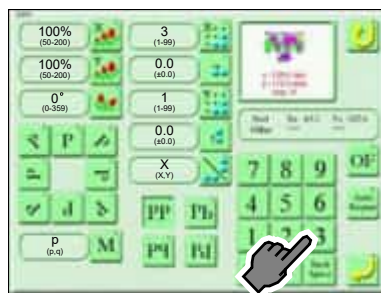

(6) Icon r

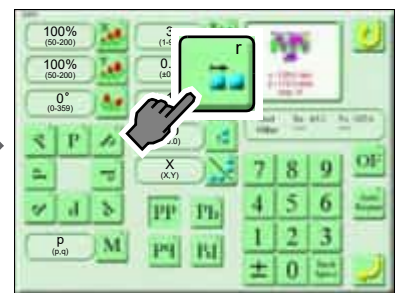

(7) +50.0 (mm)

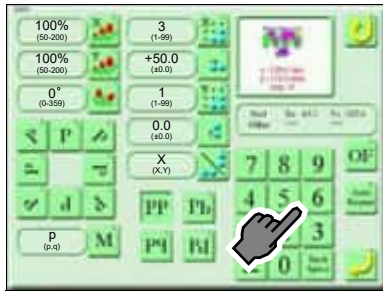

When repeating design to right direction

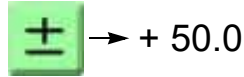

When repeating design to left direction

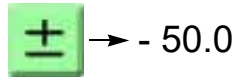

(8) Y

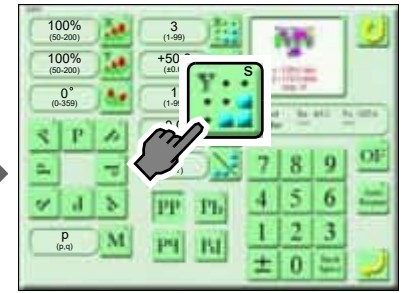

(9) Two (times)



(10) Icon t

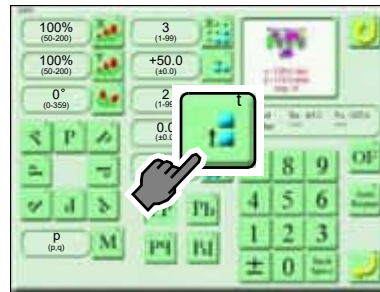

(11) -60.0 (mm)



When repeating design to upper direction

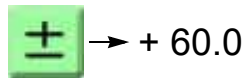

When repeating design to lower direction



(12) Icon u

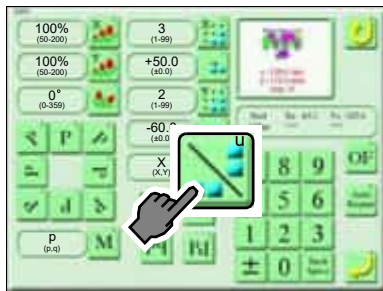

Priority to X (Horizontal)



Priority to Y (Vertical)



(13) To set (Completed)



5-2. To arrange automatically

The machine will automatically calculate the number of designs that can be arranged within the embroidery space, then will perform embroidery.

[How to operate]

Arrange the distance (horizontal) of the design to 50 mm, the distance (vertical) of the design to 60 mm and at the center.

(1) Icon A

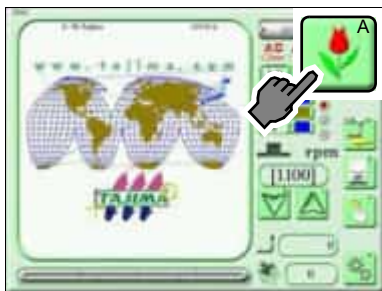

(2) Embroidery design

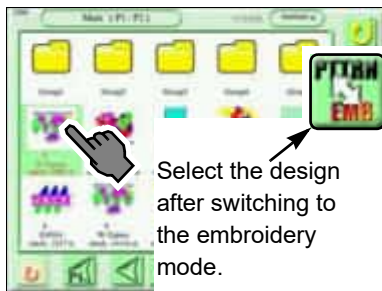

(3) Icon F

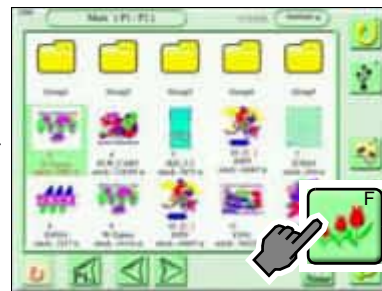

(4) Auto Repeat

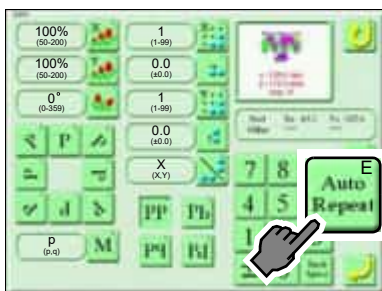

(5) 50.0 (mm)



(6) Icon i



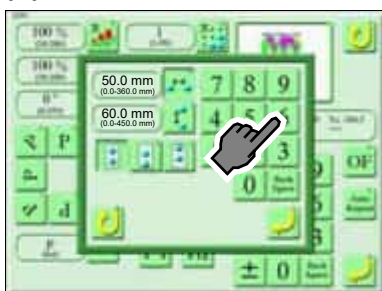

(7) 60.0 (mm)

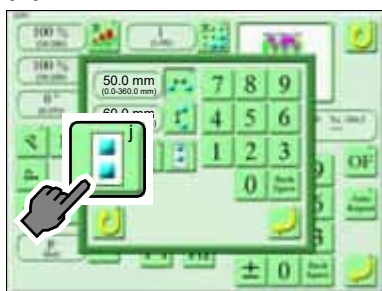

(8) Icon j



-  Arrange at the center.
-  Arrange from the front.
-  Arrange from rear.

(9) To set (Completed)

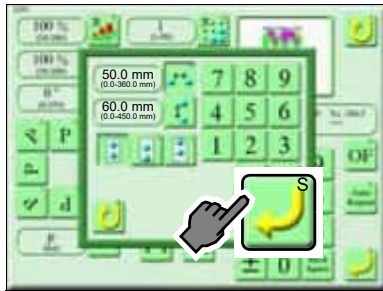

Number of repeating times in horizontal and vertical, and the start position have just been registered.

5-3. To reverse alternately

The design being set repeat will be embroidered at odd Nth (number) time and even Nth time by reversing alternately.

[How to operate]

Reverse based on X-axis.

(1) Icon A

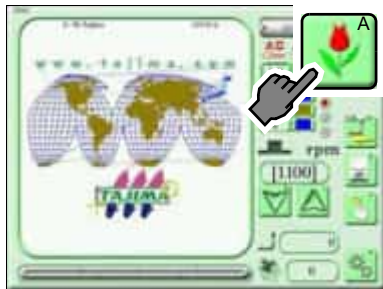

(2) Embroidery design

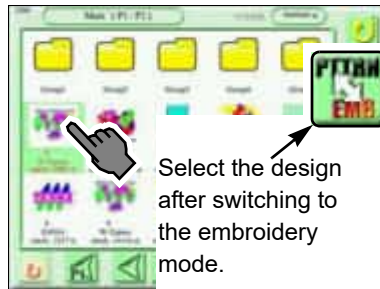

Select the design after switching to the embroidery mode.

(3) Icon F

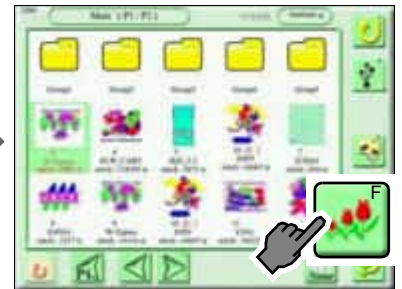

(4) X

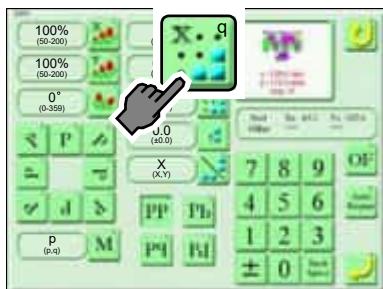

After that, set repeating time in horizontal and vertical, a distance and repeating direction.

Regarding how to operate, refer to the detail page. (→p.197)

(5) Icon x

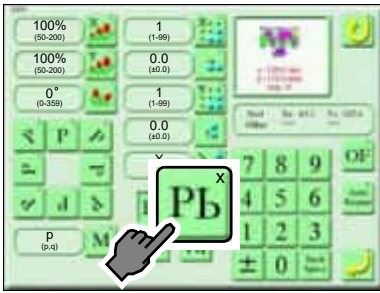

Reverse based on X-axis.

Example: Priority in vertical

Odd-numbered times

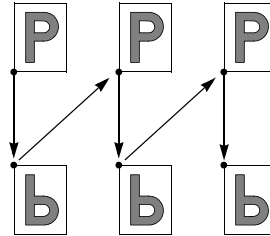

Even-numbered times

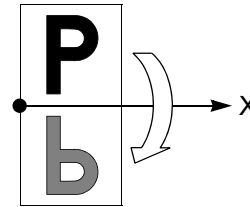

Reverse based on Y-axis.

Example: Priority in vertical

Odd-numbered times

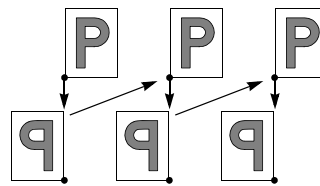

Even-numbered times

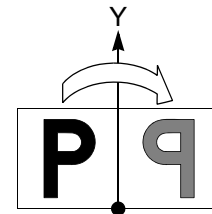

Rotate by 180°.

Example: Priority in vertical

Odd-numbered times

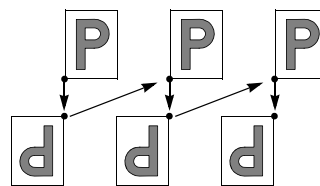

Even-numbered times

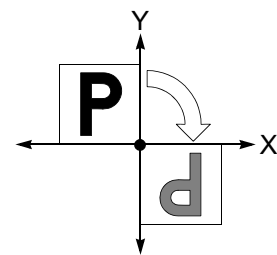

(6) To set (Completed)

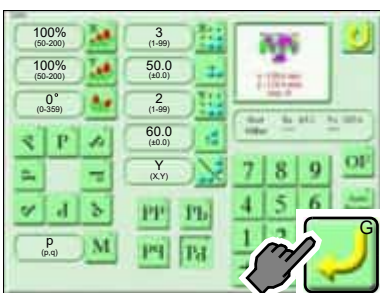

6. Advanced setting of the needle bar step

6-1. To delete the needle bar selection setting

[How to operate]

Delete the setting of needle bar selection at Step 4 to move up to the setting of after.

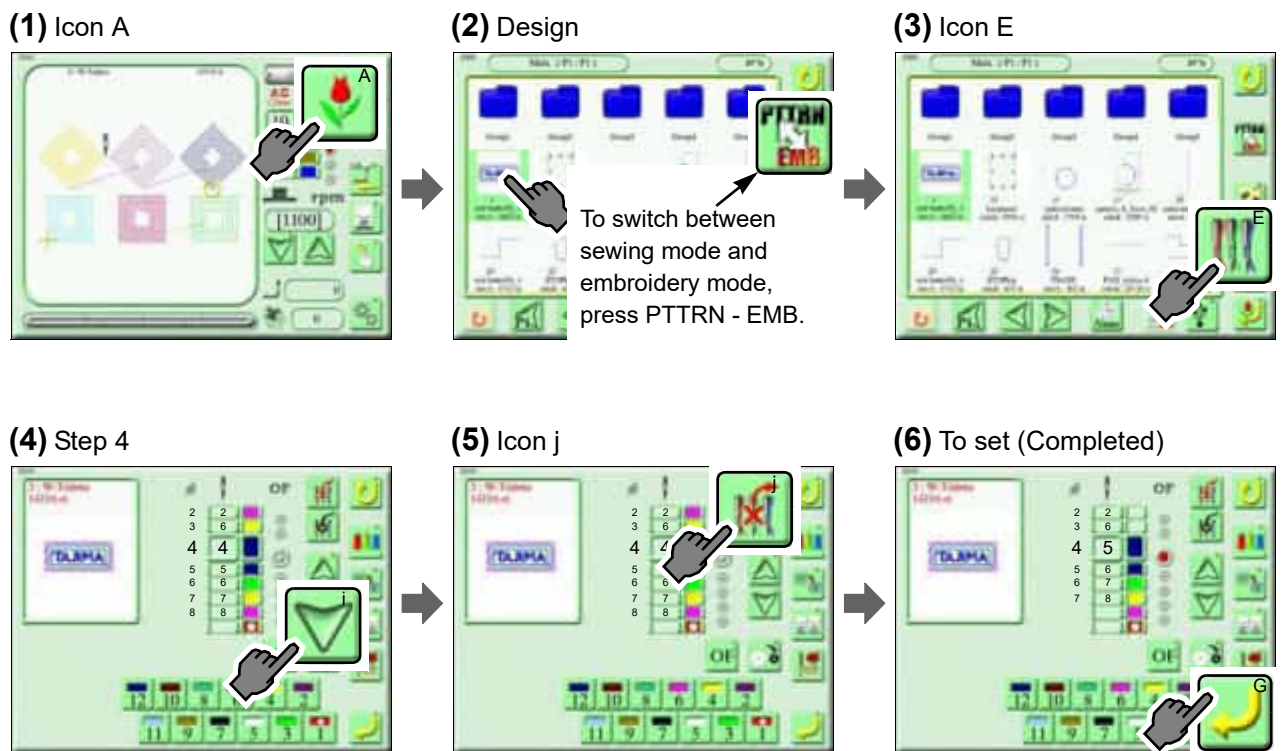

6-2. To insert the new setting in the needle bar selection setting

[How to operate]

Insert step after Step 4 to move down to the setting of after.

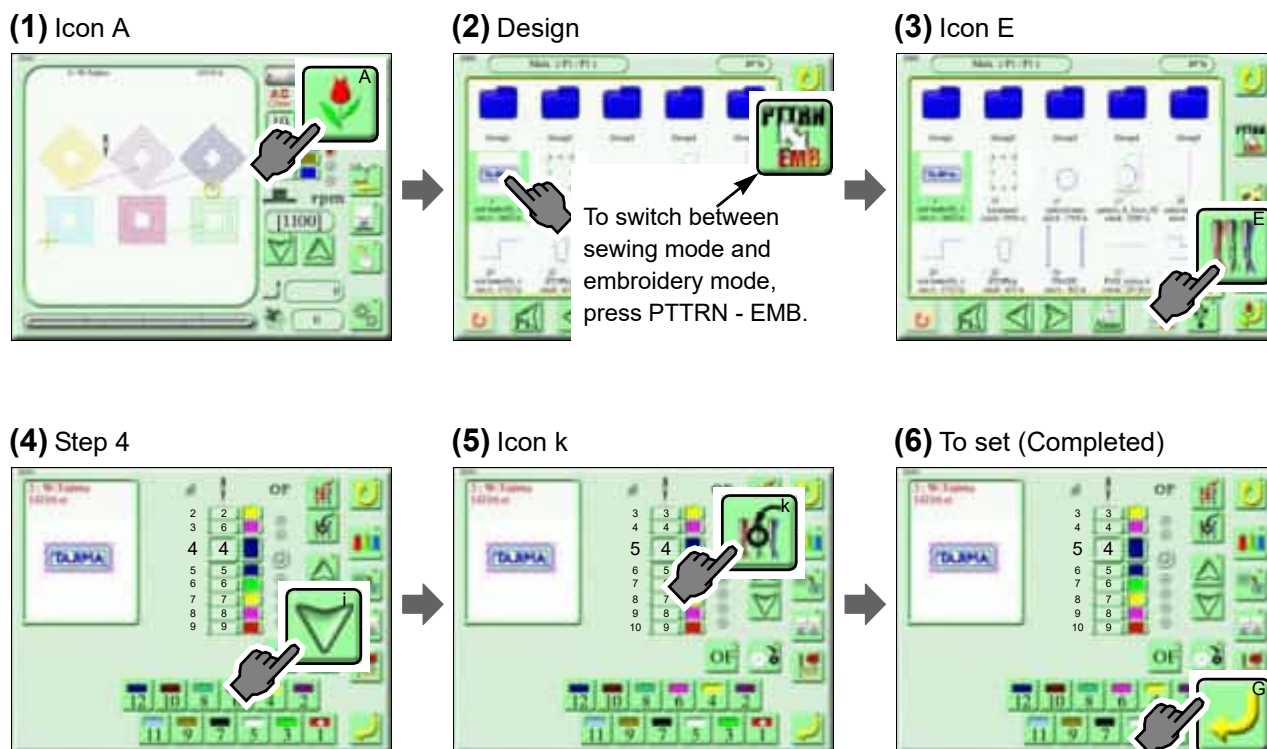

6-3. To sew only desired step by changing setting (Setting in unit of step)

It is possible to give individual setting to desired steps to change the sewing condition by this machine.

For item overlapping with the setting value of the machine parameter, the value here will take priority.

[Detailed explanation]

Screen 2010

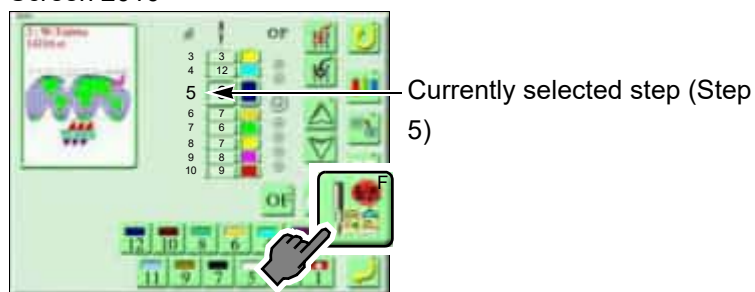

Next page

After setting, press icon.

Enlarged

Page P1

Page P2

Page P3

Next page

- Current step (Step 5) / Total step number of design
- Number of needle at Step 5
- Number of jump code included in Step 5
- Number of sequin output 1 included in Step 5
- Number of sequin output 2 included in Step 5
- Step 4
- Needle bar No. and needle bar color of Step 4
- Step 6
- Needle bar No. and needle bar color at Step 6
- Needle bar selection icon
It is possible to change needle bar No. at Step 5.
- Needle bar No. at Step 5
- Whole of design will be displayed.
- A part to be sewn at Step 5 will be displayed as enlarged image.
- When changing the value, if pressing the key longer, the value will be fast-forwarded.
- The item changed the value will turn to red character.
- Return the changed value to the initial value.
- Return all values changed at screen P1 and P2 to the initial values.

2015

4

12

5 / 32

875 st.

Jump 14 st.

Seq1 52

Seq2 38

6

7

8

9

10

11

10

12

13

14

15

17

16

1100 rpm

Maximum RPM
2250-1100 rpm? 1100 rpm

Auto Jump
(2.0-9.9 mm, No:A, B:240-360) No

Jump Convert
(No, Yes 1-9J) Yes JJ

Presser foot lower dead point
(0.3-5.3 mm) 0.5

Presser foot stroke
(A (Auto), 0.0-25.0 mm) 12

Presser foot timing
(-30-30) 0

Presser foot F.B. low
(Lower dead point 5.0-25.0 mm)

Thread breakage detection
(No, Yes, Boring) Yes

Return / Tie stitches
(No, Yes) Yes

P1 P2 P3 ALL One

Seqin Output 1 Sq1
?No, Sq1, Sq2?

Seqin Output 2 Sq2
?No, Sq1, Sq2?

Backlash (X) 0.0 mm
?-0.5- +0.5 mm?

Backlash (Y) 0.0 mm
?-0.5- +0.5 mm?

Satin stitch (area) Whole
(Whole, Part, No)

Satin stitch (density) 0.4 mm
?0.4- 1.0 mm?

Satin stitch (Expansion) 0.0 mm
?-1.0- +1.0 mm?

Start emb. presser stroke setting (0 ST) 0
(0-5st.)

Start emb. presser stroke setting (Auto) 0
(0-5st.)

The display will appear only when the functional limit level is set to "ALL Yes". (→ p.232)

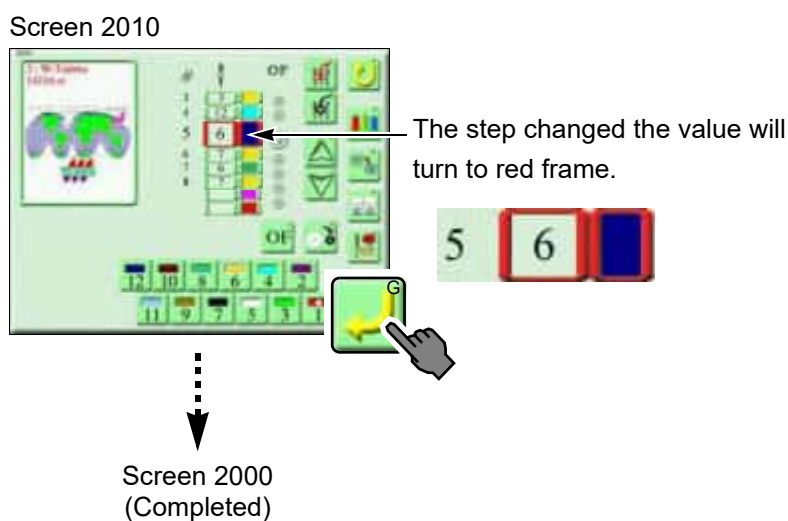

Stitching conditions are as shown in the chart below.

Page P1

Stitching condition	Setting range
Maximum RPM	250 rpm to Maximum r.p.m. of machine
Auto Jump	2.0-9.9 mm, No: A, B: 240-360
Jump Convert	No, Yes1-9J
Presser foot lower dead point	0.3 to 5.3 mm
Presser foot stroke	A (Auto), 0.0-25.0 mm
Presser foot timing	-30 - +30
Presser foot F.B. lower dead point	5.0 to 25.0 mm
Thread breakage detection	No, Yes, Boring
Return / Tie stitches	Yes, No

Page P2

Stitching condition	Setting range
Sequin Output 1	No, sq1, sq2
Sequin Output 2	No, sq1, sq2

Page P3

Stitching condition	Setting range
Start emb. presser stroke setting (0 ST) ^[1]	0 to 5 stitch
Start emb. presser stroke setting (Auto) ^[2]	0 to 5 stitch

[1]This function sets how many stitches are sewn at start of sewing in the state that the presser foot is lowered to the lower dead point. (usually "0")

[2]This function sets how many stitches are sewn by the presser foot with the maximum stroke after sewing the set value in [1] described above. (usually "1")

In addition, if both "0ST" and "AUTO" are set as 1 (stitch), the setting of "AUTO" will take priority.

[How to operate]

Set Step 5 to the following stitching condition.

- Needle bar No.: 9 (Changing from 6 to 9)
- Maximum RPM: 700 rpm
- Presser foot lower dead point: 3.0 mm
- Presser foot F.B. lower dead point: 5.0 mm

(1) Icon A

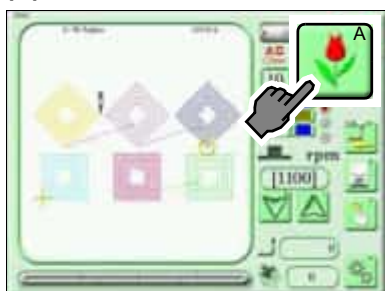

(2) Design

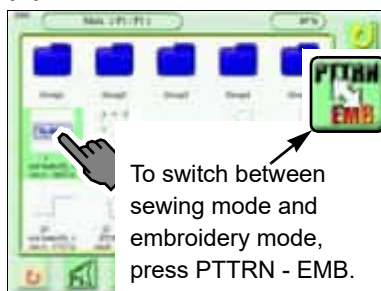

(3) Icon E

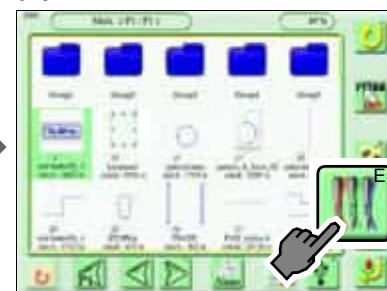

(4) Step 5

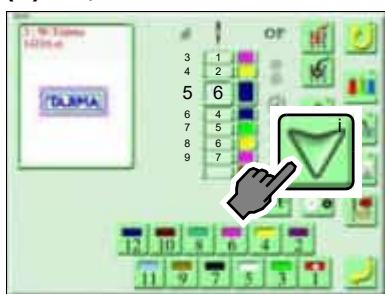

(5) Icon F

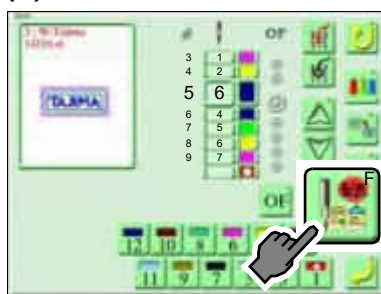

(6) Needle bar No. 9



(7) Maximum RPM

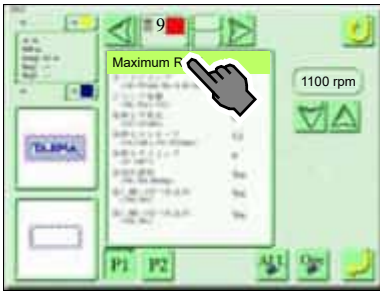

(8) 700 (rpm)

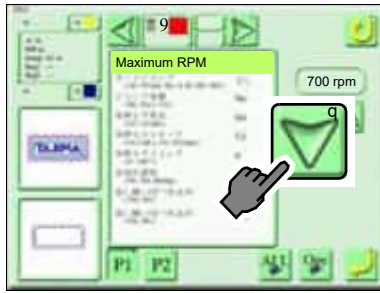

(9) To set

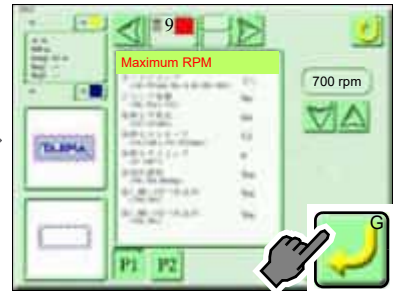

(10) Presser foot lower dead point

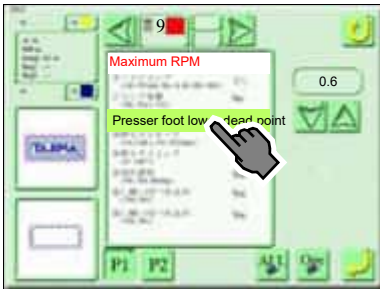

(11) 3.0 (mm)

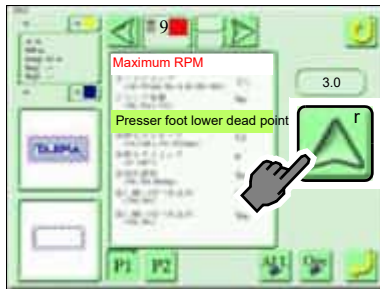

(12) To set

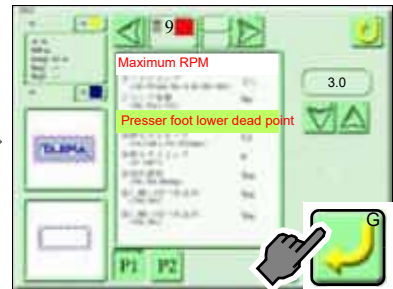

(13) Presser foot F.B. lower dead point

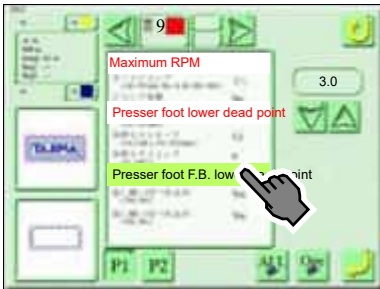

(14) 5.0 (mm)

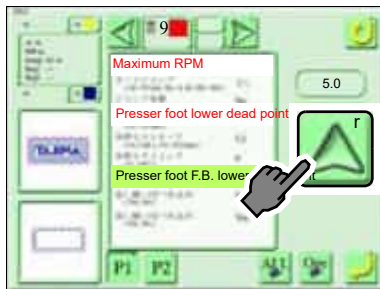

(15) To set

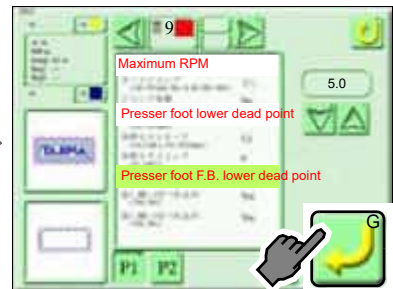

(16) Icon A

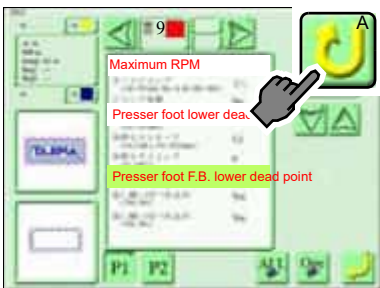

(17) To set (Completed)

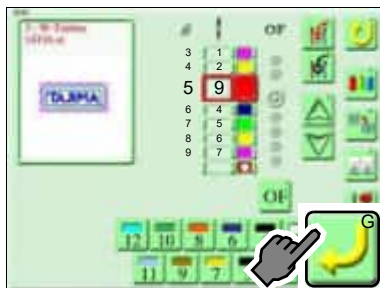

6-4. To replace specified needle bar No. with other needle bar No. in a batch (Needle bar conversion)

[How to operate]

Replace the needle bar No. 8 to the needle bar No. 6 in a batch.

Step No.	Needle bar No.		Needle bar No.
1	8	⇒	6
2	5		5
3	8	⇒	6
4	5		5
5	1		1
6	8	⇒	6

(1) Icon A

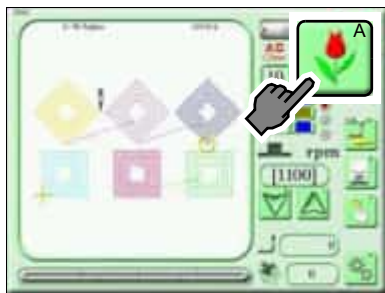

(2) Design

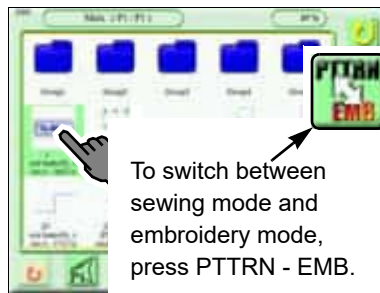

(3) Icon E

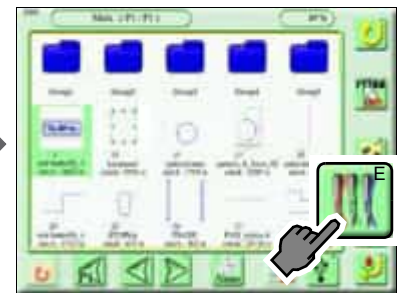

(4) Icon D

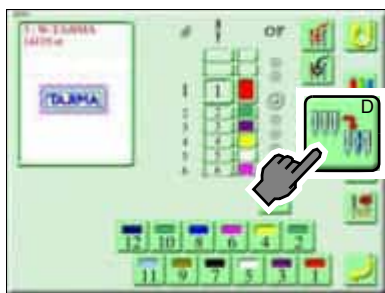

(5) Needle bar No. 8

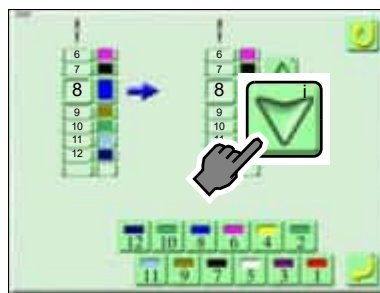

(6) Needle bar No. 6

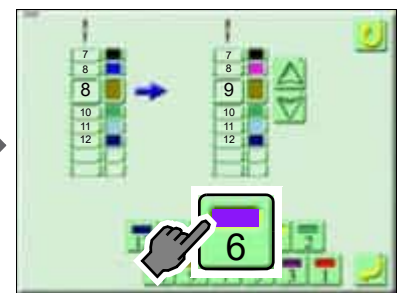

(7) To set (Completed)

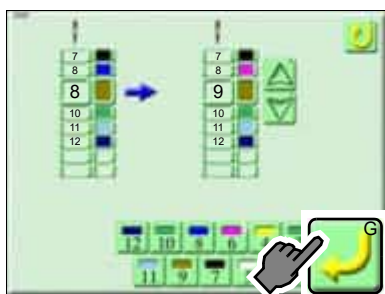

7. Needle bar color

7-1. To change the needle bar color

This function allocates the color you desire to each needle bar. The design data will be displayed with colors on the panel, so the image of the finish of sewing can be checked.

[How to operate]

Change the needle bar No. 1 to yellow, and the needle bar No. 5 to black.

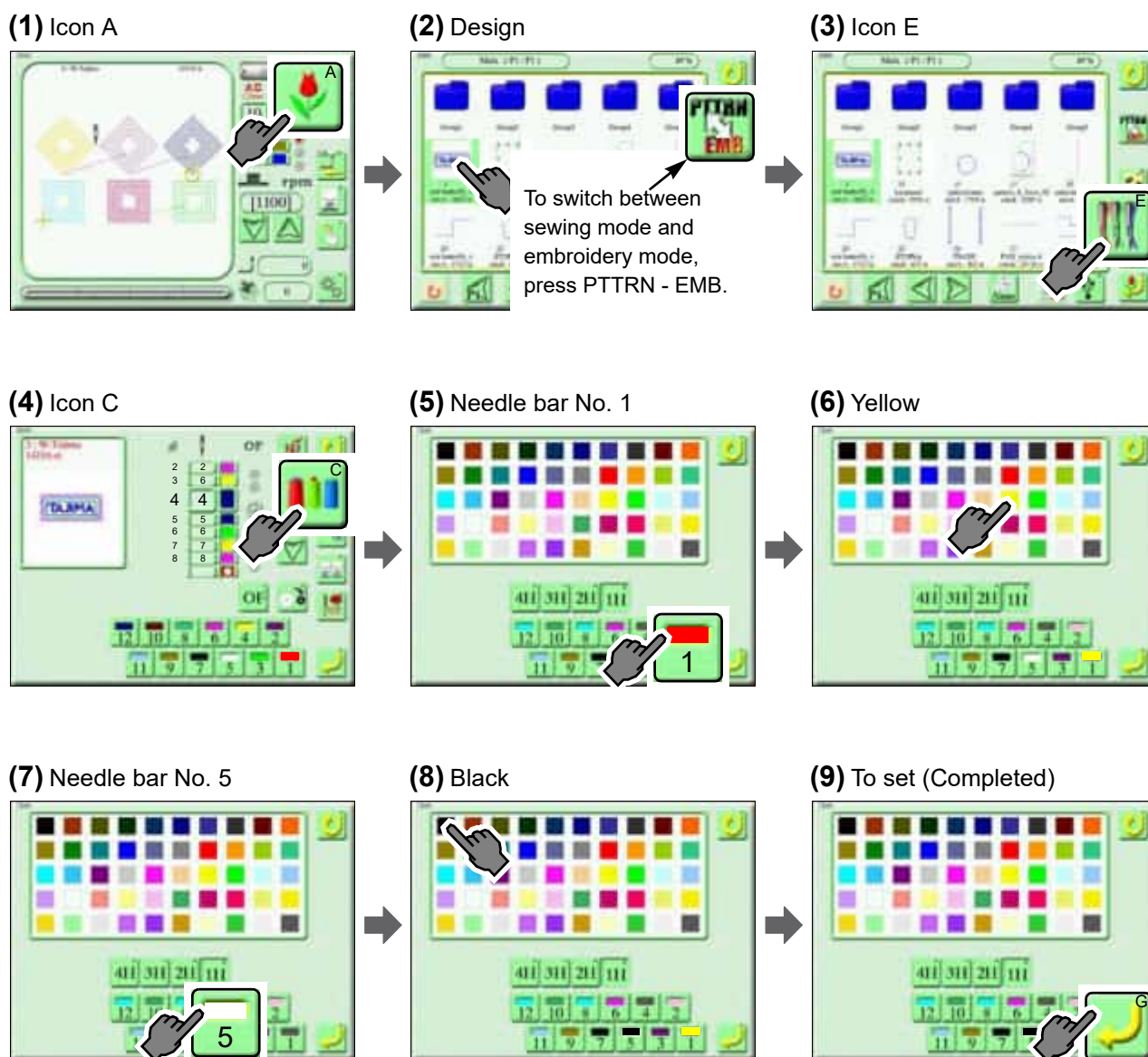

Chapter 9

Optional device

- 1. Sequin Device 220
- 2. Automatic Lubrication System 225

1. Sequin Device

1-1. To raise/lower all the Sequin devices of all heads at the same time

This function can be operated only when the needle bar equipped with the Sequin Device is selected.

⚠ CAUTION

- ⊘ When performing this operation, keep your hands, face etc. away from the needle bar case. A moving Sequin Device could injure you.
- ⊘ Do not raise/lower the air cylinder and its related parts by hand. It could damage the Sequin Device.

About Sequin Device IV operation

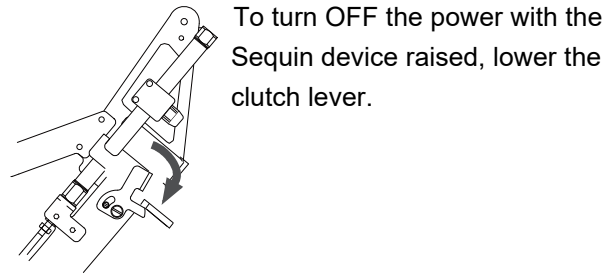
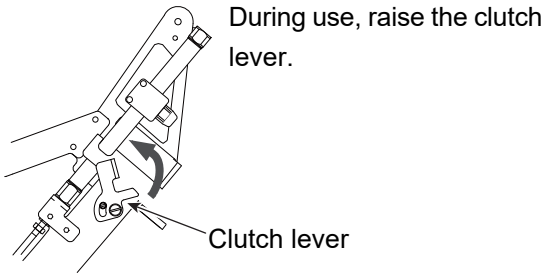

[How to operate]

Lower the Sequin Device.

(1) Icon F



(2) Icon e



(3) Icon W



(4) Yes (Completed)

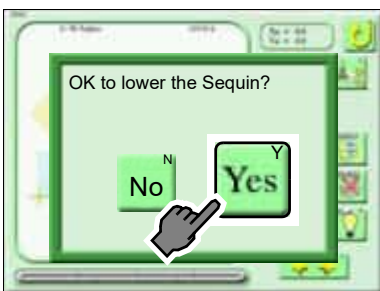

[How to operate]

Raise the Sequin Device.

(1) Icon F



(2) Icon e



(3) Icon X



(4) Yes (Completed)

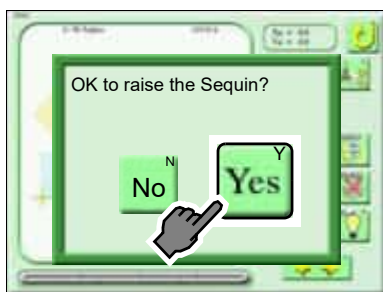

1-2. To raise/lower Sequin devices individually

This function supports the Sequin Device III only.

⚠ CAUTION

⊘ When performing this operation, keep your hands, face etc. away from the needle bar case. A moving Sequin Device could injure you.

Up/down switch

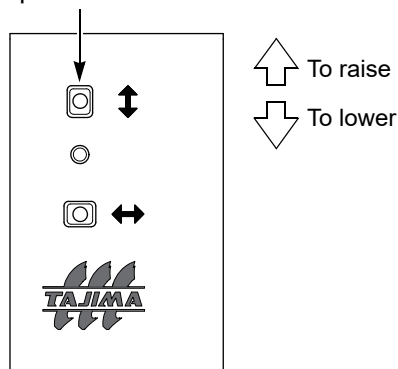

It is possible to operate only when the machine stops.

This function can be operated only when the needle bar equipped with the Sequin Device is selected.

Flipping the switch during raising/lowering will cause the device to stop.

1-3. To perform Color Change manually

This function supports the Sequin Device III only.



CAUTION

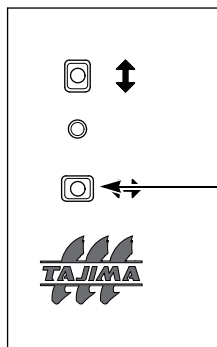

When performing this operation, keep your hands, face etc. away from the needle bar case. A moving Sequin Device could injure you.

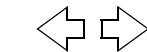

Color Change switch



It will slide right and left.

It is possible to operate only when the machine stops.

This function can be operated only when the needle bar equipped with the Sequin Device is selected.

1-4. To replace Sequin 1 with Sequin 2 (Step unit)

Reverse Sequin 1 and Sequin 2 of the Sequin Device by step unit. This function supports the Sequin Device III only.

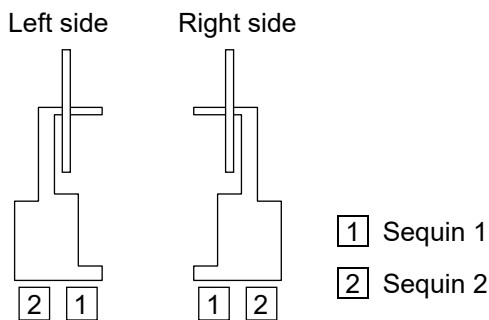

[How to operate]

Reverse sequin embroidery of step 6 at the right side Sequin Device.

(1) Icon A

(2) Design

To switch between sewing mode and embroidery mode, press PTTRN - EMB.

(3) Icon E

(4) Step 6

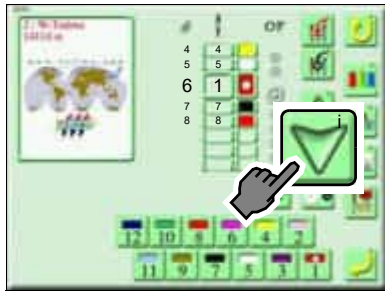

(5) Icon u

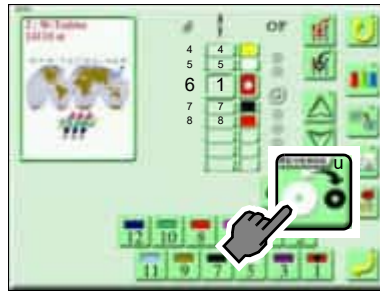

If icon u is pressed, the display of the needle bar icon of the 1st needle will be switched.

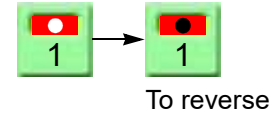

(6) Needle bar No. 1

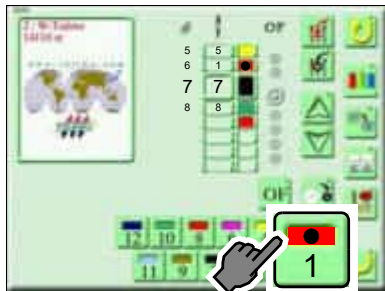

If the needle bar No.1 is pressed, step 6 will be switched on the display as shown below.

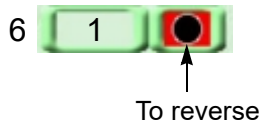

○ Not to reverse	Sequin 1 will be output by sequin output signal 1. Sequin 2 will be output by sequin output signal 2.
● To reverse	Sequin 2 will be output by sequin output signal 1. Sequin 1 will be output by sequin output signal 2.

(7) To set (Completed)

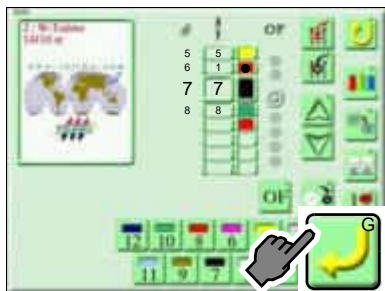

1-5. To replace Sequin 1 with Sequin 2 (Design data in a batch)

Reverse Sequin 1 and Sequin 2 of the Sequin Device together with the design data in a batch. After reversing, the design data will be overwritten. This function supports the Sequin Device III only.

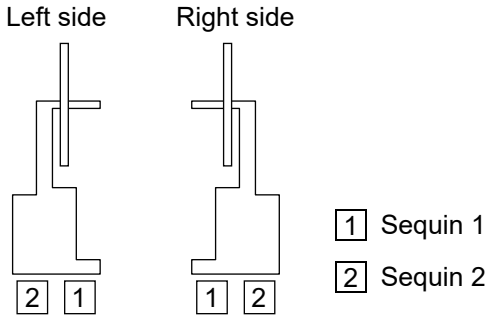

[How to operate]

Reverse sequin embroidery at the right side Sequin Device in a batch.

(1) Icon A

(2) Design

(3) IconD

(4) To set

(5) IconS

(6) Yes

(7) To set (Completed)

After that, perform the data set for this design.

2. Automatic Lubrication System

2-1. To operate Lubrication System

While the machine stops, operate the lubrication system manually to lubricate.

[How to operate]

(1) Icon F



(2) Icon e





(3) Icon T



(4) Yes (Completed)



 RH^d Lubricating rotary hook

 RH^u Lubricating rotary hook and head

Chapter 10

Parameter (Setting item)

[Important]

About parameter display on the operation panel

All parameters are explained in this chapter. However, some parameters, which could affect sewing quality if they are changed easily, are set to be hidden at shipment and they can not be changed.

For details of the password, consult the distributor.

1. Display setting of parameter	228
2. Parameter	233



1. Display setting of parameter

This machine is shipped as the functional limit level "1". Display or hide parameters by the following operation according to the necessity of your use.

1-1. You want to hide all parameters.

From the state of the functional limit level "1", we explain operating method hereafter.

(1) Icon G



(2) Press P6 twice.

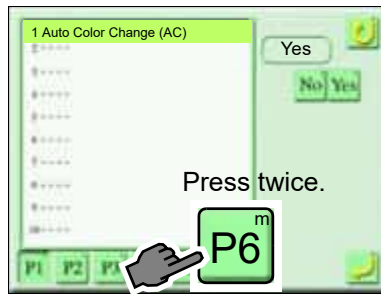

(3) Icon S

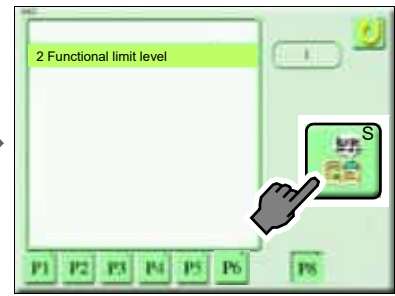

(4) Input a password.



(5) To set



(6) Functional Limit Level 2

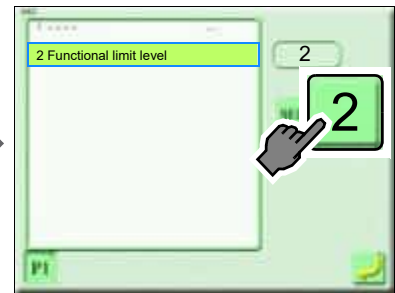

(7) To set

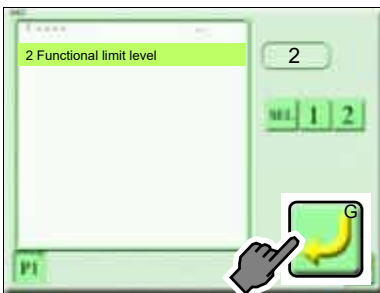

(8) Icon A (Completed)

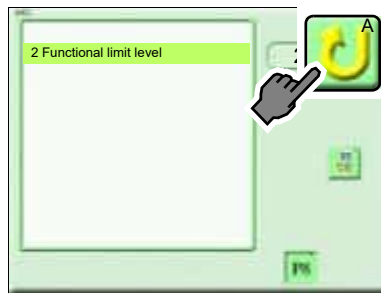



You want to display the desired parameter only.

1-2. You want to display the desired parameter only.

From the state of the functional limit level "1", we explain operating method hereafter.

[An example of operation]

You want to display only "1 Auto Color Change (AC)" and "2 Auto Start".

(1) Icon G



(2) Press P6 twice.

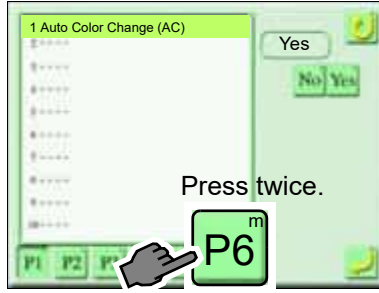

(3) Icon S

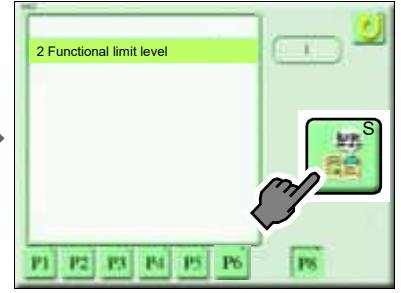

(4) Input a password.



(5) To set



(6) SEL

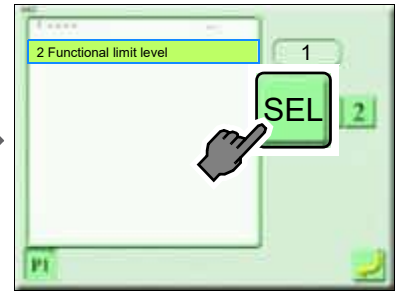

(7) Icon T

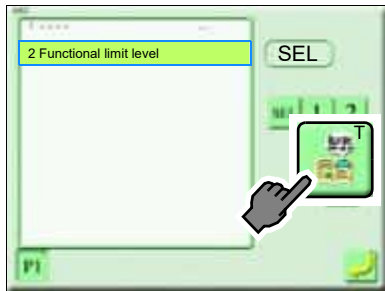

(8) ALL No

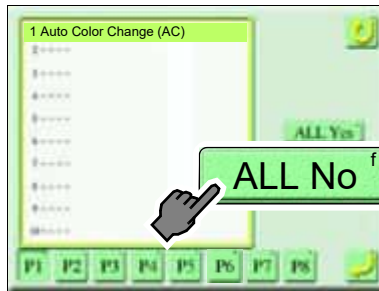

Outer frame turns yellow during setting level SEL.



(9) 1 Auto Color Change (AC)

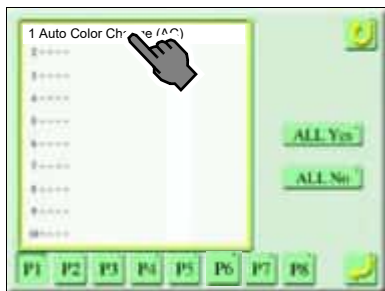

(10) 2 Auto Start (AS)

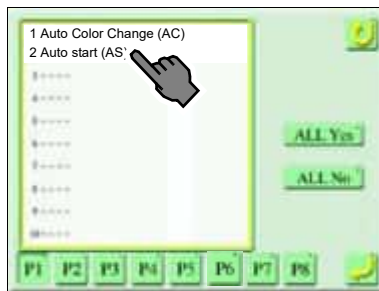

(11) To set

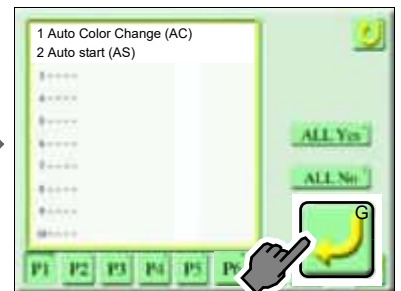



(12) To set

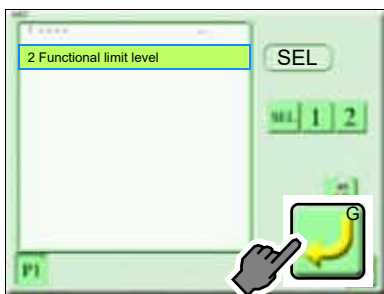

(13) Icon A (Completed)

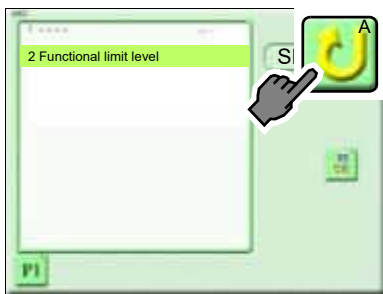

1-3. You want to hide the desired parameter only.

From the state of the functional limit level "1", we explain operating method hereafter.

[An example of operation]

You want to hide only "9 Auto Jump" and "10 Jump Convert".

(1) Icon G



(2) Press P6 twice.

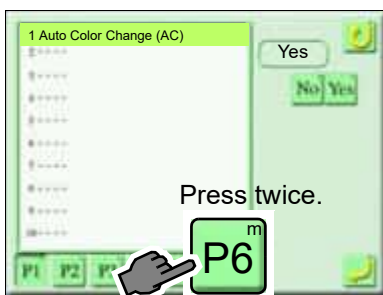

(3) Icon S

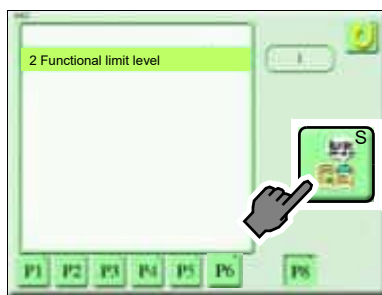

(4) Input a password.



(5) To set



(6) SEL

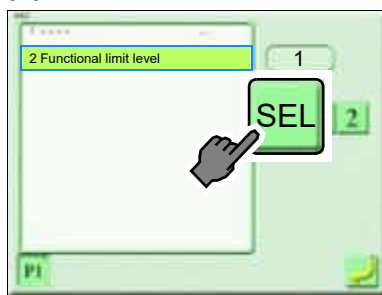

(7) Icon T

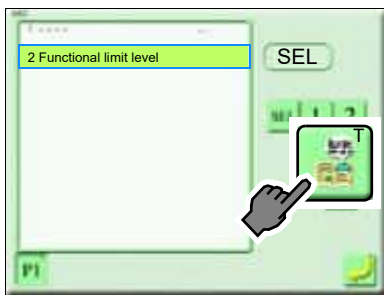

(8) ALL Yes

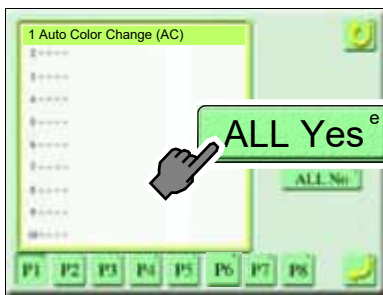

Outer frame turns yellow during setting level SEL.





You want to hide the desired parameter only.

(9) 9 Auto Jump

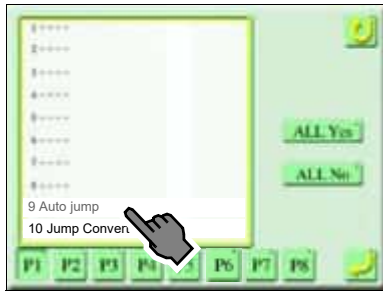

(10) 10 Jump Convert



(11) To set

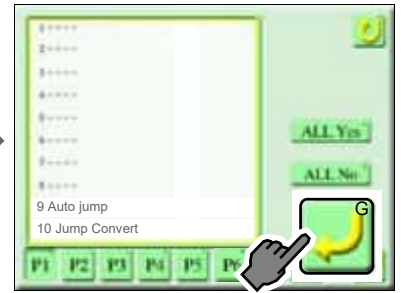

(12) To set

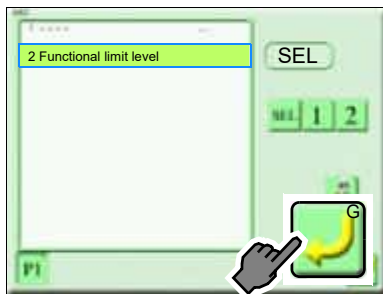

(13) Icon A (Completed)

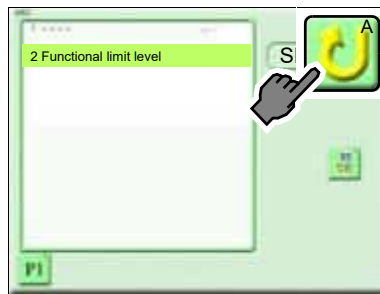



1-4. You want to display all parameters.

From the state of the functional limit level "1", we explain operating method hereafter.

(1) Icon G



(2) Press P6 twice.

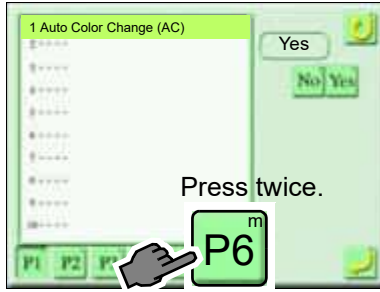

(3) Icon S

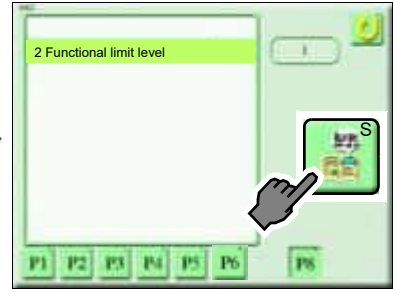

(4) Input a password.

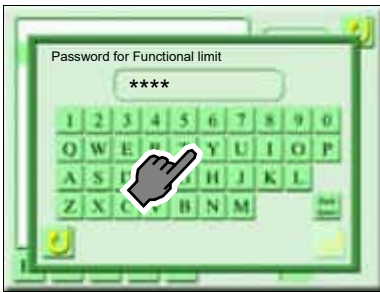

(5) To set



(6) SEL

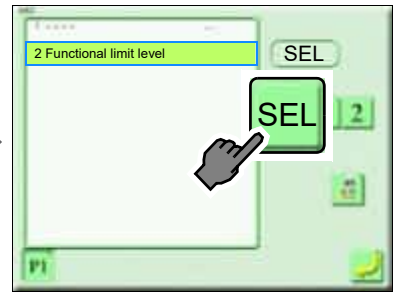

(7) Icon T

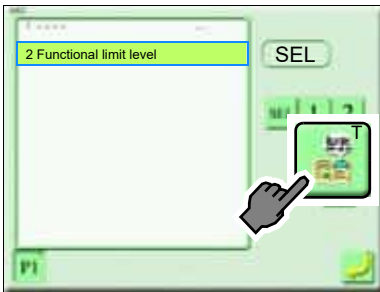

(8) ALL Yes

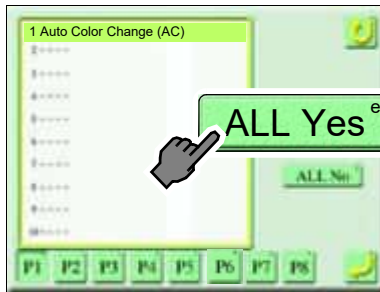

(9) To set

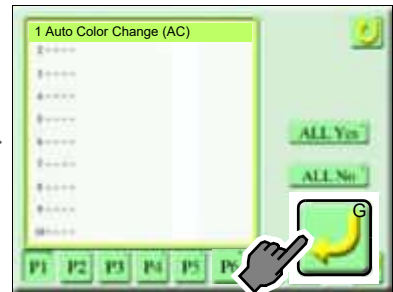

(10) To set

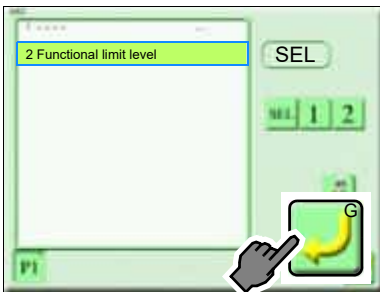

(11) Icon A (Completed)

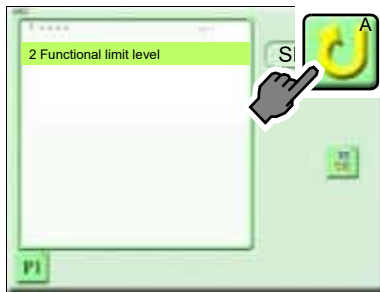

2. Parameter

2-1. Page P1

[How to switch to page P1]

(1) Icon G



(2) Page P1



1 Auto Color Change (AC)

This is the setting to change the color automatically according to "Color change sequence".



Setting range

Yes: Auto Color Change is performed.

No: Auto Color Change is not performed.

Example: Yes

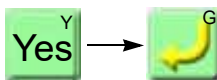

2 Auto Start (AS)

This is the setting to start the operation automatically after color change.



Setting range

Yes: Auto start is performed.

No: Auto start is not performed.

Example: Yes

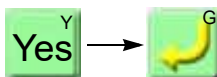

3 Auto start at same color

This is the setting to start the operation automatically even if the same needle bar is selected before and after color change.



Setting range

Yes: Auto start is performed.

No: Auto start is not performed.

If "No" is selected, the machine will stop when the same needle bar is selected before and after color change.

Example: No

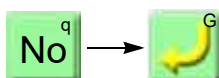

4 Auto Start after auto data set

CAUTION

After sewing is finished, do not put your hands etc. on the table. Automatic start operation could injure you.

This is the setting to perform automatic start after sewing is completed and sew the same design repeatedly.



Setting range

Yes: Automatic operation is started after stitching is finished.

No: Automatic operation is not started after stitching is finished.

Example: No

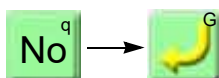

5 Frame Type (Setting for border frame only)

CAUTION

When performing this operation, do not put your hands, etc. on the table. Moving the frame could injure you.

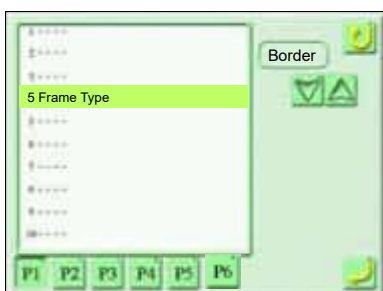

Setting range
Border frame

6 Total Stitch Counter

Display the time from start of operation to now, the number of sewn stitches, the number of designs and remaining amount to Preset Halt.



Example: Reset a design counter.

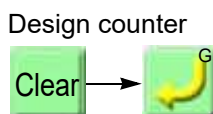

7 Main Shaft Inching

After stopping the machine during embroidery, set the number of time of lowering the needle bar at slow operation performing when the operation starts again.

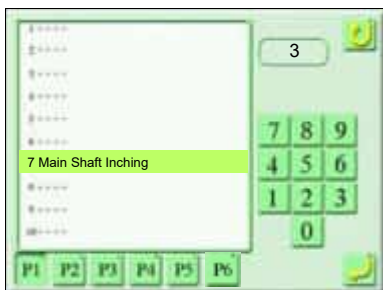

Setting range: 0 to 9 times

Example: 3 times

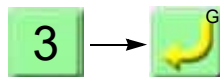

8 M.shaft Inching after ATH

Set times of lowering the needle bar by slow operation performed when starting operation again after data set and thread trimming. It is possible to set at embroidery mode and sewing mode by each needle bar.



Setting range

M.H (Embroidery mode), H.H (Sewing mode)

Any: All needles in a batch

1st to last needle: Needle bar No.

2 to 9: Times of lowering needle bar by operating slowly

Example: Set all needle bars to "Three times" in sewing mode.



Setting of all needles in a batch

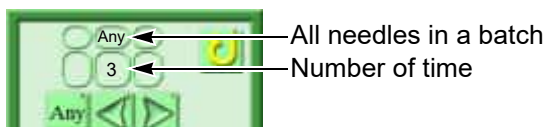

Setting for each needle bar

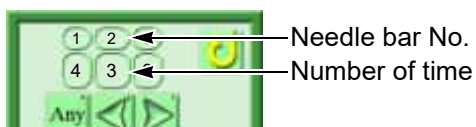

9 Auto jump

This is the setting to perform jump automatically when stitch length is longer than the setting value. There are two types of auto jump, A (Split auto jump) and B (Batch auto jump).

When the setting of Auto jump has been changed by "Step unit setting" individually, the value of "Step unit setting" will take the priority.

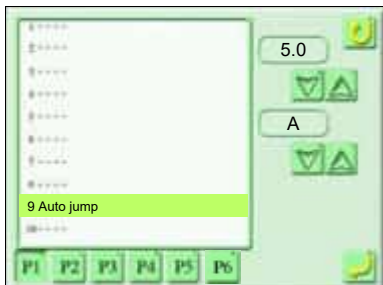

Setting range

No: Auto jump is not performed.

2.0 to 9.9 mm: Automatic jump is performed.

A: Split auto jump

B: Batch auto jump

240 to 360°: Frame Start Timing

Yes: R.P.M. Keep is performed.

No: R.P.M. Keep is not performed.

Example: Set stitch length to 5.0 mm, and set to A (Split auto jump).

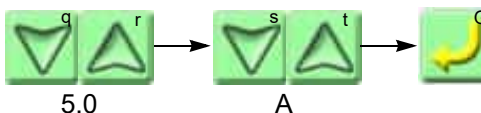

If B(Batch auto jump) was selected, press the icon T, and select Frame start timing and R.P.M. Keep.



10 Jump Convert

This is the setting to trim thread and move the frame to next stitch when jump codes continue more than the set times,

When the setting of Jump convert has been changed by "Step unit setting" individually, the value of "Step unit setting" will take the priority.

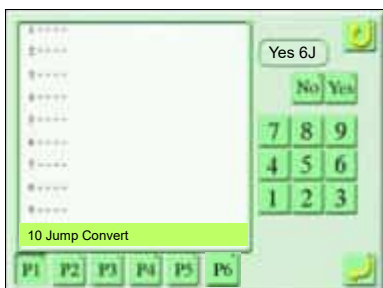

Setting range

Yes: Jump convert is performed. (1 to 9 times)

No: Jump convert is not performed.

Example: Set consecutive jump codes to 6 times.

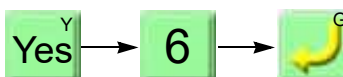

2-2. Page P2

[How to switch to page P2]

(1) Icon G



(2) P2

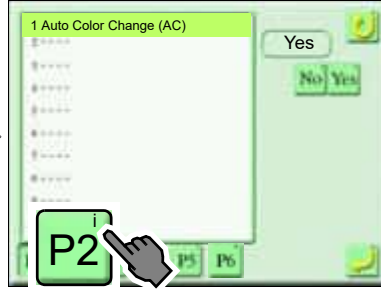

(3) Page P2

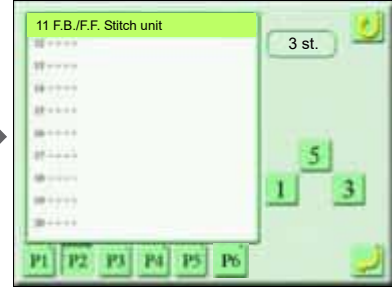

11 F.B./F.F. Stitch unit

Set frame feed amount when performing Frame back or Frame forward by 11 stitches or more.



Setting range: 1, 3, 5 stitches

Example: Set feed amount to 5 stitches.

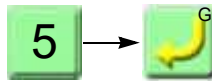

12 Auto F.B. after T. detection

This is the setting to perform Frame Back automatically at thread breakage.



Setting range

Yes: Auto F.B. is performed.

0 to 9: Number of stitches performing frame back

No: Auto F.B. is not performed.

The number of stitches to perform Frame Back is the total of this value and the value of "26. Upper thread detection" or "27. Under thread detection (unit)" of page P3 based on the stop point of the machine.

Example: Perform Frame Back by 4 stitches.

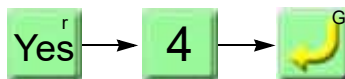

13 Overlap Frame Back

Set a start position of embroidering at all heads after Frame back.



Setting range

Yes: All heads start embroidery.

If "Yes" is selected, set All Head Sewing Start Point.

1: All heads start embroidering from the position where is one stitch prior to the start position of Frame back.

2: All heads start embroidering from the position where is two stitches prior to the start position of Frame back.

3 to 9:

All heads start embroidering from the position where is 3 to 9 stitches prior to the start position of Frame back.

Whole area: Embroider at whole area of Frame back section by all heads.

No: Overlap frame back at all heads is not performed.

Example: Embroider from the position where is 3 stitches prior to the start position of Frame back at all heads.

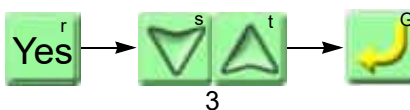

14 Halt before F.B./inching

Set a starting method to start embroidering at all heads after Frame back.

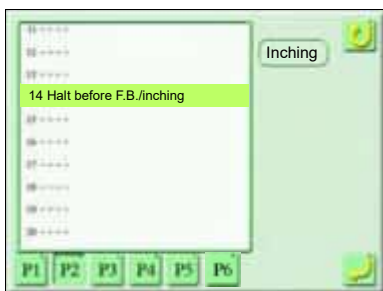

Setting range

Stop: Stop at the position where all heads start embroidering

15 R.P.M. limit by needle position

Set the maximum speed by all needles in a batch or by needle bar unit. When Sequin device is equipped, set the maximum speed of Sequin device.

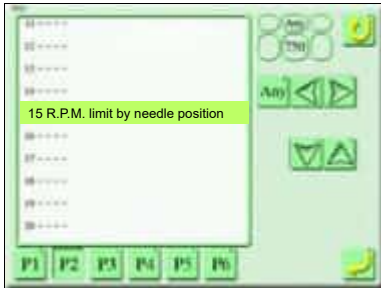

Setting range

- Any: All needles in a batch
- 1st to last needle: Needle bar No.
- 250 or over: Maximum r.p.m of machine

Example: Set 8th needle to 1000 rpm.

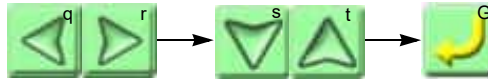

Needle bar No. 8 1000

16 Presser foot lower dead point

Set the distance between the presser foot and the needle plate when the presser foot goes down to the lower dead point. It is possible to set by all needles in a batch or by needle bar unit.

When the setting of Presser foot lower dead point has been changed by "Step unit setting" individually, the value of "Step unit setting" will take the priority.

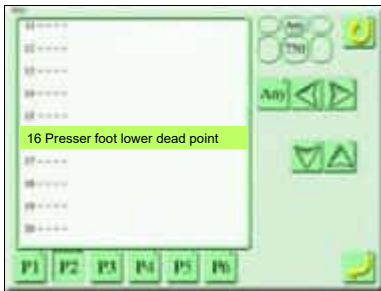

Setting range

- Any: All needles in a batch
- 1st to last needle: Needle bar No.
- 0.3 to 5.3: Presser foot lower dead point (mm)

When Multi Cording Device is equipped, "Any" (all needles in a batch) icon will be not displayed, and only the setting of needle bar unit is available.

Example: Set Presser foot lower dead point of 3rd needle to 0.5 mm.

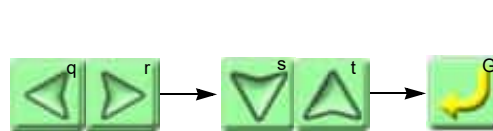

Needle bar No.3 0.5

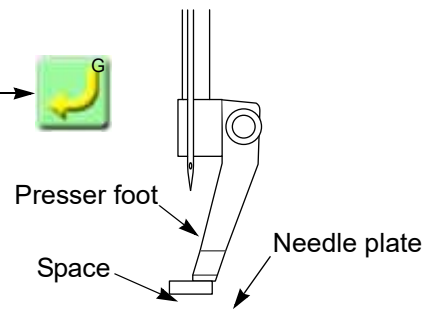

17 Presser foot stroke

Set stroke amount of the presser foot . It is possible to set by all needles in a batch or by needle bar unit. This function is effective only when "19 Presser foot stroke mode" is set to "M".

When the setting of Presser foot stroke has been changed by "Step unit setting" individually, the value of "Step unit setting" will take the priority.



Setting range

Any: All needles in a batch

1st to last needle: Needle bar No.

0.0 to 25.0: Presser foot stroke (mm)

When Multi Cording Device is equipped, "Any" (all needles in a batch) icon will be not displayed, and only the setting of needle bar unit is available.

Example: Set Presser foot stroke amount of 3rd needle to 18.0 mm.

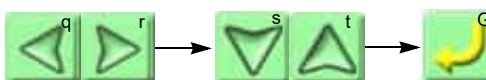

Needle bar No.3

18.0

18 Presser foot timing

Set the timing when the presser foot goes down. It is possible to set by all needles in a batch or by needle bar unit. The initial value is 0. It is not necessary to change this value in usual use.

When the setting of Presser foot timing has been changed by "Step unit setting" individually, the value of "Step unit setting" will take the priority.



Setting range

Any: All needles in a batch

1st to last needle: Needle bar No.

-30 to 30: Presser foot timing

Example: Set Presser foot timing of 3rd needle to 10.

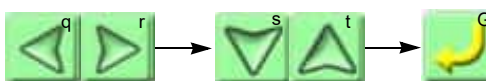

Needle bar No.3

10

19 Presser foot stroke mode

Set Stroke mode of the presser foot . It is possible to set by all needles in a batch or by needle bar unit. When the setting of Presser foot stroke mode has been changed by "Step unit setting" individually, the value of "Step unit setting" will take the priority.

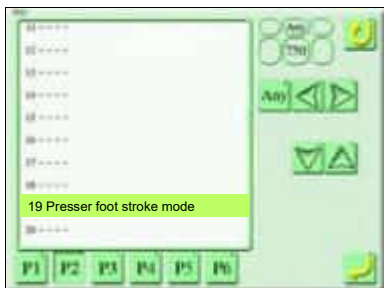

Setting range

Any: All needles in a batch

1st to last needle: Needle bar No.

A: Automatic

According to maximum speed of the machine, the presser foot will perform Stroke automatically (usual setting).

M: Manual

The maximum speed of the machine is limited depending on stroke amount. (The stroke amount is always fixed.)

Select "M" when sewing thick fabric mainly.

Example: Set 3rd needle to M.

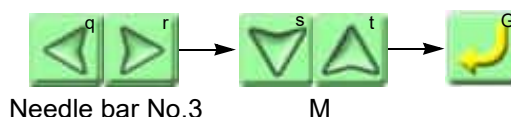

20 Presser foot F.B. lower dead point

Set a presser foot lower dead point at Frame Back. It is possible to set by all needles in a batch or by needle bar unit.

When the setting of Presser foot F.B. lower dead point has been changed by "Step Unit Setting" individually, the value of "Step unit Setting" will take the priority.

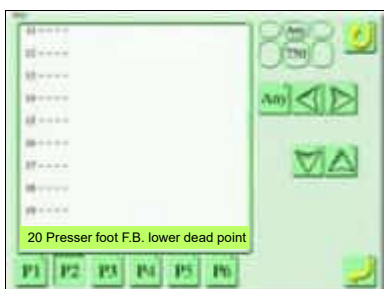

Setting range

Any: All needles in a batch

1st to last needle: Needle bar No.

5.0 to 25.0: Presser foot lower dead point

Example: Set all needles to 10.0 mm.

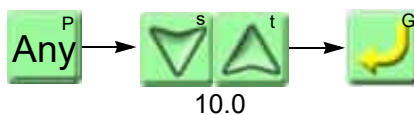

2-3. Page P3

[How to switch to page P3]

(1) Icon G



(2) P3

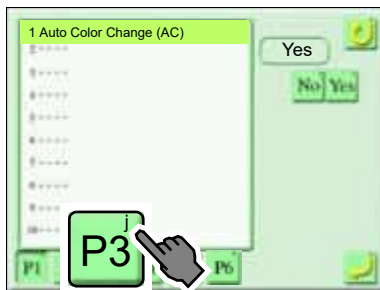

(3) Page P3

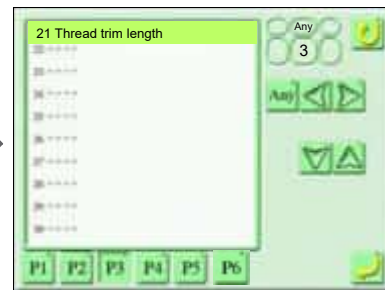

21 Thread trim length

Adjust the remaining length of the upper thread after thread trimming by all needles in a batch or by needle bar unit.



Setting range

Any: All needles in a batch

1st to last needle: Needle bar No.

SS, S, M, L, LL: Remaining length

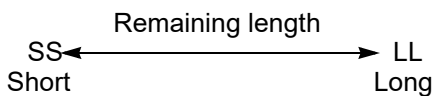

Example: Set all needle bars to "S".

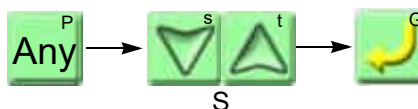

22 Picker movement at start of emb.

Set the picker movement at start of embroidery by all needles in a batch or by needle bar unit.

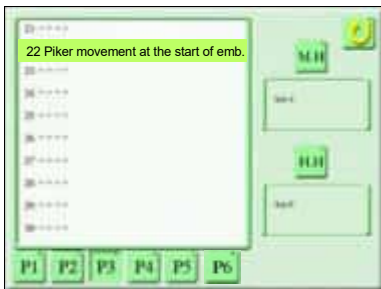

Setting range

M.H (Embroidery mode), H.H (Sewing mode)

Any: All needles in a batch

1st to last needle: Needle bar No.

Yes: The picker will move.

No: The picker will not move.

Example: Set to 4th needle "Not to perform Picker movement" in sewing mode.

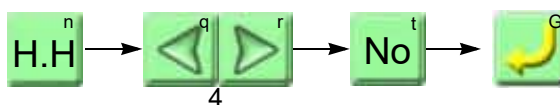

Setting of all needles in a batch

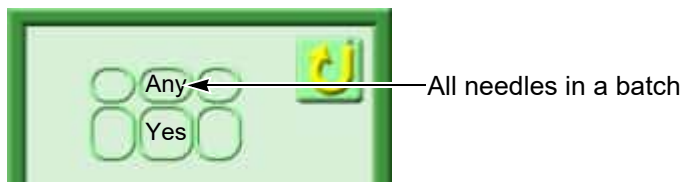

Setting for each needle bar

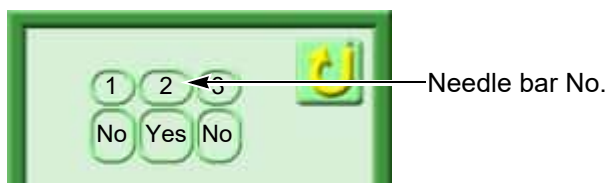

23 Return Stitches/Condensation

(1) Return Stitches

Set the number of Return stitches and stitch length to be performed at start of sewing by all needles in a batch or by needle bar unit. When the setting of Return stitches has been changed by "Step Unit Setting" individually, the value of "Step Unit Setting" will take the priority.



Setting range

Return Stitches

Any: All needles in a batch

1st to last needle: Needle bar No.

The number of Return Stitches

No: Return stitching is not performed.

1: One reciprocation of return stitching is performed.

2: Two reciprocations of return stitching is performed.

V: Number of setting stitches on a straight line

Z: One reciprocation for the number of setting stitches on a straight line

W: Two reciprocations for the number of setting stitches on a straight line

For V, Z and W, refer to the detail page.(→p.58)

Stitch length (only in case of 1 and 2)

0.6, 0.8, 1.0, 1.2, 1.6, 2.0: Stitch length (mm)

Stitch count (only in case of V, Z and W)

1 to 9 (Needle)

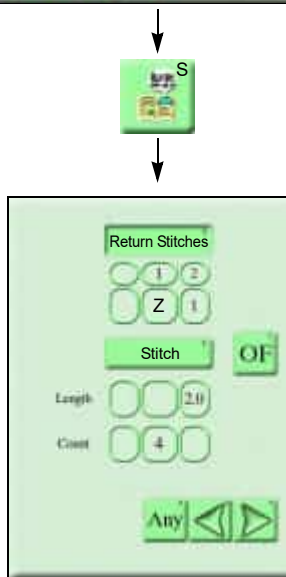

Example: Set to 2nd needle, Return stitch one time and 2.0 mm of stitch length.

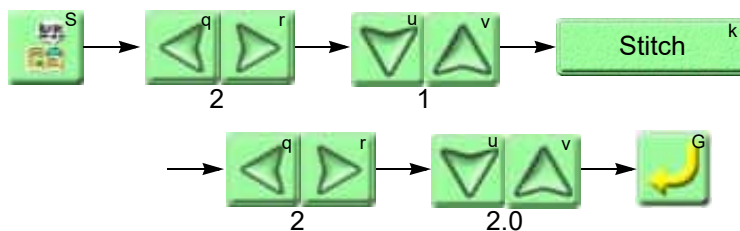

(2) Condensation sewing

Set Condensation sewing to be executed at start of sewing by all needles in a batch or by needle bar unit.

For this function, refer to the detail page.(→p.59)

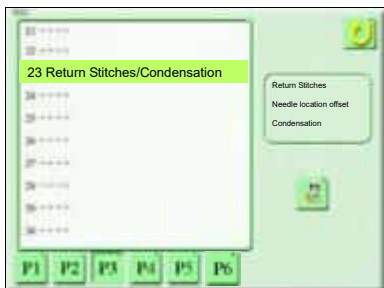

Setting range

Condensation sewing

Any: All needles in a batch
 1st to last needle: Needle bar No.

Number of needle of Condensation

No: Condensation sewing is not performed.
 1 to 9: Number of needle

Stitch Length

0.1 to 12.7: Stitch length (mm)

Only the stitch length shorter than that of the original design is displayed.

Example: Set to 2nd needle, Condensation 3 stitches and 1.5 mm of stitch length.

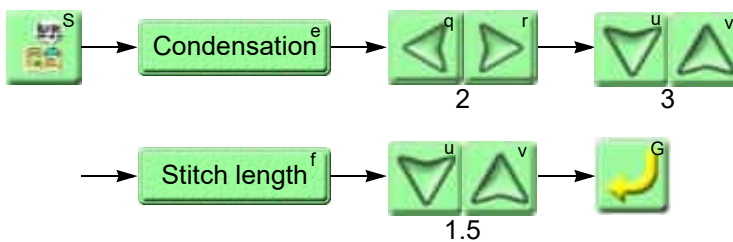

24 Tie Stitches/Condensation

(1) Tie stitches

Set Tie stitches and stitch length to be executed at sewing end by all needles in a batch or by needle bar unit.

When the setting of Tie stitches has been changed by "Step unit setting" individually, the value of "Step unit setting" will take the priority.

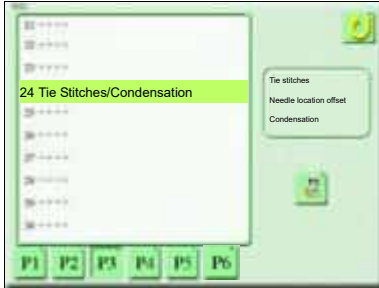

Setting range

Tie stitches

Any: All needles in a batch

1st to last needle: Needle bar No.

Tie stitching methods

No: Tie stitching is not performed.

B: Tie stitching is performed.

C: After embroidering 2 stitches at the same place, tie stitching will be performed.

D: Tie stitching will be performed twice.

E: B and D are switched to the direction of Tie stitches.

V: Number of setting stitches on a straight line

Z: One reciprocation for the number of setting stitches on a straight line

W: Two reciprocations for the number of setting stitches on a straight line

For V, Z and W, refer to the detail page. (→p.58)

Stitch length (only in case of B, C, D and E)

0.4, 0.6, 0.8,

1.0, 1.2, 1.6, 2.0: Tie Stitch length (mm)

Stitch count (only in case of V, Z and W)

1 to 9 (Needle)

Example: Set to 2nd needle, Tie stitch B and 0.6 mm of stitch length.

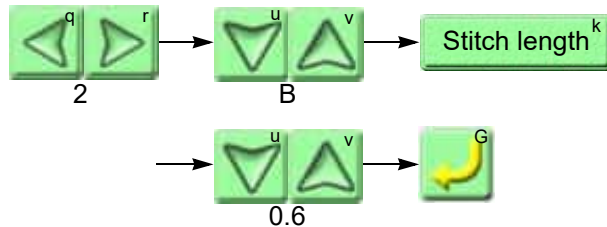

(2) Condensation sewing

Set Condensation sewing to be executed at sewing end by all needles in a batch or by needle bar unit.
For this function, refer to the detail page.(→p.59)

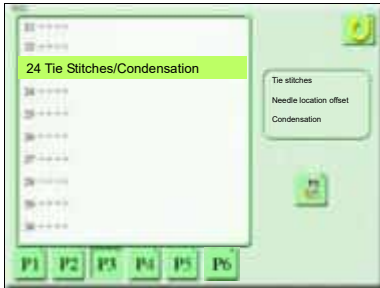

Setting range

Condensation sewing

Any: All needles in a batch

1st to last needle: Needle bar No.

Number of needle of Condensation

No: Condensation sewing is not performed.

1 to 9: Number of needle

Stitch length

0.1 to 12.7: Stitch length (mm)

Only the stitch length shorter than that of the original design is displayed.

Example: Set to 2nd needle, Condensation 3 stitches and 1.5 mm of stitch length.

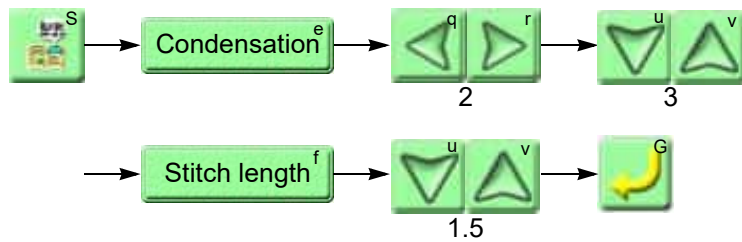

25 Upper thread lock timing

Set remaining length of the upper thread at start of embroidery (Release) and at thread trimming (Lock).

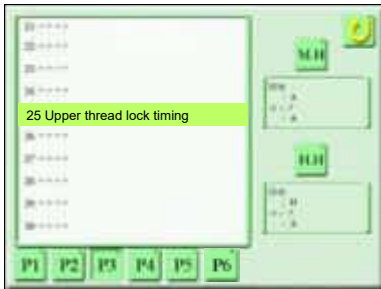

Setting range

M.H (Embroidery mode), H.H (Sewing mode)

Release: A, B, C, D

Lock: A, B, C, D

Example: Set "Release" to C in sewing mode.

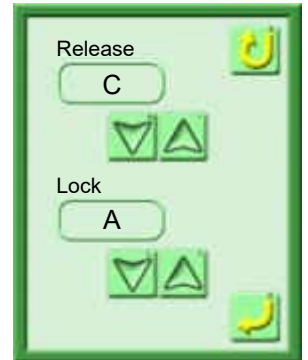
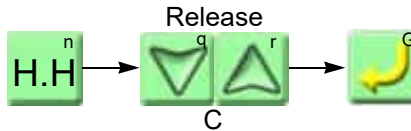

- A Upper thread is easy to remain
- B
- C ↓ Upper thread is hard to remain
- D When using thick thread, stuck of thread, etc in the rotary hook is avoided.

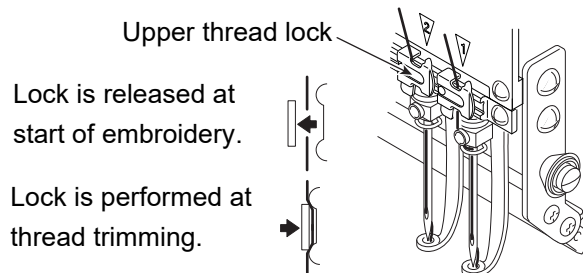

26 Upper thread detection

Set the sensitivity of detection when the thread breaks by all needles in a batch or by needle bar unit. When the setting of Thread breakage detection has been changed by "Step unit setting" individually, the value of "Step unit setting" will take the priority.

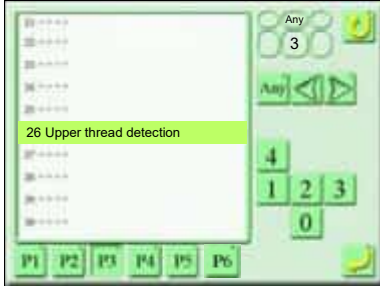

Setting range

Any: All needles in a batch

1st to last needle: Needle bar No.

0 to 4: Number of detecting times

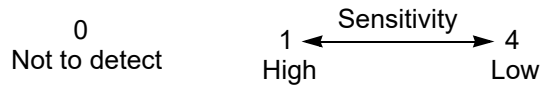

If the detecting time is set to "3", the machine will stop working when detecting thread breakage three times.

Example: Set all needle bars to three times.

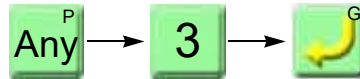

27 Under thread detection

(1) Unit

Set how many consecutive times of detecting of "Step ratio" are regarded as thread breakage by all needles in a batch or by needle bar unit.

When the setting of Thread breakage detection has been changed by "Step unit setting" individually, the value of "Step unit setting" will take the priority.

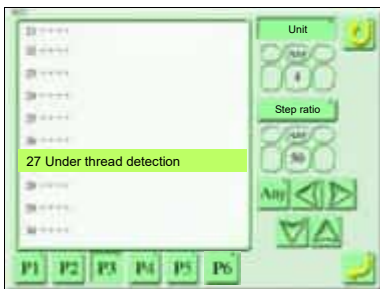

Setting range

Any: All needles in a batch

1st to last needle: Needle bar No.

0, 2, 4, 6, 8: Number of detecting times

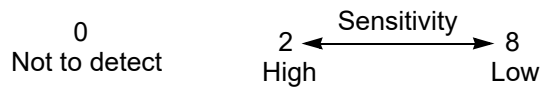

If the detecting time is set to "2", the machine will stop working when detecting "Step ratio" twice.

Example: Set all needle bars to two times.



(2) Step ratio

Set the detection sensitivity when under thread breaks by all needles in a batch or by needle bar unit.

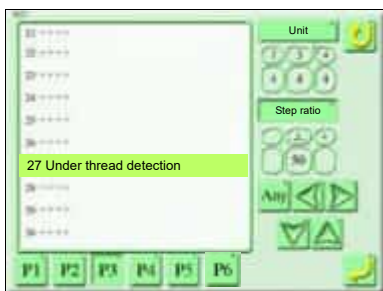

Setting range

Any: All needles in a batch

1st to last needle: Needle bar No.

30 to 100: Step ratio of detection (%)

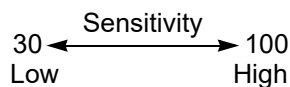

Example: Set all needle bars to 60%.

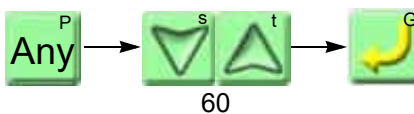

28 Upper thread binding at start of emb.

Set the detection sensitivity of binding of upper thread by all needles in a batch or by needle bar unit.

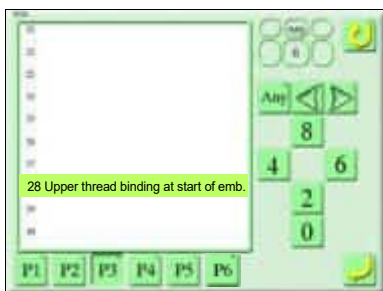

Setting range

Any: All needles in a batch

1st to last needle: Needle bar No.

0, 2, 4, 6, 8: Number of detecting times

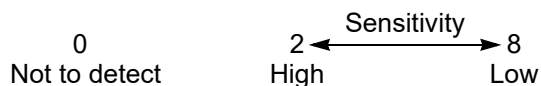

If the detecting time is set to "6", the machine will stop working when detecting binding of upper thread six times.

Example: Set all needle bars to six times.

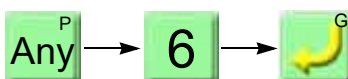

29 Auto origin return

This is the setting to return the frame to the start position after sewing is completed.

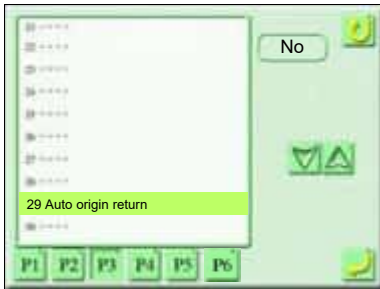

Setting range

No: Start position is not returned.

Linear travel:

Frame travel is performed within the shortest distance.

Linear travel after Origin Search:

After executing Absolute Origin Search, Frame Travel is performed within the shortest distance.

Reverse return:

Return the frame stitch by stitch.

Example: Linear travel

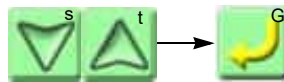

Linear travel

30 Return the frame after manual frame travel

This is the setting to return the frame to the previous position by the bar switch or the start switch operation after moving the frame in the middle of sewing.

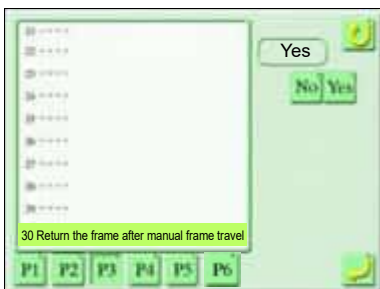

Setting range

Yes: The frame is returned to previous position.

No: The frame is not returned to previous position.

If "No" is selected, "Automatic data point return" will be invalid. In this case, the frame will not return and stitching will be started from the position after the frame moving by switch operation.

Example: Yes

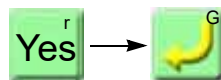



2-4. Page P4

[How to switch to page P4]

(1) Icon G



(2) P4

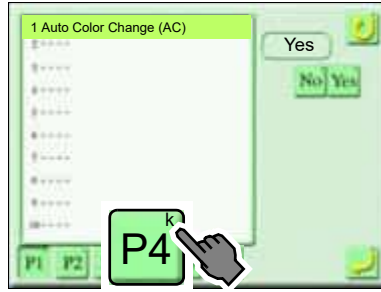

(3) Page P4

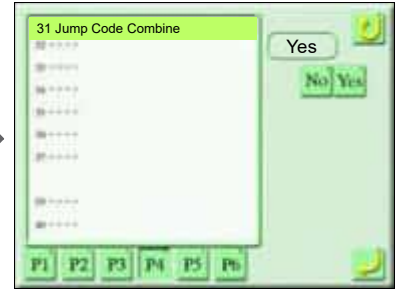

31 Jump Code Combine

This is the setting to combine moving amount of consecutive jump and to feed the frame all at once. It is possible to combine until moving amount becomes 36.0 mm.

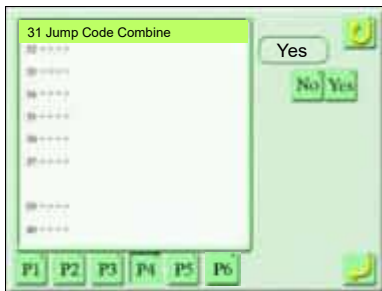

Setting range

Yes: Jump Code Combine is performed.

No: Jump Code Combine is not performed.

Example: Yes

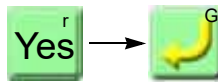

32 Language

Switch the language display of screen.



Example: English

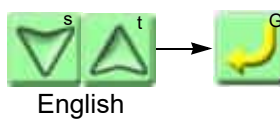

33 Preset Halt by stitches

This is the setting to stop the machine automatically when the number of stitches are reached to setting value.



Setting range: 0 to 999,999 stitches

Example: Stop at 5000 stitches.



After stop, "1D2" will be displayed.

34 Preset Halt by Data

This is the setting to make the machine to stop automatically when the cumulative amount of frame travel is reached to setting value.



Setting range: 0 to 99,999 cm

Example: Stop at 1,000 cm.



After stop, "1D2" will be displayed.

35 Preset Halt by Designs

This is the setting to make the machine to stop automatically when the cumulative number of sewing designs is reached.



Setting range: 0 to 999 designs

Example: Stop at 50 designs.

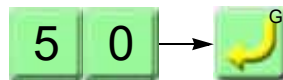

After stop, "1D2" will be displayed.

36 Preset Halt by Lubrication

This is the setting to stop the machine automatically when the number of stitches are reached to setting value.

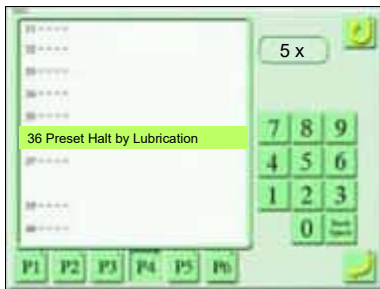

Setting range: 0 to 990,000 stitches

Example: Stop at 50,000 stitches.

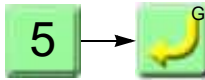

The setting value x 10,000 stitches is the number of stitch to stop. After stop working, "OIL" will be displayed. It is effective only when the setting of "9 Automatic lubrication system" of page P7 is "No".

37 Preset halt (1st before end code)

This is the setting to stop the machine automatically at the position where one stitch before sewing end.

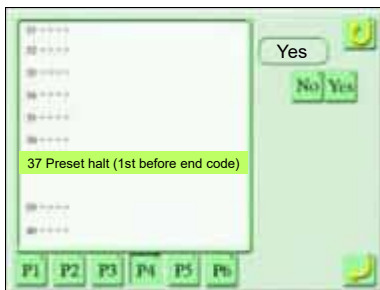

Setting range

Yes: Automatic stop is performed.

No: Automatic stop is not performed.

If "Yes" is selected, it is possible to perform frame back after stop of the machine.

Example: Yes

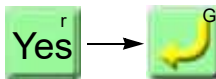

38 Table offset position

Register the table offset position.

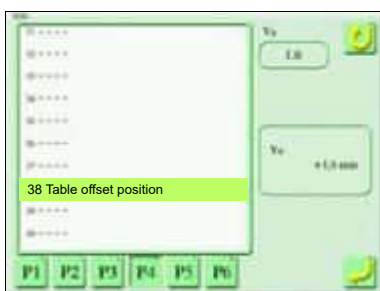

Setting range: Embroidery space

Example: Register the table offset position.

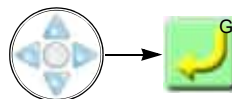

Frame travel

39 Arbitrary position

Register the desired frame position.

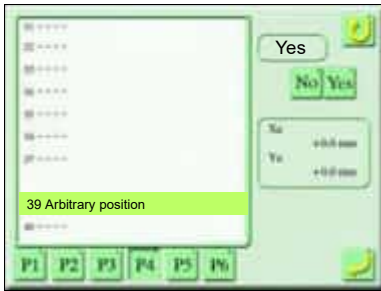

Setting range: Sewing space

Example: Register the frame position.

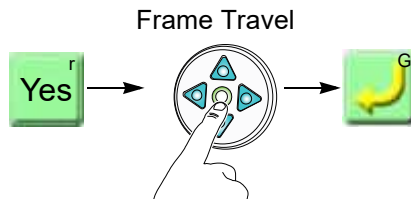

If "Yes" is selected, X/Y coordinates from frame origin will be displayed.

40 Needle Bar Color

Color the design on the operation panel according to the color of thread to use actually.



Setting range

Yes: The color is set to setting color when making design.

No: A color is selected in the palette.

Example: Change 8th needle to red.

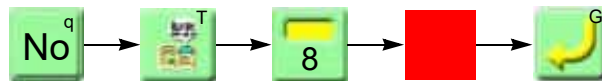

Select a color in the palette.



2-5. Page P5

[How to switch to page P5]

(1) Icon G



(2) P5

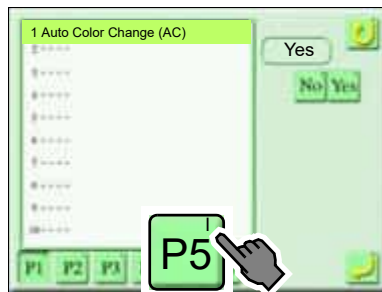

(3) Page P5

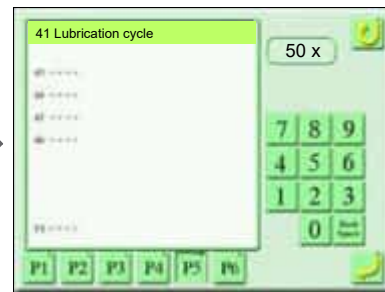

41 Lubrication cycle

Set the cycle (number of stitches) that Automatic lubrication system will lubricate to the rotary hook.

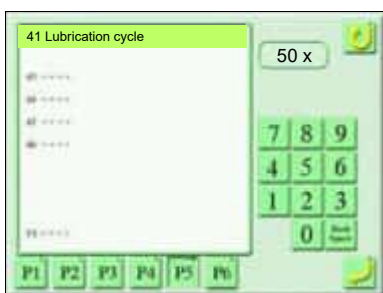

Setting range: 0 to 9,999,000 stitches

Example: Lubricate one time at 50,000 stitches.

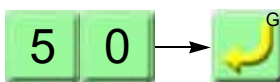

42 Lubrication cycle (head)

Set the cycle (number of stitches) that Automatic lubrication system will lubricate to the head.

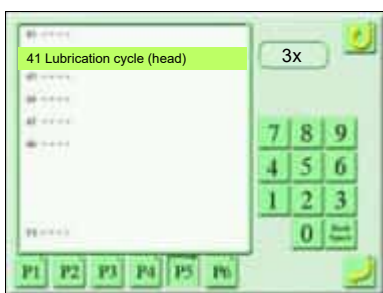

Setting range: 0 to 100

Example: Lubricate one time per 150,000 stitches.

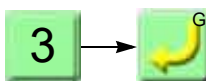

Input value here x the value set at "41 Lubrication cycle" is the lubrication cycle (head). For example, when you select "3" here, the lubrication cycle will be 150000 (3 x 50000). Recommended value is "3".

43 Sequin device (R)

Set sequin feed amount of Sequin Device at the right side.

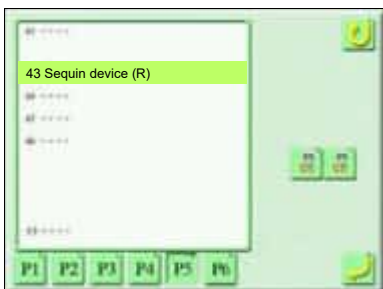

Setting range

Sequin Device III: 3.0 to 9.9 mm

Sequin Device IV: 3.0 to 23.0 mm

The left figure is an display example when the type of sequin is "SQ3". (→p.276)

Icon S will not be displayed in case of "SQ4".

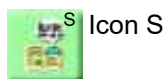

Example:

Set the sequin feed amount of Sequin 1 of the Sequin Device to 5.0 mm.

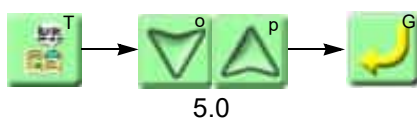

Icon T
Sequin 1

Icon S
Sequin 2

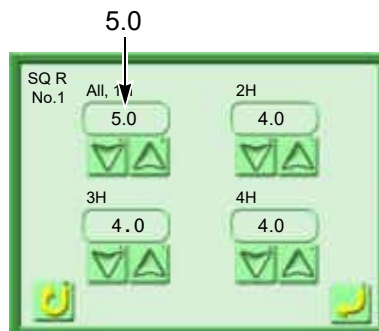

2H, 3H and 4H are not used currently.

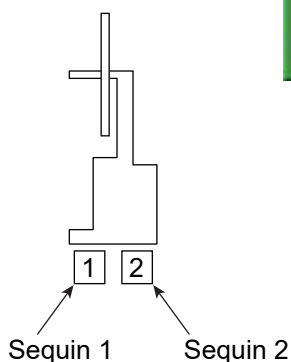

Rough standard of sequin feed amount is +1.0 mm for sequin size.

According to the feed amount, the maximum speed of the machine will become as below.

3.0 to 8.5 mm: 1,000 rpm

9.0 to 19.5 mm: Maximum speed will decrease at a uniform ratio.

20.0 to 23.0 mm: 600 rpm

44 Sequin device (L)

Set sequin feed amount of Sequin Device at the left side.

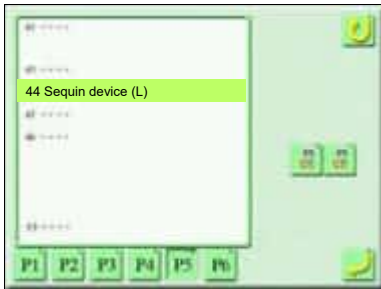

Setting range

Sequin Device III: 3.0 to 9.9 mm

Sequin Device IV: 3.0 to 23.0 mm

The left figure is an display example when the type of sequin is "SQ3".
(→p.276)

Icon S will not be displayed in case of "SQ4".

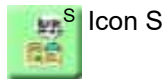

Example:

Set the sequin feed amount of Sequin 1 of the Sequin Device to 5.0 mm.

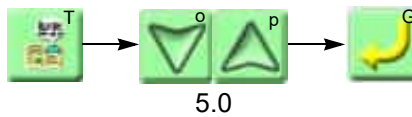

Icon T
 Sequin 1

Icon S
 Sequin 2

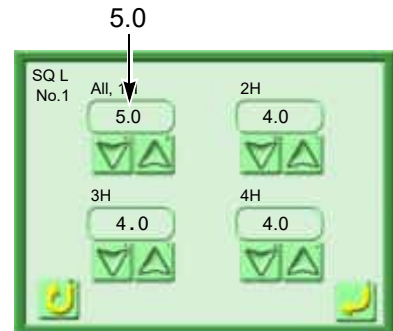

2H, 3H and 4H are not used currently.

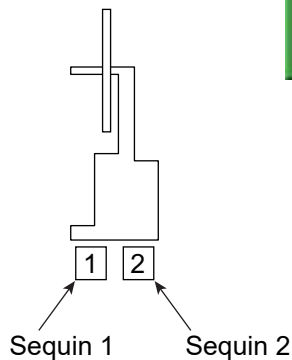

Rough standard of sequin feed amount is +1.0 mm for sequin size.

According to the feed amount, the maximum speed of the machine will become as below.

3.0 to 8.5 mm: 1,000 rpm

9.0 to 19.5 mm: Maximum speed will decrease at a uniform ratio.

20.0 to 23.0 mm: 600 rpm

45 Auto lifting - Sequin device

This function is applicable for Sequin device III only.

Set to raise/not to raise Sequin device at frame stepping, at thread breakage or when sequin chip runs out.

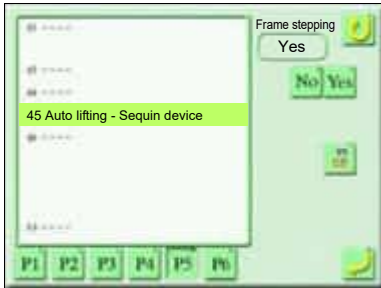

Setting range

Frame stepping

Yes: Move up Sequin device at frame stepping.

No: Do not move up Sequin device at frame stepping.

Thread breakage

Yes: Sequin device is raised at thread breakage.

No: Sequin device is not raised at thread breakage.

Running out of material

Yes: When sequin runs out, Sequin device is moved up.

No: When sequin runs out, Sequin device is not moved up.

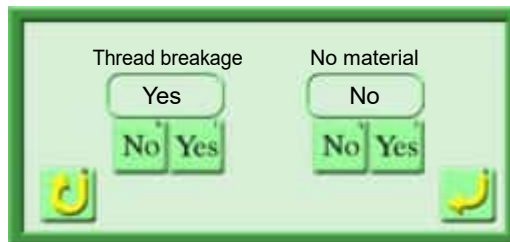

Example: Raise Sequin device at thread breakage.

At thread breakage

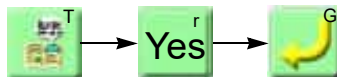

46 Boring step

Set Frame Movement at Boring step.

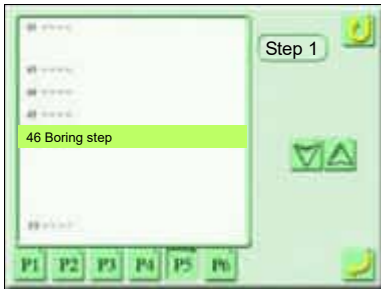

Setting range

Step 1: Data processing should not be performed. Do not perform Data Conversion at Step 1.

Step 2: Delete the frame travel data in the design data, and generate the frame travel data in the machine.

Step 3: Generate the frame travel data in the machine.

Without: Boring is not performed. When the setting of "4 Boring device" of page P7 is "No", select "Without".

Select Step 1 or Step 2 if there is a frame travel data (12 mm) in the design. Select Step 3 if there is not any frame travel data.

Example: Step 2

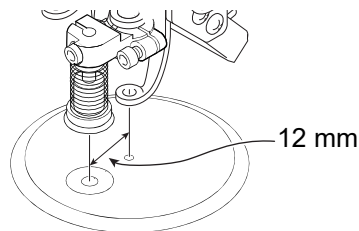
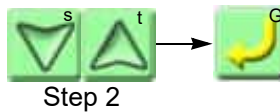

When switching to Boring step, the frame will moves 12 mm in vertical direction.

48 Multi Cord Setting

This is the setting that sews several stitches and stop the operation to treat the cord material after starting the operation at all needle bars equipped with Multi Cording Devices. The number of needles of return stitches are not counted.

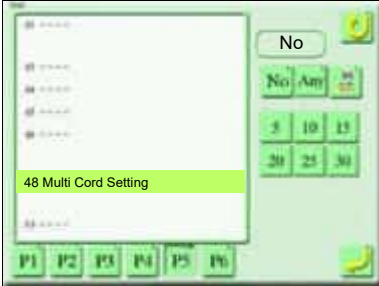

Setting range

No: Do not stop the operation.

Any: Stop the operation at all needle bars equipped with Multi Cording Devices.

Needle bar: Select the needle bar equipped with Multi Cording Devices and stop the operation.

Example:

Sew 10 stitches at 4th needle and stop the machine.

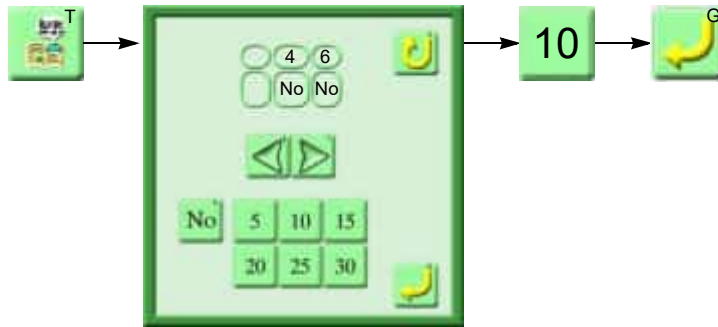

50 Detailed Network information

It is possible to check the setting state of Network.

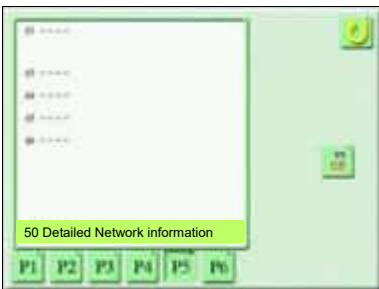

How to check

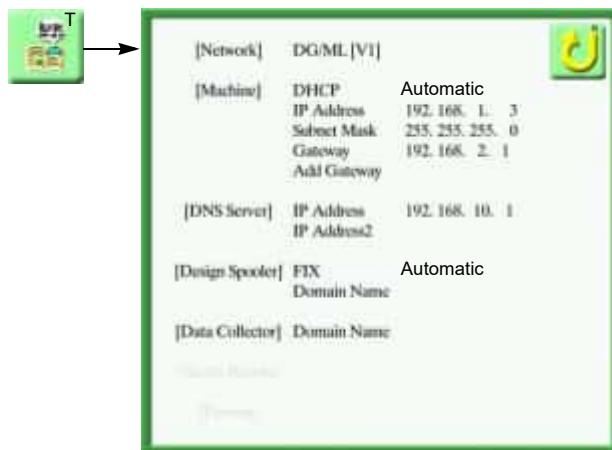

2-6. Page P6

[How to switch to page P6]

(1) Icon G



(2) P6

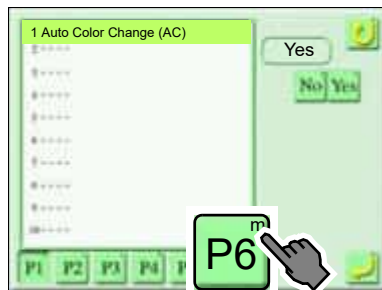

(3) Page P6



58 Detection of remaining Under thread (After Date Set, After ATH)

When Auto bobbin checker is equipped to the machine, set the confirmation timing of remaining under thread.



Setting range

After setting data: After setting data

After ATH: After ATH

Example:

Set the confirmation timing of remaining under thread to "After ATH".

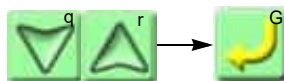

After ATH

When the bobbing changer is equipped to the machine, changing method of the under thread can be selected.

Automatic: After detecting that under thread becomes shorter than the setting amount, the bobbin changer will change the bobbin automatically.

Manual: Change the bobbin at the bobbin changer by manual operation.

2-7. Page P7

To change the parameter explained in page P7, it is necessary to input a password. For details, consult the distributor.

[How to switch to page P7]

(1) Icon G



(2) Press P6 twice.

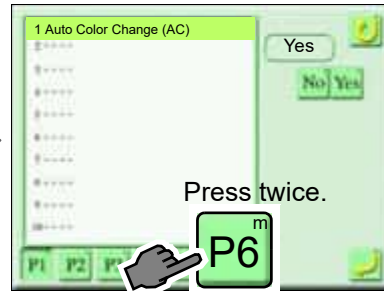

(3) Icon S

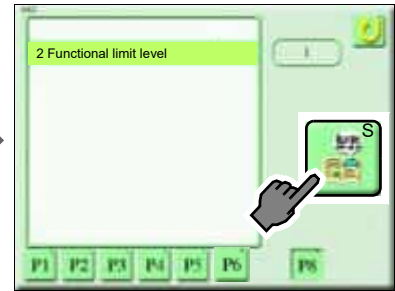

(4) Input a password.



(5) To set



(6) SEL

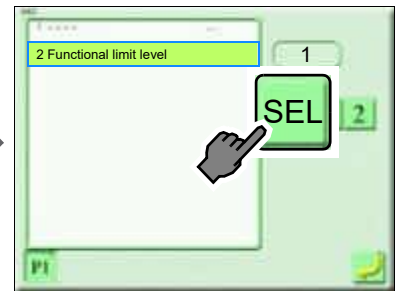

(7) Icon T

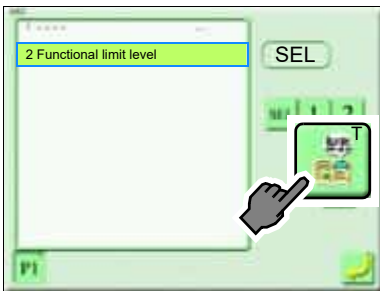

(8) ALL Yes

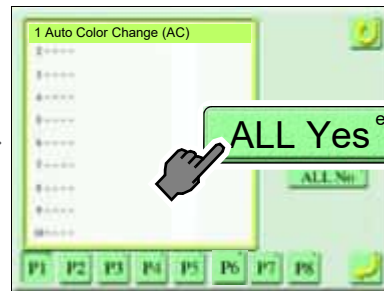

Outer frame turns yellow during setting level SEL.

Yellow

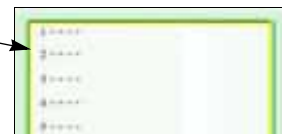

(9) To set

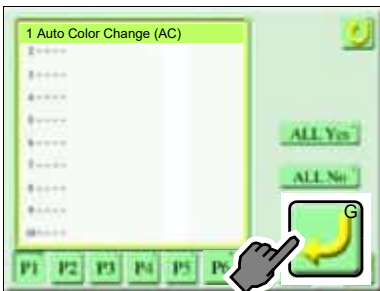

(10) To set

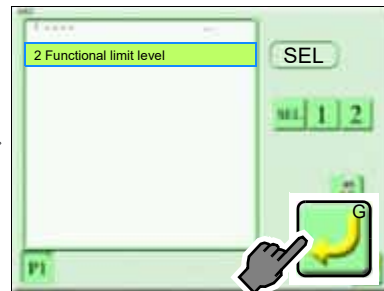

(11) Icon A (Completed)

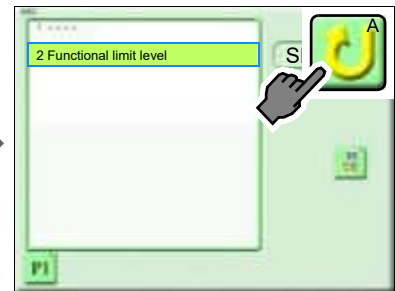

(12)P7

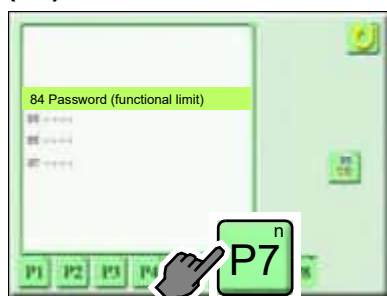

(13)Page P7 (Completed)



[71 R.P.M. setting]

2Low speed r.p.m. / Low speed code r.p.m. (Input of a password is necessary)

Set the most decreased sewing speed (Low speed r.p.m.) and sewing speed at low speed code section (Low speed code r.p.m.).

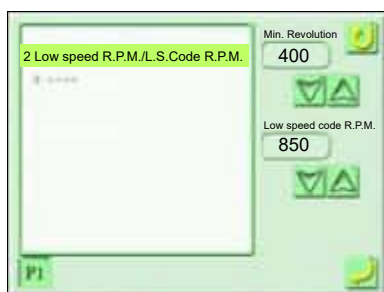

Setting range

Low speed R.P.M.: 250 to 600 rpm

Low speed code R.P.M.: 250 to Maximum r.p.m. of machine

Example: Set Low speed r.p.m. to 450 rpm.

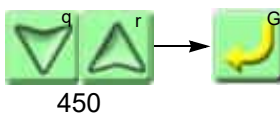

3 Start/ATH inching r.p.m. (Input of a password is necessary)

Start inching

After stopping the machine in the middle of sewing, set sewing speed at slow operation performed when the operation starts again.

ATH Inchings

Set sewing speed by slow operation performed when starting operation after data set and thread trimming.

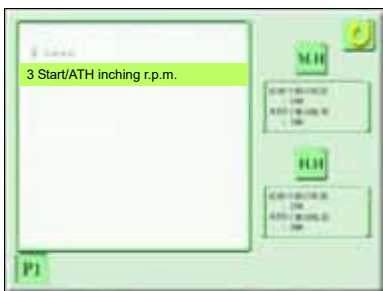

Setting range

M.H (Embroidery mode), H.H (Sewing mode)

Start inching: 100, 150, 200, 250 rpm

ATH Inchings: 100, 150, 200 rpm

Example: Set Start inching R.P.M. to "200" in sewing mode.

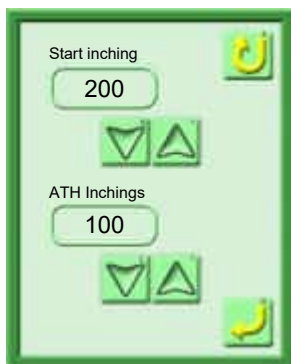
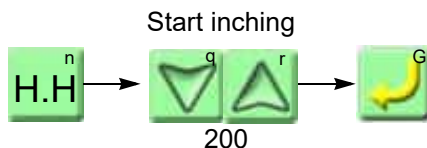

[72 Stitch Compensation]

1 Backlash (X) (Input of a password is necessary)

Correct driving error of the frame generated when a stitch turns back in horizontal direction.

When the setting of Backlash has been changed by "Step unit setting" individually, the value of "Step unit setting" will take the priority.

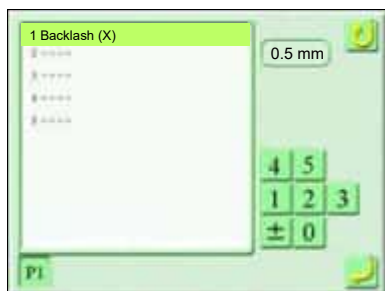

Setting range: -0.5 to +0.5 mm

Example: Execute correction by 0.5 mm.

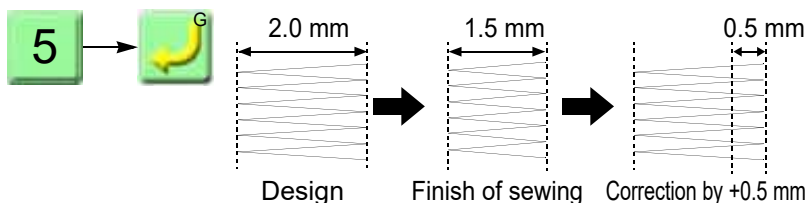

If the value is input, the setting of Satin stitch will be invalid.

2 Backlash (Y) (Input of a password is necessary)

Correct driving error of the frame generated when a stitch turns back in vertical direction.

When the setting of Backlash has been changed by "Step unit setting" individually, the value of "Step unit setting" will take the priority.

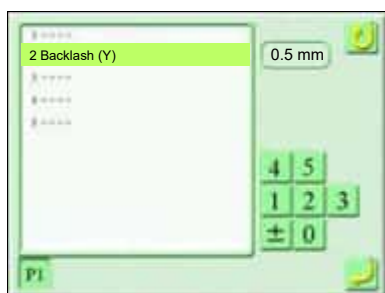

Setting range: -0.5 to +0.5 mm

Example: Execute correction by 0.5 mm.

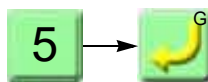

If the value is input, the setting of Satin stitch will be invalid.

3 Satin Stitch (area) (Input of a password is necessary)

Set a target range of Satin Stitch (Expansion).

When the setting of Satin stitch (area) has been changed by "Step unit setting" individually, the value of "Step unit setting" will take the priority.

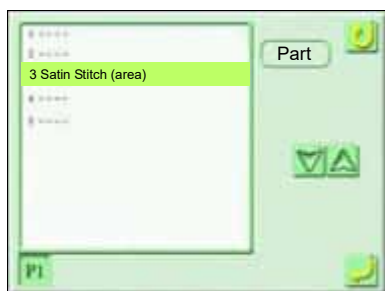

Setting range

Whole: All Satin stitches in design

Part: Function code "Satin stitch" section

No: It is not added.

Example: Part

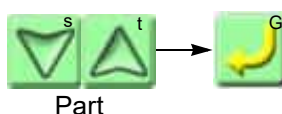

Part

4 Satin Stitch (density) (Input of a password is necessary)

Set stitch length (a in the figure below) that is regarded as Satin stitch. Stitches of the setting value or less will be regarded as Satin stitch.

When the setting of Satin stitch (density) has been changed by "Step unit setting" individually, the value of "Step unit setting" will take the priority.

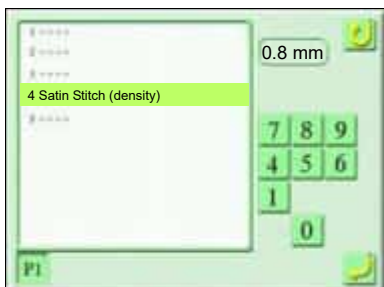

Setting range: 0.4 to 1.0 mm

Example: Regard the stitch of 0.8 mm or less as Satin stitch.



It is effective when "3. Satin Stitch (Area)" is set to "Whole" or "Part".

5 Satin Stitch (Expansion) (Input of a password is necessary)

This setting sets up an adding amount to a stitch that was judged as Satin stitch in above 4 Satin stitch (density). 1/2 (b) of the set value will be added to both sides of the stitch (c) respectively.

When the setting of Satin Stitch (Expansion) has been changed by "Step unit setting" individually, the value of "Step unit setting" will take the priority.

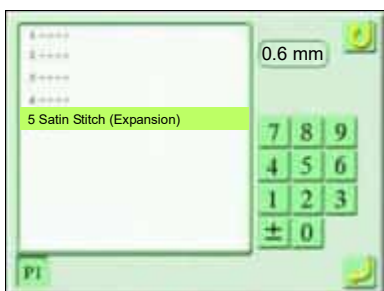

Setting range: -1.0 to +1.0 mm

Example: Add 0.6 mm.



In this example, b is 0.3 mm.

[73 Design Setting]

2 Condition data (Input of a password is necessary)

When you register the design saved in the USB memory into the machine memory, set whether the Condition Data (Color change sequence, Start position, Presser Foot Setting) are registered together with the design into the machine memory or not.(→p.50)

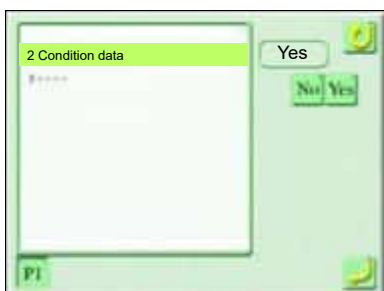

Setting range

Yes: It will be registered into the machine memory.

No: It will not be registered into the machine memory.

Example: Yes



3 Automatic design rotation (180 deg.) (Input of a password is necessary)

This is the setting to rotate a design by 180° automatically at data set.

Other designs in the machine memory are not affected. This function rotates a design not in each design like "Data Conversion" but in each type of frame.

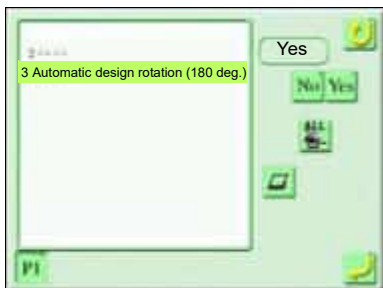

Setting range

To rotate the design by 180°, select the following icons.



Tubular goods frame, Border frame, Cap frame



Border frame

Yes: Rotate the design by 180°.

No: A design is not rotated.

Example: Rotate the design by 180°.



[74 Frame Setting]

3 Frame weight (Input of a password is necessary)

Set the frame added weight (total weight of gauge frames and fabric for one machine).

If the frame weight becomes heavy, the stitch length of X-axis and Y-axis directions may become large. If the stitch length becomes large, perform adjustment.

Even if the value exceeding number of head x 4 kg is set, the frame movement will not change.

Stitch length accuracy is just rough standard since it is affected by friction.

Stitch length (against r.p.m.) and Maximum r.p.m. may be limited automatically depending on this value.

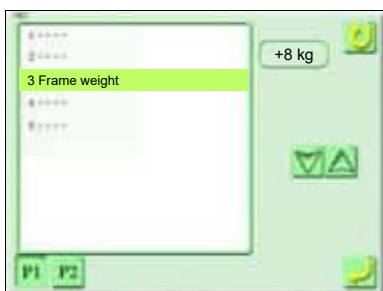

Setting range

0 to +99 kg

Example: +8

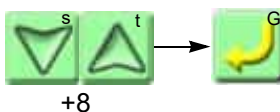

4 Frame Travel Speed, Frame Stepping Method (Input of a password is necessary)

Set the frame travel speed and the frame stepping method at frame stepping.

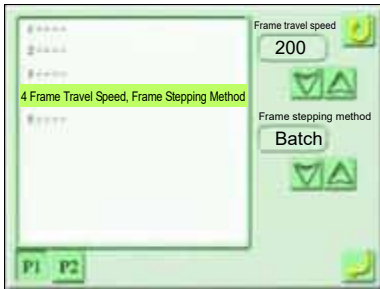

Setting range

Frame Travel Speed: 100, 200, 400 mm/second

Frame stepping method: Batch, 1 stitch

Batch: Perform frame travel directly to frame stepping point.

By 1 stitch: Perform frame travel stitch by stitch as design data.

Example: Set Frame travel speed to "200".

Frame travel speed

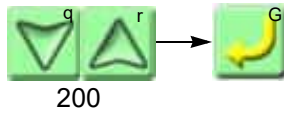

5 Frame start timing (Input of a password is necessary)

! CAUTION

! When changing the value, consult the distributor. Some operating condition could cause occurrence of bad effect in embroidering.

Set the main shaft angle where the frame starts moving.

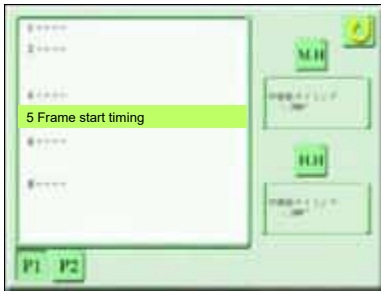

Setting range

M.H (Embroidery mode), H.H (Sewing mode)

280 to 310: Frame start timing (°)

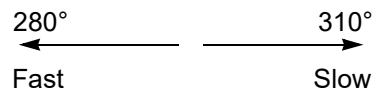

[Thread tension]
Weak

[Thread tension]
Strong

[Stitch length]
Narrow

Example: Set Frame start timing to 285° in sewing mode.

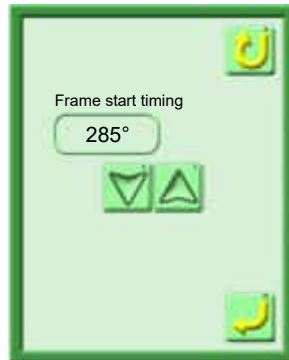
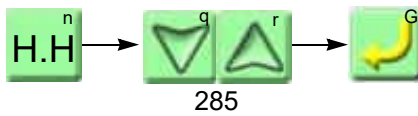

6 Absolute origin search at power ON

Set whether or not Absolute origin search is performed when the power is turned ON.

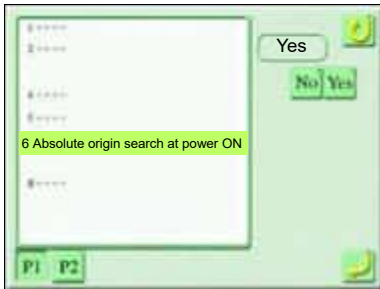

Setting range

Yes: Execute absolute origin search.

No: Absolute Origin Search is not executed.

Example: Yes

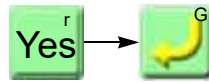

8 Frame Travel Direction

Set which direction to move the frame when pressing the frame travel key.

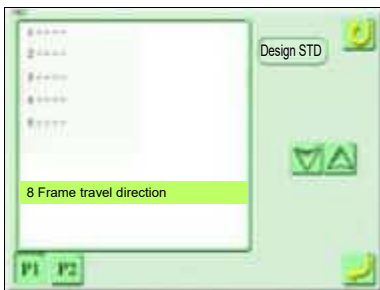

Setting range

Frame Standard: The frame will move to the direction which is the same as that of the frame travel key.

Design standard: The frame will move to the direction which is opposite to that of the frame travel key.

Example: Design standard



Design standard

11 Origin correction amount (X)

Frame origin of X-axis direction will be fine-adjusted.

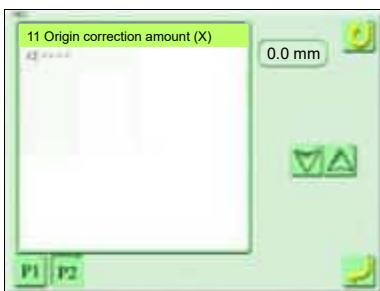

Setting range

-2.0 to +2.0 mm

Example: Correction of 0.5 mm is performed.

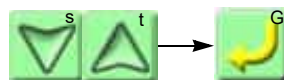

0.5

12 Origin correction amount (Y)

Frame origin of Y-axis direction will be fine-adjusted.

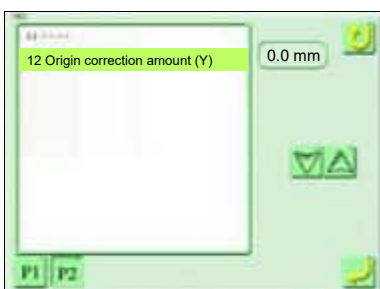

Setting range

-2.0 to +2.0 mm

Example: Correction of 0.5 mm is performed.

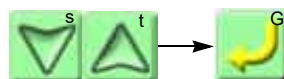

0.5

[75 ATH Setting]

1 ATH (Input of a password is necessary)

This is the setting to trim the thread automatically at Color change, Frame stepping and Offset frame travel.



Setting range

Yes: ATH is performed.

No: ATH is not performed.

Example: Yes

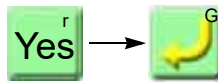

3 Sensitivity of ATH error detection (Input of a password is necessary)

Set the sensitivity of ATH error detection after thread trimming.

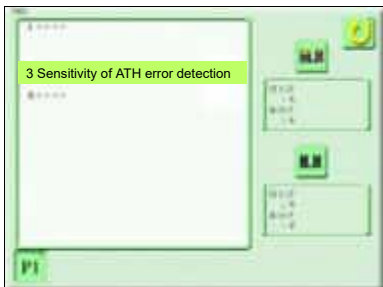

Setting range

M.H (Embroidery mode), H.H (Sewing mode)

Skip stitches (It will not be detected by cam type ATH.)

0: Do not detect.

1 to 50: Detect.

Select the value of 1 to 50.

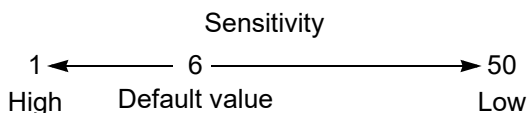

This is the detection sensitivity to make the machine judges that the thread is not broken due to skip stitches at thread trimming.

The machine will stop at the detection, and the code No.3AC will be displayed.

Thread separation

0: Do not detect.

1 to 50: Detect.

Select the value of 6 or more.

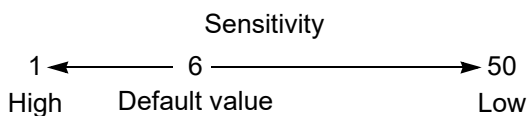

This is the detection sensitivity to make the machine judges that the thread is not broken due to thread separation of the movable knife at thread trimming. The machine will stop at the detection, and the code No.3AB will be displayed.

Example: Set "Skip stitches" to "10".

Skip stitches

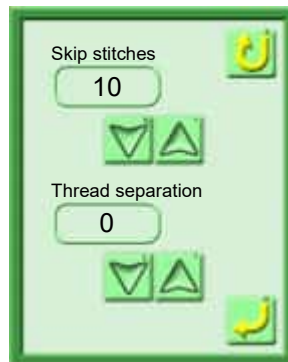
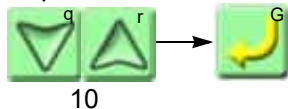

4 Under thread Release

This is the setting to release the under thread forcibly to decrease the thread tangle at start of sewing.



Setting range:

Yes: The under thread will be released.

No: The under thread will not be released.

Example: Yes



[76 Stop position]

1 Stop at Lower Dead Point (Input of a password is necessary)

This is the setting to stop (Stop at lower dead point) the machine at sewing end with the needle stuck.

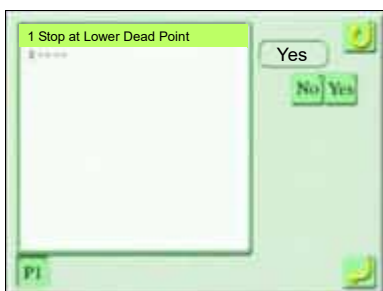

Setting range

Yes: Stop at Lower Dead Point is performed.

No: Stop at Lower Dead Point is not performed.

Example: Yes

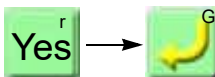

2 Return Frame at Lower dead point (Input of a password is necessary)

This is the setting to return the frame by manual offset even after frame travel during Stop at Lower Dead Point.

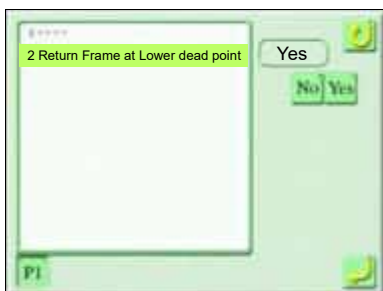

Setting range

Yes: The frame is returned by manual offset.

No : The frame will be returned by manual offset. However, the frame will not be returned by the amount of moving frame during stop at the lower dead point.

Example: Yes

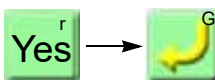

[77 Optional Device (Hardware)]

1 Sequin device (R) (Input of a password is necessary)

Set whether Sequin device (R) will be equipped or not and the type of device.

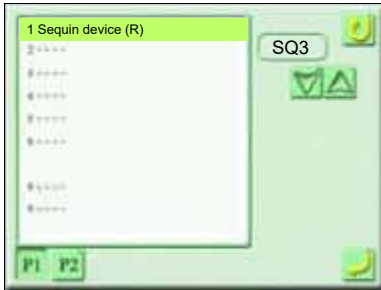

Setting range

SQ3: Sequin device III

SQ4: Sequin device IV

Without: Without sequin device

Example: SQ3

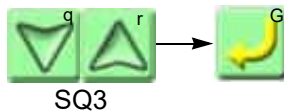

2 Sequin device (L) (Input of a password is necessary)

Set whether Sequin device (L) will be equipped or not and the type of the device.

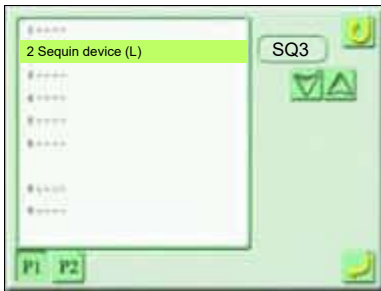

Setting range

SQ3: Sequin device III

SQ4: Sequin device IV

Without: Without sequin device

Example: SQ3

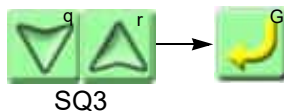

3 Insertion of jump at sequin (Input of a password is necessary)

This is the setting to insert one stitch of non-data jump code just before or after sequin feed.

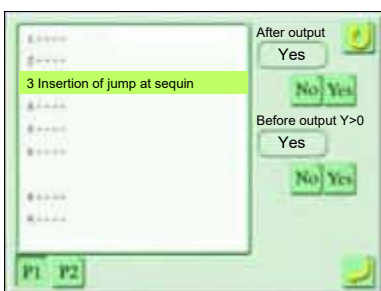

Setting range

After output

Yes: Non-data jump code is inserted just after sequin feed.

No: Non-data jump code is not inserted.

Before output Y>0

Yes: Non-data jump code is inserted just before sequin feed.

No: Non-data jump code is not inserted.

Example: After output, Yes

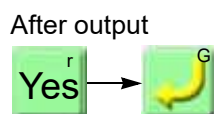

4 Boring device (Input of a password is necessary)

Set to equip/not to equip Boring device.

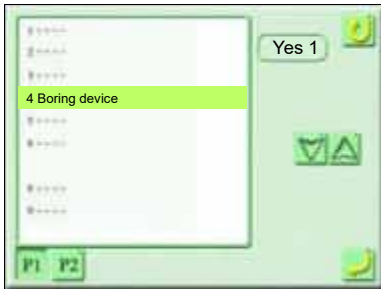

Setting range

Yes 1: Device is equipped to 1st needle.

Yes 2: Device is equipped to 2nd needle.

Yes 15: Device is equipped to 15th needle.

Example: Yes 2

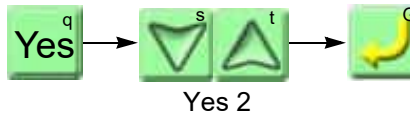

5 Cording Device (Input of a password is necessary)

Set to equip/not to equip Cording device (KB-2M).



Setting range

L: Equipped to the left side.

R: The device is equipped to the right side.

LR: Equipped to right and left.

No: Cording device is not equipped.

Example: L

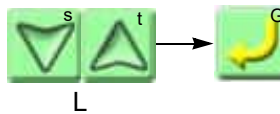

6 Multi Cord Device (Input of a password is necessary)

Set to equip/not to equip Multi Cording Device.

Six pieces can be mounted on one head at most. No. of attachable needle bar differs depending on model.

Machine Type	No. of attachable needle bar
9-needle machine	2 to 7
12-needle machine	4 to 9
15-needle machine	5 to 10

Depending on cord material to use, there is a tendency that setting "Presser foot timing" to the below values will make sewing stable.(→p.241)

Material having strong twist: +20

Material having weak twist: -10

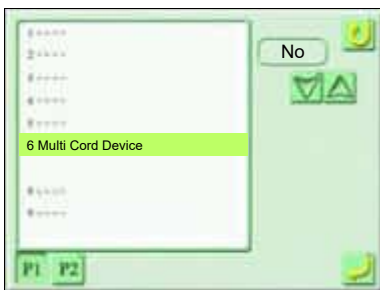

Setting range

Yes: To equip

No: Cording device is not equipped.

Example: Equip to 6th and 7th needles.

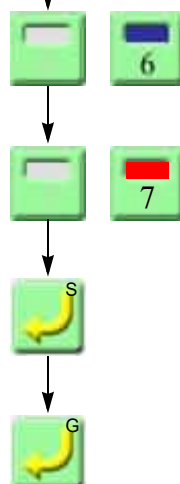
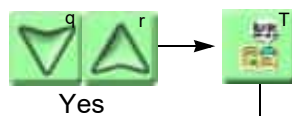

The color which has been set at "Needle Bar Color" will appear. (→p.218)

8 Air Pressure Sensor (Input of a password is necessary)

Set to equip/not to equip an air compressor.

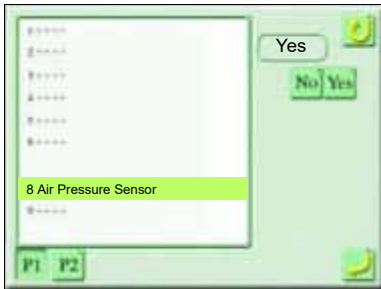

Setting range

Yes: Air compressor is equipped.

No: Air compressor is not equipped.

In this function, when option that needs air compressor is equipped, select "Yes". (Example: Sequin device IV, etc.)

Example: Yes

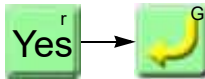

9 Auto lubrication system (Input of a password is necessary)

Set whether Automatic lubrication system will be equipped or not and the type of the device.

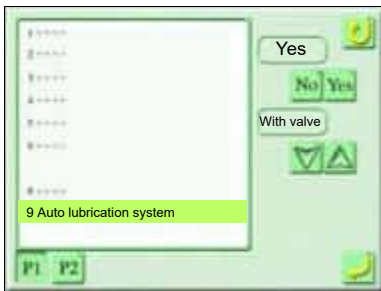

Setting range

Yes: Automatic lubrication system is equipped.

If "Yes" is selected, select the type of the device.

With valve

Without valve

No: Automatic lubrication system is not equipped.

Example: Yes, without valve

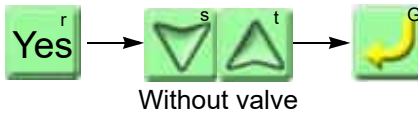

11 Bobbin changer (Input of a password is necessary)

Perform setting as with/without the bobbin changer.

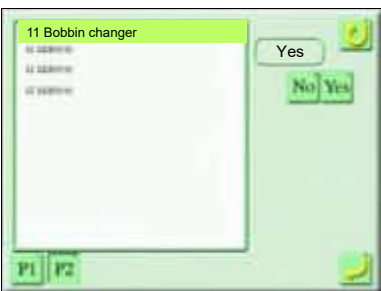

Setting range

Yes: With the device

No: Without the device

Example: Yes



12 LED Light (Input of a password is necessary)

Perform setting as with/without LED light.



Setting range

Yes: With the device

No: Without the device

Example: With LED light

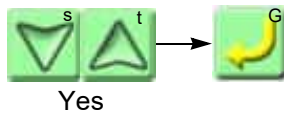

14 Sequential Control Device (Input of a password is necessary)

Set to "With/without Sequential Control Device".

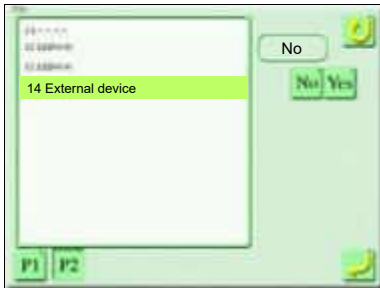

Setting range

Yes: With the device

No: Without the device

Example: Yes

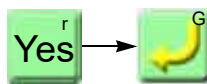

16 Bar cord reader (Input of a password is necessary)

Perform setting as with/without Bar cord reader.

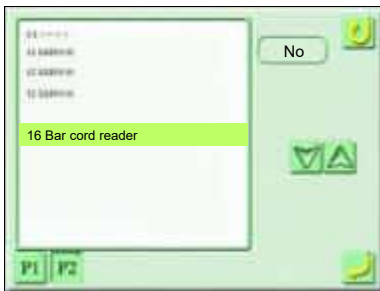

Setting range

No: Without the device

Fixing type: With the device (Fixing type)

Example: Fixing type

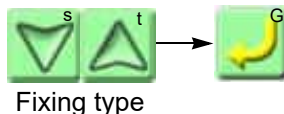

[78 Optional device (Software)]

1 Network (Input of a password is necessary)

Set whether network connection with DG/ML by Pulse or Sidekick is performed or not and IP address, etc.



Setting range

[Page P1]

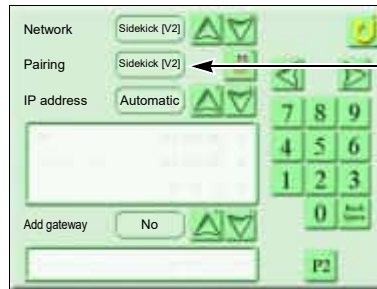

Pairing is displayed only in case of Sidekick [V2].^[*1]

*1 This machine and Sidekick terminal are being connected one to one.

Network

DG/ML [V1]: Connect with DG/ML by Pulse.

Sidekick [V2]: Connect to Sidekick directly.

The design is not registered in the machine memory.

No: Network is not connected.

Pairing

When pairing is canceled.



IP address

Auto: IP address will be obtained from DHCP server.

Manual: Obtain following items manually without using DHCP server.

- IP address
- Subnet mask
- Gateway

Add gateway

Yes: Add gateway.

No: Gateway is not added.

[Page P2]



DNS

Yes[1]: IP address of DNS1 server

Yes[2]: IP address of DNS2 server

No: Without the device

FIX

Auto: IP address at a host personal computer side will be searched automatically.

Manual: Set IP address of the host PC manually.

Example: Perform Network connection under the following condition.

Network: Sidekick [V2]

IP address: Automatic

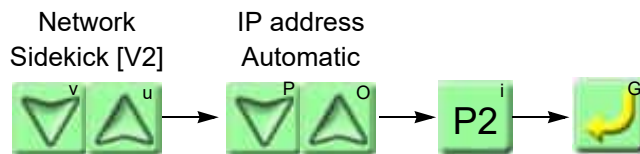

2 Network name (Input of a password is necessary)

Set Network name.

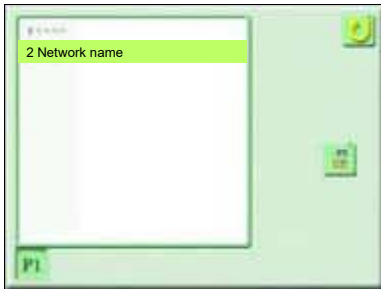

Example: Set Network name to "TAJIMA_NET".



Input Network name.

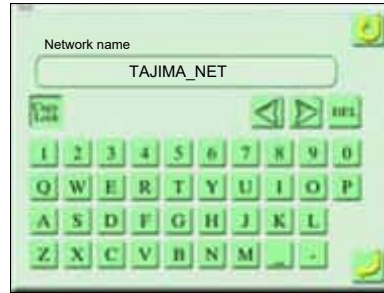

[79 Sequence control]

1. 5 V external input (Input of a password is necessary)

Connect the external device to 5 V external input terminal and assign the machine function to that connected terminal. As a result, it is possible to control (assigned function) the machine by the control signal (5 V DC voltage) from outside the machine.

For details, consult the distributor.

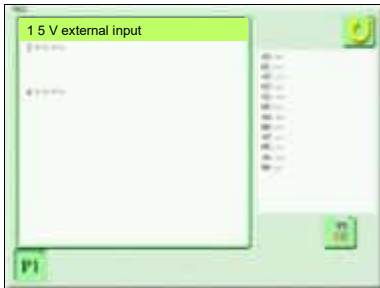

2. 5 V external output (Input of a password is necessary)

Connect the external device to 5 V external output terminal and assign the machine function to that connected terminal. As a result, it is possible to control (assigned function) the external device by the control signal (5 V DC voltage) from outside the machine.

For details, consult the distributor.

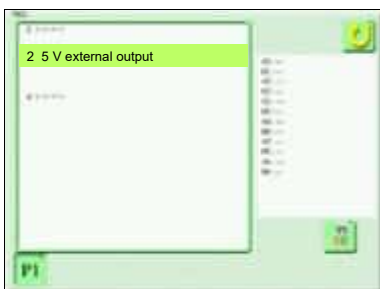

4. 24 V external output (Input of a password is necessary)

Connect the external device to 24 V external output terminal and assign the machine function to that connected terminal. As a result, it is possible to control (assigned function) the external device by the control signal (24 V DC voltage) from outside the machine.

For details, consult the distributor.

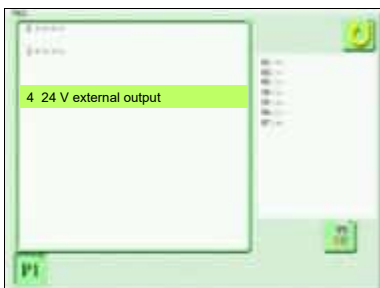

2-8. Page P8

Page P8 shows the operation that has the purpose to perform the maintenance of the machine by the service personnel of your distributor. To change the parameter, it is necessary to input a password.

For details, consult the distributor.

[How to switch to page P8]

(1) Icon G



(2) Press P6 twice.

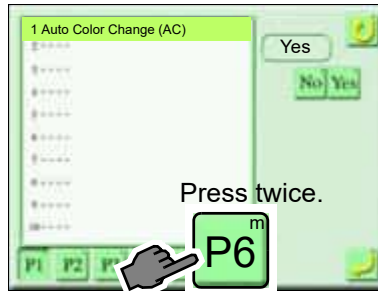

(3) Icon S

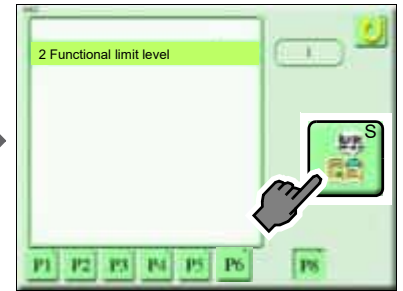

(4) Input a password.



(5) To set



(6) SEL

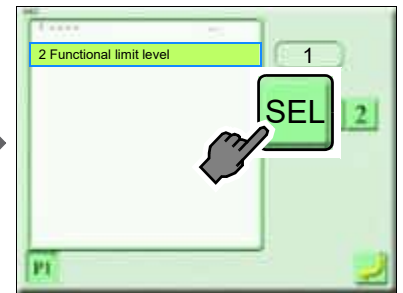

(7) Icon T

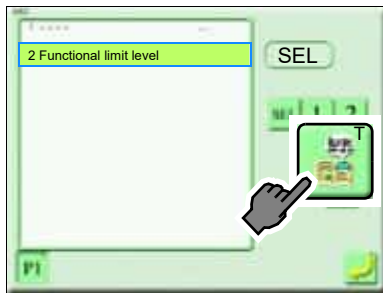

(8) ALL Yes

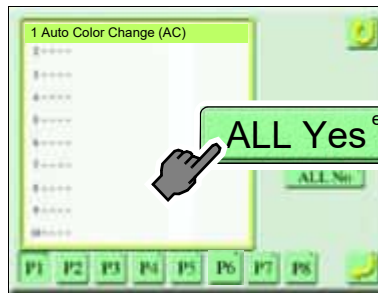

Outer frame turns yellow during setting level SEL.



(9) To set

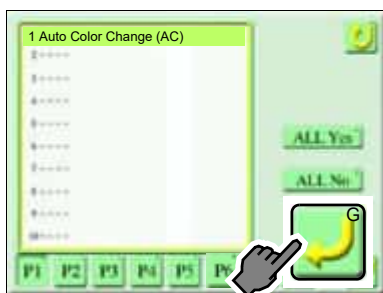

(10) To set

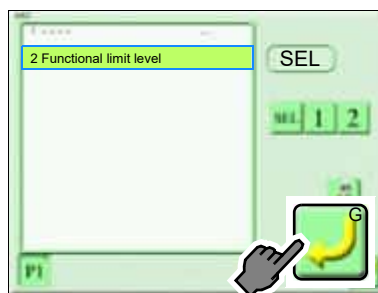

(11) Icon A (Completed)

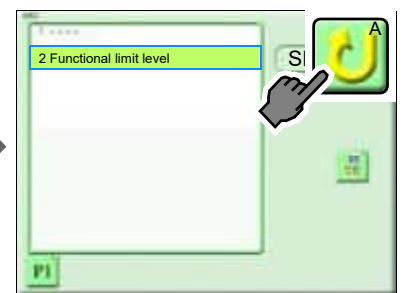

(12)Page P8 (Completed)

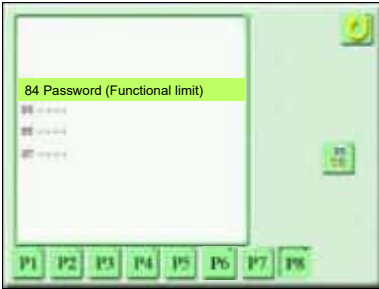

[84 Password (Functional limit)]

1 Password (Functional Limit) (Input of a password is necessary)

Change the password. Select the password from 4 to 8 digits alphanumeric characters.

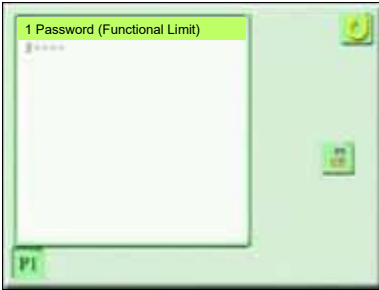

Example: Set password.



Input the password (example: 57HJ) after change.

Input the password again after change.

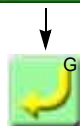

For details of the password, consult the distributor.



2 Functional Limit Level

Change the functional limit level.

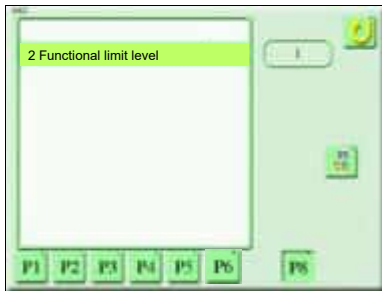

Example: Change Functional Limit Level from "1" to "2".



Input the password (example: 57HJ) after change.



For details of the password, consult the distributor.

[85 Machine adjustment]

1 Date and time (Input of a password is necessary)

Set date and time.

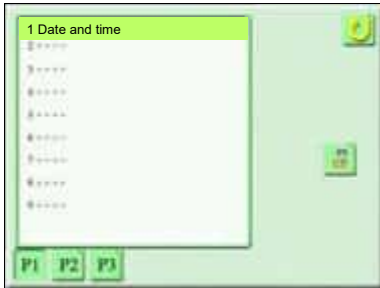

Setting range: Year, month, date, time, second

Example: Set date and time to February 10th.

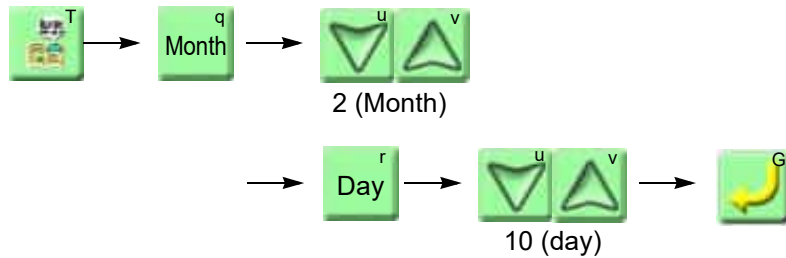

2 Total number of thread breakage (Input of a password is necessary)

Display the number of thread breakage of upper thread/under thread by head unit.

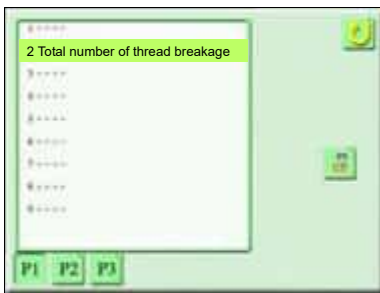

Example: Display Total number of thread breakage.

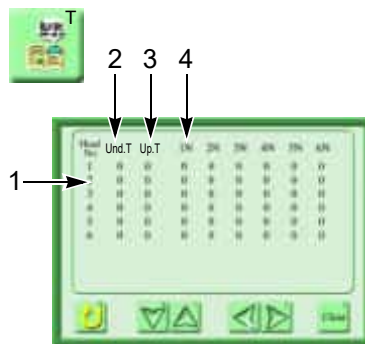

1. Head No.
2. Number of under thread breakage
3. Number of upper thread breakage
4. Number of upper thread breakage in needle bar unit

3 Error stack (Input of a password is necessary)

Display errors that have ever occurred and time of occurrence on the operation panel.

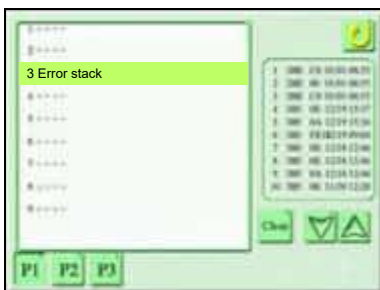

The error occurred last will be No.1

4 Memory process (Input of a password is necessary)

Perform processing of the data in the machine memory. (Parameter setting value, and Error stack)

CAUTION

If "Memory initialize" is executed, the design data, general setting data and the set amount of "86 Machine Condition" will be deleted.

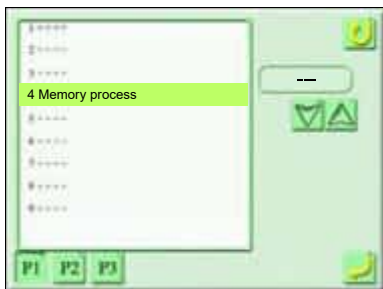

Setting range

Backup

Setting data recorded in the machine memory^[1] will be written into USB memory. Set USB memory that become the folder to save setting data into the operation panel before the operation, and select icon B.



Parameter initialize

Return the setting data [1] to the value at shipment from the factory. However, the value of "86 Machine condition" will not be changed.

Memory initialize

The setting value of the design data, general setting data, and "86 Machine condition" will be deleted. When setting again after this operation, refer to "Parameter setting chart" attached to the machine at shipment.^[2]

[1] Parameter setting value, Error stack

[2] R.P.M., Total stitch count, Display of finishing embroidery, Frame back
Frame forward

Writing

Setting data saved in USB memory will be written into the machine memory by the operation of "Backup". Set USB memory, in which the setting data is saved, to the operation panel before the operation, and select icon B. It is possible to check repeatability with writing the setting data of the machine, which had trouble, to another machine by this function. A software version of the machine which performs "Writing" needs to be the same as that of the machine which performed "Backup".

Example: Backup

1. Set the USB memory.
2. Select the backup.

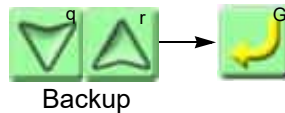

5 Machine log data download (Input of a password is necessary)

Get the operation logs and the communication records. This function is for analyzing cause of some trouble of the machine. When your distributor asks to get log datas, send datas to your distributor saving log data information in the USB memory by the following operation.

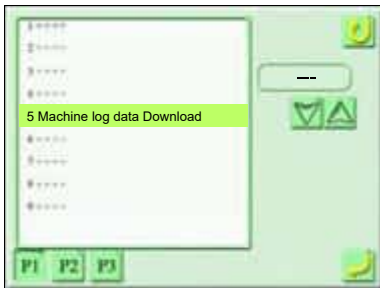

Setting range

Save on operation panel

Save the log datas into a CF (Compact Flash Memory) inside of the operation panel for 50 times. The log datas exceeding 50 times will be overwritten.

It is not possible to take out any data from a CF.

Save in USB.

Save log datas saved in the CF and log datas acquired at this time into the USB memory.

Example: Save in USB.

To set USB
memory

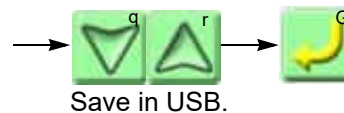

6 Display of main shaft stop position (Input of a password is necessary)

It displays whether the current main shaft angle is within the range of fixed position or not.

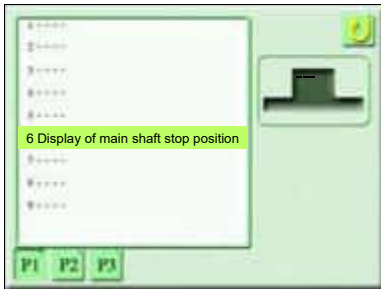

Within fixed position



Out of fixed position, or Stop at Lower Dead

7 Display of needle position angle (Input of a password is necessary)

Display the value of the color change potentiometer and set the ball-screw type color change system.

CAUTION

If icon q or r is selected, color change will be performed. Do not put your hands etc. near the needle bar case. You could be injured.

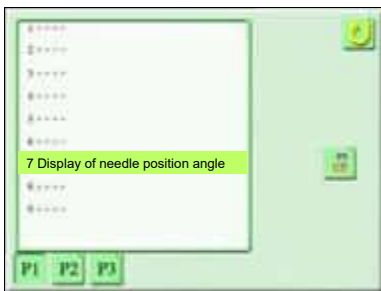

Example: Display the value of color change potentiometer.

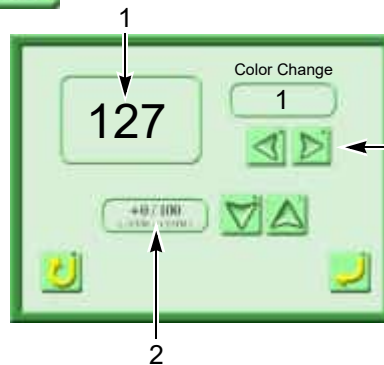

1. Value of potentiometer of needle bar selected currently
It is normal when the value at the first needle is "127".
2. Correcting value of color change position
After Memory initialize, set the value of "Correction of Color" mentioned on the label stuck on the operation panel stand.

8 Time for detect power failure (Input of a password is necessary)

Set the machine movement when the power is shut off momentarily.

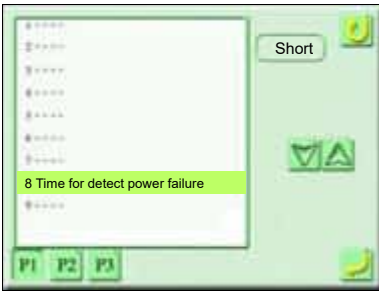

Setting range

Short

When the power is shut off momentarily, the machine will stop at the fixed position.

Long

It is possible to sew without stopping the machine even if the power is shut off momentarily in longer time than "Short". However, when the power is shut off during some period of time, the machine will stop. In this case, the design in the middle of sewing cannot be guaranteed.

Example: Short

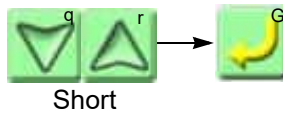

9 Main Shaft Brake (Input of a password is necessary)

This is the setting to apply/not to apply the brake of Main shaft motor at stop of the machine.



Setting range

Yes: Apply the brake. (Fixing main shaft)

No: Do not apply the brake. (Release of fixing main shaft)

If "No" is selected, it is possible to turn the main shaft by hand with the power ON.

Example: No

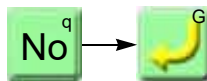

12 Manual frame travel speed (Input of a password is necessary)

Perform fine tuning of Frame travel speed when Manual frame travel is performed.

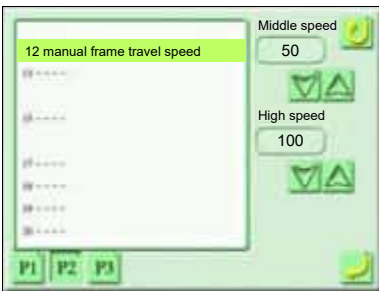

Setting range

Middle speed: 30 to 70 mm/second

High speed: 80 to 150 mm/second

Example: Set Middle speed to "60".

Middle speed

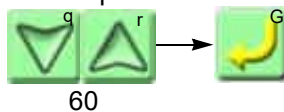

13 Automatic frame travel speed (Input of a password is necessary)

Perform fine adjustment of frame travel speed at offset frame travel.

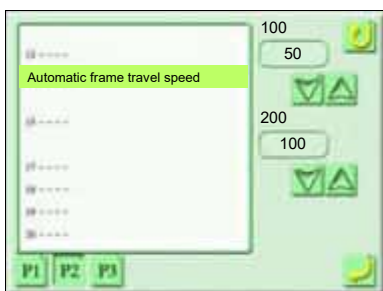

Setting range

100: 80 to 150 mm/second

200: 180 to 220 mm/second

400: 350 to 450 mm/second

The value here will be reflected in "4 Frame Travel Speed" of page P7.

Example: Set "100" to "120".

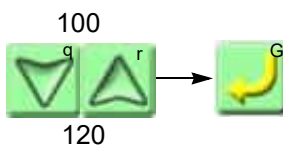

15 Software install (Input of a password is necessary)

Upgrade the version of the software.



Refer to the detail page.(→p.323)

17 Sequin Chip Feed (Input of a password is necessary)

This is the setting to feed sequin chips one by one with the tension base switch. It is possible to operate only when the needle bar equipped with Sequin device is selected.



Example: Feed out sequin ship of 3rd head.

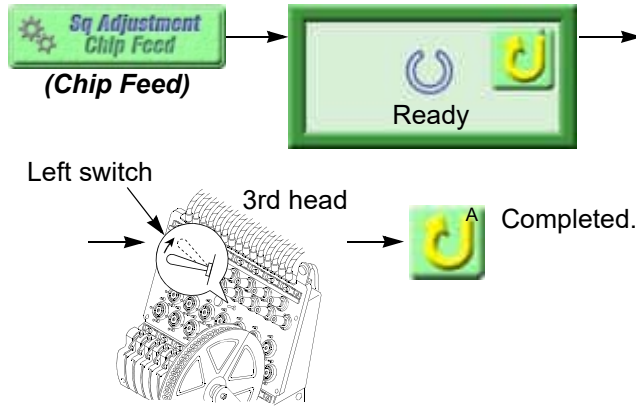

Raise the tension base switch (left switch). Sequin chips will be feed out.

Main shaft angle

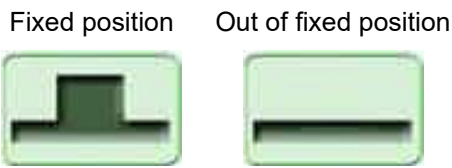

17 Presser foot installation for Sequin (Sequin Chip Feed) (Input of a password is necessary)

This is the operation to move down the needle bar and attach the presser foot or adjust the height of the presser foot for Sequin Device.

CAUTION

If Yes is selected, a needle bar will be moved down. Therefore, do not put your hands etc. near the needle bar case. You could be injured.

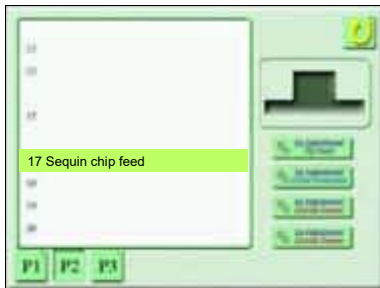

Example: Adjust the presser foot position of Sequin Device.

(Presser Foot)

OK to move the needle bar to lower dead position?

No Yes

Yes

Pressing Yes will move down the presser foot and the needle bar.

Loosen the screw 1 to adjust the position of the presser foot base so that clearance between the needle clamp and the presser foot base (in the figure below) becomes 0.5 mm.

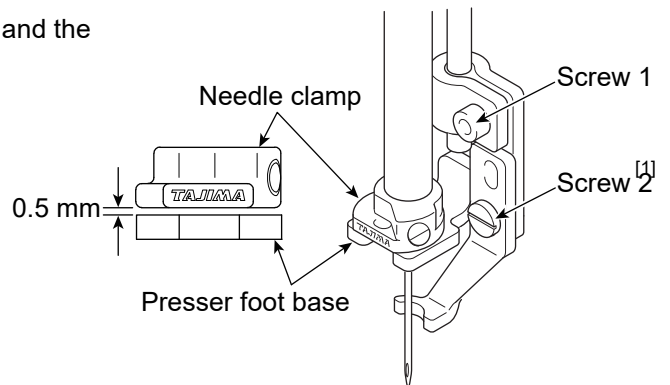

[1] Use the screw 2 when adjusting the height of the presser foot for Sequin according to thickness of the fabric.

Ready

A Completed.

Pressing icon A will move up the needle bar and the presser foot.

18 Presser foot lower dead point adjustment (Input of a password is necessary)

Adjust the presser foot lower dead point. Adjust the presser foot lower dead point not by inputting the value but by touching the presser foot to the fabric visually. The value set here will be reflected to all heads.



Example: Adjust Presser foot lower dead point to the thickness of the fabric visually.

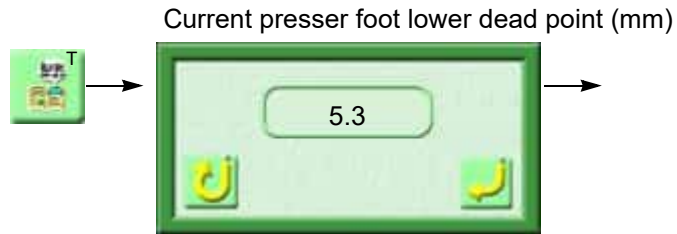

Example: 3rd head

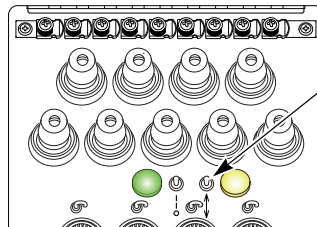

The height of the presser foot will be changed according to the operation of raising/lowering the right switch.

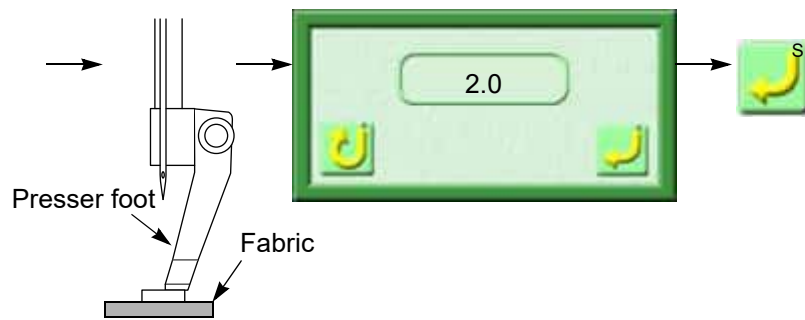
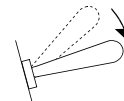

19 Presser foot installation (Input of a password is necessary)

Refer to the separate volume "MACHINE SETUP INSTRUCTIONS".

20 Needle bar upper dead point adjustment (Input of a password is necessary)

Refer to the separate volume "MACHINE SETUP INSTRUCTIONS".

21 Air lifter adjustment (Input of a password is necessary)

22 Bar cord reader adjustment

Refer to the separate volume "BAR CORD READER".

[86 Machine condition]

! CAUTION

⊘ The setting items described below are already set at shipment. Therefore, do not change these settings. Wrong setting could cause trouble in movements of the machine.

1 Machine type, Machine number (Input of a password is necessary)

Set the machine number and the machine type.

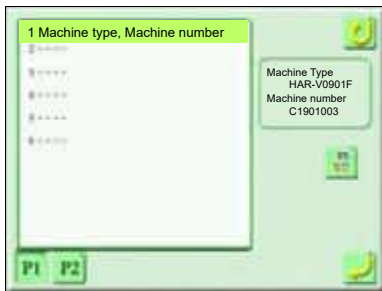

Example: Set Machine Number to "C1901003" and set Number of head to "1".

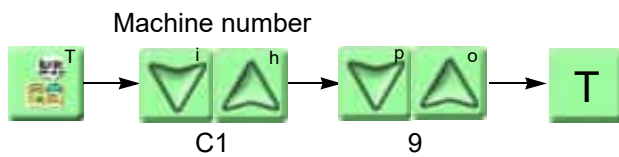

C: 12 needles, F: 15 needles

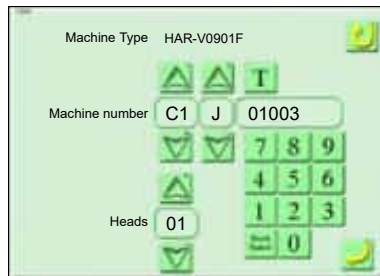
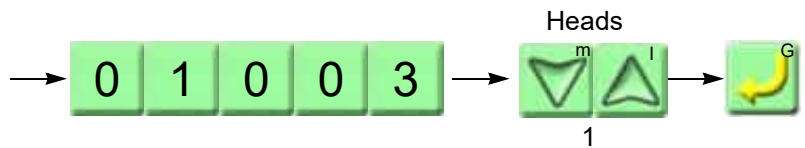

2 X-axis embroidery space (Input of a password is necessary)

Set X-axis embroidery space.

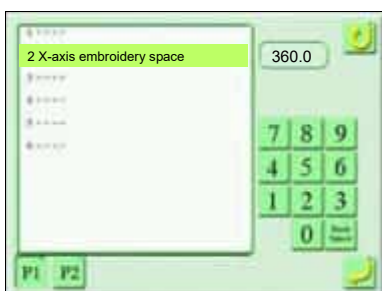

Setting range: 135.0 to 1720.0 mm

Example: 500.0



3 Y-axis frame size (Input of a password is necessary)

Set Y-axis stitching space.

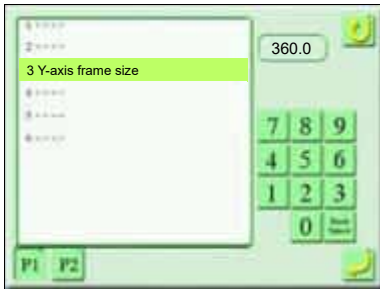

Setting range: 200.0 to 1800.0 mm

Example: 450.0

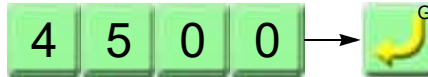

4 Frame spec. (Input of a password is necessary)

Set Frame spec.

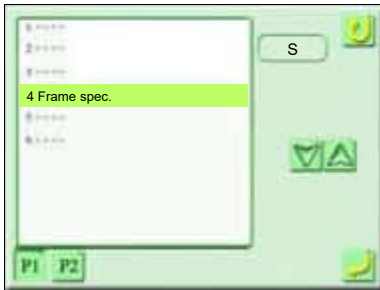

Setting range: S, D, T, Q, DE, T2E, TE

Example: S

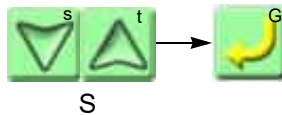

5 Overlap (Input of a password is necessary)

Set Overlap width between heads.



Setting range: 0.0 to 600.0 mm

Example: 0

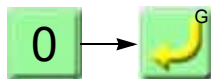

6 Maximum RPM (Input of a password is necessary)

Set the maximum speed.

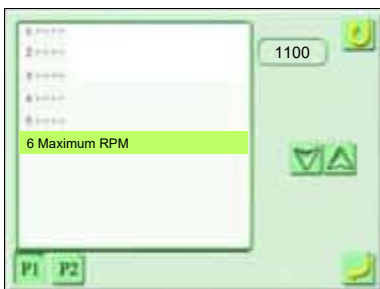

Setting range: 250 to Maximum speed of machine (rpm)

Example: 1100

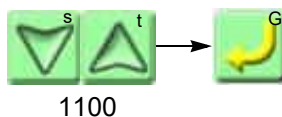

11 Frame weight level (Input of a password is necessary)

Set the frame weight level.

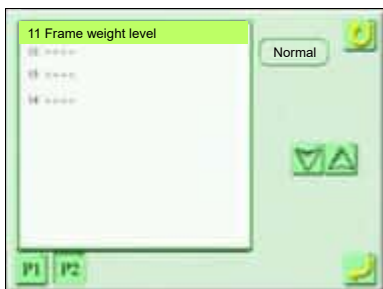

Setting range

Normal, little, minute

Example: Set to "Little".

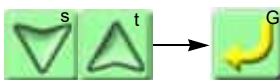

Little

To return to the initial value, refer to the label stuck on the position as shown below figure.

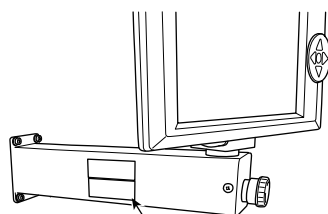

Label

Frame weight level at shipment is described.

12 Available head setting (Input of a password is necessary)

This is the setting to suspend the head occurring trouble and enable other heads to continue sewing.



Setting range

ALL: All heads are selected.

OFF: Selected head is suspended.

ON: Selected head is enabled to stitch.

Example: Suspend the 2nd head.

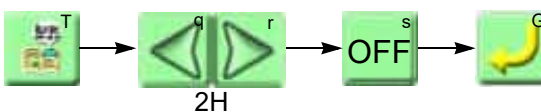

13 X Stitch Length Adjustment (Input of a password is necessary)

Perform fine adjustment of stitch length according to its length.

Perform this function after setting "Frame weight level".



Setting range

1 to 12: Target stitch length (mm)

-60 to +60: Increasing/decreasing amount

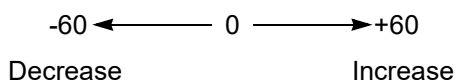

Example: Set 3 mm stitch to 10.

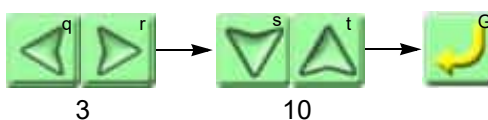

Example: Set 0.6 mm stitch to -10.

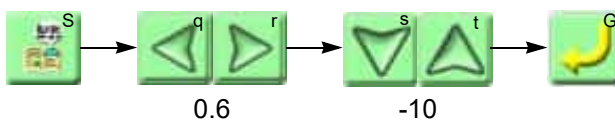

14 Y Stitch Length Adjustment (Input of a password is necessary)

Perform fine adjustment of stitch length according to its length.

Perform this function after setting "Frame weight level".

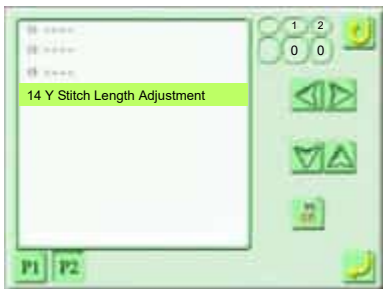

Setting range

1 to 12: Target stitch length (mm)

-60 to +60: Increasing/decreasing amount

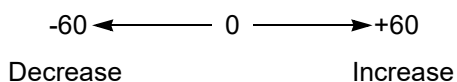

Example: Set 3 mm stitch to 10.

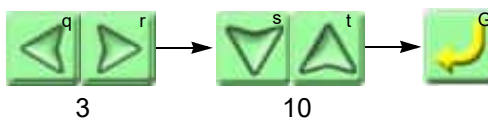

Example: Set 0.6 mm stitch to -10.

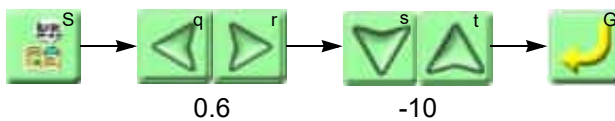

[87 Panel setting]

1 Sound volume (Input of a password is necessary)

Adjust a sound volume of a buzzer.

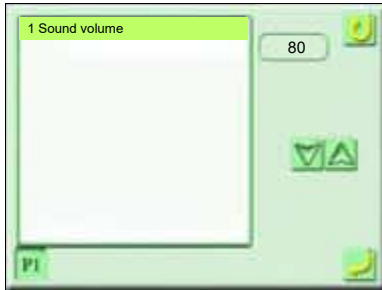

Setting range

80 to 100 (%)

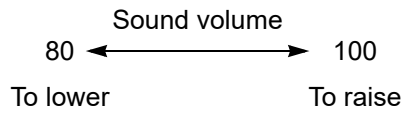

Example: Turn up the sound volume to 95.

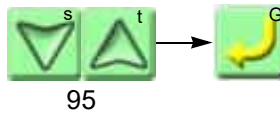

95



Chapter 11

Troubleshooting, maintenance

1. Troubleshooting.....	304
2. Maintenance.....	313
3. Upgrading of software (Input of a password is necessary).....	323

1. Troubleshooting

When the machine stops during operation, an error code will be displayed on the screen.



When the machine stops during operation and a code No. is displayed on the screen, cope with the trouble according to the code chart described below.

1-1. Stop factor (Code No.)

Cord	Stop factor	Corrective Action
0D1-**	Buffer error	Turn OFF/ON the main power. Install the system software.
0D2	Communication parameter error	
0D3-**	Internal-controller error	
1B1	Stop by frame stepping code. Machine stopped due to thread treatment because frame stepping was performed after the start of zig-zag cording device.	After treating thread, continue the operation of the machine if needed.
1B2	Stop by color change code This stop is not caused by an error.	Perform "Start operation" or "Frame Back/ Forward operation", or press any operation key to continue the operation of machine.
1B3	Stop by end code This stop is not caused by an error.	
1B4	Stop by thread trimming code This stop is not caused by an error.	
1B5	Stop by sequin code This stop is not caused by an error.	
1B6	Stop by automatic arbitrary offset code This stop is not caused by an error.	Perform "Start operation" or "Frame Back/ Forward operation", or press any operation key to continue the operation of machine.
1B8	Stop by temporary stop code This stop is not caused by an error.	
1C1	Stop by the stop button Machine stopped by operator s operation.	Continue the operation of the machine if needed. By turning OFF the main power during 1C1 indication, the embroidery may not be continued.

Cord	Stop factor	Corrective Action
1C3	Halt by input of external stop signal Machine stopped by the stop signal from an external device.	Continue the operation of the machine if needed.
1C4	Stop by switch operation of tension base M/C stopped by the change of tension base switch from clutch to normal during color change SQ/ Zigzag cord.	Perform "Start operation" to continue the operation of machine if needed.
1C5	Installation interrupted. Software installation was interrupted by operator s operation.	Press reset key and select Retry.
1D1	Halt at Frame Back start point Machine stopped by the halt setting at the start point of embroidery for all heads after Frame Back operation.	Perform "Start operation" to continue the embroidery.
1D2	Preset Halt Machine stopped by the preset halt setting.	Reset by pressing the reset key. Perform "Start operation" to continue the embroidery.
1D4	Pause (Temporary halt) by data preparation	"Now processing" is displayed. Wait until the indication goes out.
1D5	Preset halt (Lochrose) Machine stopped by the preset halt (Lochrose) setting.	Reset by pressing the reset key. Check/ replace the beads. Perform "Start operation" to continue the embroidery.
1D6	Receipt of PCB-reset request Transmit a message to reset request in the middle of embroidery.	"Now processing" is displayed. Wait until the indication goes out.
211--01	Fixed position signal error Machine stopped at other than the fixed position.	Return the main shaft to the fixed position. Adjust encoder/encoder Z signal.
211--02	Fixed position signal error Machine stopped at other than the fixed positions of main shaft and needle position.	Return the main shaft/needle position to the fixed position. Adjust the encoder/encoder Z signal.
211--03	Fixed position signal error Machine stopped at other than the fixed position of main shaft during power resume.	Adjust the encoder/the encoder Z signal. Initializing the error code causes frame origin search starts after the main shaft moves to the fixed position automatically.
211--04	Fixed position signal error Encoder Z signal cannot be detected due to poor encoder adjustment even when the main shaft is at the fixed position.	Check the encoder. Adjust the encoder so that the mechanically fixed position synchronize to the encoder Z signal correctly.
212	In the state of needle bar lowered Needle bar is descending.	Move needle bar up and operate the machine.
213	Lower dead point error Machine is stopping at the lower dead point.	Move needle bar up and operate the machine.

Cord	Stop factor	Corrective Action
221	Frame Too Far Left Embroidery frame moved to the limit position (left). (+X direction)	Move the frame manually to embroider within the setting of embroidery space.
222	Frame Too Far Right Embroidery frame moved to the limit position (right). (-X direction)	Move the frame manually to embroider within the setting of embroidery space.
223	Frame Too Far Front Embroidery frame moved to the limit position (front). (+Y direction)	Move the frame manually to embroider within the setting of embroidery space.
224	Frame Too Far Back Embroidery frame moved to the limit position (rear). (-Y direction)	Move the frame manually to embroider within the setting of embroidery space.
225	Design size too large Design does not fit within the embroidery space due to the present start position of design.	Move the frame manually to embroider within the setting of embroidery space.
251	Lubrication level error Lubrication level is irregular.	Supply oil to the lubrication tank.
258	Upper dead point sensor error Upper dead point sensor error detected.	Check/replace the upper dead point sensor of color change sequin device.
259	Lower dead point sensor error Lower dead point sensor error detected.	Check/replace the lower dead point sensor of color change sequin device/zigzag cording device.
25A	Sequin color change sensor failure Color change sensor error detected.	Check/replace the color change sensor of color change sequin device.
291	Stop by detecting thread breakage Machine detected upper thread breakage.	Check the upper and under threads. Check/replace the tension base card.
292	Irregular material detected Error occurred on the material feeding of zigzag cording device.	Check/replace the material. Check the card, harness etc. of zigzag cording device.
293	Under thread break Machine detected under thread breakage.	Check the under thread. Check/replace the tension base card.
294	Absence of material detected Machine detected absence of sequin material.	Check/replace Sequin material.
2A1	Thread trimming position adjustment error Adjustment time of thread trimming position was exceeded.	Return ATH movable knife to the correct position. Check and replace the thread trimming motor/thread trimming encoder.
2B2	TAJIMA Complement error Complement error detected in TAJIMA Tape data.	The same values (+ and -) of the design data are valid at the same time. Correct the design data.
2B3	Data found in end code Data is found in end code.	Delete "X/Y moving amount of the end code" of the design data.

Cord	Stop factor	Corrective Action
2B4	Function code error Function code error occurred.	There is a function code that is not defined. Correct the design data.
2B7	Data set incomplete Data set is not completed.	Operate the machine after setting the data of embroidery design.
2B8	Frame Forward limit over Frame Forward exceeded available range.	Frame Forward is not available beyond the current stitch count.
2B9	Memory write error Cannot write data onto memory.	Check and replace CPU card/operation panel.
2BA	Memory capacity exceeded Free space of memory is insufficient.	Increase the free space of memory by removing unnecessary designs in the designs registered in the memory (after taking the backup if needed).
2BB	Frame Back limit over Frame Back exceeded available range.	Frame Back is not available before the current stitch count.
2BC	Design No. error Design No. cannot be found. Not editable due to data setting. Design is not registered in memory.	Edit the design you wish to edit after the data set of the design. Register the design to the memory.
2BE	Incorrect function code segment Start/end codes are not registered in a pair for the function which has start/end.	Modify/set the design again so that the codes of start/end become a pair.
2BF	Memory read error Memory cannot be read.	Check and replace CPU card/operation panel.
2C1	Insufficient program setting	Operate after coming out of parameter setting screen/the other setting screens/manual operation screen.
2C7	Password requested Password is requested. The input password is wrong.	Input the password.
2CE	Stop by safety device Machine was stopped by the stop signal from the safety device.	After confirming safety, continue the operation of machine if needed.
2E2	Air pressure error Air pressure has become lower than the standard level.	Check/adjust the pressure of air supplying.
2E3	Power failure during operation The power supply was shut off during main shaft operation.	Turn ON the main power and perform the operation of power resume.
311-**	Encoder A signal error	Check the encoder or encoder signal lines. Check the excitation of the main shaft driver.
312-**	Encoder Z signal error	Check the encoder or encoder signal lines.

Cord	Stop factor	Corrective Action
314-**	Main shaft revolution error (Overload error)	After checking around the rotary hook and the main shaft, remove the factor that the main shaft can not rotate.
316-**	Main shaft motor error	Turn OFF/ON the main power.
319	Main shaft stopped by embroidery data reception error. It was not possible to receive stitch data during two rotations of main shaft.	Turn OFF/ON the main power. Check/replace the main shaft motor/main shaft driver.
321-**	Frame driver irregular signal	Lower the revolution of the main shaft. Check/replace the XY-axis driver card/frame motor.
322	X-Driver irregular signal	Turn OFF/ON the main power. Check/replace X-axis driver card.
323	Y-Driver irregular signal	Turn OFF/ON the main power. Check/replace Y-axis driver card.
32C	X-axis frame travel incomplete	Turn OFF/ON the main power. Check/replace X-axis driver card.
32D	Y-axis frame travel incomplete	Turn OFF/ON the main power. Check/replace Y-axis driver card.
32E	X-axis origin search incomplete	Check the embroidery space setting. Check/replace the sensor card.
32F	Y-axis origin search incomplete	
352	Sequin device IV driver error	Check/replace Sequin device IV card.
353	Sequin device III driver error	Check/replace Sequin Device III card.
354	Motor overcurrent	Turn OFF/ON the main power. Lower the revolution of the main shaft. Check/replace the head card.
361-**	Jump Driver signal error	Turn OFF/ON the main power. Lower the revolution of the main shaft. Check/replace the head card.
376	Presser foot position error	Set the presser foot to the retractable position.
378-**	Presser foot driver error	Turn OFF/ON the main power. Lower the revolution of the main shaft. Check/replace the head card.
379-**	Error detection of Hook driver	Turn OFF/ON the main power. Check/replace the hook motor/head card.
382-**	Time to move to target position	Check/replace the color change motor/encoder and potentiometer (needle position sensor).

Cord	Stop factor	Corrective Action
383-**	Needle position error	Move the needle position within the set range. Check/replace the potentiometer (the needle position sensor) or the color change encoder.
384	One-turn signal is not detected	Check/replace the photo interrupter (1-rotation sensor) and color change encoder.
388-**	Color change driver error	Turn OFF/ON the main power. Check the change device. Check/replace the controller card.
3A1-**	ATH Driver signal error	Turn OFF/ON the main power. Check/replace ATH motor/controller card.
3A2	Time out for ATH	Check if thread is crowded. Turn OFF/ON the main power. Check/replace ATH motor/controller card.
3A3	Upper Thread Lock Driver	Turn OFF/ON the main power. Check/replace the head card.
3A6	Movable Knife Open	Check the position of ATH movable knife.
3AB	ATH thread separation error	Set Tension base SW at the detected head to the top and make LED lit green. Then press the reset key or start by the bar switch.
3AC	ATH Skip stitch error	
3B4	Communication error	Check/replace the head card.
3B6	Communication error	Check/replace the driver card.
3B8	Sequin device twin type error	Check/replace Sequin device III card.
3B9	Up/Down Color change driver com. error	
3BE-**	Network communication error	Check the setting of network connection. Turn OFF/ON main power of machine and connecting device such as DG/ML. Check connecting cable.
3BF	Lochrose counter	Check/replace the head card.
3C1	Start/Stop switch error	Check/replace the connector/connection terminal/limit switch. Turn OFF/ON the main power.
3C2-**	Frame travel key error	Check/replace the frame moving switch. Turn ON the main power supply.
3D1	Battery signal error	Charge/replace the battery of the operation panel.
3D2	Battery signal error	Charge/replace the battery of CPU card.

Cord	Stop factor	Corrective Action
3D4	ROM Check Sum error	Turn OFF/ON the main power. Install the system software. Check/replace CPU card.
3D5	RAM Check Sum error	
3D6	Watch Dog error	
3D7	RAM error	
3D8	CPU exception handling error	
3D9	Fan Motor error	Replace the fan motor for the power supply box/operation panel.
3DA	Permanent Counter error	Check/replace the connection of permanent counter.
3DB	System RAM insufficient capacity	Turn OFF/ON the main power. Install the system software. Check/replace CPU card.
3DC	Memory device error	
3DD-**	System installation error	After pressing the reset key, install again by pressing the retry key. After turning OFF/ON the main power, install again. Check/replace CPU card.
3DE	External memory device error	Turn OFF/ON the main power. Check/replace the external memory media. Check/replace CPU card.
3DF	Memory device broken	Turn OFF/ON the main power. Check/replace CPU card.
5B1	Design information error	Replace the design data. Use the design data made by DG/ML.
5C1	Frame origin memory incomplete	Perform the operation of absolute origin search.
5C2	Sequin device in operation	Do not operate the machine when Sequin Device is moving up and down.
5C3	Sequin device twin type setting error	Check/change the parameter setting of sequin device on operation panel.
5C6	General external device is operating.	Do not operate the machine during the operation of general external device.
6B1	Communication error	Check/replace Sequin Device IV card.
6B2	Communication error	Check/replace the main shaft driver card.
6B3-**	Logger communication error	Turn OFF/ON the main power. Check/replace the Logger card.
6B5-**	Communication error	Turn OFF/ON the main power. Install the system software. Check/replace each card.
6D1	Frame parameter file error	Install the system software.

Cord	Stop factor	Corrective Action
6D2	Disconnection of communication line	Turn OFF/ON the main power. Check the connection of each harness. Install the system software.
6D3	Communication error	
6D4	SHT connection error	Connect the harness for SHT control.
6D5	Power interruption detector connection error	Connect the harness for the detection of power failure.
OIL	Preset Halt Machine stopped by the preset halt (Lubrication) setting.	After lubricating the necessary spots, reset the machine by the reset key. Perform "Start operation" to continue the embroidery.
B01	Formatting error Abnormal format of storage media. Reading/writing error occurred.	After taking the backup, format the memory media. Use the new memory media.
B02	Disk FAT error Abnormal File Allocation Table found on.	Take the backup of memory media. Do not use the memory media that caused error.
B03	Write protect error The memory media is write-protected.	After cancelling the write-protection for memory media, perform the writing operation.
B04	Empty media error Media is not inserted.	Insert memory media.
BC1	Unregistered design No. Design No. is not found.	Perform the selection of design again.
BC2	Design name overwrite error The same design name already exists in USB Memory/FD.	Change the file name.
BC3	Disk file error This memory media cannot be read.	After taking the backup, format the memory media. Use new memory media.
BC4	Verify error Abnormal Stitch Data found on Media.	Perform writing again.
BC5	Memory capacity insufficient error	Replace with a memory media with enough remaining capacity. Then, by pressing the reset key, the operation will continue.

1-2. When the machine does not sew well

(1) Thread breakage

Cause	Corrective Action
Bad thread tension	Adjust tension.
Poor thread flow	Use silicone.
Direction of needle is bad. Bent	Adjust to face to the front or to the right a bit. Replace.
Applique glue is stuck on needle.	Remove adhered glue.
Contamination, run-out of oil of rotary hook	Clean and lubricate. (→p.314)
Many minute stitches of 0.5 mm or less in design data	Remove minute stitch(es).
The fabric is lifted too much against the needle plate. The fabric touches the needle plate excessively.	Stretch the fabric again so that it touches needle plate lightly.
Run-out of oil of needle bar	Lubricate. (→p.317)
There is a scratch on the thread course.	Grind a scratch with sandpaper etc. Replace them.
Bad height of presser foot	Perform adjustment so that height fits to fabric/material.

(2) Needle breakage



Cause	Corrective Action
Bad thread tension	Adjust tension.
Density of design data is very high.	Correct data. Delete unnecessary underlay stitching.
The material is too thick or hard.	Use material suitable for embroidery.
Bobbin is deformed and it touches the needle.	Replace the bobbin.
Deterioration of needle, mis-matching to sewing condition	Replace needle. Use needle that fits to condition.
Vibration of the machine is big.	Center support is too much touched to the table. Tighten the support by hand. Adjust leveling.

(3) Bad finishing of embroidering



Cause	Corrective Action
Bad thread tension	Adjust tension.
Density of design data does not match with material and/or thread.	Correct data.
Bad frame attaching and fixing of the fabric	Attach the frame correctly. Fix the fabric firmly.
Thread, needle and/or size of needle plate do not match with embroidery.	Make combination that fits to design data/material.
R.P.M. is too high.	Decrease R.P.M.

2. Maintenance

WARNING

-  Daily maintenance (cleaning, lubrication, greasing, inspection) should be performed by personnel who has been trained properly.
-  If the machine needs "repairs", the repairs must be done only by the service personnel assigned and trained by Tajima or qualified technician (consult your distributor.)
-  When starting operation again, attach all the detached covers as they originally were.

CAUTION

-  Perform daily maintenance. Neglect of daily maintenance could cause troubles. Damage due to neglect of daily maintenance may be judged as "Outside the scope of warranty".
-  Some electric cards may be equipped with a CMOS battery for data storage. The battery's lifespan is approximately 5 years. Please be aware that when the battery rundown, symptoms such as resetting of time and date, or parameter setting may occur.
-  Assure enough illumination. Assure 300 lux or more for working areas including underneath part of the machine table when changing under threads or performing daily maintenance.

2-1. Cleaning

WARNING

 When performing cleaning, be sure to turn OFF the power switch. You could be injured seriously by being entangled in the machine.

Clean each section by using a cleaning tool or an air compressor, etc. on the market.

(1) Rotary hook, ATH

Cleaning cycle: Every day

Example when using a cleaner

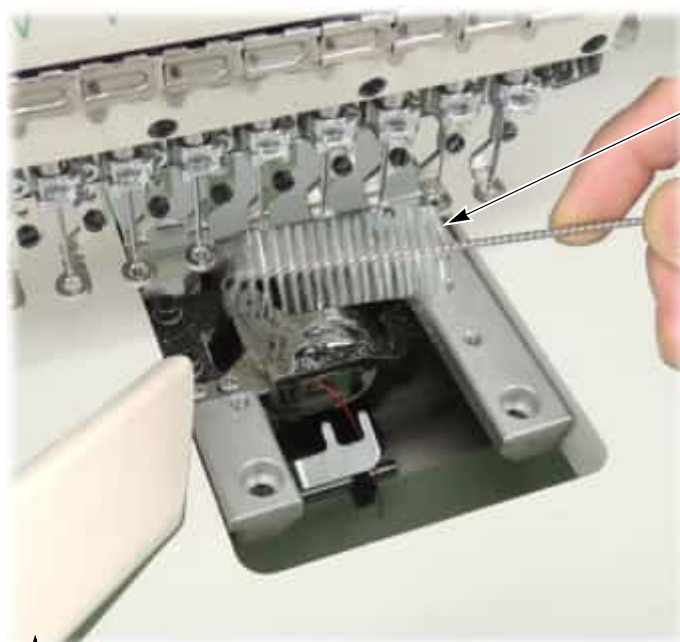

Brush (accessory)



Cleaner

An example when using an air compressor

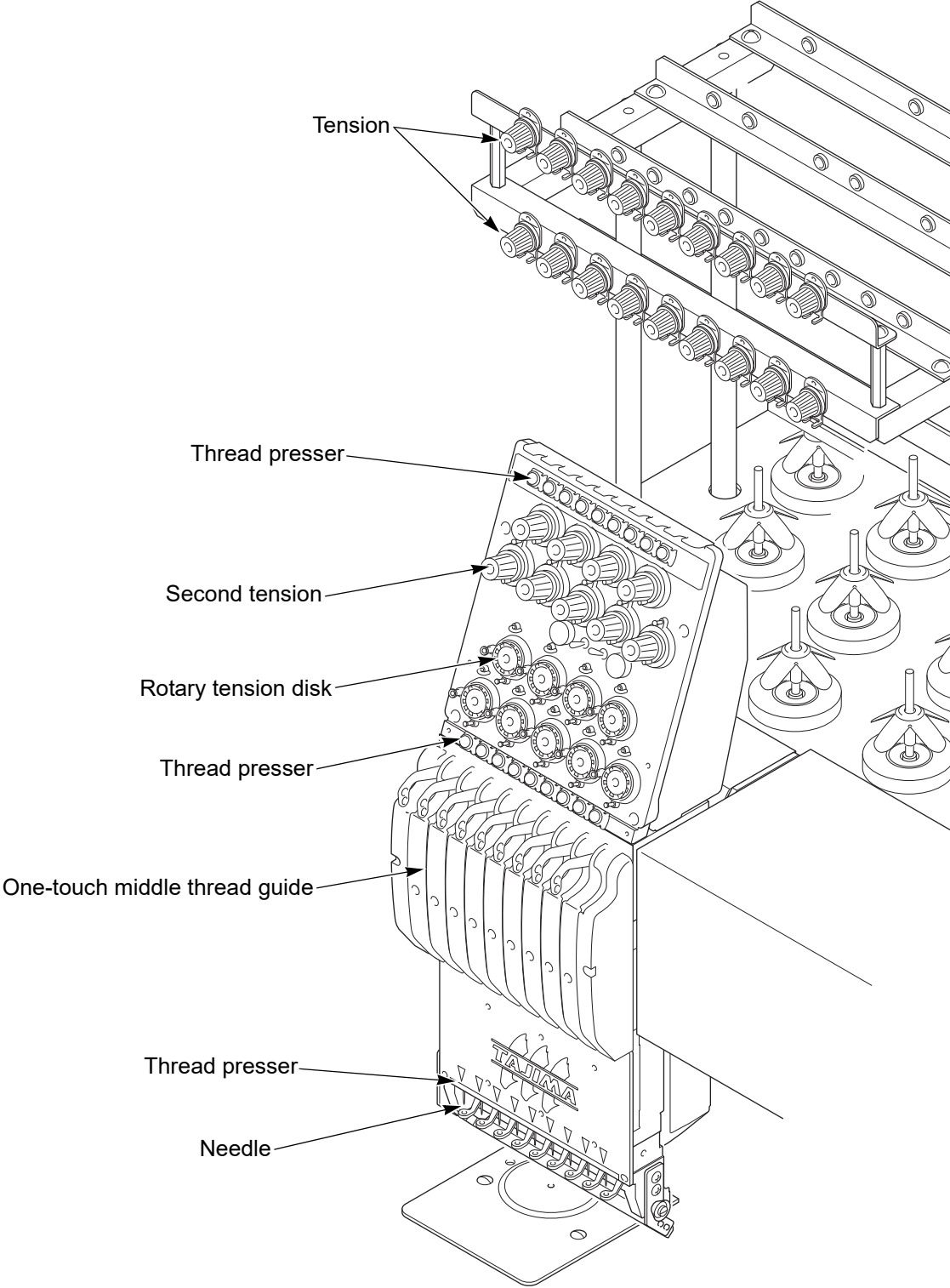

(2) 1st tension, head

Cleaning cycle: Once/week



(3) Presser foot shaft

The motion of the presser foot shaft may be getting poor because of adhering thread and dust. Clean the surrounding of the presser foot shaft using an air compressor or an brush periodically.

Cleaning cycle: Twice/week

a. Lower the right switch on the tension base twice. The presser foot of that head will lower to the lower dead point.

It is possible to lower the presser feet at all heads all together. (→p.125)

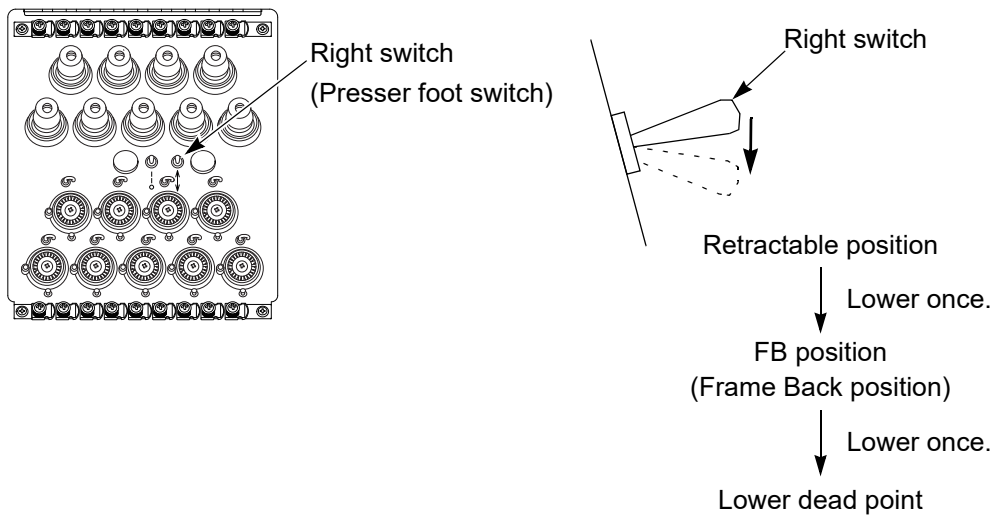

b. Clean the presser foot shaft.



An example when using an air compressor

2-2. Lubrication

! WARNING

- ! To perform lubrication, turn OFF the power switch. You may sustain severe injuries by being caught in the machine.

! CAUTION

- ! Use only Tajima s genuine TF oil or equivalent (Viscosity grade = VG20).

(1) Rotary hook

Lubrication cycle: Once/5 to 6 hours

To lubricate, use the oiler. There are two lubricating spots, raceway and lubrication hole.

Oiler (accessory)

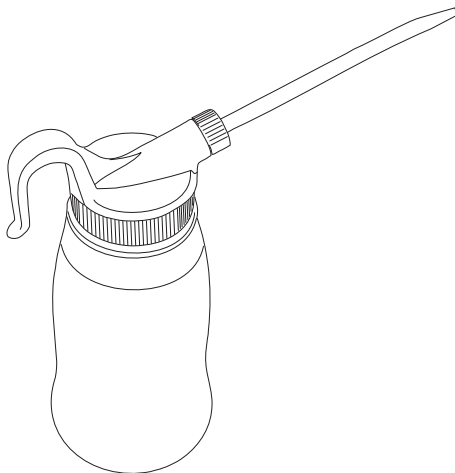

Raceway

Lubrication hole (red mark)



To lubricate to lubrication hole, attach the nozzle (accessory) to the tip of the oiler.



Nozzle

(2) Head

Lubrication cycle: Once/3 months

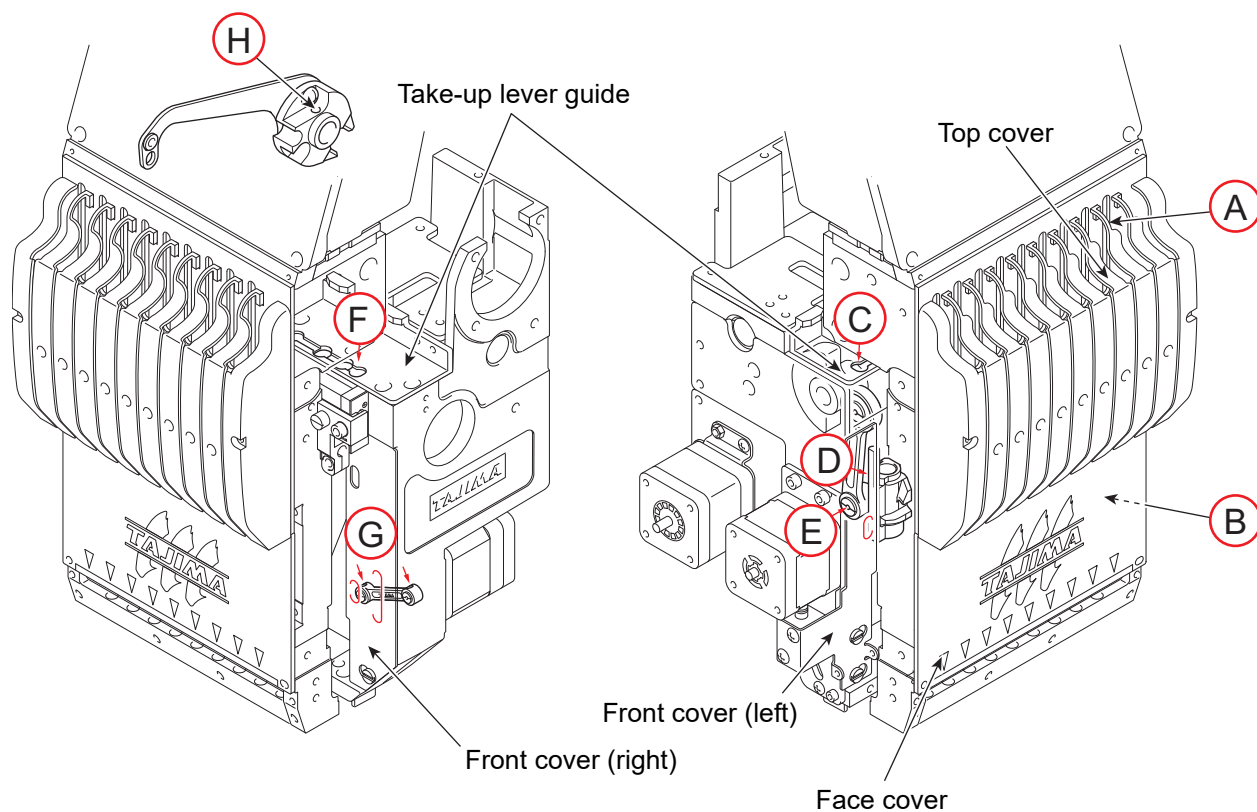

Lubricating spot	How to lubricate
A: Needle bar	Lubrication from top cover (→p.319)
B: Needle bar, Presser foot shaft	Detach the face plate and lubricate. (→p.319)
C: Needle bar drive shaft (needle bar side)	Lubricate from hole of take-up lever guide.
D: Needle bar reciprocator	Lubricate into hole (red) of front cover (left).
E: Connecting rod (needle bar side)	
F: Needle bar drive shaft (presser foot side)	Lubricate from hole of take-up lever guide.
G: Connecting rod (presser foot side)	Lubricate into hole (red) of front cover (right)
H: Take-up lever boss ^[1]	Lubricate by detaching top cover.

[1] Take-up lever boss

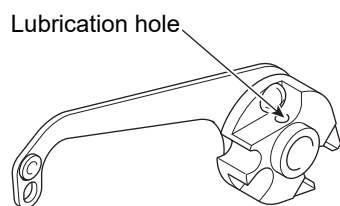

[How to lubricate to needle bar and presser foot shaft]

a. Remove the screws at two spots.

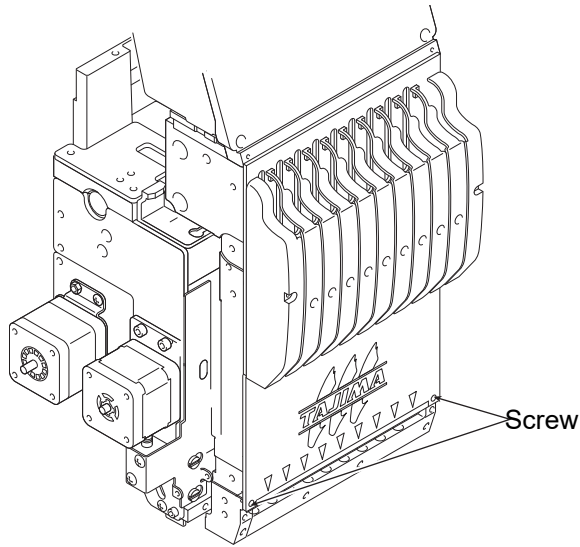

To play the video, Adobe Flash Player is necessary. Press the play button as shown above, and follow the displayed screen to install Adobe Flash Player.

To close the video, scroll down to the next page.

b. Lubricate to some of the spot as shown below.



Needle bar (upper part)
A in the right figure



Presser foot shaft
B in the right figure



Needle bar (lower part)
C in the right figure

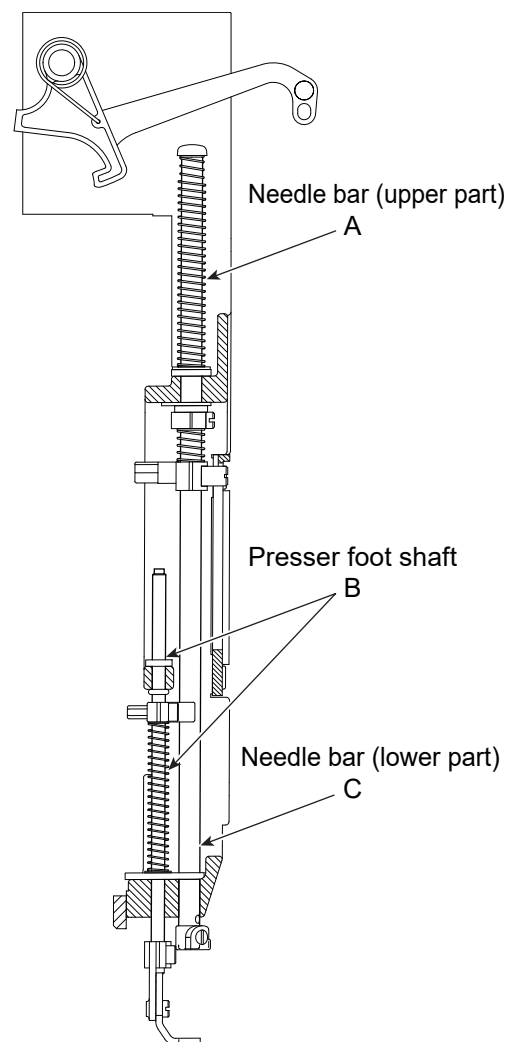

2-3. Greasing

When you perform greasing, consult the distributor.

! WARNING

- ! During machine greasing, turn OFF the power switch. You may sustain severe injuries due to being entangled by moving machine units.

! CAUTION

- ! Use a grease specified(described below) by TAJIMA or equivalent to keep the lubricity inside of the head normally. Use of the grease except these could cause trouble due to deterioration of the lubricity. Regarding how to obtain it, consult the distributor.

[Items specified by TAJIMA]

Part name	Item No.	Base oil	Thickener
GREASE :KING STAR EP NO.2 :400G	750103004000	Refined mineral oil (about 75%)	Lithium soap (about 15%)
SPRAY GREASE :NIG LUBE PG :300ML	750104001000	Olefinic synthetic oil	Lithium soap
GREASE :NIG ACE U-2 :400G	750103003000	Refined mineral oil (about 85%)	Urea (about 10%)

Grease manufacturer: NIPPON GREASE Co.,Ltd.

URL : <http://www.nippon-grease.co.jp>

(1) Rotary hook base

Grease to use: KING STAR EP NO.2: 400G

Greasing cycle: Once/6 months

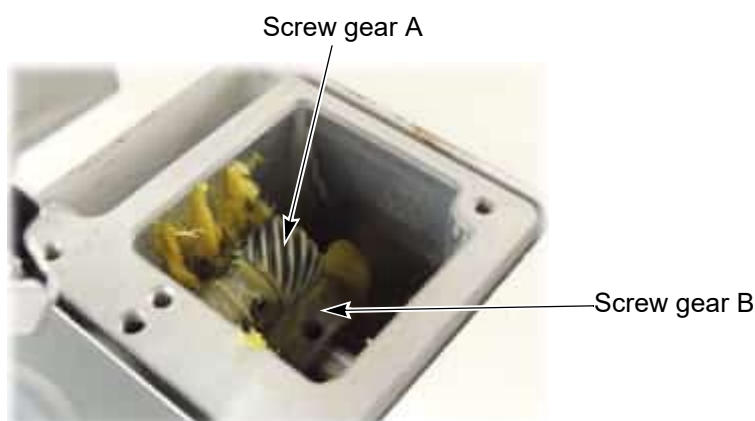

(2) Head

Greasing cycle: Once/6 months

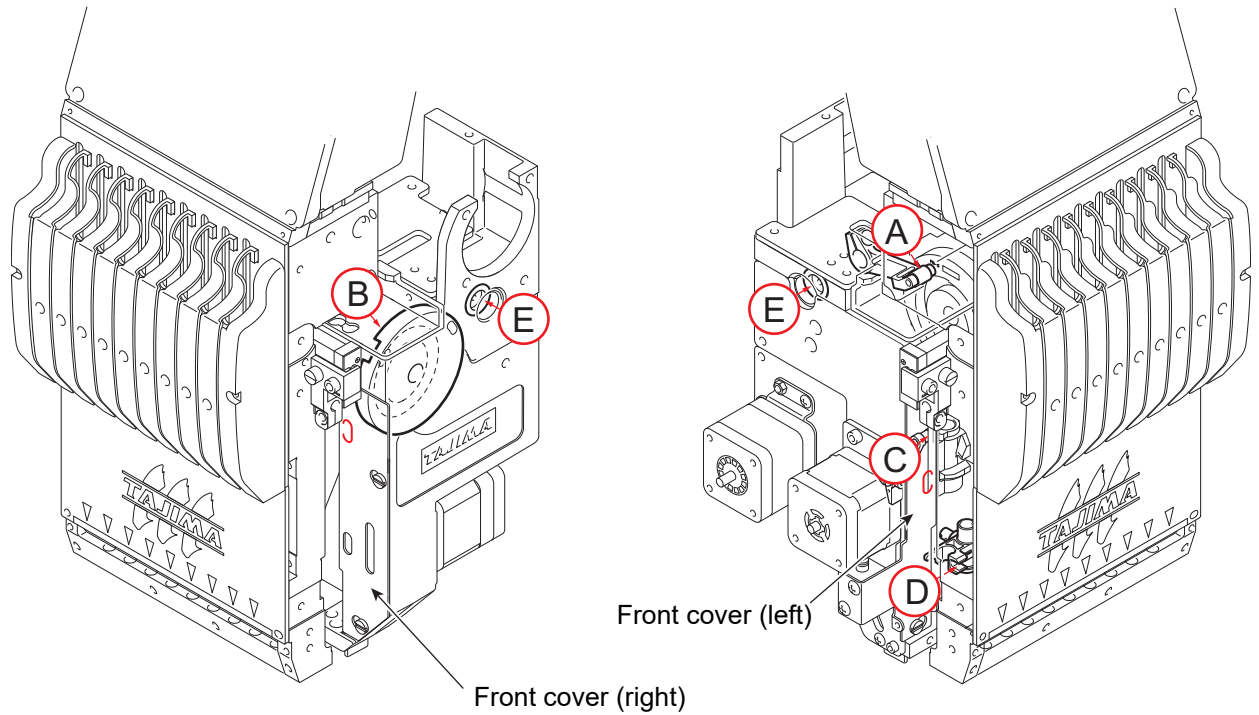

Grease to use

A to D, F: NIG LUBE PG :300ML

E: NIG ACE U-2: 400G

Greasing spot	How to grease up
A: Take-up lever roller	Slide the needle bar case to the direction of the last needle and grease up.
B: Take-up lever cam	Greasing through hole (red) in front cover (right)
C: Jump lever	Greasing into hole (red) on front cover (left)
D: Presser foot reciprocator	Slide the needle bar case to the direction of the last needle and grease up.
E: Take-up lever shaft holder	Greasing by syringe, etc.

2-4. Inspection

WARNING

 Be sure to turn off the main power supply before working. Even if the main power supply is turned off, some circuits are still applied voltage. Wait until they are not applied voltage completely (4 minutes), and then start working.

Inspection point	Contents of inspection	Inspection cycle
Each belt in main shaft drive system	Tension of belt, degree of wear, existence of crack	Once/3 months
X- and Y-axis drive belts	Tension of belt, degree of wear, existence of crack	
Rotating, sliding section	Degree of wear	

2-5. Repair

WARNING

 If the machine needs repairs, the repairs must be done only by the service personnel assigned and trained by Tajima or qualified technician. (consult your distributor.) Do not change the specification nor modify the parts of the machine without due consultation with Tajima. Such modification may risk the operational safety.

 Be sure to turn off the main power supply before working. Even if the main power supply is turned off, some circuits are still applied voltage. Wait until they are not applied voltage completely (4 minutes), and then start working.

 When restarting the machine after repairs, attach all removed covers etc. as they were.

CAUTION

 For the machine repairs, use TAJIMA genuine parts for replacement.

3. Upgrading of software (Input of a password is necessary)

The latest software at shipment is installed to the machine. When upgrading of the software is necessary in later use, install the latest software according to the following procedure.

Regarding the contents and how to obtain the latest software, please consult the distributor.

To perform this work, input of the password is necessary. After input of the password, the following operation will become possible until you turn ON the power again next time. For details, consult the distributor.

[Explanation of screen]

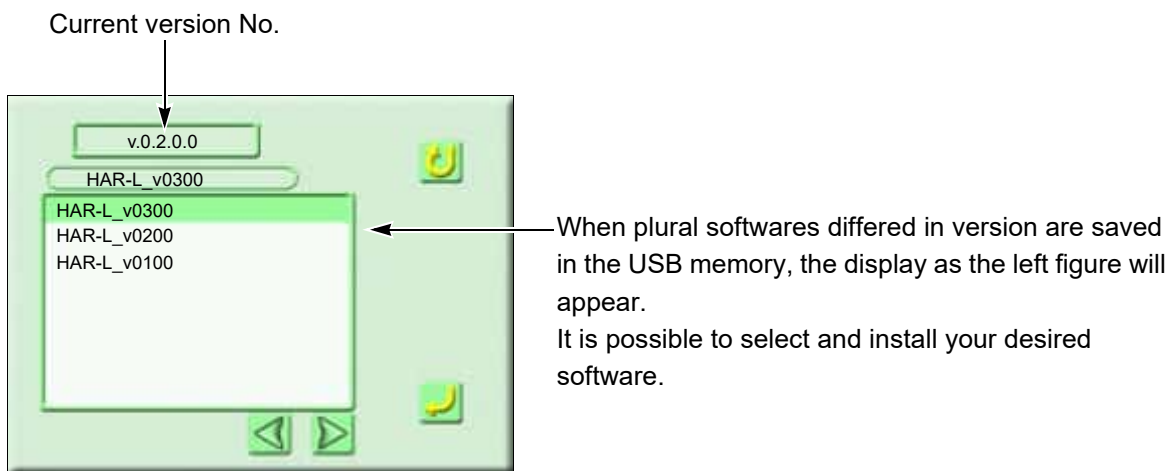

[How to operate]

(1) To set USB memory

USB memory in which software is saved

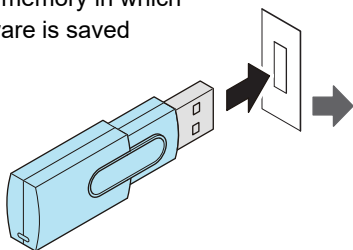

(2) Icon G



(3) Press P6 twice.

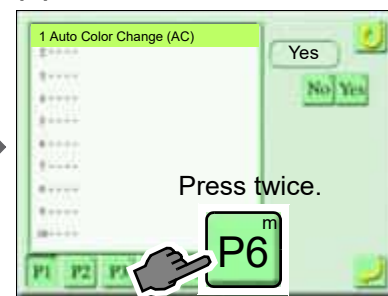

(4) Icon S

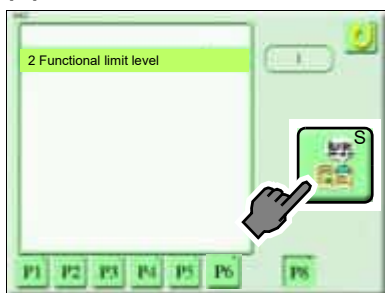

(5) Input a password.



(6) To set



(7) SEL

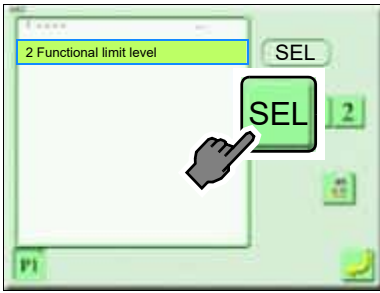

(8) Icon T

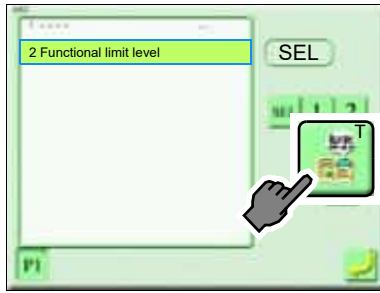

(9) ALL Yes

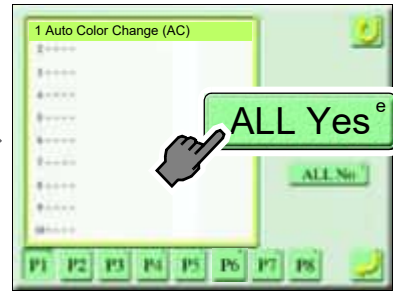

(10) To set

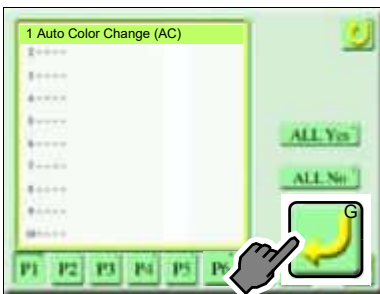

(11) To set

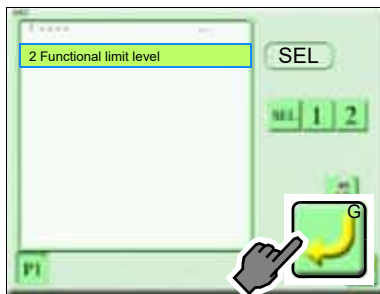

(12) Icon A

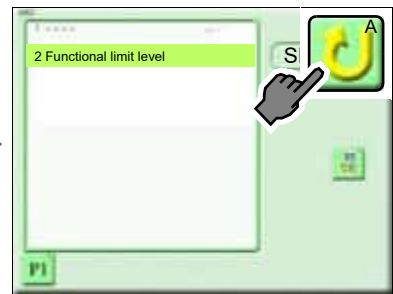

(13) 85 Machine adjustment

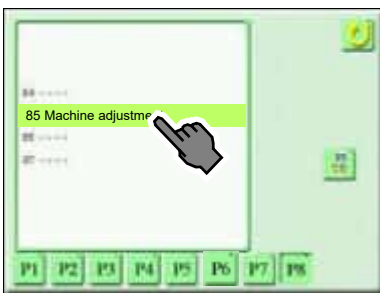

(14) Icon T

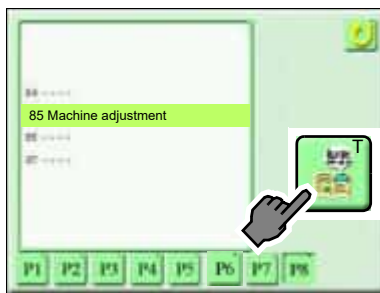

(15) P2

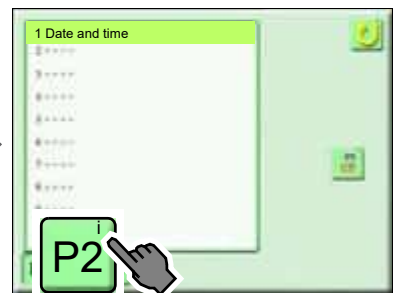

(16) 15 Software install



(17) Icon T



(18) To set



(19) A desired software to set



(20) Default (Recommended)

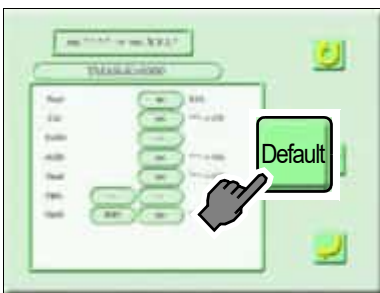

(21) To set

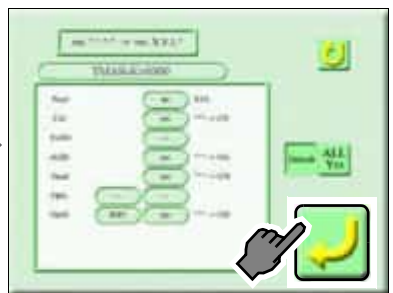

Now processing

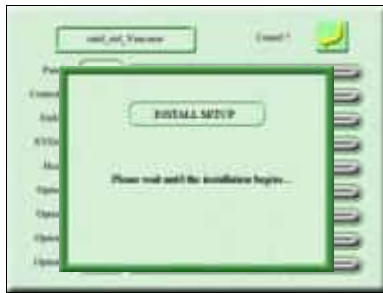

Now processing

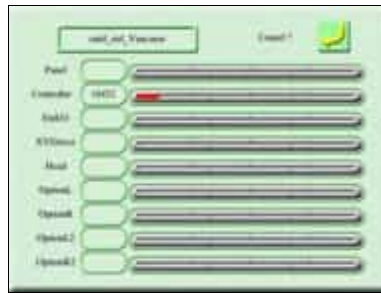

Completed.



(22) Pull out the USB memory.

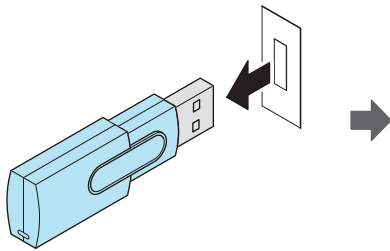

(23) Turn OFF and ON the power. At this moment, wait for twenty seconds or more. (Completed)

Chapter 12

Appendix at the end of the manual

1. Specification of the machine.....	328
2. To use this machine as the embroidery machine	330

1. Specification of the machine

1-1. Ambient noise level

The ambient noise level of the machine is less than 85 dB. Measuring conditions are as follows.

Measuring ambience	Refer to the figure below.
Measuring position	Measured at the position A which height is 1.6 m from the floor and the distance is 0.3 m from the front of the operation panel
Working machine condition	Fabric is stretched on the tubular goods frame or the border frame, and embroidery with stitches 2 mm in length will be executed.
RPM	Maximum number of revolutions of machine
Measuring instrument	Conformity to IEC61672-1: 2002 Class 1

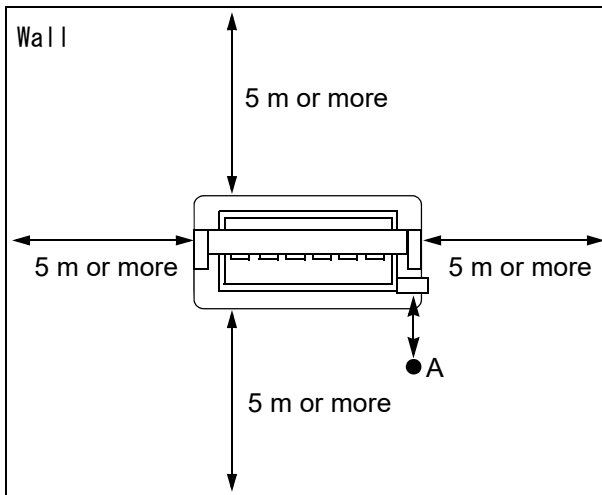

1-2. Power supply specifications

Allowable voltage range	Within $\pm 10\%$ of the rated voltage
Frequency	50 / 60 Hz
Apparent power	8-head machine: 900 VA (Maximum)
Active power	8-head machine: 700 W (Maximum)
Insulated resistance	10 M ohms or greater (500 megger insulation tester)

1-3. Machine weight

Machine weight is described on the spec. plate.

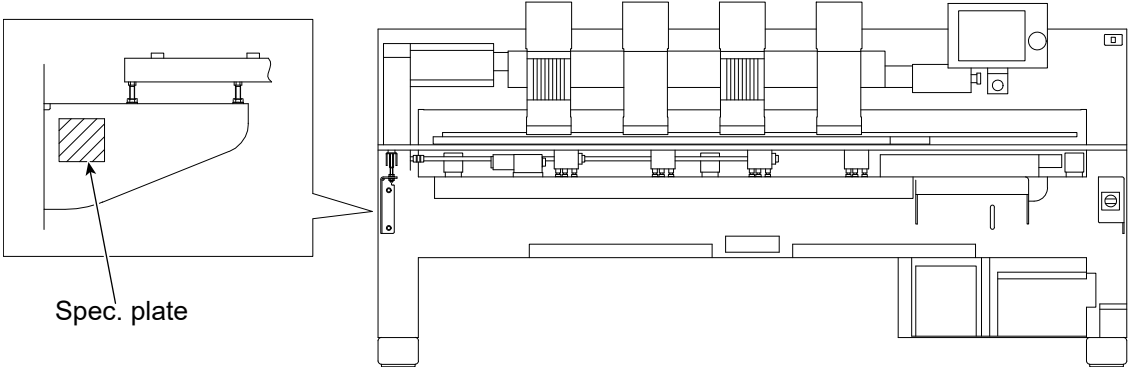



2. To use this machine as the embroidery machine

Although this machine is designed as the sewing machine, it can be used also as the embroidery machine by replacing parts in the chart below.

2-1. Recommended parts

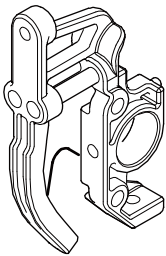
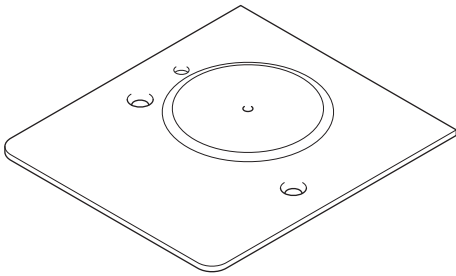
Prepare the following parts. For details, consult the distributor.

<p>BASE : MIDDLE THREAD GUIDE :0.4 MM DIA.[A] (090210401A10)</p>  <p>One piece is necessary for one needle</p>	<p>NEEDLE : 2 MM DIA. (050340090020)</p>  <p>One piece is necessary for one head</p>
<p>TAPER SPRING :0.6 MM DIA. (507706010000)</p>  <p>It varies depending on the thread course. Refer to the figure A below.</p>	<p>NEEDLE :DB-K5Z1 #11^[1] (616500080000)</p>  <p>One piece is necessary for one needle</p>

[1] "NEEDLE :DB-K5Z1 #11" is the standard type needle. Select according to the embroidery thread and the fabric, etc. to use.

Figure A

The number of replacement of "TAPER SPRING :0.6 MM DIA." differs depending on the type of the thread course (two steps type, one step type).

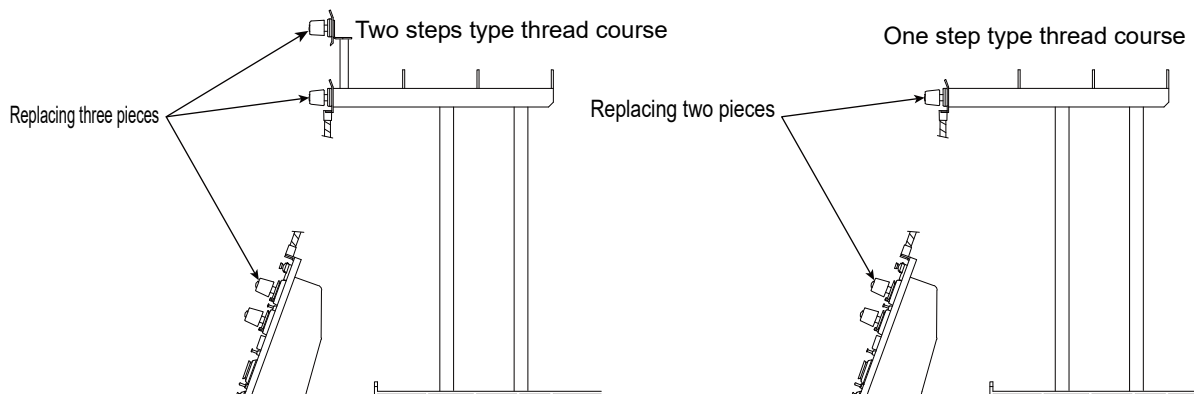

2-2. Replacement of each part

CAUTION

 When attaching each part, turn "OFF" the power switch. Performing works with the power "ON" could cause unexpected malfunctioning of the machine, and you could be injured.

The following process is the example of replacing the parts for 5th needle.

(1) Middle thread guide base

a. Remove the screw 1 to detach the front face cover.

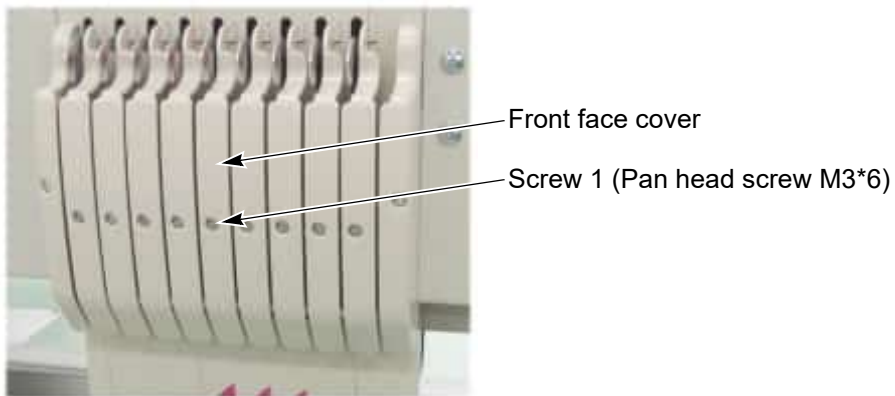

b. Remove the screw 2 to detach the middle thread guide base 0.7 mm dia. spec.

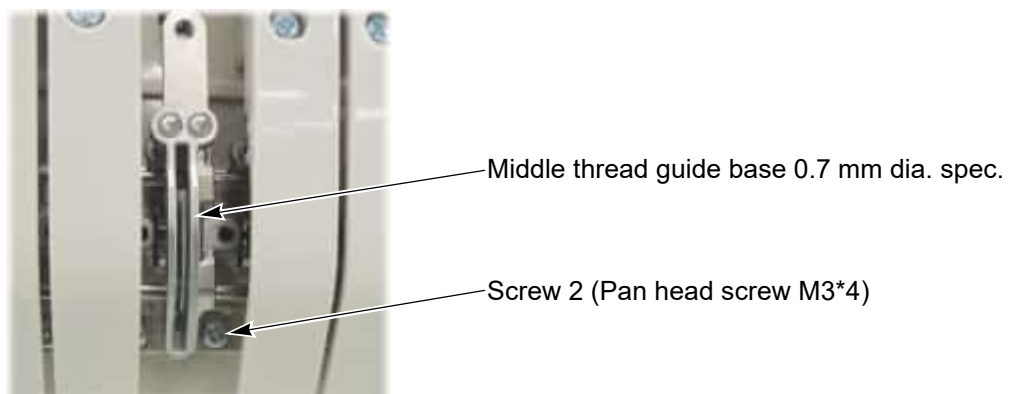

- c. Insert the protruding part of the middle thread guide base 0.4 mm dia. spec. into the elongated hole to attach the middle thread guide base 0.4 mm dia. spec.

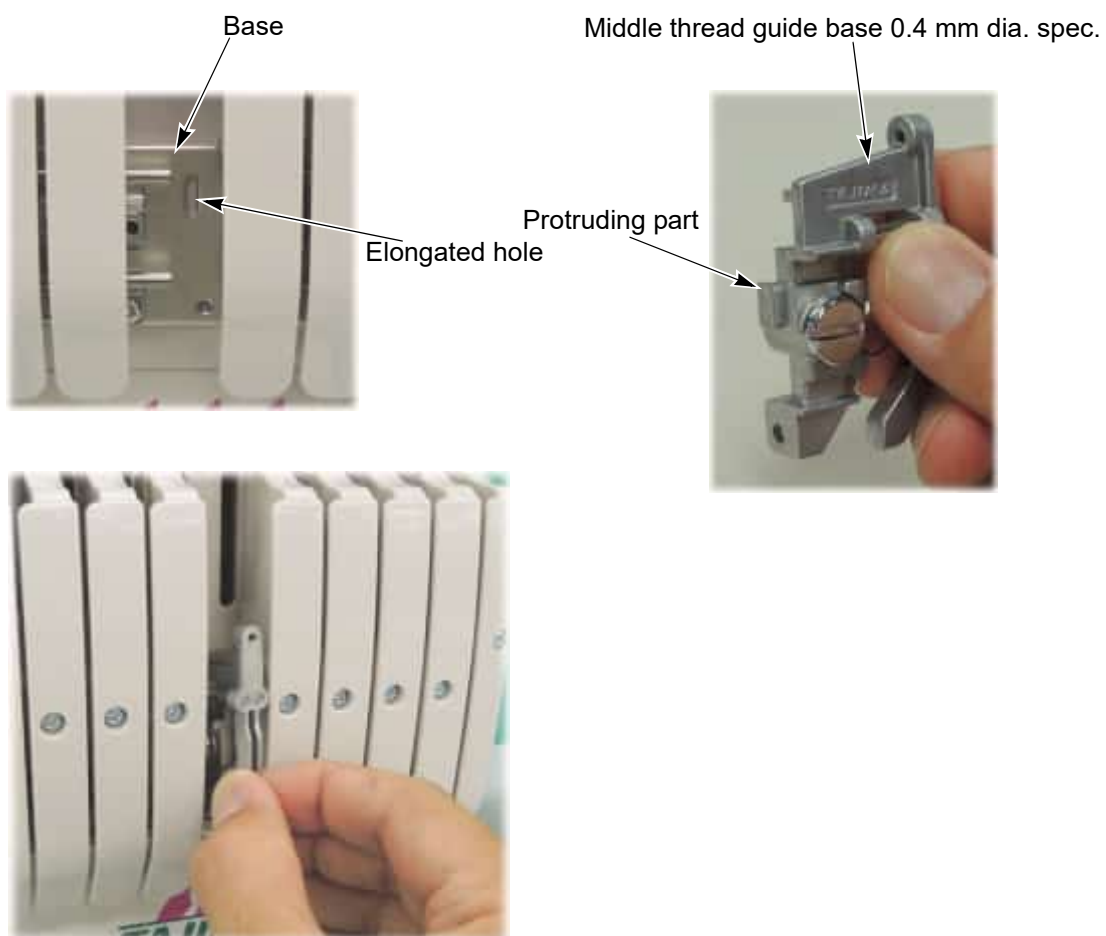

- d. Tighten the screw 2.



e. Insert the pawl of the front face cover into the hole of the top cover.

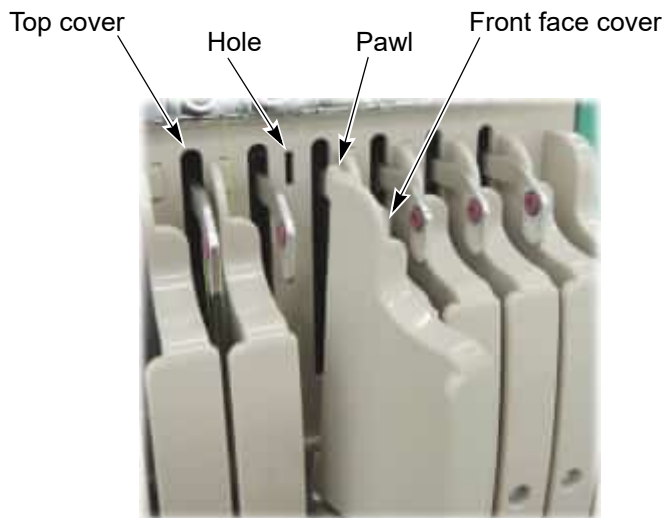

f. Tighten the screw 1.

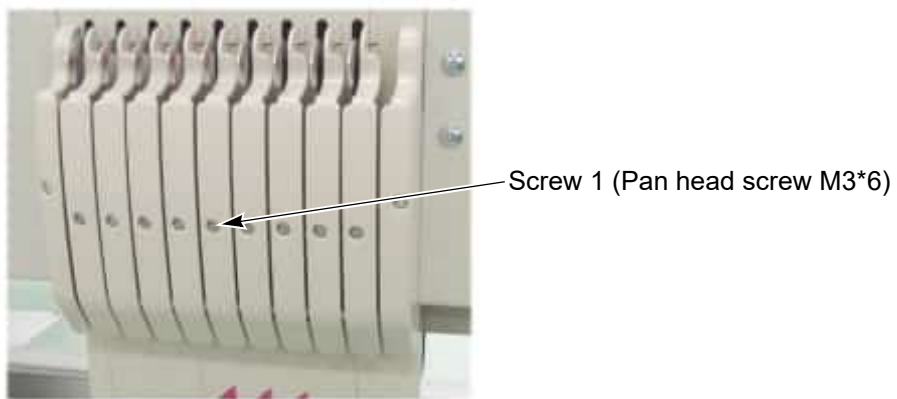

(2) Taper spring

Loosen to detach the tension knurl, and replace 1.0 mm dia. taper spring with 0.6 mm dia. taper spring. Replace the spring of the thread course tension.



(3) Replace the needle.

(4) Replace the needle plate.

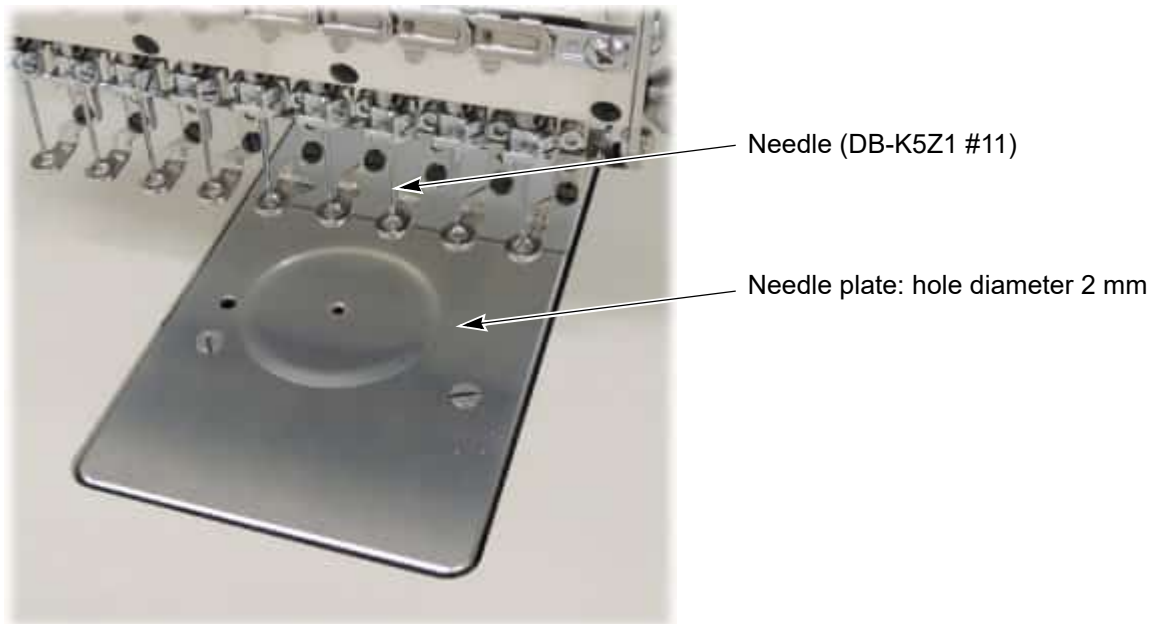

A		Frame Back (to return frame)	112
Air Pressure Sensor	279	Frame Forward (to advance frame)	112
Arbitrary position	256	Frame Type	235
Auto F.B. after T. detection	238		
Auto jump	237	H	
Auto lifting - Sequin device	260	Halt before F.B./inching	239
Auto lubrication system	279		
Auto origin return	252	I	
Auto Start (AS)	233	Insertion of jump at sequin	276
Auto Start after auto data set	234		
Auto start at same color	234	J	
Automatic design rotation (180 deg.)	269	Jump Code Combine	253
Automatic free setting offset	191	Jump Convert	237
Automatic offset	188		
Automatic offset deletion	190	L	
		LAN port	22
B		Language	253
Backlash (X)	267	LED Light	280
Backlash (Y)	267	Low speed r.p.m. / Low speed code r.p.m.	265
Boring device	277	Lubrication cycle	257
Boring step	261	Lubrication cycle (head)	257
C		M	
Condensation sewing	246, 248	M.shaft Inching after ATH	236
Condition data	268	Machine log data download	130
Cording Device	277	Main screen (Screen 1010)	36
		Main Shaft Inching	235
D		Multi Cord Device	278
Data set screen	42	Multi Cord Setting	262
Detailed Network information	262		
E			
Embroidery mode screen (Screen 2000)	47		
F			
F.B./F.F. Stitch unit	238		

N	
Needle Bar Color	256
Needle bar selection screen (Screen 2010)	43
Network	281
Network name	283
O	
Operation panel	20
Operation when power is shut off	122
P	
Picker movement at start of emb.	244
Preset halt (1st before end code)	255
Preset Halt by Data	254
Preset Halt by Designs	254
Preset Halt by Lubrication	255
Preset Halt by stitches	254
Presser foot F.B. lower dead point	242
Presser foot lower dead point	240
Presser foot preset saving screen	41
Presser foot stroke	241
Presser foot stroke mode	242
Presser foot timing	241
R	
R.P.M. limit by needle position	240
Raising and lowering of presser foot	125
Return Stitches	245
Return the frame after manual frame travel	252
S	
Satin Stitch (area)	267
Satin Stitch (density)	268
Satin Stitch (Expansion)	268
Sequential Control Device	280
Sequin device (L)	259, 276
Sequin device (R)	258, 276
Sewing mode screen (Screen 2000)	46
Start/ATH inching r.p.m.	266
Step ratio	251
T	
Table offset position	255
Thread trim length	243
Tie stitches	247
To activate the odd-numbered head or the even-numbered head only	218
To change color	116
To change design name	140
To change direction of sewing design and save it into machine memory	167
To change saving place of design	139
To change the needle bar color	218
To combine design	160
To copy design	158
To create sewing design	175
To decide design to stitch (Data set)	97
To decide using order of needle bars	99
To delete design in machine memory by one design unit	134
To delete design in USB memory	136
To delete minute stitch	147
To delete plural designs in machine memory	135
To delete stitch	145
To delete the needle bar selection setting	211
To divide design	159
To input design in USB memory to machine memory	91
To insert a stitch	143
To insert the new setting in the needle bar selection setting	212
To lower needle bar	123
To lower needle bar to lower dead point	124
To lower/raise the presser foot	125
To make machine memorize frame origin	121

To make new start point	154	Total Stitch Counter	235
To modify a stitch	146	Trace	104
To move frame at position you desire during sewing	191	U	
To move frame automatically at start and end of sewing	188	Under thread detection	250
To move frame to registered position	117, 120	Upgrading of software	323
To move sewing position	156	Upper thread binding at start of emb.	251
To perform Frame Back, Frame Forward (Specification by number of stitches)	113	Upper thread detection	250
To perform Frame Back, Frame Forward (Stop code)	114	Upper thread lock timing	249
To perform test sewing of sewing design	183	USB memory screen (Screen 3100)	39
To raise needle bar	123	USB port	21
To raise/lower all the Sequin devices of all heads at the same time	220		
To raise/lower Sequin devices individually	221		
To repeat embroidery design	206		
To repeat sewing design (Repeat)	197		
To replace Sequin 1 with Sequin 2	222, 224		
To replace specified needle bar No. with other needle bar No. in a batch	217		
To return frame to start position	118		
To reverse embroidery design	205		
To reverse sewing design	196		
To rotate embroidery design	203		
To rotate sewing design	195		
To scale up/down embroidery design	202		
To scale up/down sewing design	194		
To set presser foot in unit of needle bar or step	126		
To sew only desired step by changing setting ...	212		
To sew sewing design and embroidery design in combination	164		
To specify function code and search stitch	142		
To specify stitch No. to search stitch	141		
To switch Frame back, Frame forward	112		
To trim thread	115		
To turn ON/OFF the LED lamp	129		
To write design into a USB memory	137		

1st Edition May, 2015
6th Edition September, 2019

■ **Manufactured by:**
TISM Co.,Ltd.

Address : NO.1800, Ushiyama-cho, Kasugai, Aichi-pref., 486-0901, Japan
TEL : 81-568-33-1161 Fax : 81-568-33-1191

■ **Distributed by:**
Tajima Industries Ltd.

Address : NO.1800, Ushiyama-cho, Kasugai, Aichi-pref., 486-0901, Japan
TEL : 81-568-37-1130 Fax : 81-568-37-1230

●Copy, reprint, or reform of a part or whole of this manual without permission is prohibited.