



USER'S MANUAL

Frame Change

For Golf bag (with table lifter)

TMEZ-SC

Foreword

Thank you for purchasing the TAJIMA embroidery machine.

Please read this manual thoroughly, understand the contents, and then use the machine.

This manual may contain discrepancies in detailed specifications when compared with the actual product. If you have any question, please ask the distributor for information.

Purpose of This Document

This manual and other documents contain the following information. Refer to the necessary documents depending on the application and purpose. The user's manual and other documents are stored as PDF files on the supplied DVD.

■ USER'S MANUAL

For Safe Use

This manual contains instructions on using the machine safely. Make sure to read the manual before use.

Basics

This manual describes the basic knowledge and procedures that are common to all the models and required to use the machine.

If you are a novice to or unfamiliar with the machine, be sure to read this manual first.

Operation

This manual describes the procedures for operating the machine, performing embroidery, and performing maintenance.

Parameter Setting

This manual describes various parameters.

Frame Change (This Document)

This manual describes how to change the frames.

This does not come with some models.

Various Documents

Electrical system diagrams and other technical documents.

■ Other manuals

Quick Guide

This sheet is the Quick reference regarding embroidery methods as well as frequently used functions and their operation procedures.



Keep the Quick Guide handy so that you can reference it quickly.

Optional Device

This manual describes how to set up, operate, and maintain various optional devices.

Safety Precautions and Symbols



Items that require your special attention on handling the machine are specified below.

Description	Meaning
 DANGER	Indicates that there is a lot of danger of death or serious injuries* ¹ .
 WARNING	Indicates that there is a likelihood of death or serious injuries* ¹ .
 CAUTION	Indicates a potentially hazardous situation which may result in minor or moderate injury* ² or physical damage.



*1: A condition caused by electric shock, injury, fracture of a bone etc. that leads to aftereffects, or an injury that necessitates hospitalization or visits to a hospital over a long period.

*2: An injury that does not necessitate hospitalization or visit to a hospital over a long period.

The symbols used throughout this document have the following meanings.

Symbol	Meaning
	Item to be prohibited
	Items that may cause electric shock if not observed
	Items to keep safety

Other Precautions

Description	Meaning
	Items that may affect sewing if not observed.
	Recommended and useful tips.

Disclaimer, etc.

- The external views and specifications of the machine and the contents of this manual are subject to change without notice due to improvement.
- The screen captures and figures contained in this manual may differ depending on the machine specifications, the number of heads or needles, and the presence of optional device.
- TAJIMA bears no responsibility regarding any damage arising from not observing the instructions in the manual or any fault or damage resulting from repair, disassembly, or modification not indicated in the manual.
- You may not copy, reproduce, or transcribe a part or whole of this manual without consent of TAJIMA.

Chapter 1

Golf bag frame

- 1. Attaching golf bag 6
- 2. Changing Frame Type 8

Chapter 2

Border Frame

- 1. Attaching the Border Frame Unit 10
- 2. Changing Frame Type 13
- 3. Setting Fabric 15

Chapter 1

Golf bag frame

1. Attaching golf bag

This section explains how to attach a frame unit after detaching the currently attached frame unit.

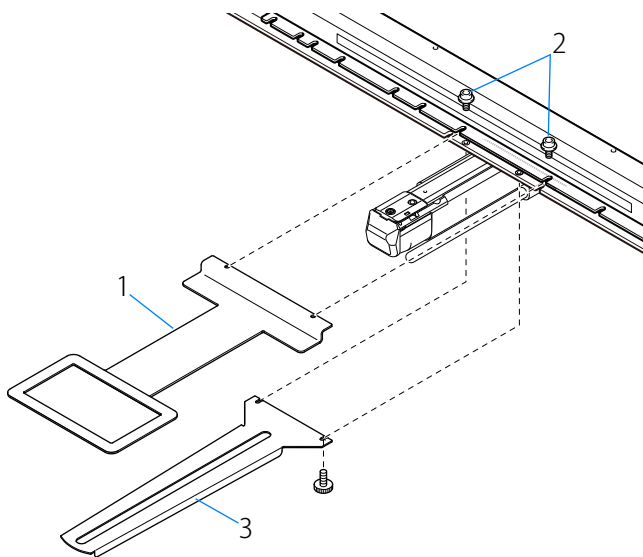

1 Attach golf bag frame 1 by using screw 2.



- There are various types of golf bag frame depending on the embroidery size. For details, please ask the distributor for information.
- Attach the anti-drooping plate 3 when the size of the golf bag frame 1 is large and the head part droops.

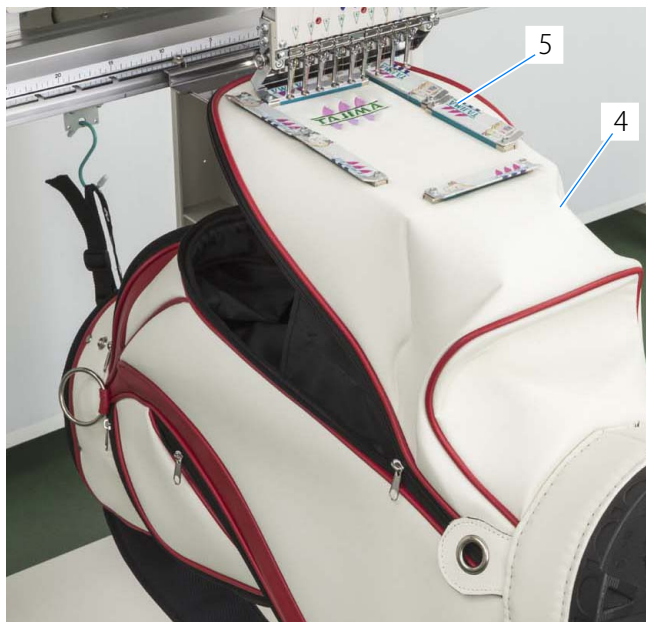

2 Place a golf bag 4 over the golf bag frame and attach it with the magnet 5.

[Example of attaching golf bag]

Photo A



The golf bag is supported by raising the table lifter.

Photo B



The table lifter is not used.
The table lifter is lowered.

Photo B-1 and B-2

The golf bag is hung by using the hook.

Photo B-1

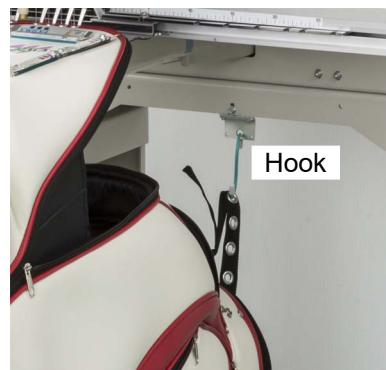

Photo B-2

Photo taken from behind



2. Changing Frame Type

Change drive mode according to the frame type in the case of frame change. Setting cannot be changed during embroidery.

Caution

Do not put your hands on the table when you operate the machine. Failure to observe this may injure your hands or fingers due to the frame travel.

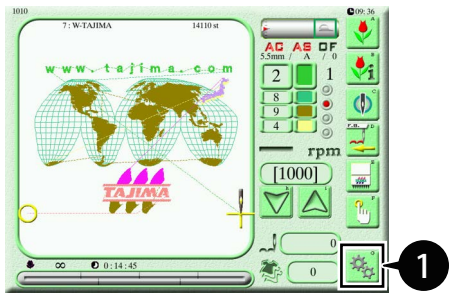

1 Press  on the main screen.

The frame type being set is displayed in the red frame.

 : Border frame

 : Cap frame

 : Tubular goods frame

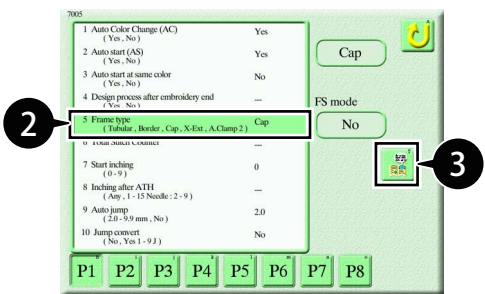

2 Select "5. Frame type".

3 Press .

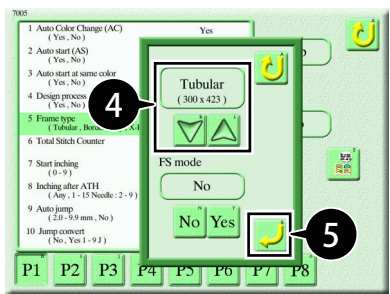

4 Press  and select "Tubular (300X423 or 379X525)".



- Set the software frame limit according to the size of golf bag frame.
- Select "Yes" if FS mode is necessary.

Press .

The frame type will be changed.



- The data set will be canceled when the frame type is changed.

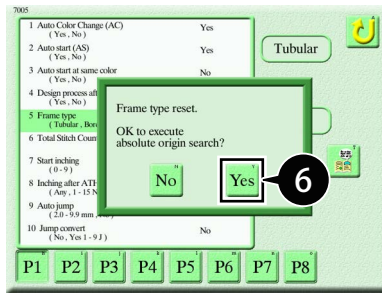

5 Press **Yes**.

The frame will move to the absolute origin and return to the original position.



- The embroidery space changes when the frame type is changed. Therefore, perform an absolute origin search.

Chapter 2

Border Frame

1. Attaching the Border Frame Unit

This section explains how to attach a frame unit after detaching the currently attached frame unit.

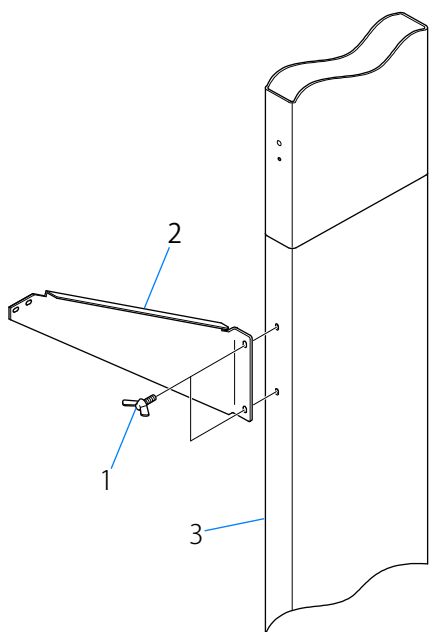

- 1 Attach the table bracket 2 to the stand 3 by using the wing bolt 1.



- This explanation shows how to attach to the right side. Parts are also attached to the left side in the same way.

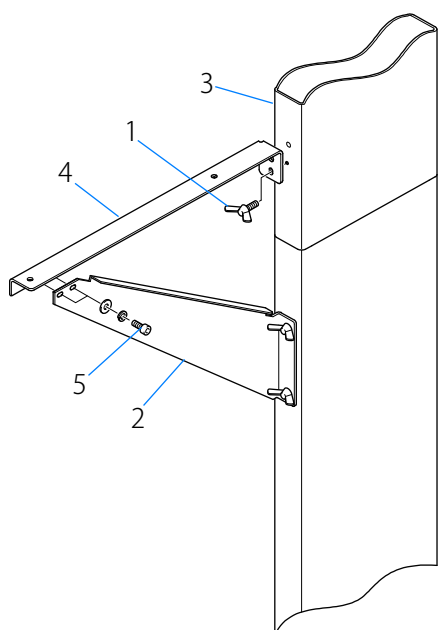

- 2 Attach the table support base 4 to the stand 3 by using the wing bolt 1.
- 3 Attach the table support base 4 to the table bracket 2 by using the screw 5.

- 4** Attach the table 6 to the table support base 4 by using wing bolts 1.

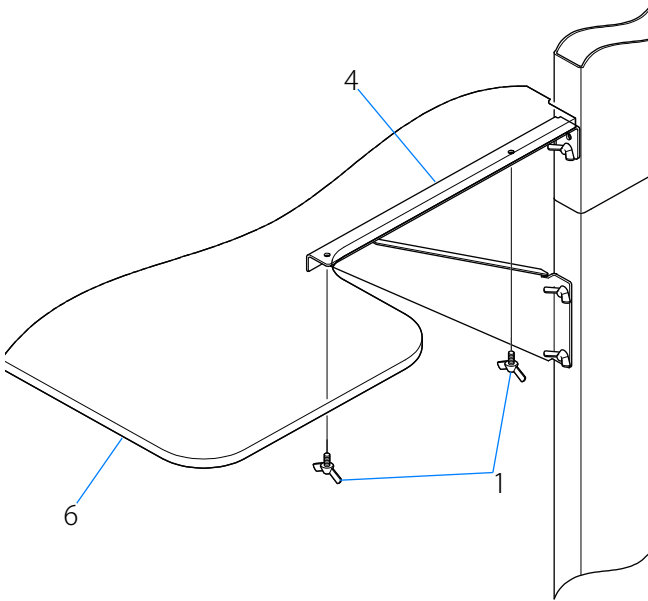

- 5** Detach the box cover 7.

- 6** Attach the screw 8 to the stand 3.

Head part (tip) of the screw 8 is for positioning the table support base 4. At this time, attach the screw 8 to any position.

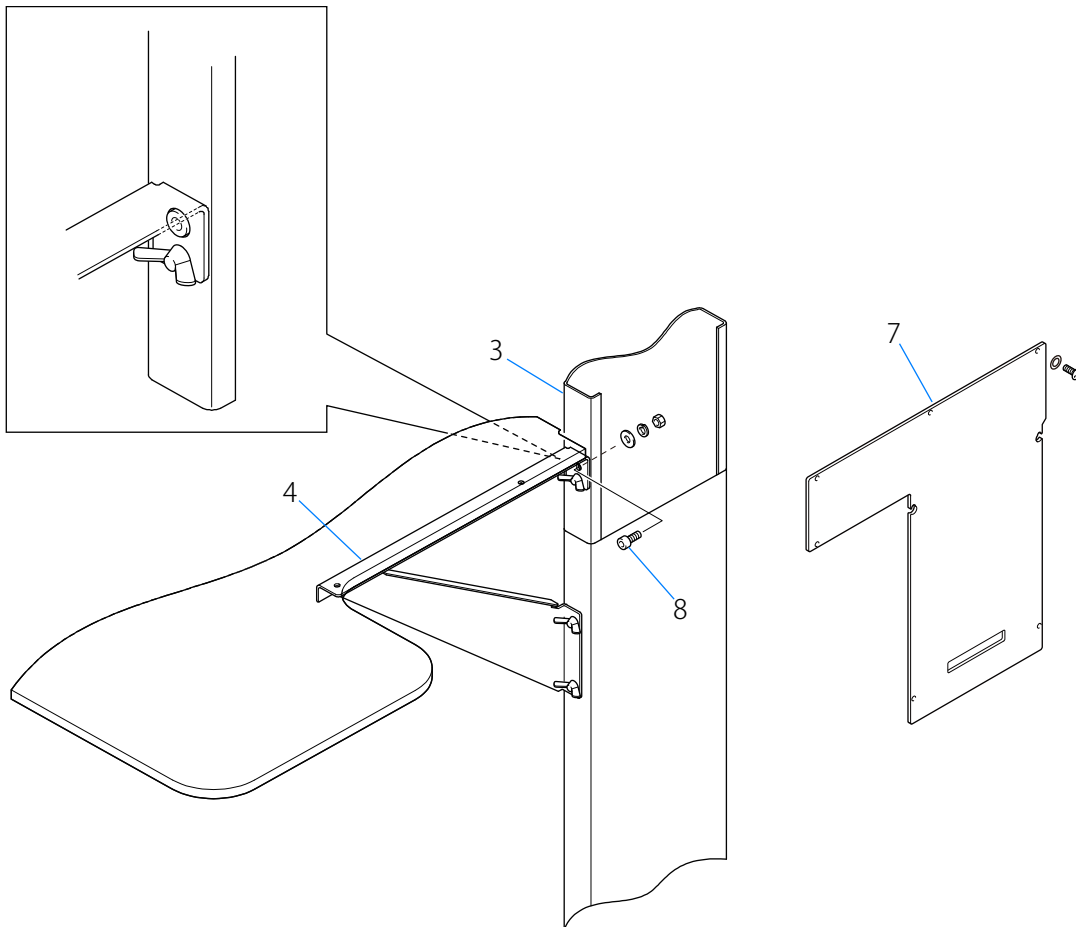

1. Attaching the Border Frame Unit

- 7** Check if the upper surface 9 of the table almost align with the upper surface 10 of the needle plate. When there is difference of 0.5 mm or more, loosen the screw 8 and wing bolts 1 to adjust the height of the table 6.

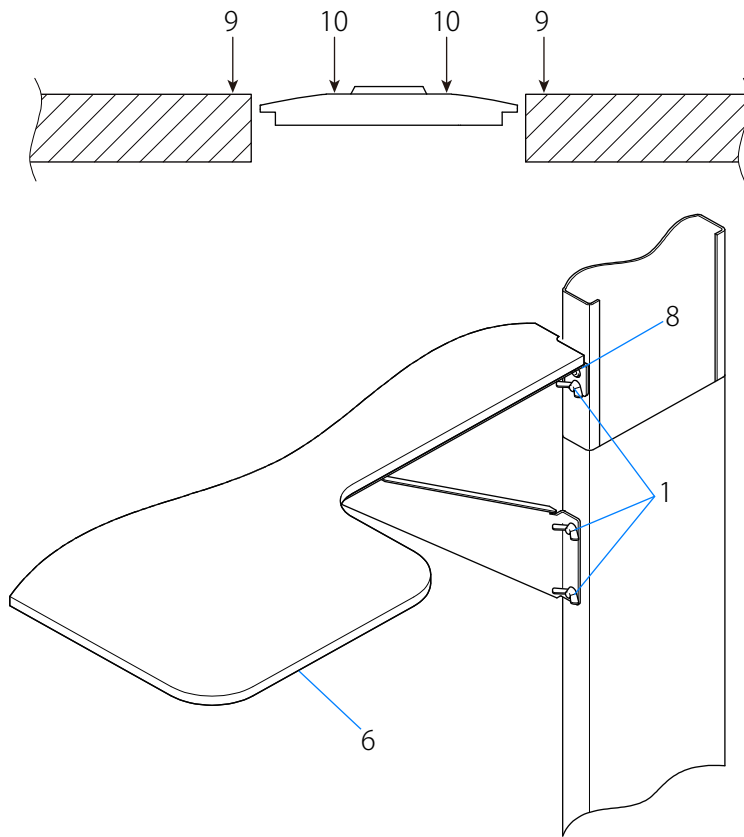

- 8** Attach the border frame 11 using screws 12.

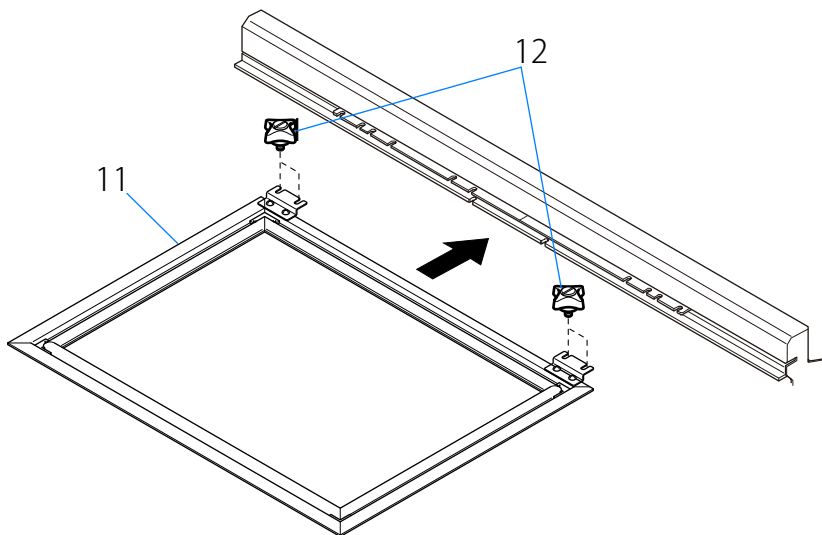

2. Changing Frame Type

Change drive mode according to the frame type in the case of frame change. Setting cannot be changed during embroidery. Contents of display differ depending on model.

⚠ Caution

- ⊘ Do not put your hands on the table when you operate the machine. Failure to observe this may injure your hands or fingers due to the frame travel.

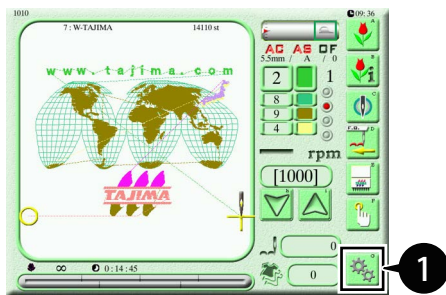

- 1 Press  on the main screen.

The frame type being set is displayed in the red frame.



: Border frame



: Cap frame



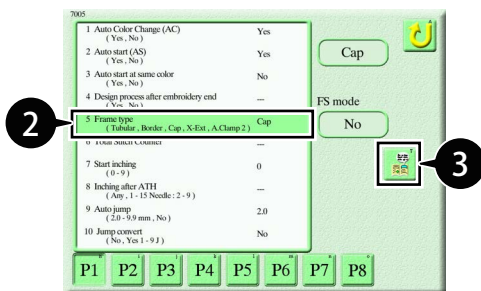

: Tubular goods frame

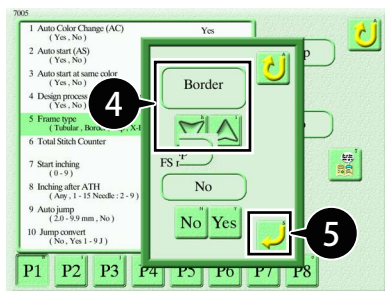

- 2 Select "5. Frame type".

- 3 Press .



- 4 Press  and select "Border".



- Select "Yes" if FS mode is necessary.

- 5 Press .

The frame type will be changed.



- The data set will be canceled when the frame type is changed.

2. Changing Frame Type

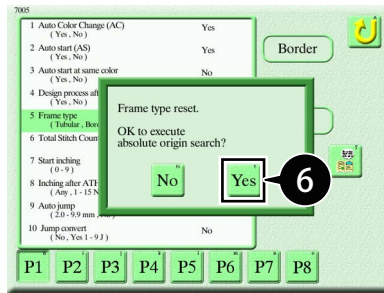

6 Press **Yes**.

The frame will move to the absolute origin and return to the original position.



- The embroidery space changes when the frame type is changed. Therefore, perform an absolute origin search.

3. Setting Fabric

Set the fabric to the border frame and fit clips.

There are various clip sizes varying with the length. Arrange these clips so that the fabric is fixed equally.



- For how to stretch the fabric, refer to the separate manual "BASICS".

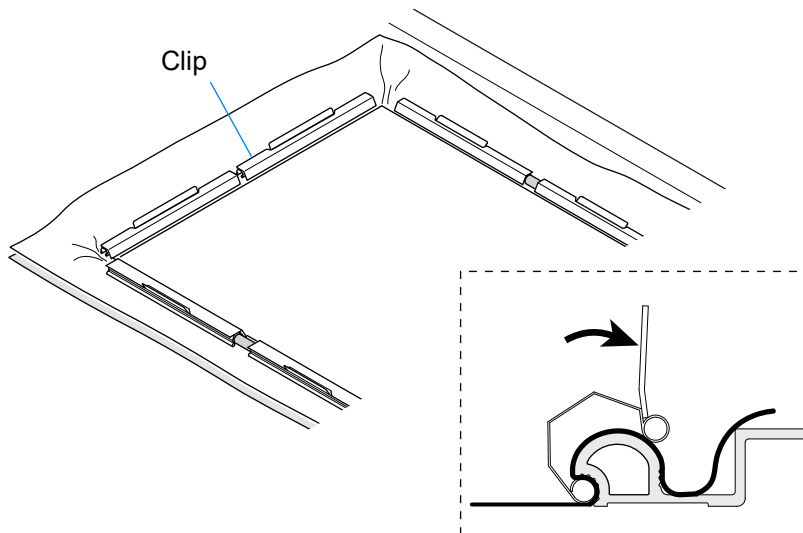

■ **Manufactured by:**
TISM Co.,Ltd.

Address : NO.1800, Ushiyama-cho, Kasugai, Aichi-pref., 486-0901, Japan
TEL : 81-568-33-1161 Fax : 81-568-33-1191

■ **Distributed by:**
Tajima Industries Ltd.

Address : NO.1800, Ushiyama-cho, Kasugai, Aichi-pref., 486-0901, Japan
TEL : 81-568-37-1130 Fax : 81-568-37-1230

●**Copy, reprint, or reform of a part or whole of this manual without permission is prohibited.**