

USER'S MANUAL
FRAME REPLACEMENT
TFMX-IIC TYPE-2



Foreword

This user's manual describes about the correct using method and instructions for use of this product. Please use this machine after understanding the contents of the manual.

This manual may contain discrepancies in detailed specification as compared with the actual production. If you have any question about this manual, consult your TAJIMA distributor.

We believe that "BASICS TAJIMA EMBROIDERY MACHINES" and "MACHINE SETUP INSTRUCTIONS" are useful to deepen your knowledge about this product. Please also read those booklets.

Regarding how to handle the products related, refer to the user's manual exclusive for them included in the manual CD.

TISM Co.,Ltd.

SAFETY PRECAUTIONS

To prevent any harm or damage to the person who use this product or other person, we describe items that must be surely followed as below.



Indicates that there is a lot of danger of death or serious injuries [*1] if handled by mistake.



Indicates that there is a likelihood of death or serious injuries [*1] if handled by mistake.





Indicates a potentially hazardous situation which may result in minor or moderate injury [*2] or property damage if handled by mistake.

*1: A condition caused by electric shock, injury, fracture of a bone, etc., that leads to aftereffects, or an injury that necessitates hospitalization or visits to a hospital over a long period.

*2: An injury that does not necessitate hospitalization or visit to a hospital over a long period.

 : Prohibited items

 : Items that may cause electric shock if not observed

 : Items that must be followed carefully to ensure safe operation

About the label (accessory)

The label is used to distinguish the center of embroidery space of each frame type. Attach the label according to need of the frame you use.

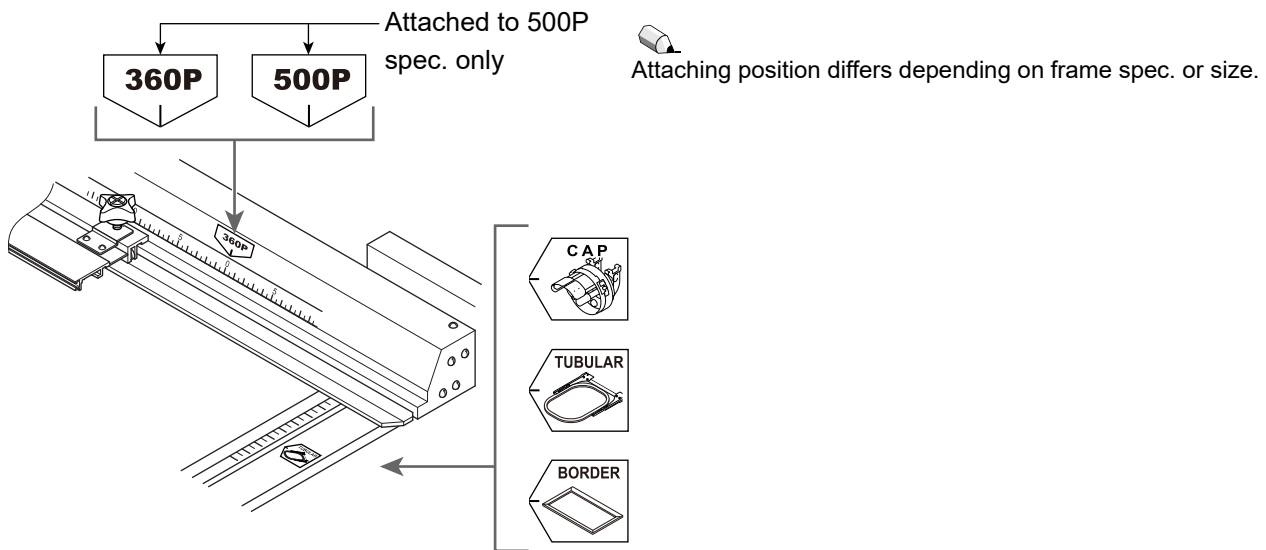

Chapter 1 Cap frame 2

1. To detach frame unit.....	1
1-1. Tubular goods frame	1
1-2. Border frame	2
2. To change the height of table	3
3. To attach cap frame unit.....	5
4. To change frame type.....	8
5. To set material	10

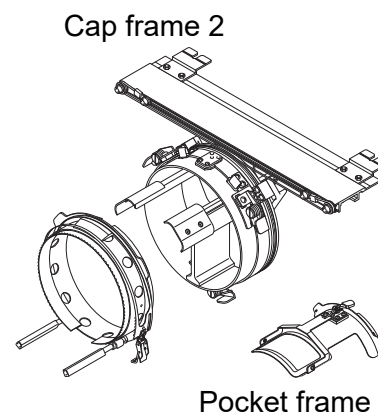

Chapter 2 Tubular goods frame

1. To detach frame unit.....	15
1-1. Cap frame	15
1-2. Border frame	16
2. To change the height of table	17
3. To attach tubular goods frame unit.....	19
4. To change frame type.....	20
5. To set material	22

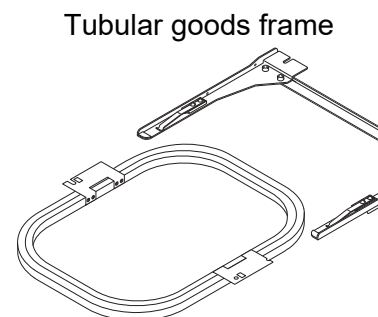

Chapter 3 Border frame

1. To detach frame unit.....	24
1-1. Tubular goods frame	24
1-2. Cap frame	25
2. To change the height of table	26
3. Attaching the border frame unit	28
4. To change frame type.....	29
5. To set material	31
5-1. 2-head machine, 360P or less of 4-head machine.....	31
5-2. 500P or more of 4-head machine, 6-head machine, 8-head machine	

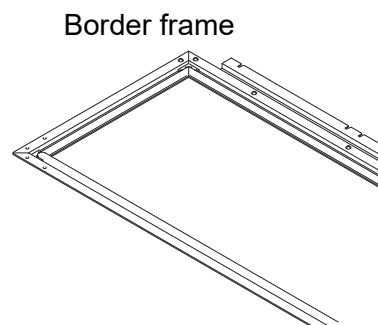

Chapter 4 Adjustment and maintenance

1. To attach the drive ring shaft	33
2. To adjust the position of cap frame unit	34
3. To adjust the tension of drive wire.....	35
4. Periodic inspection	39

Chapter 1 Cap frame 2

"Cap frame 2" is described as "Cap frame" in this manual for convenience.

Also for the pocket frame, perform working according to this chapter.

CAUTION

! [*] Perform the contents described in this chapter with power OFF or sleep mode. Otherwise, you could be injured by unexpected malfunctioning of the machine.

* How to switch to sleep mode



Press the sleep mode key for a few seconds in the state of the main screen. To release, press this key for a few seconds. After that, press [SET] according to the message to be displayed.



It is possible to move the frame by hand during sleep mode, but it is not possible to operate the machine.

1. To detach frame unit

1-1. Tubular goods frame

(1) Loosen screws 1 to detach the frame holder 2.

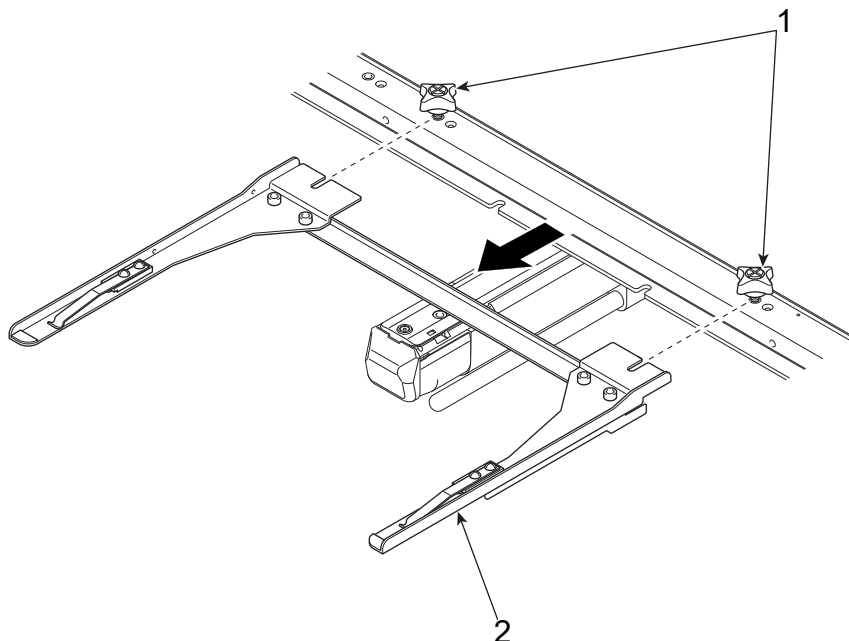

(2) After that, perform the following work.

"2.To change the height of table" (→P.3)

1-2. Border frame

(1) Loosen screws 1 to detach the border frame 2.

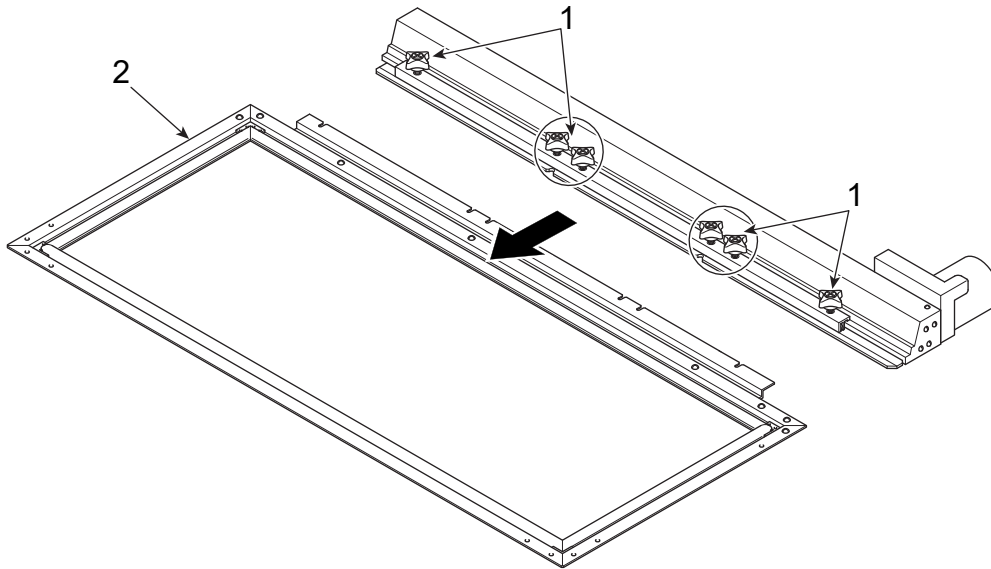

(2) After that, perform the following work.

"2.To change the height of table" (→P.3)

2. To change the height of table

(1) Release all toggle clamps 1 positioned at the bottom of the table.

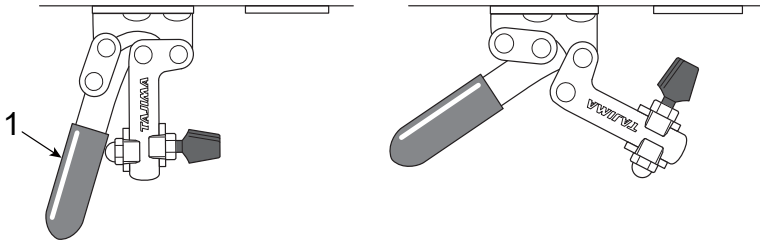

(2) Remove the screw 2 of the stay 1 under the table.

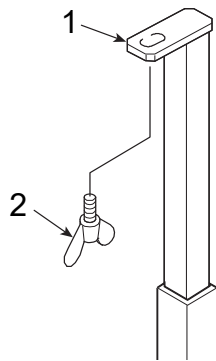

(3) Detach the table 1.

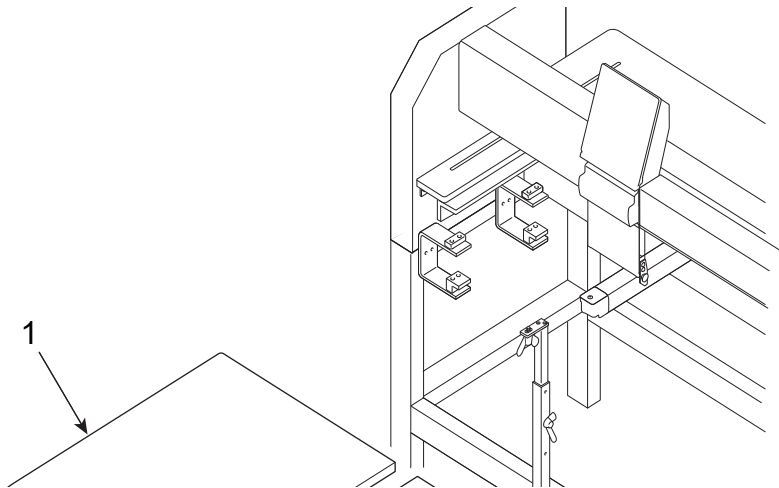

- (4) Detach the screw 1, and tighten the screw 1 after adjusting the height of the stay 2 to the frame type.

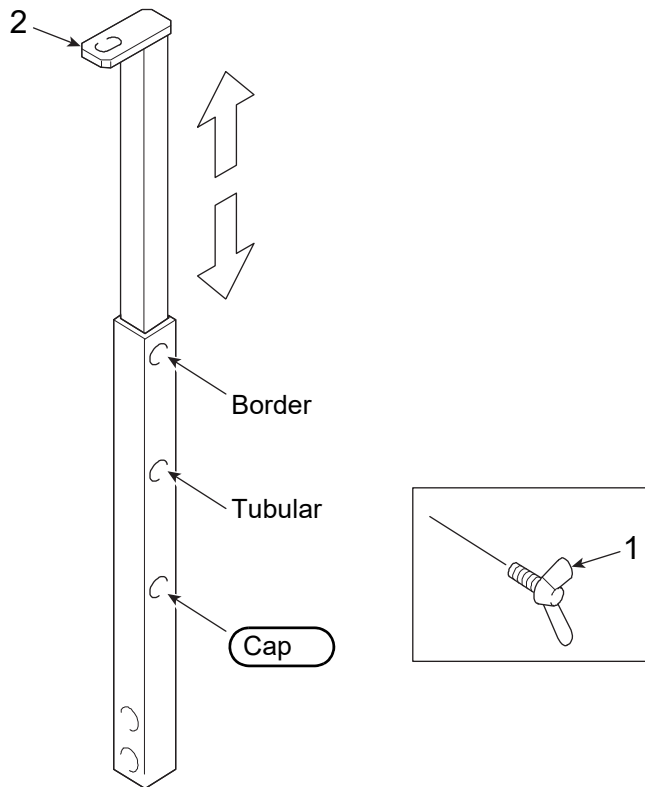

- (5) Place the table 2 on the table holder 1 corresponding to the type of frame, and push it to the back firmly. Then tighten the screw 3.

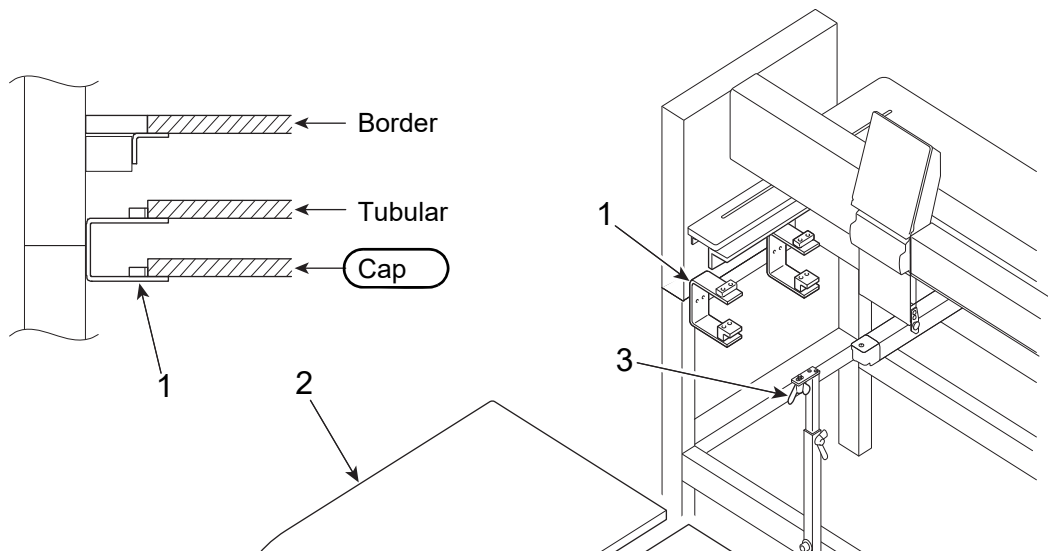

- (6) Fix all toggle clamps 1.

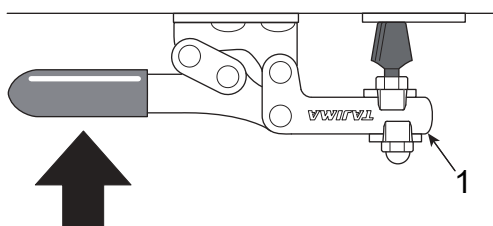

3. To attach cap frame unit

 Attach the cap frame unit even if you use a pocket frame.

- (1)** Move the frame in right/left direction to align the right end 1 of the slide base with the scale (chart below) of the scale sheet 2.

Frame Spec.	Scale
360P	0
500P	7

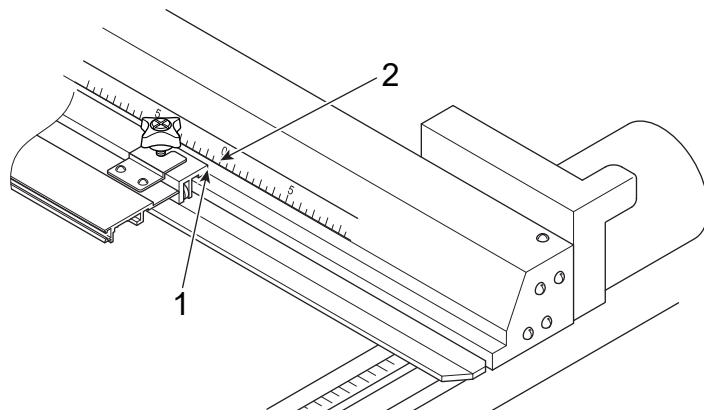

- (2)** Fit the cap frame unit 1 into the drive ring shaft 2.

 When the drive ring shaft is not installed, perform the following work.
"To attach the drive ring shaft" (→P.33)

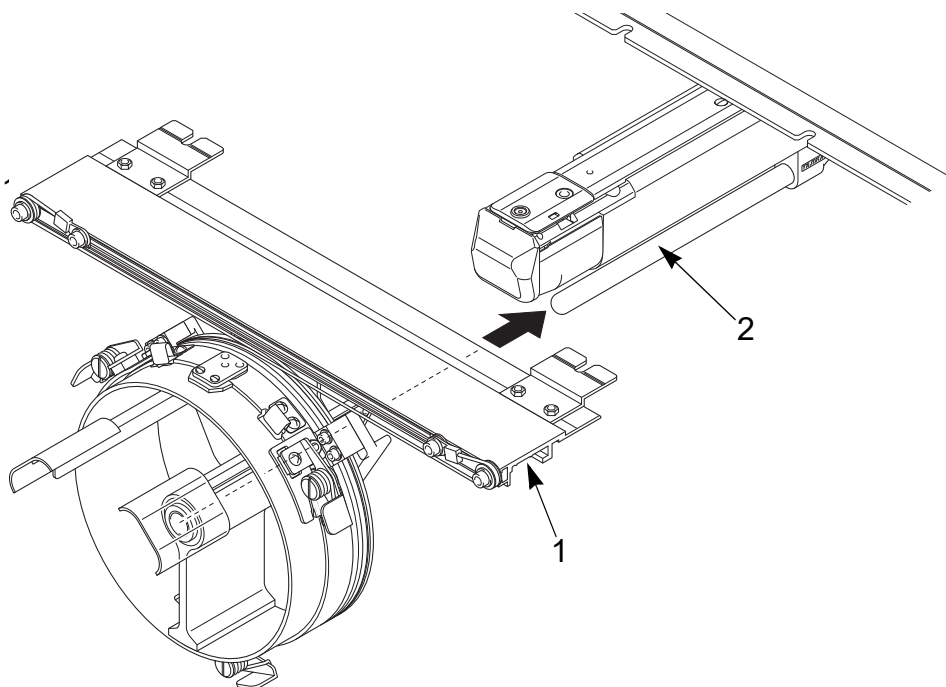

(3) Connect the cap frame unit 3 and drive section 4 by using the screws 1 and 2.

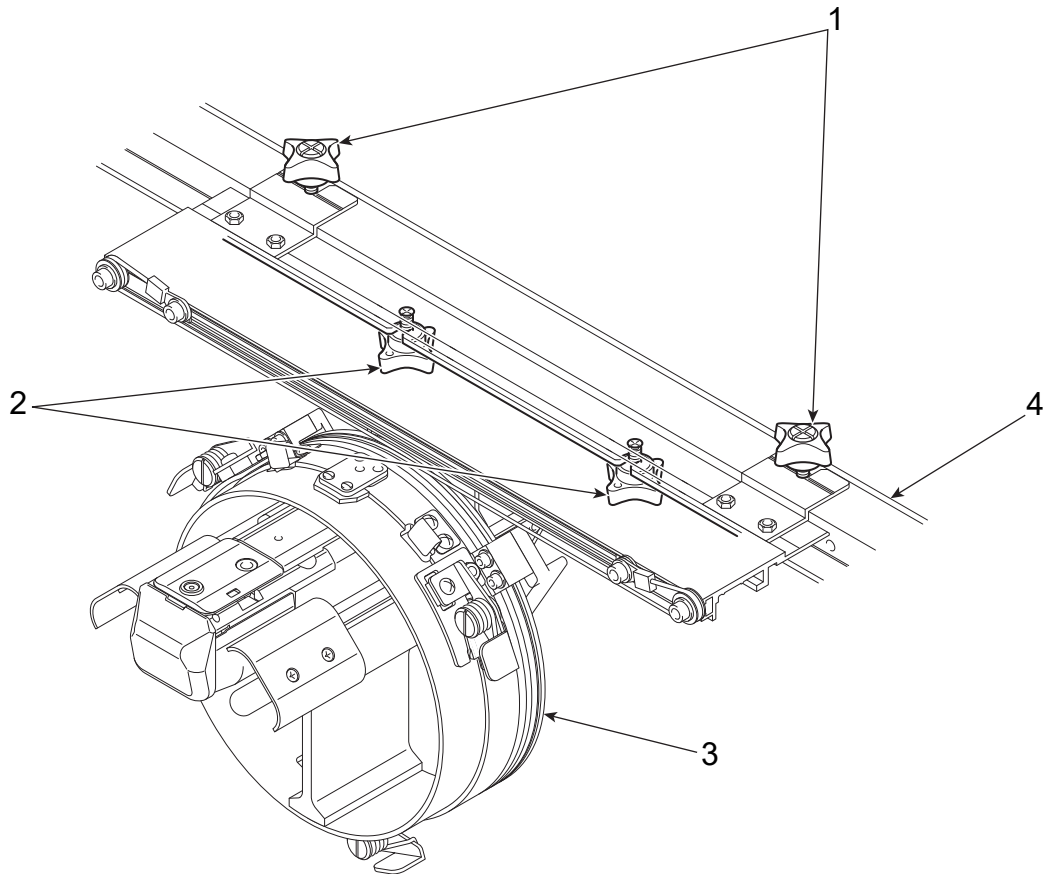

🔧 Attach the pocket frame 1 to the drive ring 3 after detaching the needle plate bracket 2.

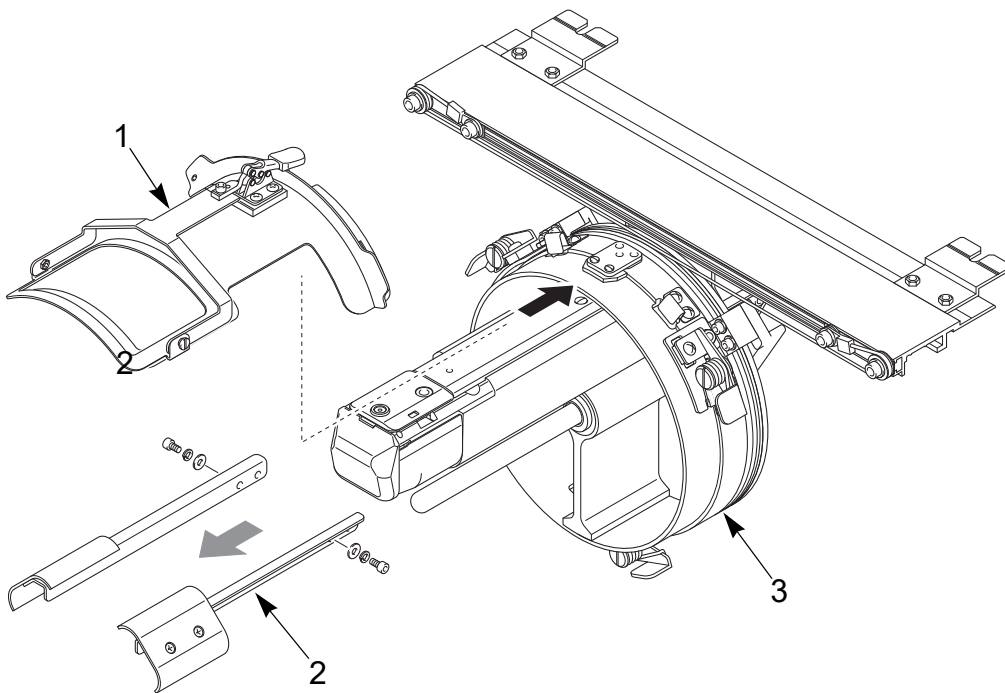

(4) Detach the hook cover 2 by loosening screws 1, and attach the cap frame guide 4 by tightening screws 3.

 It is not necessary to detach the cap frame guide 4. However, only when embroidery working has a trouble, replace it with the hook cover 2.

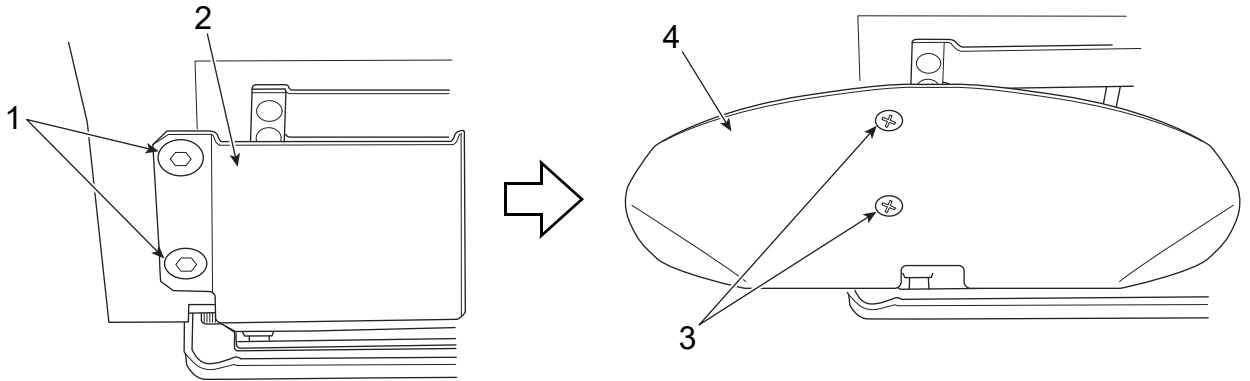

4. To change frame type

After replacing the frame, change the frame type according to the following procedure. It is not possible to change while embroidering.

(1) Screen

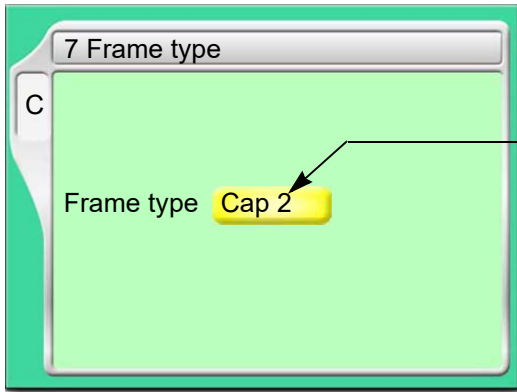

Select the frame.

For TFMX-IIC TYPE-2, select "Cap 2".

For the pocket frame, select "Tubular".

(2) How to operate

CAUTION

 When performing this operation, do not put your hands, etc. on the table. Moving the frame could injure you.

[a] To open screen

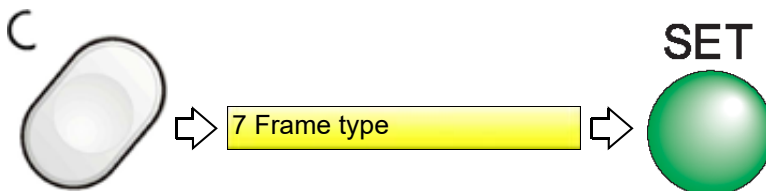

[b] To select the frame



[c] Execute Frame Origin Memory.

The message below is displayed only when "Frame origin memory with the Power-ON" ([SET]+F1-7) is set to YES.

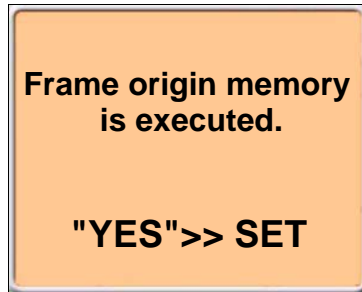

Pressing SET key will move the frame.

5. To set material

(1) Push the cap frame 1 until it is fixed by the lock pin 3 of the setting frame 2.

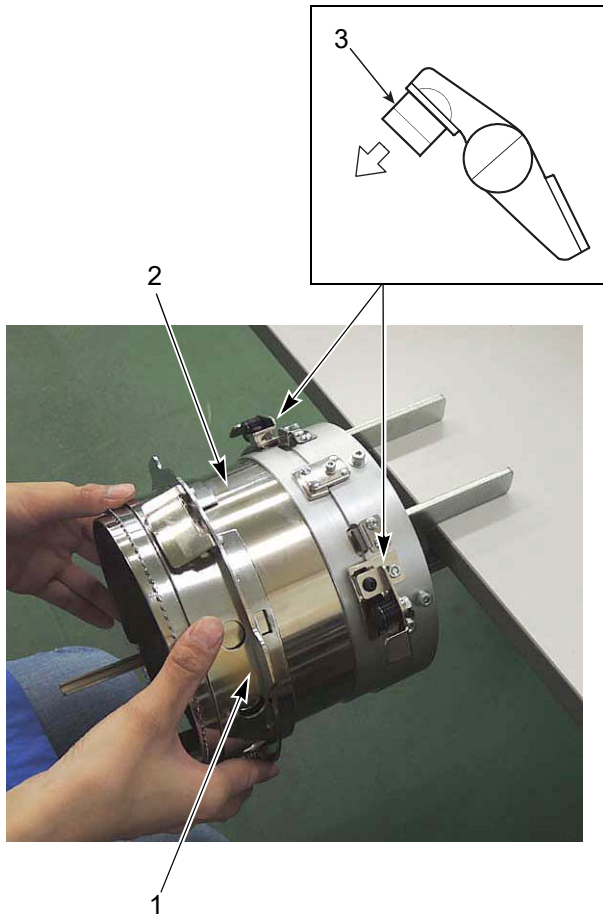

To detach the cap frame 1 from the setting frame 2, push the attach/detach lever 4 in left and right to detach the lock pin 3.

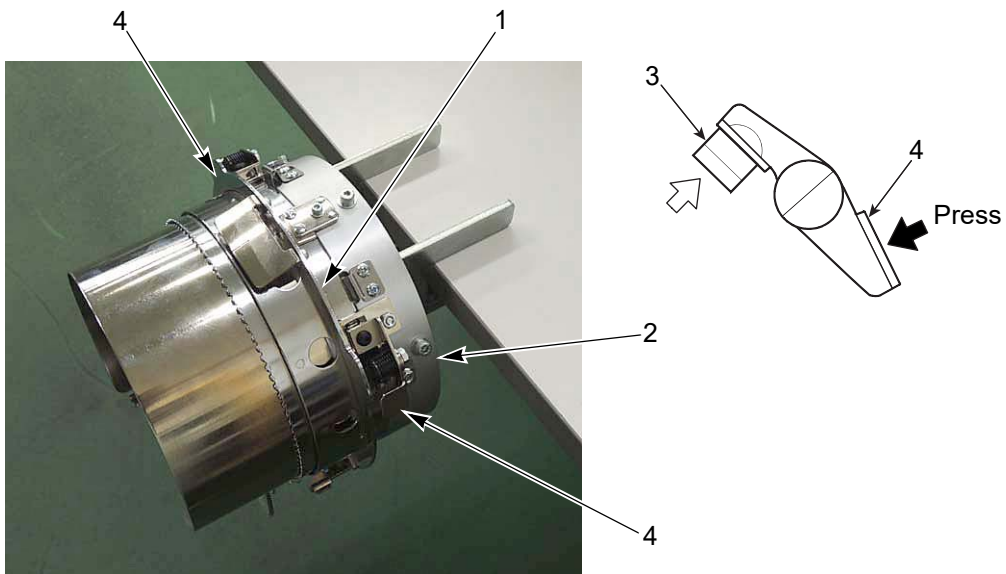

(2) Set the interlining cloth 1 to the cap frame 2.

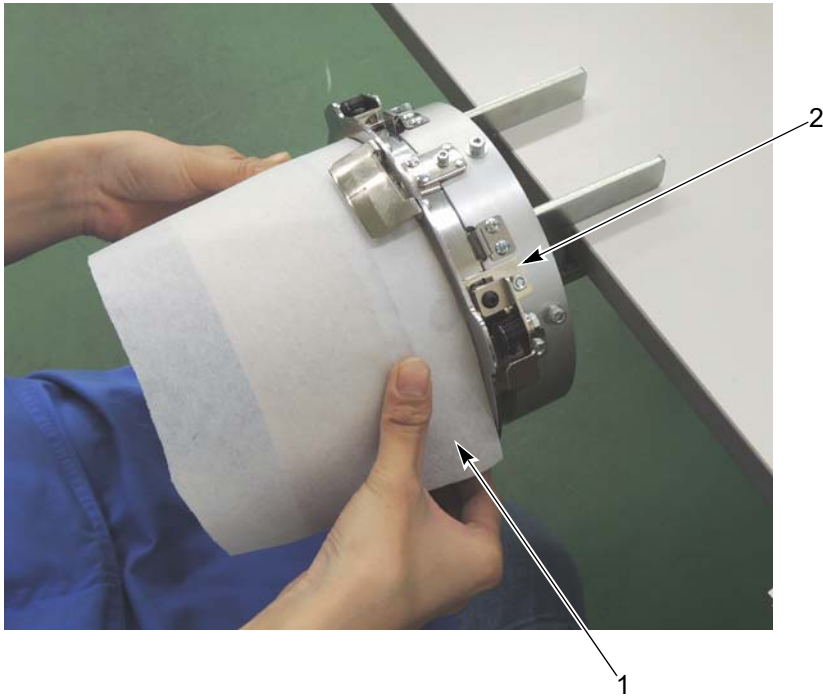

(3) Align the center of cap with the mark-off line 2 so that the visor 1 of cap comes directly above, and pull the sweatband 3 outside, and clip between the holder 4 and the interlining cloth 5.

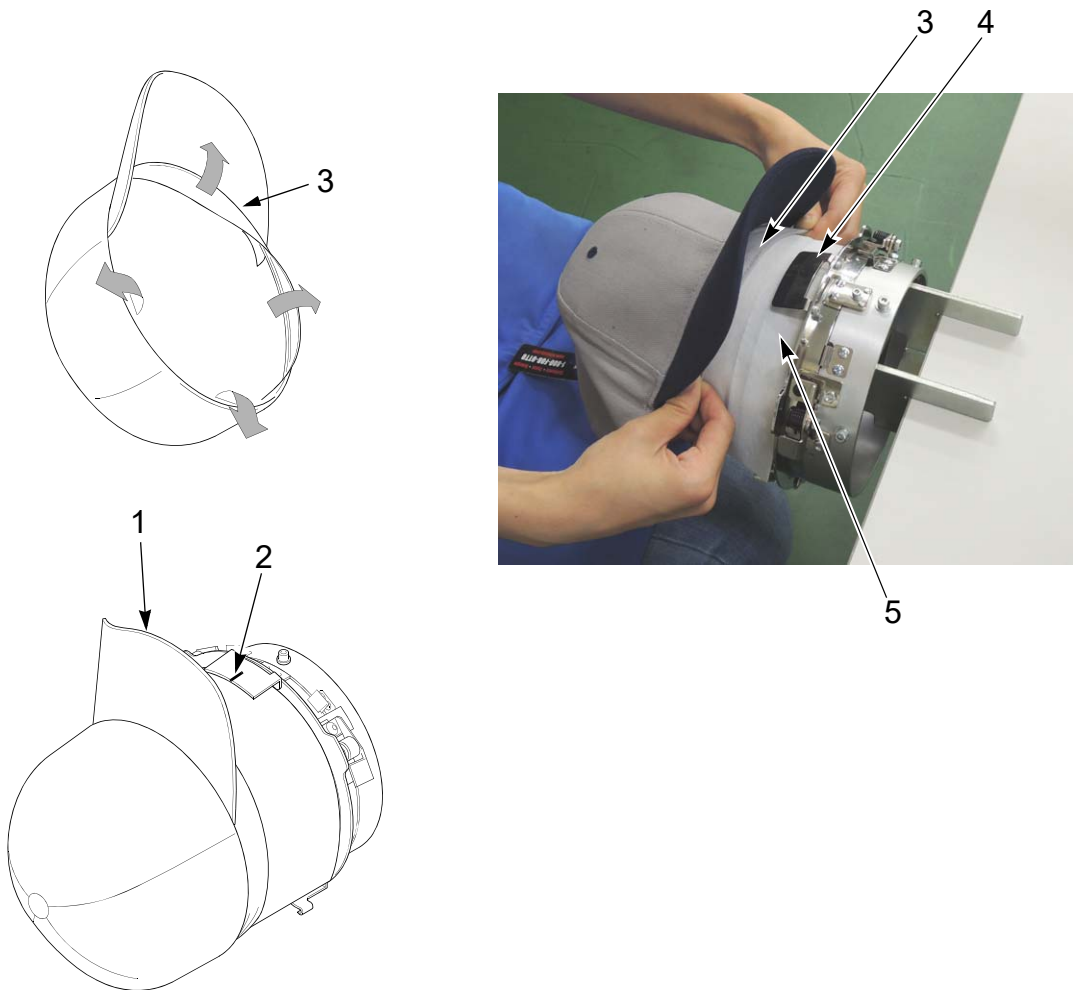

(4) Close the lid frame 1 and fix the cap by the lock 2.

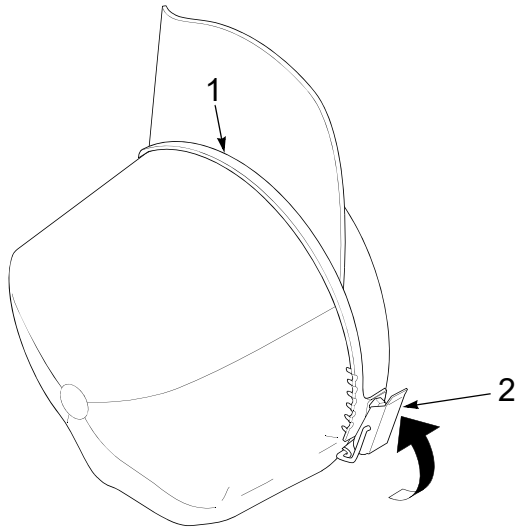
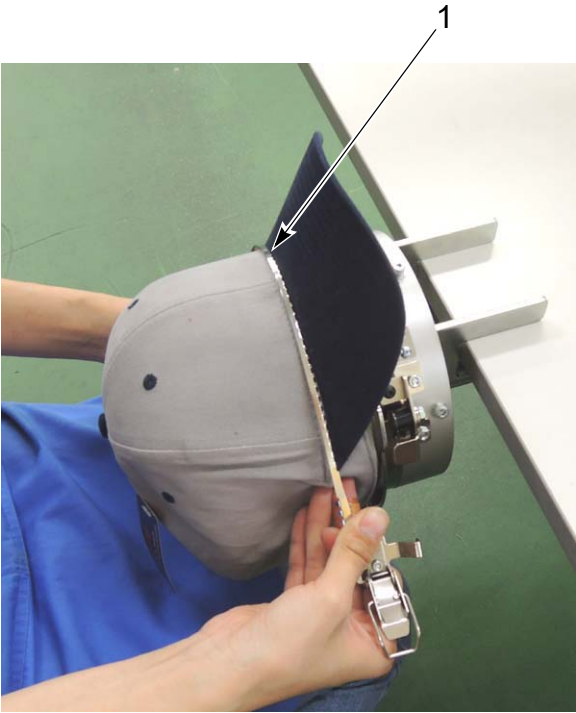

When the fabric thickness of cap is changed, loosen the screw 1. Then, adjust the position of the lid frame holder 2 in accordance with the fabric thickness of cap.

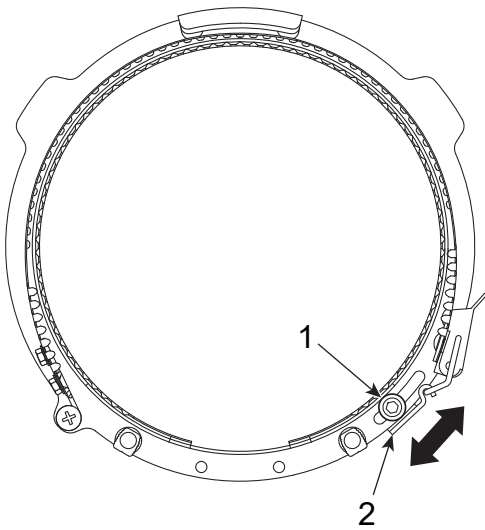

- (5)** Push the attach/detach lever 1 in left and right to detach the cap frame 2 from the setting frame 3. Stretch the fabric insofar as roundness of the cap does not disappear, then fix the cap by using clips 4.

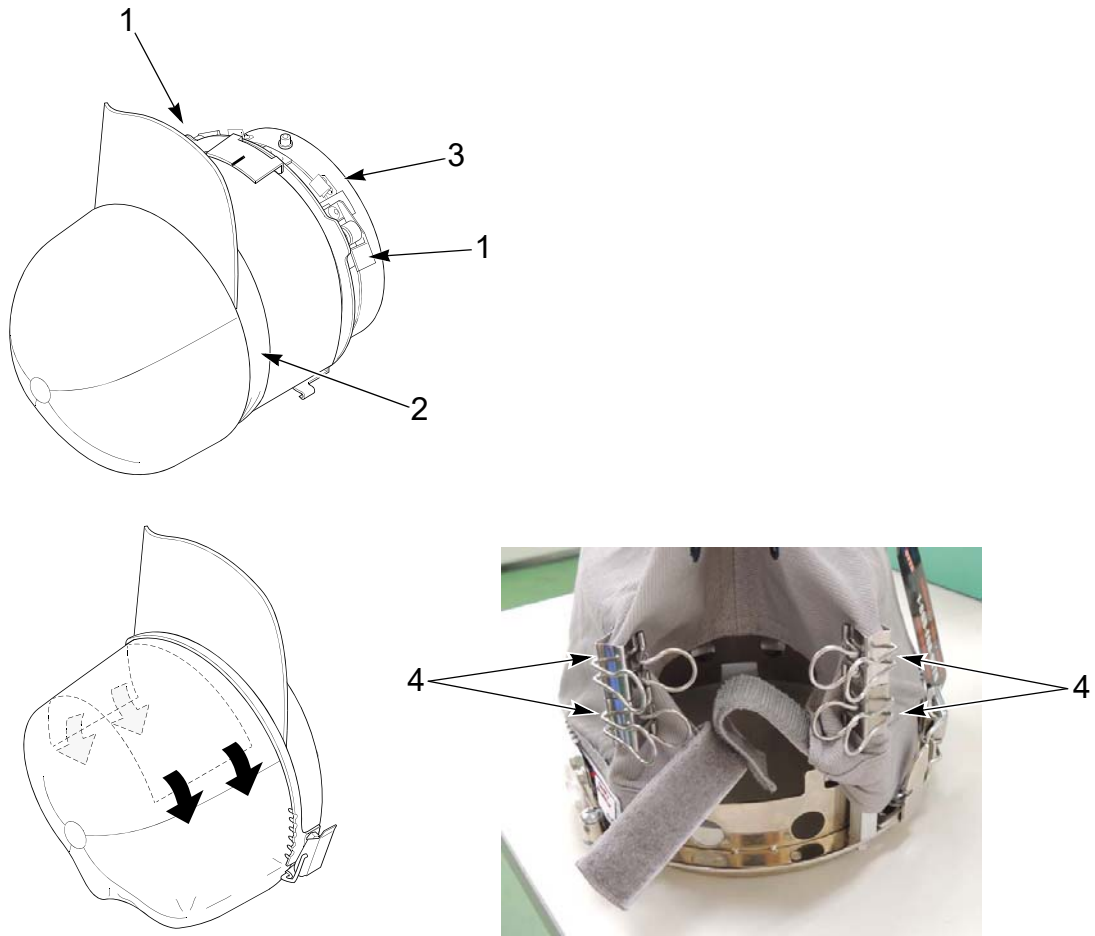

- (6)** Push the cap frame 1 until it is locked by the lock pin 2.

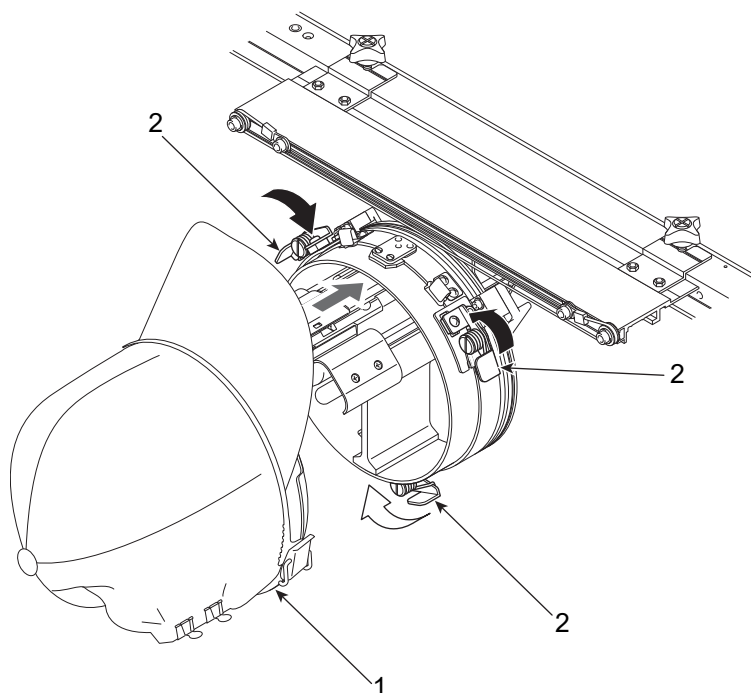

-  To prevent the presser foot 1 from hitting the lid frame 2 when embroidering, make a distance 15 mm or more at section A in the figure below.

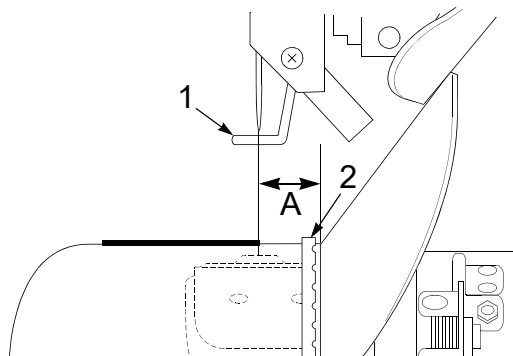

-  When the cap depth 1 is changed, change the attaching position of the needle plate guide 2.

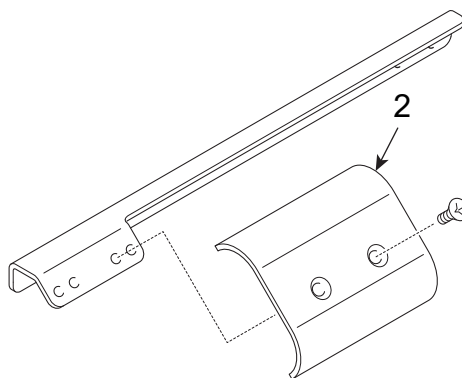
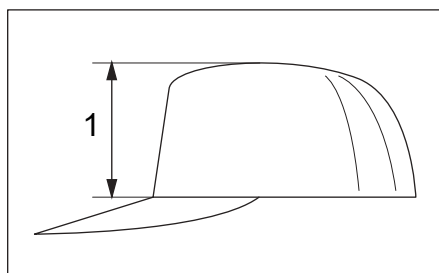

The replacement to the cap frame (including the pocket frame) and the setting procedure of the material are completed now.

Chapter 2 Tubular goods frame

CAUTION

 [*] Perform the contents described in this chapter with power OFF or sleep mode. Otherwise, you could be injured by unexpected malfunctioning of the machine.

* How to switch to sleep mode



Press the sleep mode key for a few seconds in the state of the main screen. To release, press this key for a few seconds. After that, press [SET] according to the message to be displayed.



It is possible to move the frame by hand during sleep mode, but it is not possible to operate the machine.

1. To detach frame unit

1-1. Cap frame

(1) Loosen screws 1 and 2 to detach the cap frame unit 3.

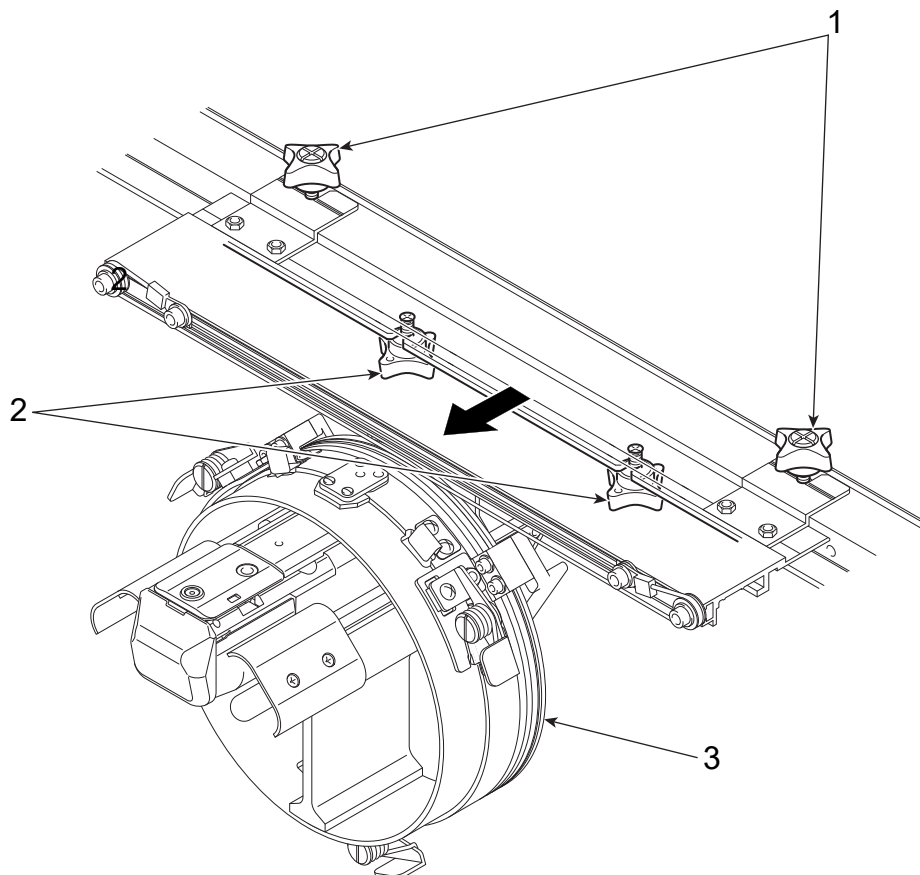

(2) After that, perform the following work.

"2.To change the height of table" (→P.17)

1-2. Border frame

(1) Loosen screws 1 to detach the border frame 2.

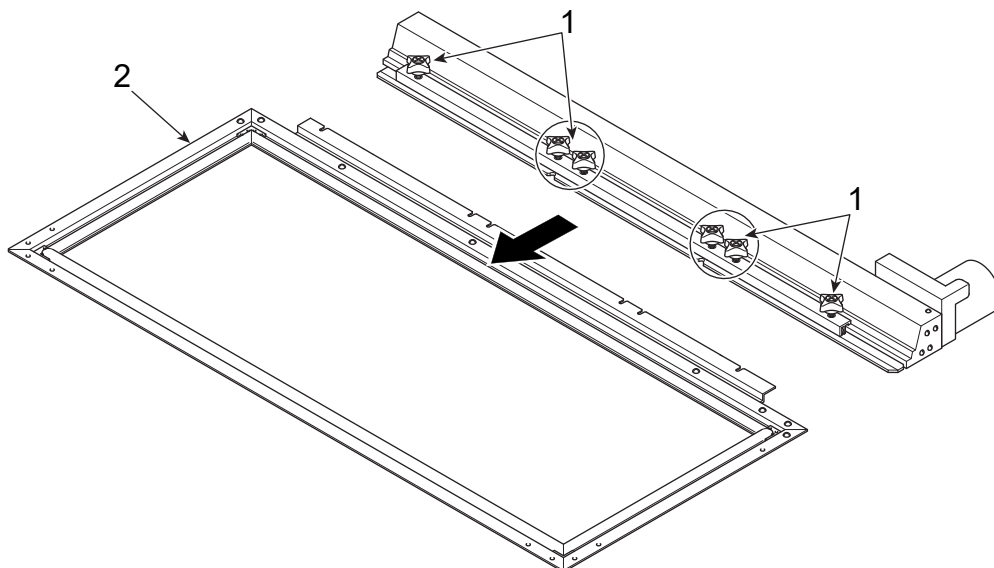

(2) After that, perform the following work.

"2.To change the height of table" (→P.17)

2. To change the height of table

(1) Release all toggle clamps 1 positioned at the bottom of the table.

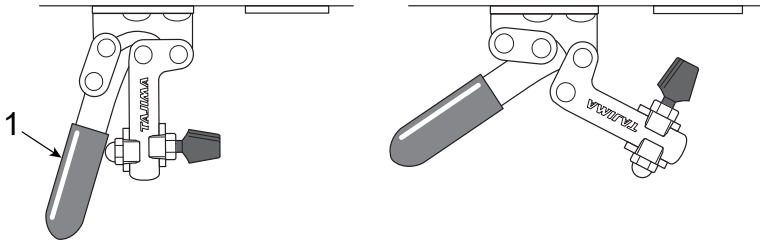

(2) Remove the screw 2 of the stay 1 under the table.

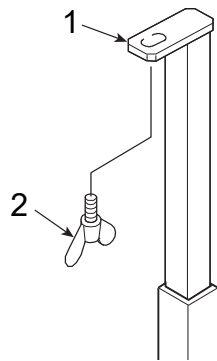

(3) Detach the table 1.

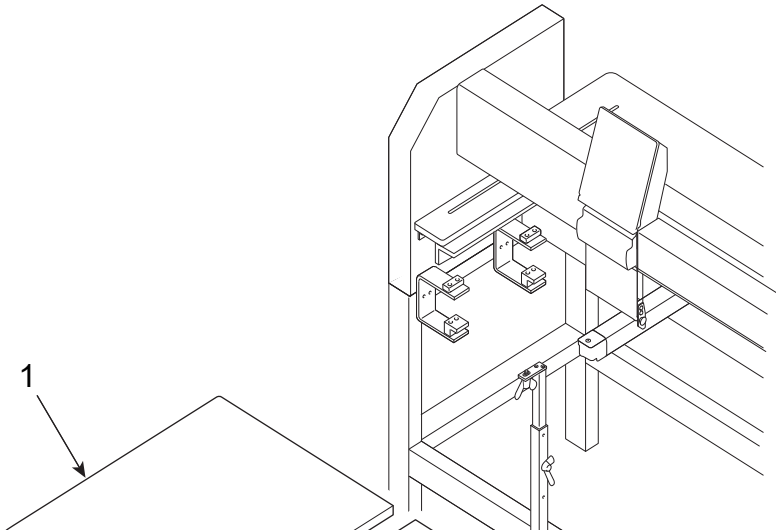

(4) Detach the screw 1, and tighten the screw 1 after adjusting the height of the stay 2 to the frame type.

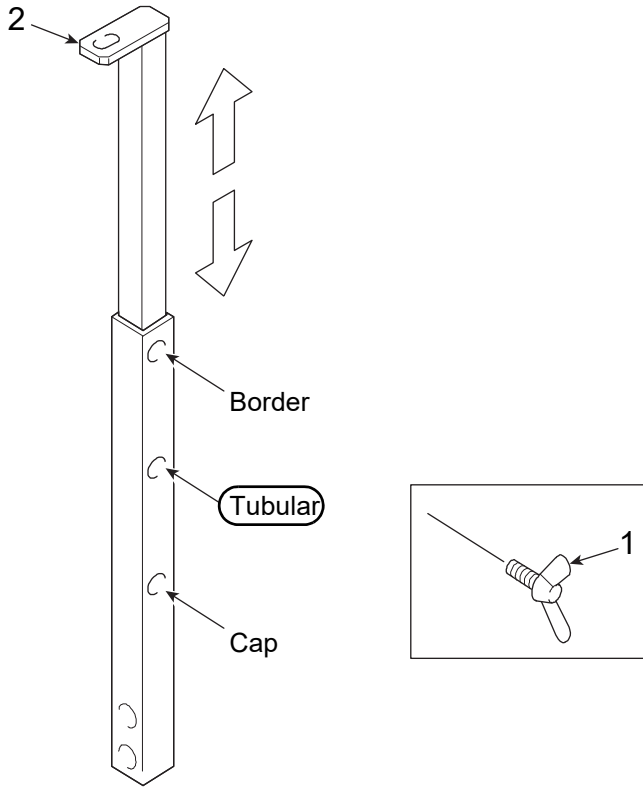

(5) Place the table 2 on the table holder 1 corresponding to the type of frame, and push it to the back firmly. Then tighten the screw 3.

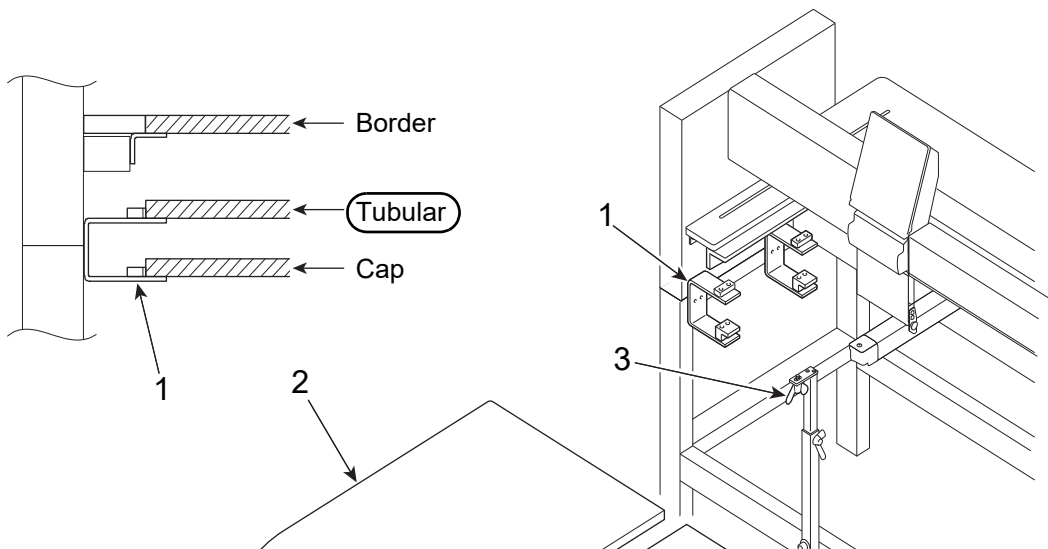

(6) Fix all toggle clamps 1.

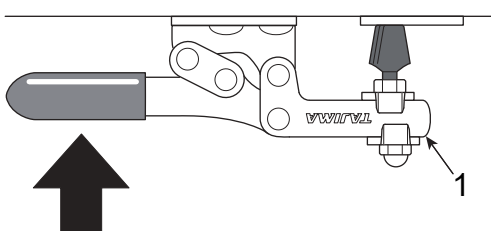

3. To attach tubular goods frame unit

(1) Attach the frame holder 1 by using the screw 2.

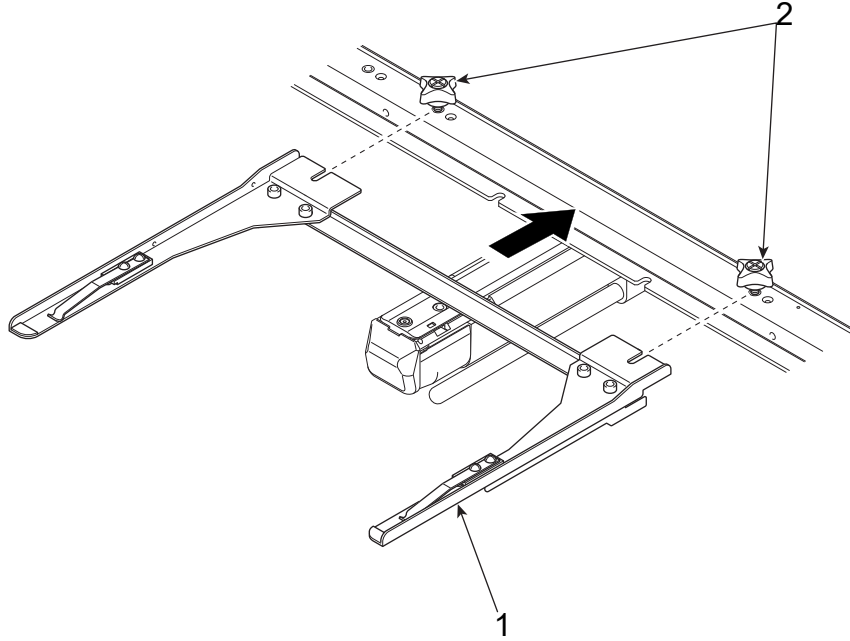

4. To change frame type

After replacing the frame, change the frame type according to the following procedure. It is not possible to change while embroidering.

(1) Screen

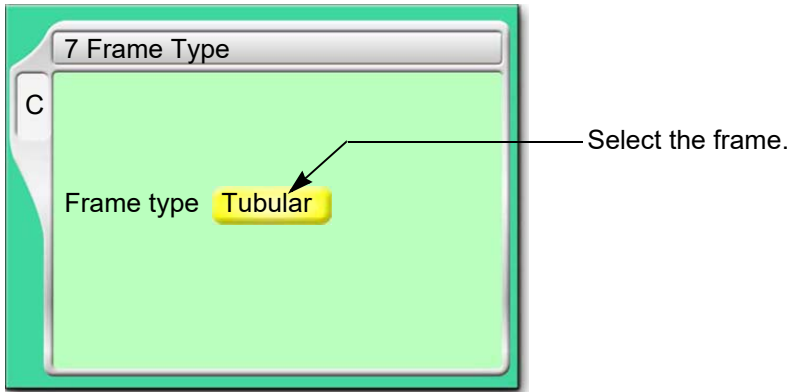

(2) How to operate

CAUTION

 When performing this operation, do not put your hands, etc. on the table. Moving the frame could injure you.

[a] To open screen

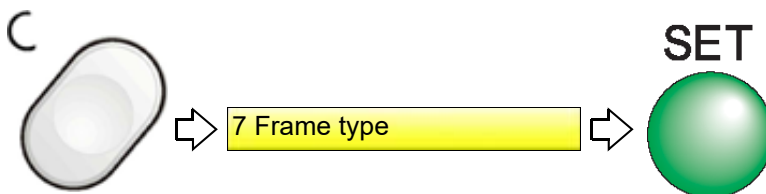

[b] To select the frame



[c] Execute Frame Origin Memory.

The message below is displayed only when "Frame origin memory with the Power-ON" ([SET]+F1-7) is set to YES.

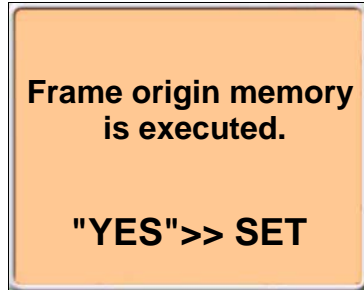

Pressing SET key will move the frame.

5. To set material

- (1) In order to fit the size of material, loosen the screw 1 to adjust the position of the arm 2.
- (2) Put the outer frame 4 on the gauge frame 3 and cover it with the material 5 (for example, sweat shirt).
- (3) Fit the inner frame 6 into the outer frame 4. At this time, check if the sweat shirt 5 has no shrinkage and evenly stretched.

 Depending on the material thickness, adjust the tightening degree of the outer frame 4 by using the screw 7.

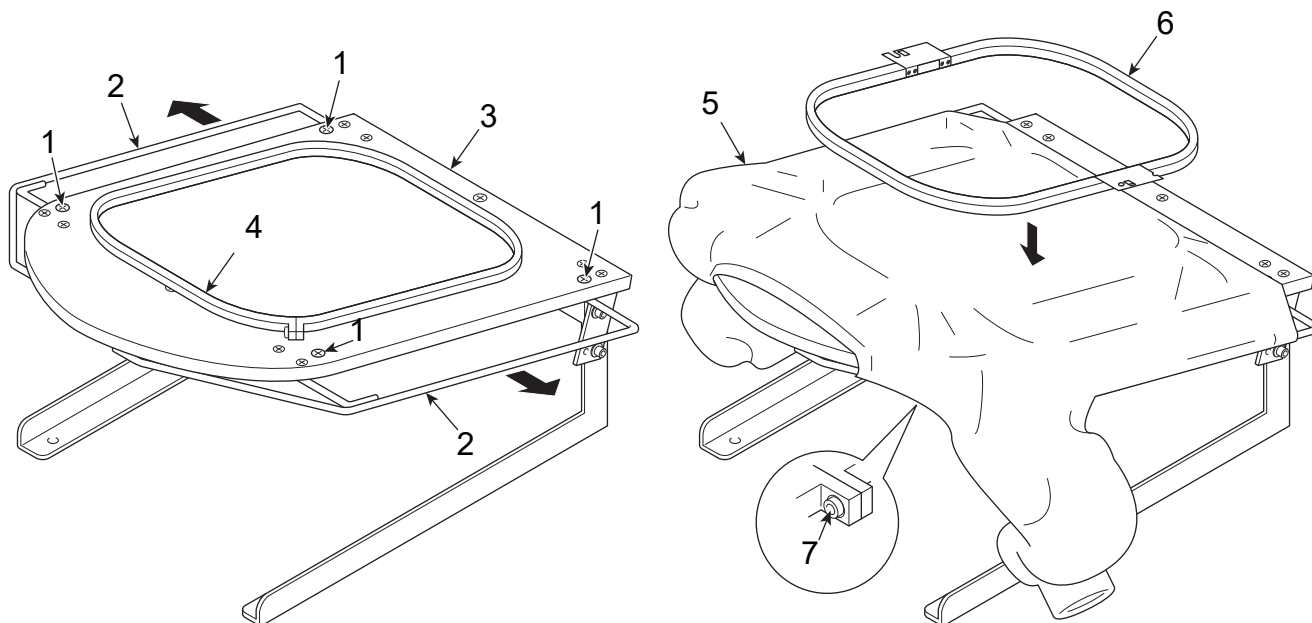

- (4) Set the tubular goods frame 1 to the frame holder 2, and push the 1 into the position (section A) where the arms 3 are locked.

 Check if there is no step or gap at section B.

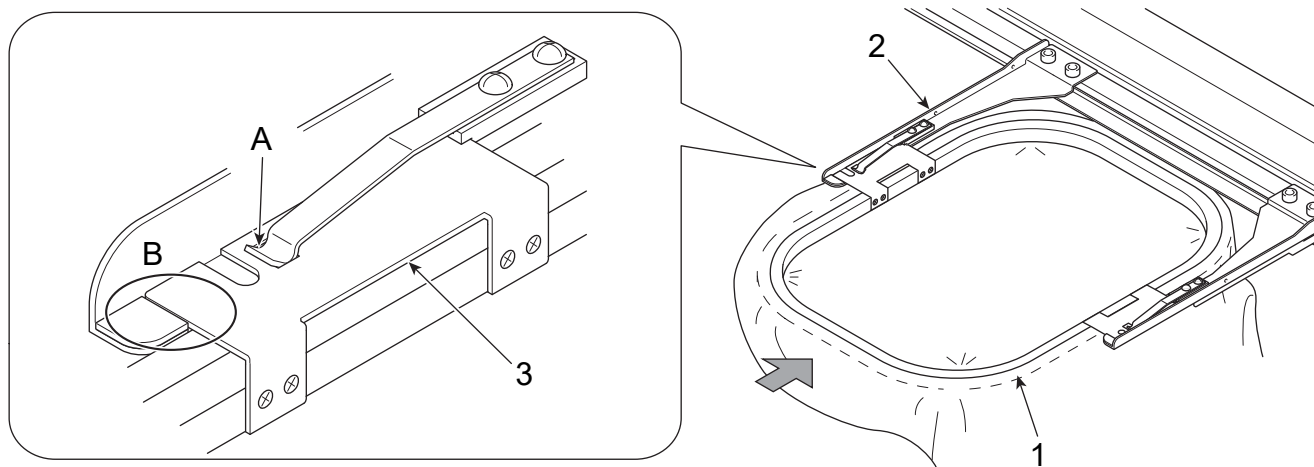

- (5)** Check if there is no play by moving the set tubular goods frame 1 back and forth.
When there is a play, loosen the screw 2, and clip the arm 3 between the pawl 4 and the positioning plate 5.
Then, tighten the screw 2 in the state that the frame presser spring 6 is fitted to the groove 7.

 Shape of the arm 3 differs depending on type of frame.

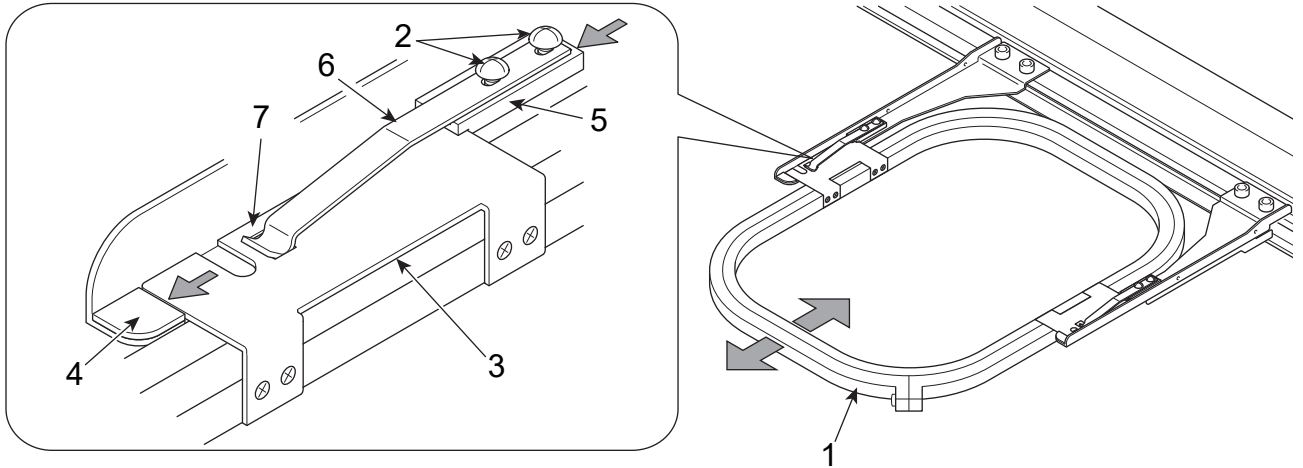

Replacement of the tubular goods frame, and the setting procedure of material are complete now.

Chapter 3 Border frame

CAUTION

 Perform the contents described in this chapter with the power switch OFF except for some of the work. Otherwise, you could be injured by unexpected malfunctioning of the machine.

1. To detach frame unit

1-1. Tubular goods frame

(1) Loosen screws 1 to detach the frame holder 2.

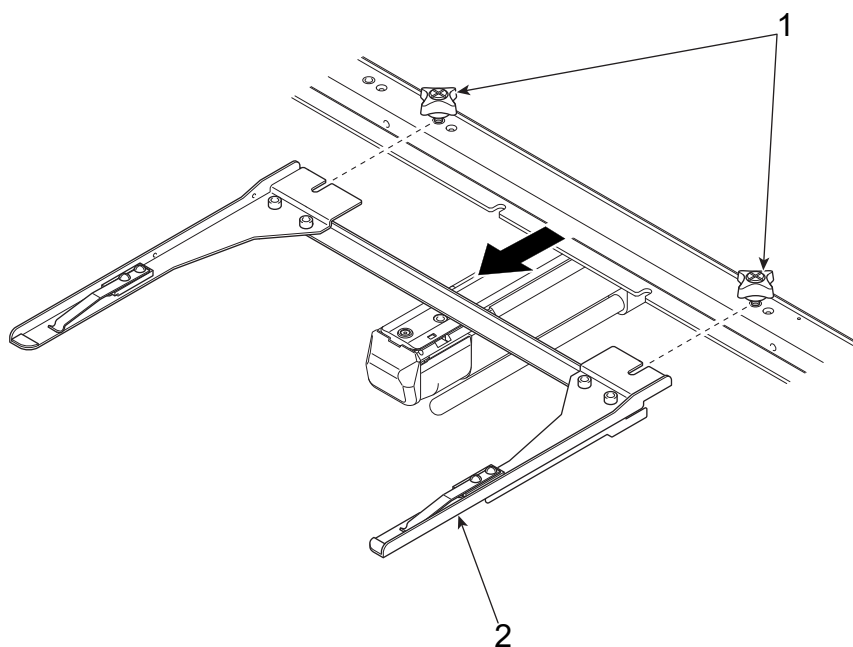

(2) After that, perform the following work.

"2.To change the height of table" (→P.26)

1-2. Cap frame

(1) Loosen screws 1 and 2 to detach the cap frame unit 3.

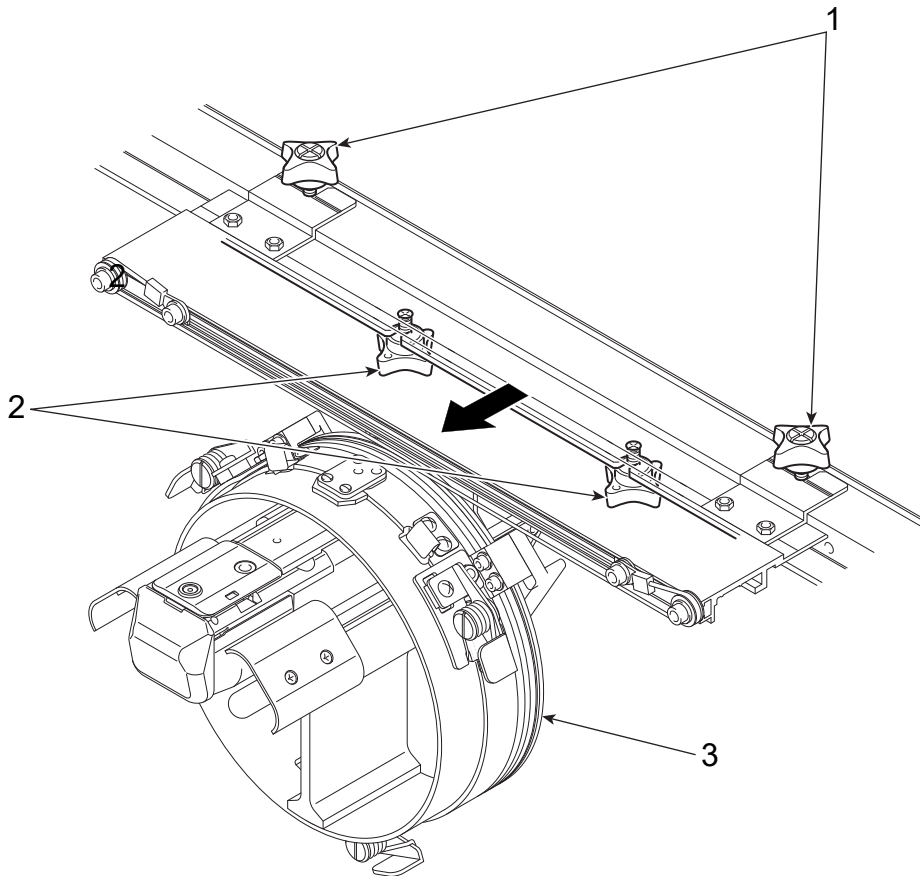

(2) After that, perform the following work.

"2.To change the height of table" (→P.26)

2. To change the height of table

(1) Release all toggle clamps 1 positioned at the bottom of the table.

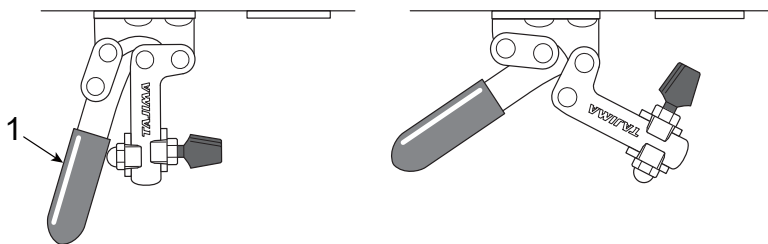

(2) Remove the screw 2 of the stay 1 under the table.

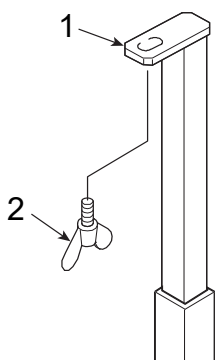

(3) Detach the table 1.

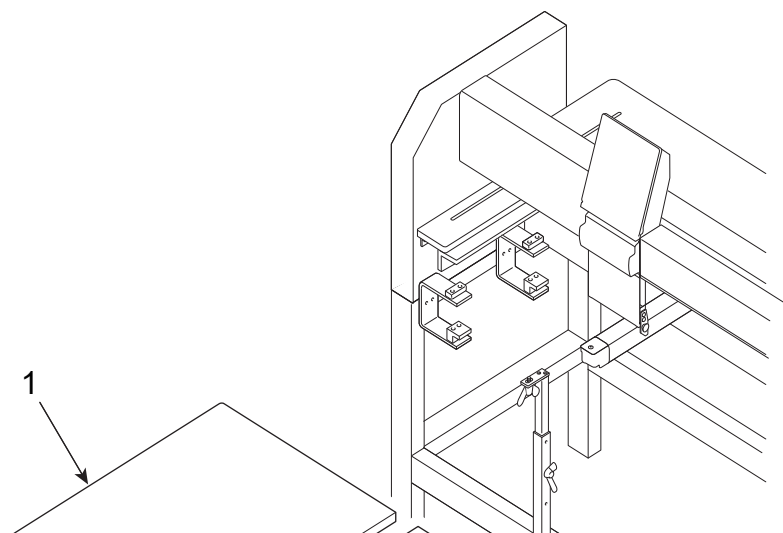

(4) Detach the screw 1, and tighten the screw 1 after adjusting the height of the stay 2 to the frame type.

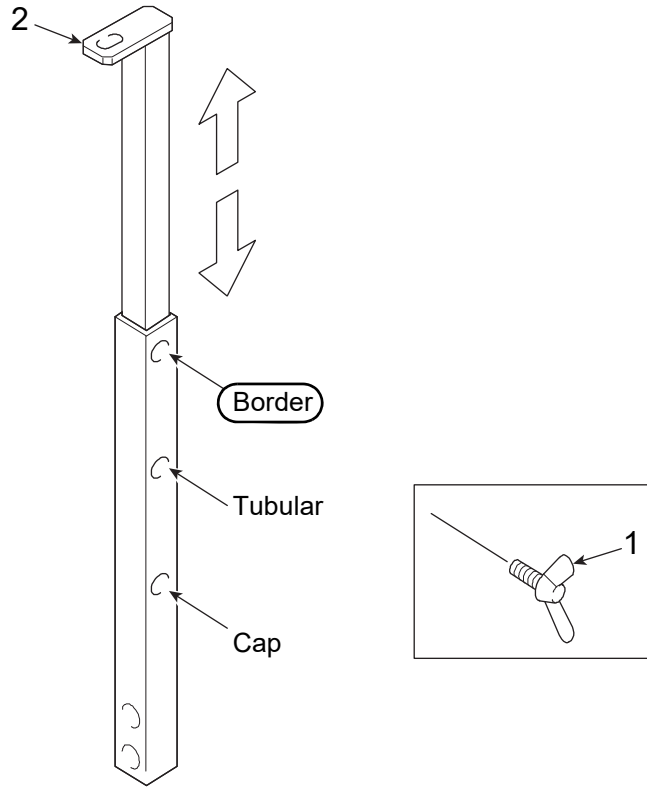

(5) Place the table 2 on the table holder 1 corresponding to the type of frame, and push it to the back firmly. Then tighten the screw 3.

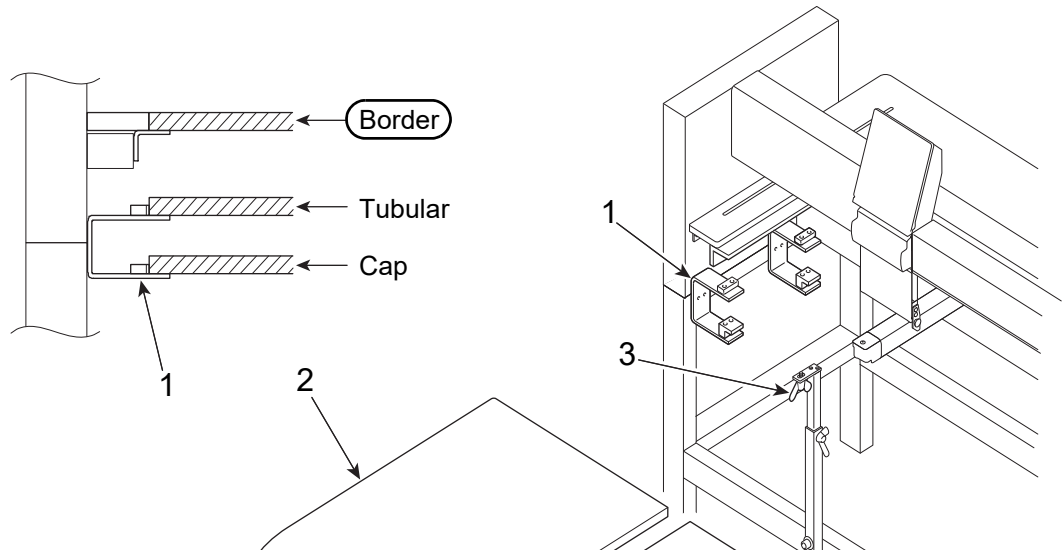

(6) Fix all toggle clamps 1.

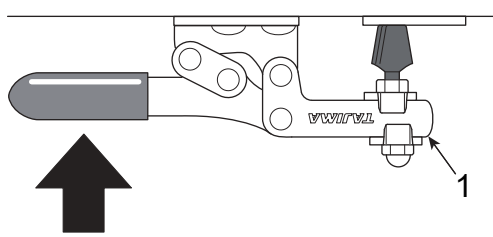

3. Attaching the border frame unit

(1) Check if the top 1 of the table almost accords with the top 2 of the needle plate.

When there is difference of 0.5 mm or more, loosen the screw 3 to adjust the attaching position of the stay holder 4.

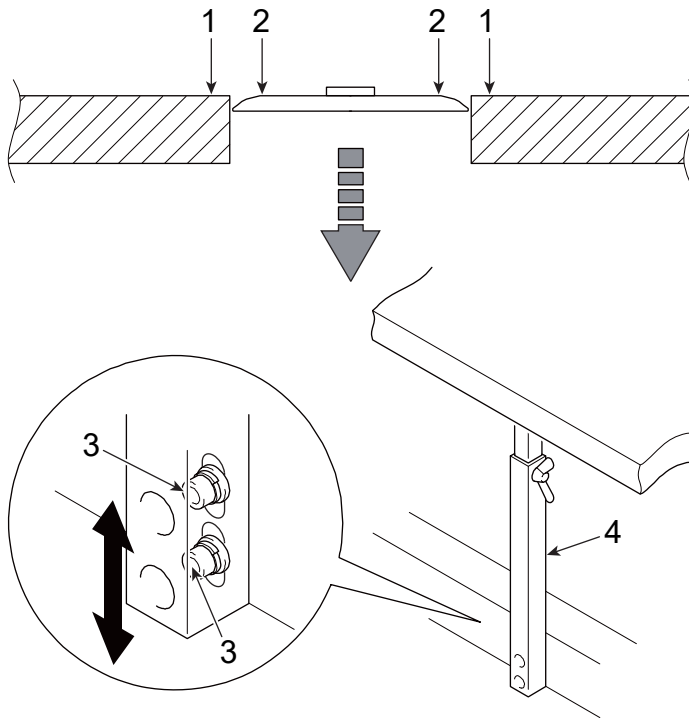

(2) Attach the border frame 1 by using screws 2.

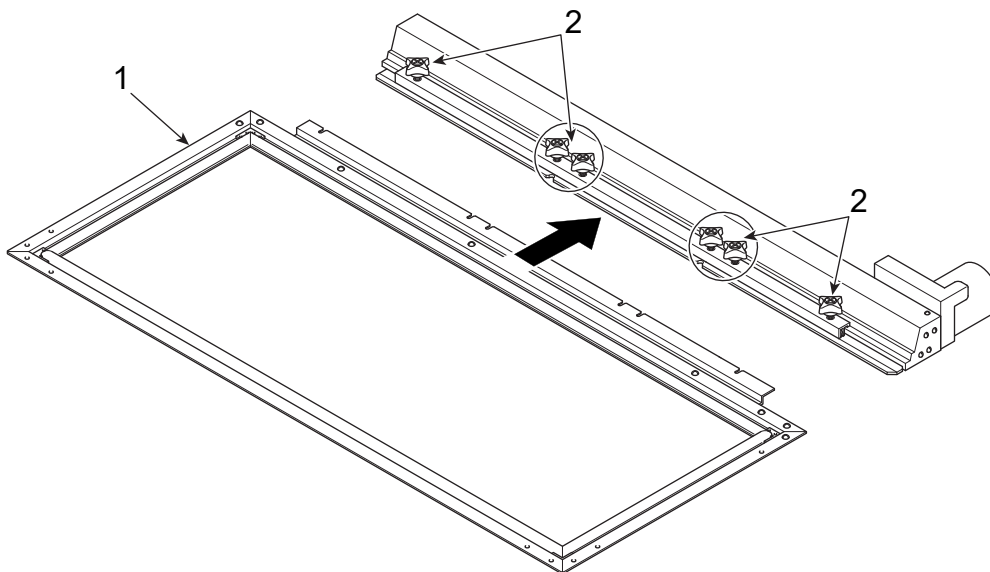

The exchange to border frame, and the setting procedure of the material are complete now.

4. To change frame type

After replacing the frame, change the frame type according to the following procedure. It is not possible to change while embroidering.

(1) Screen

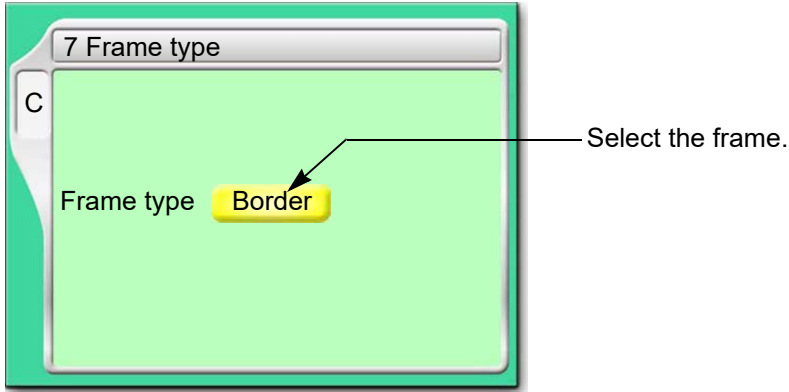

(2) How to operate

! CAUTION

⊘ When performing this operation, do not put your hands, etc. on the table. Moving the frame could injure you.

[a] To open screen

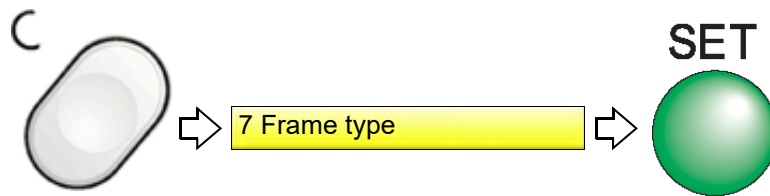

[b] To select the frame



[c] Execute Frame Origin Memory.

The message below is displayed only when "Frame origin memory with the Power-ON" ([SET]+F1-7) is set to YES.

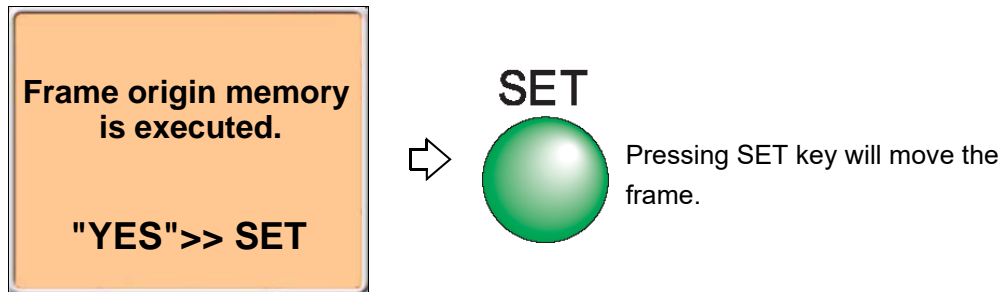

5. To set material

The type of clip 2 and its clipping method differ depending on the shape of the border frame sash 1. (Figure A, B)

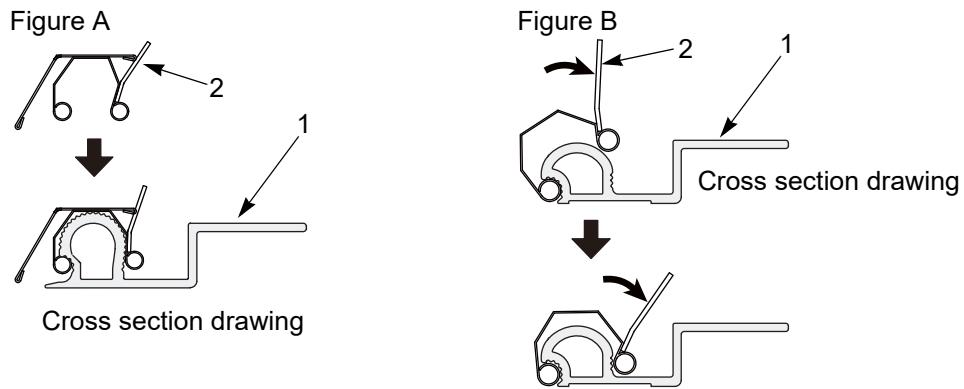

5-1. 2-head machine, 360P or less of 4-head machine

Fit the clip 1 and fix the material 2 to the border frame 3. There are various sizes of clip 1 in length. Arrange clips so that the fabric is fixed equally.

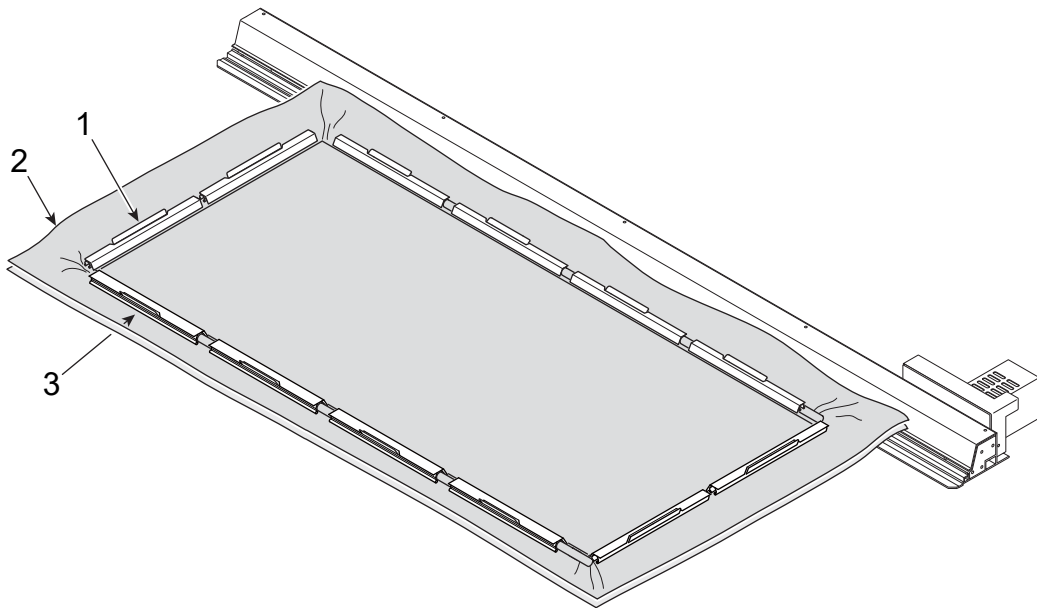

5-2. 500P or more of 4-head machine, 6-head machine, 8-head machine**CAUTION**

! Attach the middle supporter 4 when embroidering. When the middle supporter is detached, trouble such as displacement of design will occur.

Fit the clip 1 and fix the material 2 to the border frame 3. There are various sizes of clip 1 in length. Fix the middle supporter 4 to the border frame 3 securely.

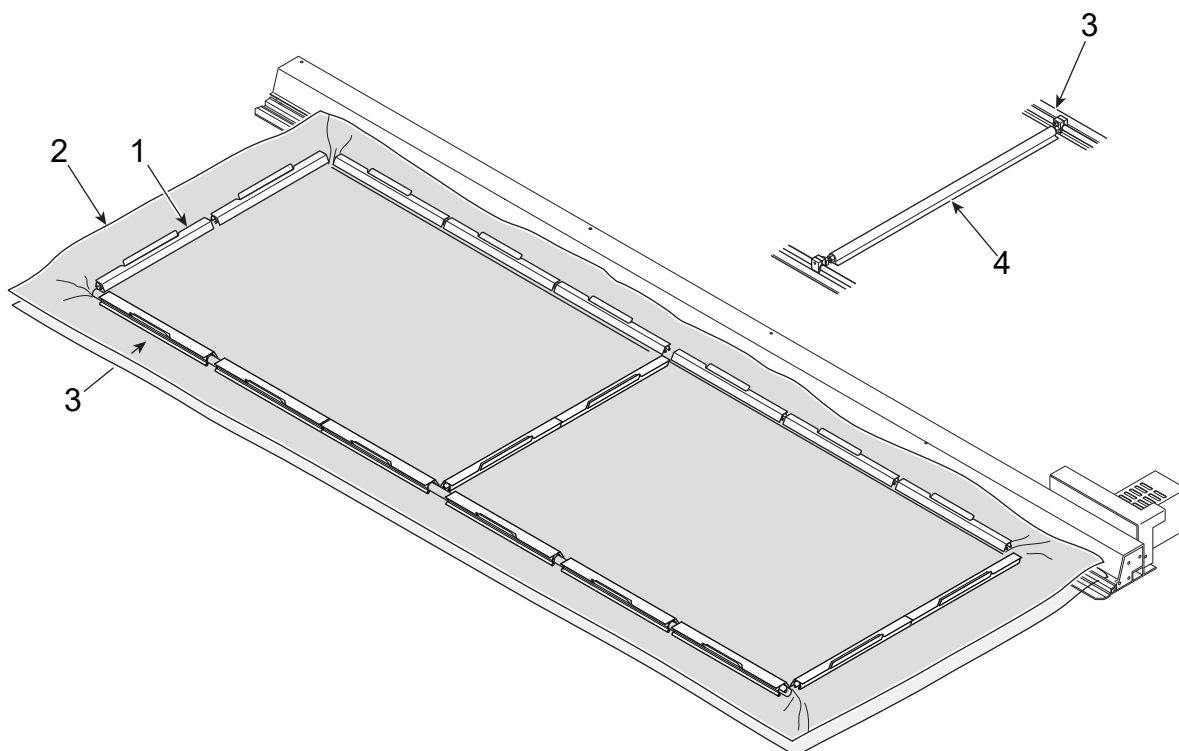

The exchange to border frame, and the setting procedure of the material are complete now.

Chapter 4 Adjustment and maintenance

1. To attach the drive ring shaft

If the drive ring shaft 2 is not attached under the cylinder bed 1, attach in the following procedure.

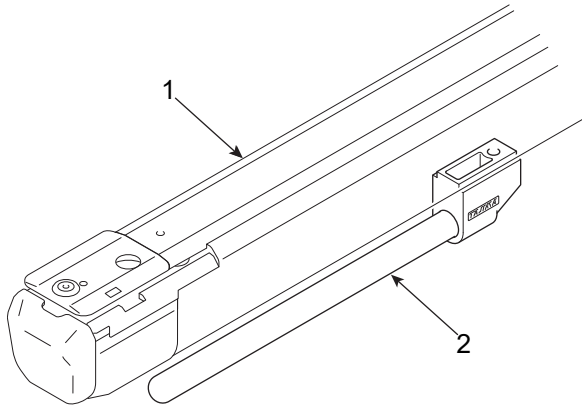

(1) Attach the drive ring shaft 2 to the shaft base 1 by fixing with the screw 3 (hexagon socket head set screw).

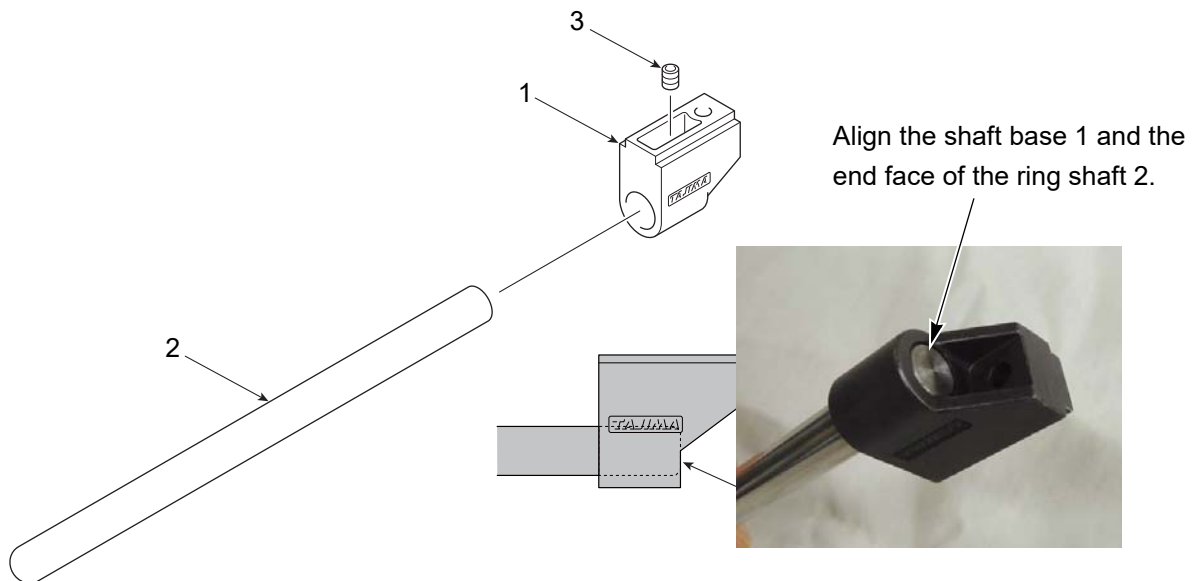

(2) Attach the shaft base 2 to the bottom face of the cylinder bed 1 with the screw 3 (hexagon socket head cap screw M5*25).

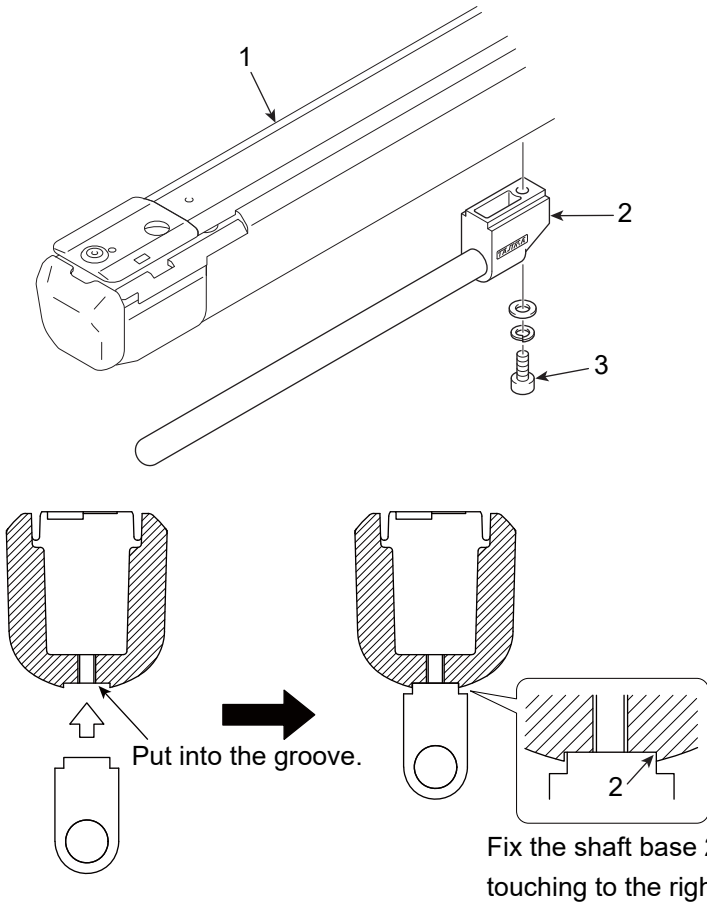

2. To adjust the position of cap frame unit

If the cap frame unit does not move smoothly even if you try to move back and forth, loosen the screw 2, and tighten the screw 2 at the position where the drive ring base becomes level and the cap frame unit moves smoothly.

At this time, the gap between Drive ring 3 and Cylinder cover 4 is 1.5mm.

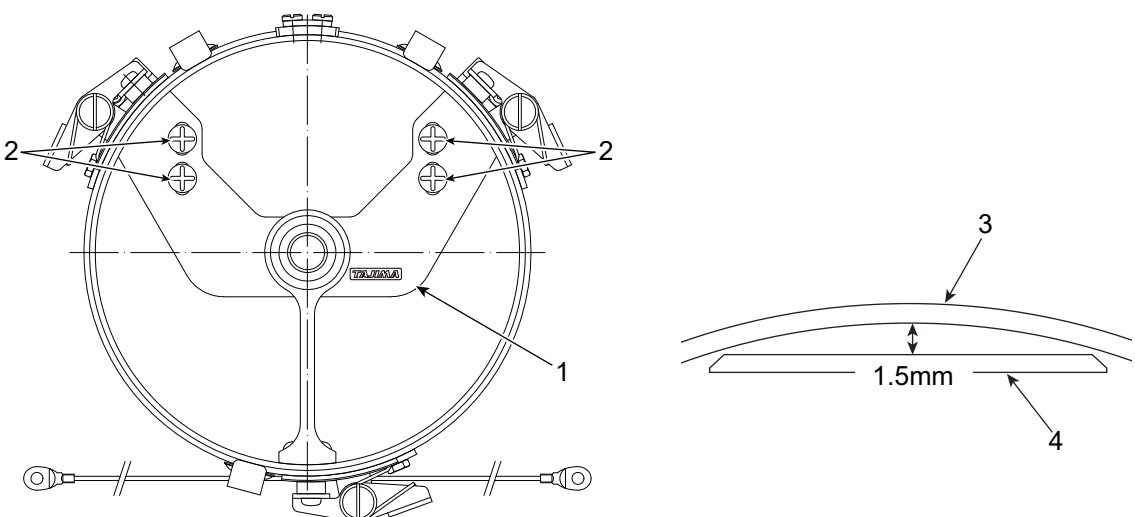

3. To adjust the tension of drive wire

Perform this work when tension of the drive wire becomes loose and/or the center of cap frame unit is misaligned during storage of the cap frame unit.

⚠ CAUTION

⚠ Perform the contents described in this chapter with power OFF or sleep mode. Otherwise, you could be injured by unexpected malfunctioning of the machine.

- (1) Turn OFF the power.
- (2) Move the frame in right/left direction to align the right end 1 of the slide base with the scale (chart below) of the scale sheet 2.

Frame Spec.	Scale
360P	0
500P	7

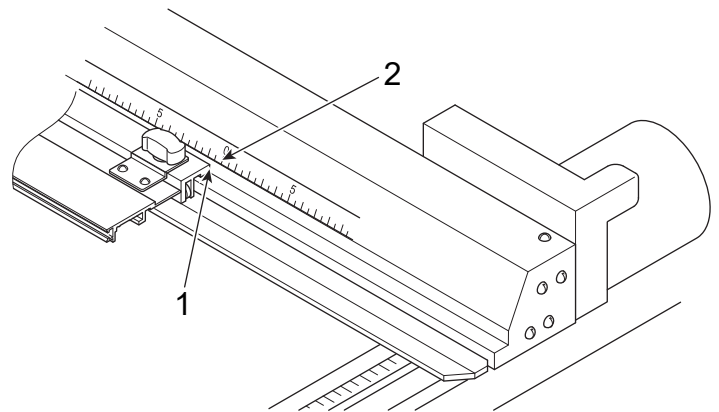

- (3) Turn the nut 2 of the tension gauge 1, and move the block 3 to the innermost.

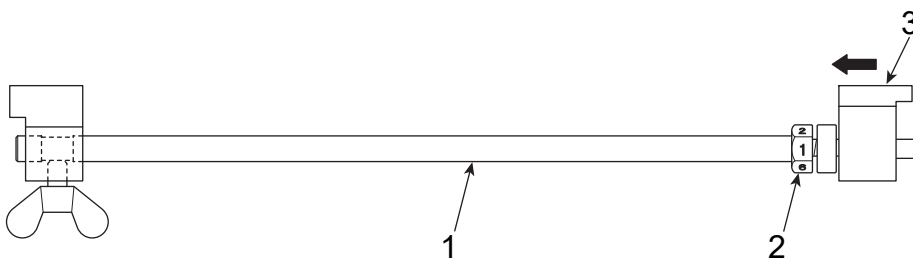

(4) After setting the tension gauge 1 between the plate nut 2 and 3, loosen the screw 4.

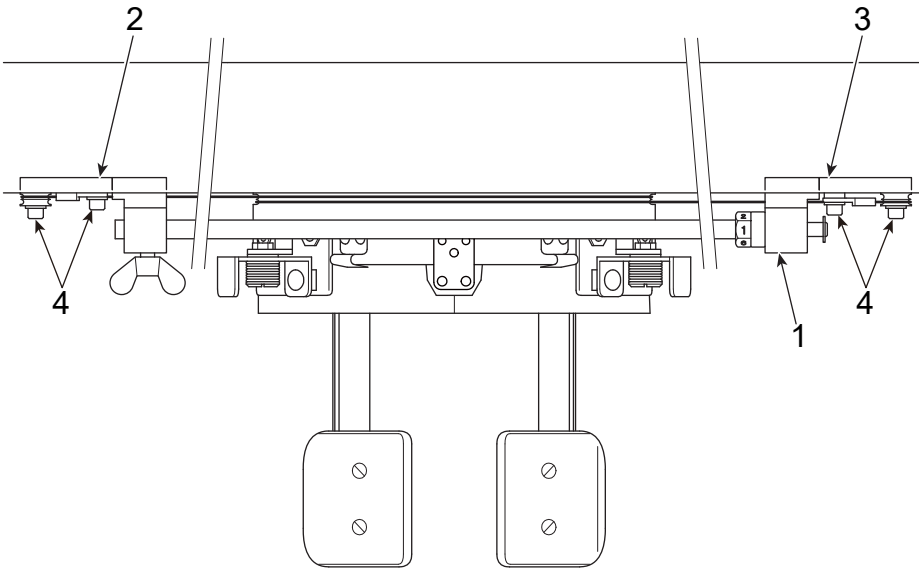

An example of attaching the tension gauge 1



(5) Rotate the nut 2 by hand to the direction where the block 1 moves to the right. Rotate the 2 further by 4/6 turns using a wrench from the position when it stops.

 To rotate the nut 2, take the engraved numbers as rough standard.

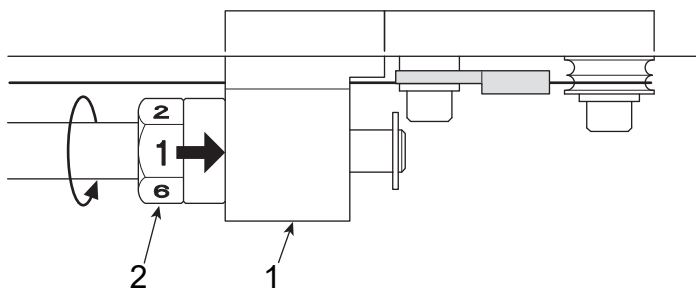

(6) Being careful not to move the drive system in right and left, turn the drive ring 1 by hand to align the center mark 2 with the center 3 of the needle hole.

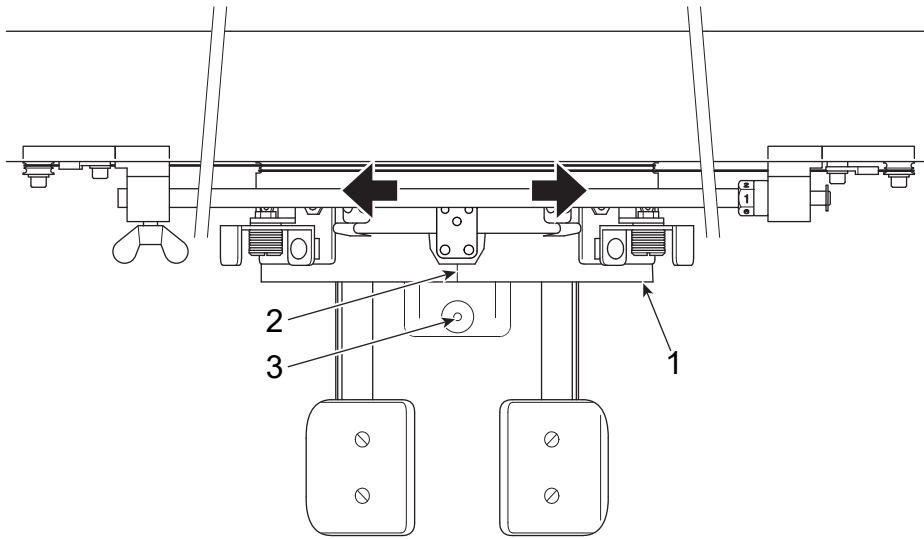
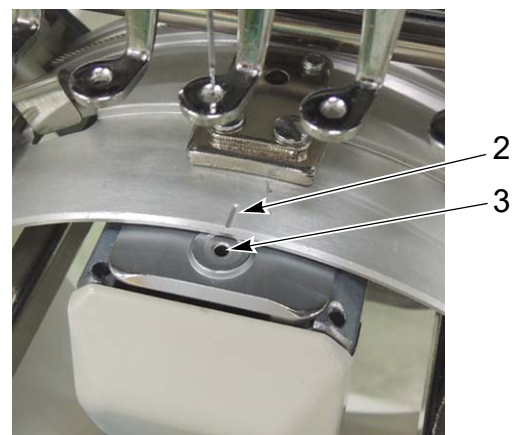

Photo 1



Photo 2



- (7) Check if the wire 1 does not come off from the groove, and then tighten the screw 2.
- (8) Remove the tension gauge 3.

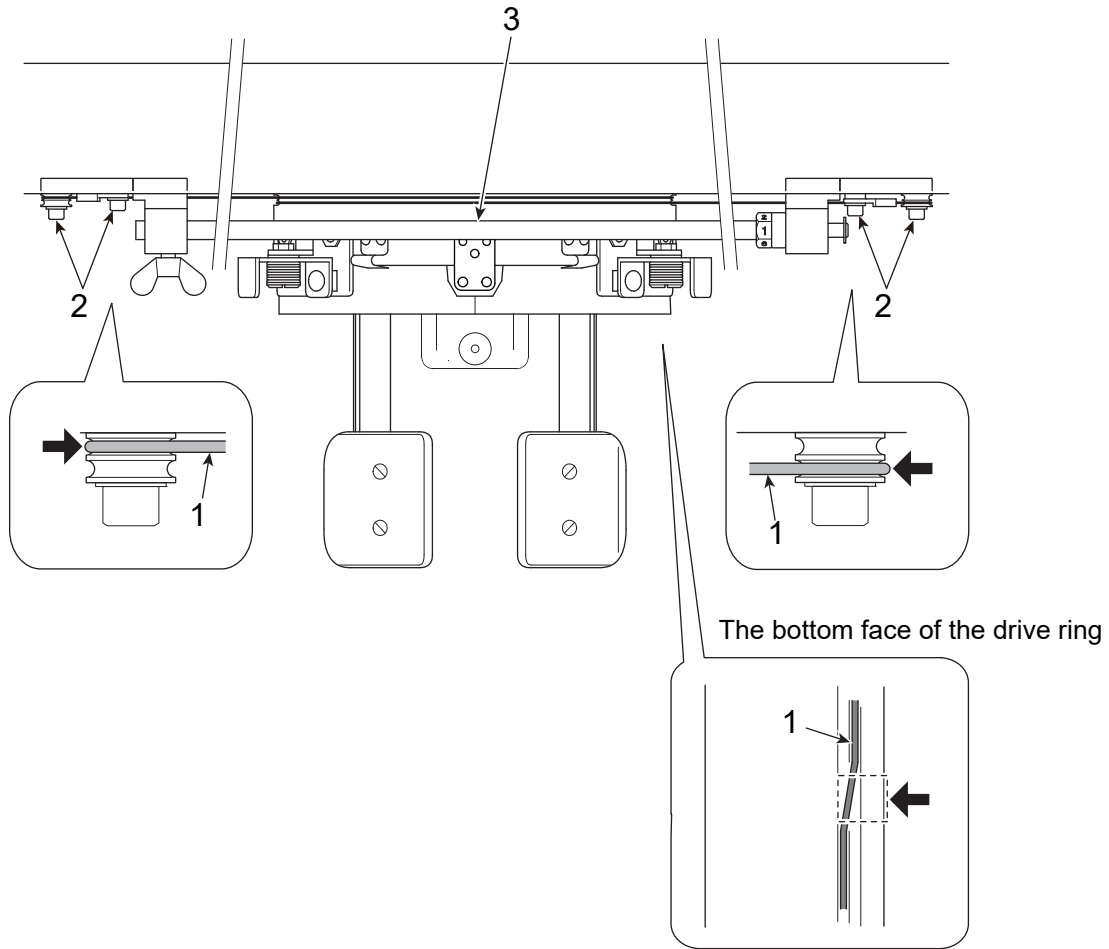

Hang the wire 1 correctly in the groove.

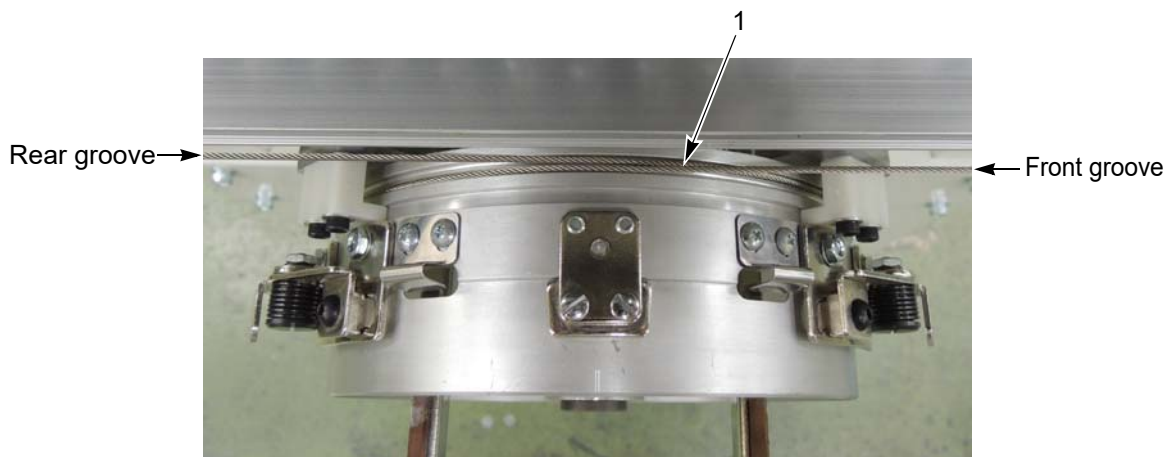

4. Periodic inspection

Perform periodic inspection of the cap frame unit once for three months, and replace if there are worn parts. We recommend early replacement of the parts in red circle because the finishing is affected. For the parts name and parts number, refer to the separate parts list.

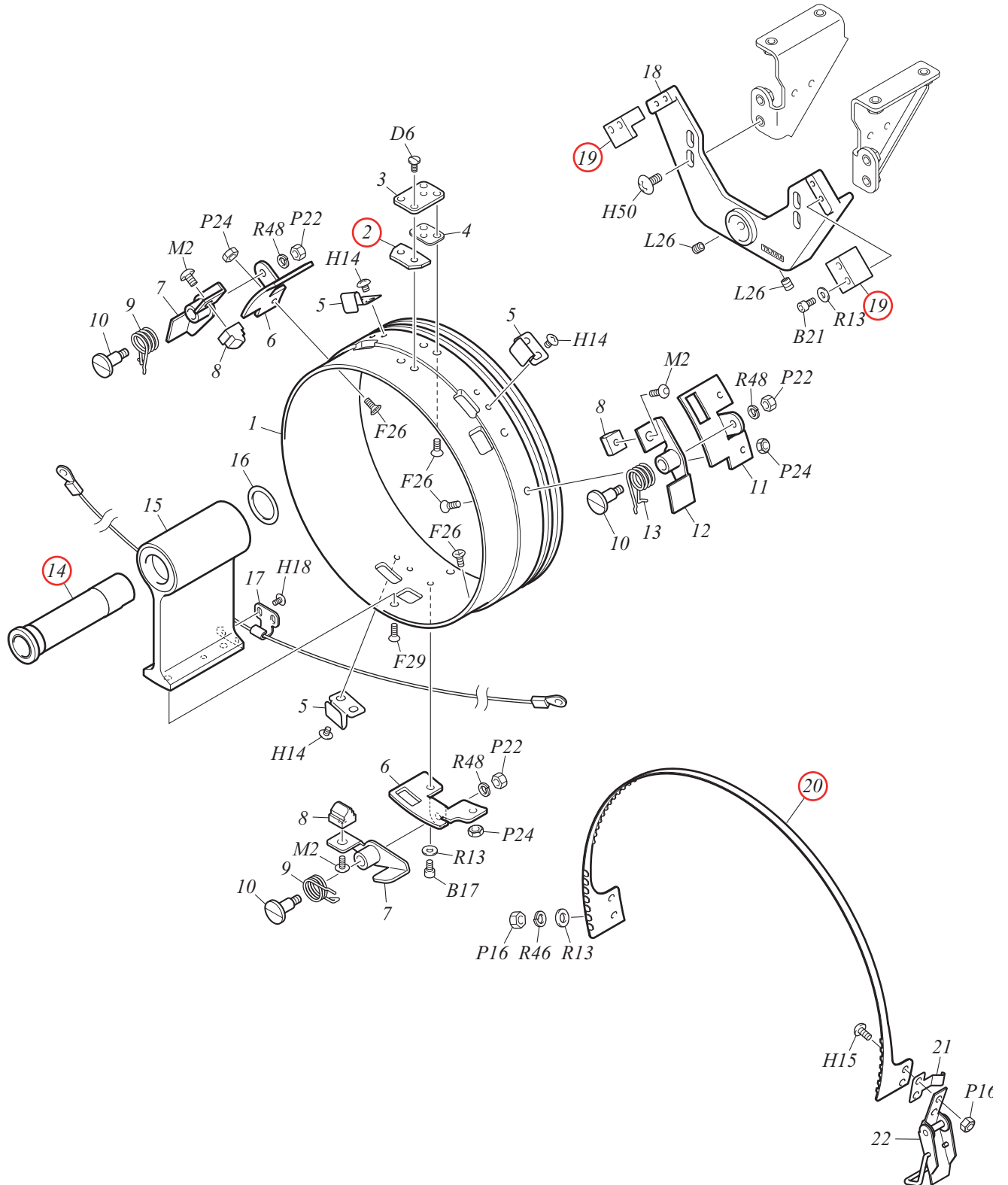

1st Edition July, 2010
9th Edition May, 2019

■ **Manufactured by : TISM Co.,Ltd.**

Address : NO.1800, Ushiyama-cho, Kasugai, Aichi-pref., 486-0901, Japan
TEL : 81-568-33-1161 FAX : 81-568-33-1191

■ **Distributed by : Tajima Industries Ltd.**

Address : NO.1800, Ushiyama-cho, Kasugai, Aichi-pref., 486-0901, Japan
TEL : 81-568-37-1130 FAX : 81-568-37-1230

●**Copy, reprint, or reform of a part or whole of this manual without permission is prohibited.**