



USER'S MANUAL

# Basics

This manual describes the basic knowledge and procedures that are common to all the models and required to use the machine.

If you are a novice to or unfamiliar with the machine, be sure to read this manual first.

# For embroidery machines



# Foreword

Thank you for purchasing the TAJIMA embroidery machine.

Please read this manual thoroughly, understand the contents, and then use the machine.

This manual may contain discrepancies in detailed specifications when compared with the actual product. If you have any question, please ask the distributor for information.

## Purpose of This Document

This manual and other documents contain the following information. Refer to the necessary documents depending on the application and purpose. The user's manual and other documents are stored as PDF files on the supplied DVD.

### ■ USER'S MANUAL

#### For Safe Use

This manual contains instructions on using the machine safely. Make sure to read the manual before use.

#### Basics (this document)

This manual describes the basic knowledge and procedures that are common to all the models and required to use the machine.

If you are a novice to or unfamiliar with the machine, be sure to read this manual first.

#### Operation

This manual describes the basic procedures for operating the machine, performing embroidery, and performing maintenance.

#### Parameter Setting

This manual describes various parameters.

#### Frame Change

This manual describes how to change the frames.  
This does not come with some models.

#### Various Documents

Electrical system diagrams and other technical documents.

### ■ Other manuals

#### Quick Guide

This sheet is the Quick reference regarding embroidery methods as well as frequently used functions and their operation procedures.



Keep the Quick Guide handy so that you can reference it quickly.

#### Optional Device

This manual describes how to set up, operate, and maintain various optional devices.

# Safety Precautions and Symbols



Items that require your special attention on handling the machine are specified below.

Description	Meaning
 <b>DANGER</b>	Indicates that there is a lot of danger of death or serious injuries* <sup>1</sup> .
 <b>WARNING</b>	Indicates that there is a likelihood of death or serious injuries* <sup>1</sup> .
 <b>CAUTION</b>	Indicates a potentially hazardous situation which may result in minor or moderate injury* <sup>2</sup> or physical damage.



\*1: A condition caused by electric shock, injury, fracture of a bone etc. that leads to aftereffects, or an injury that necessitates hospitalization or visits to a hospital over a long period.

\*2: An injury that does not necessitate hospitalization or visit to a hospital over a long period.

The symbols used throughout this document have the following meanings.

Symbol	Meaning
	Item to be prohibited
	Items that may cause electric shock if not observed
	Items to keep safety

## Other Precautions

Description	Meaning
	Items that may affect sewing if not observed.
	Recommended and useful tips.

## Disclaimer, etc.

- The external views and specifications of the machine and the contents of this manual are subject to change without notice due to improvement.
- The screen captures and figures contained in this manual may differ depending on the machine specifications, the number of heads or needles, and the presence of optional device.
- TAJIMA bears no responsibility regarding any damage arising from not observing the instructions in the manual or any fault or damage resulting from repair, disassembly, or modification not indicated in the manual.
- You may not copy, reproduce, or transcribe a part or whole of this manual without consent of TAJIMA.

## Chapter 1

**Parts and Their Functions**

1. Embroidery Machine Configuration .....	5
1-1. Multi head machine (flat type) .....	5
1-2. Multi head machine (cylinder type) .....	6
1-3. Machine with smaller number of heads (cylinder type) .....	7
1-4. Single head machine (cylinder type) .....	7
2. Main Parts and Their Functions .....	8
2-1. Embroidery head .....	8
2-2. Rotary hook base, cylinder bed .....	10
2-3. Operation panel .....	11

## Chapter 2

**Needles**

1. Usable Needles .....	12
1-1. Standard needles .....	12
1-2. Benefits of using standard needles .....	12
2. Guidelines on Needle Selection .....	13
2-1. Upper thread and needle compatibility list .....	13
2-2. Variation of needle tip styles .....	14
3. Replacement of needle .....	15
3-1. Needle replacement criteria .....	15
3-2. Checking if the needle is bent .....	15
3-3. Needle Replacement .....	16

## Chapter 3

**Preparation of Threads**

1. What Threads to Use .....	17
1-1. Upper threads .....	17
1-2. Under threads .....	18
2. Setting the Upper Threads .....	19
2-1. Thread spool layout and threading positions .....	19
2-2. Setting the thread spools .....	20
2-3. How to pass the upper threads .....	21

## Table of contents >>

3. Setting the Under Threads .....	27
3-1. How to set the bobbin to the bobbin case .....	27
3-2. How to set the bobbin case to the rotary hook .....	28
4. Adjustment of thread tension .....	29
4-1. Adjusting the upper thread tension (Standard head, DCP head) .....	29
4-2. Adjusting the under thread tension .....	31

### Chapter 4

## Fabric Stretching

---

1. How to Stretch the Fabric on the Border Frame .....	32
1-1. How to use the clips .....	32
1-2. How to stretch the fabric .....	33
2. How to Stretch the Fabric on the Tubular Goods Frame .....	34
2-1. What frame to use .....	34
2-2. How to stretch the fabric .....	35
2-3. Using tubular goods gauge frame sets .....	36
3. Preventing Fabric Puckering .....	38
3-1. Guidelines on sheet selection .....	38
3-2. How to use sheets .....	39
4. How to use the middle sash (accessory) .....	40
4-1. About stays .....	40
4-2. Installation method (when using the one-touch frame) .....	42
4-3. Installation method (when not using the one-touch frame) .....	44
4-4. Quantity of stays and breakdown of accessories .....	46

## Chapter 1

# Parts and Their Functions

## 1. Embroidery Machine Configuration

TAJIMA embroidery machines are classified into flat and cylinder types. The flat type machines are suitable for embroidery on cut or original fabric while the cylinder type machines are suitable for embroidery on cylindrical products such as completed clothes or hats/caps.

In addition, TAJIMA embroidery machines are available in different configurations including multi head machines, machines with smaller number of heads, and single head machines, which differ in the number of embroidery heads. Typical machine configurations are described below.



- Depending on the model, specifications, etc., TAJIMA embroidery machines are different in terms of the number of heads, the stand structure, and the layout of various components, and so on.

### 1-1. Multi head machine (flat type)

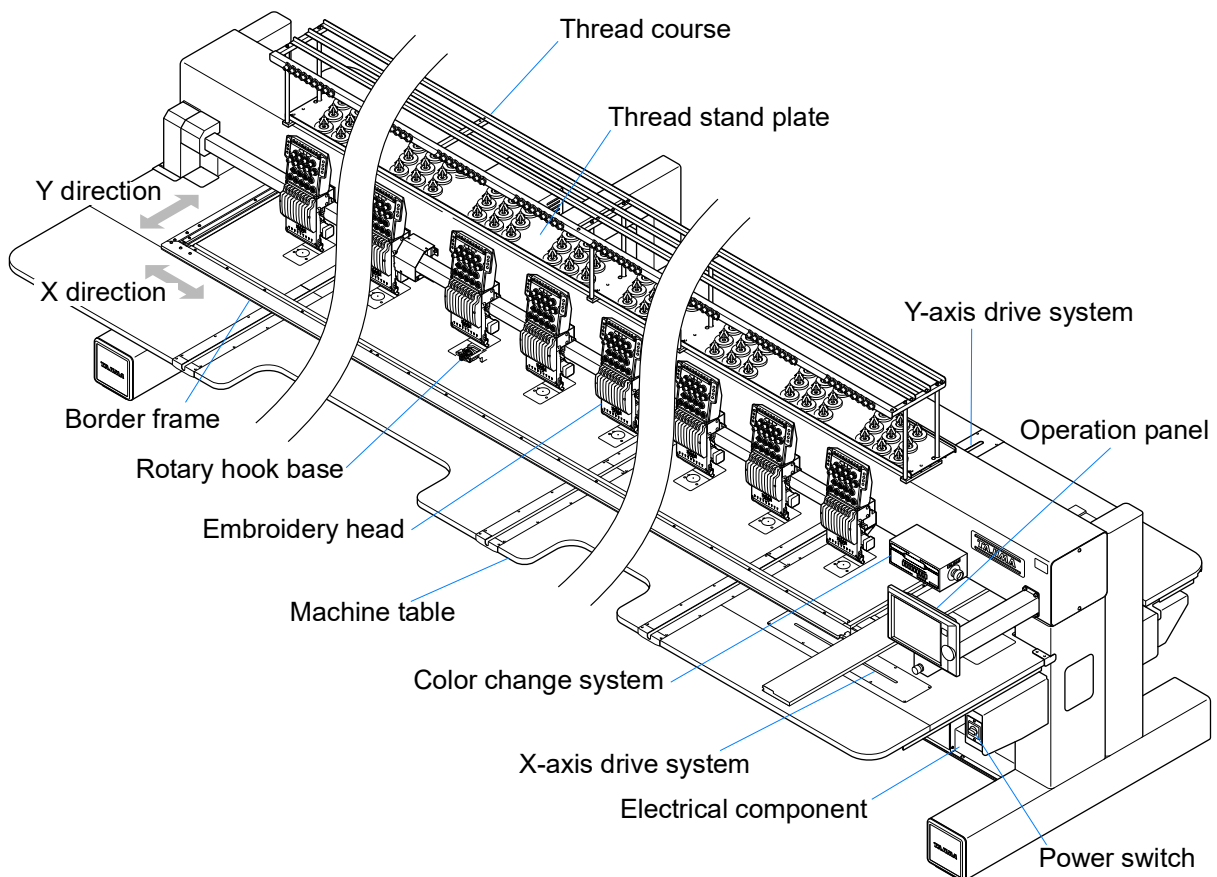

- The side on which the machine operation panel is installed is referred to as the “right side” and the opposite side as the “left side”.
- When the frame moves between the left and right, it moves in the “X direction”; when it moves between the front and back, it moves in the “Y direction”.

## 1-2. Multi head machine (cylinder type)

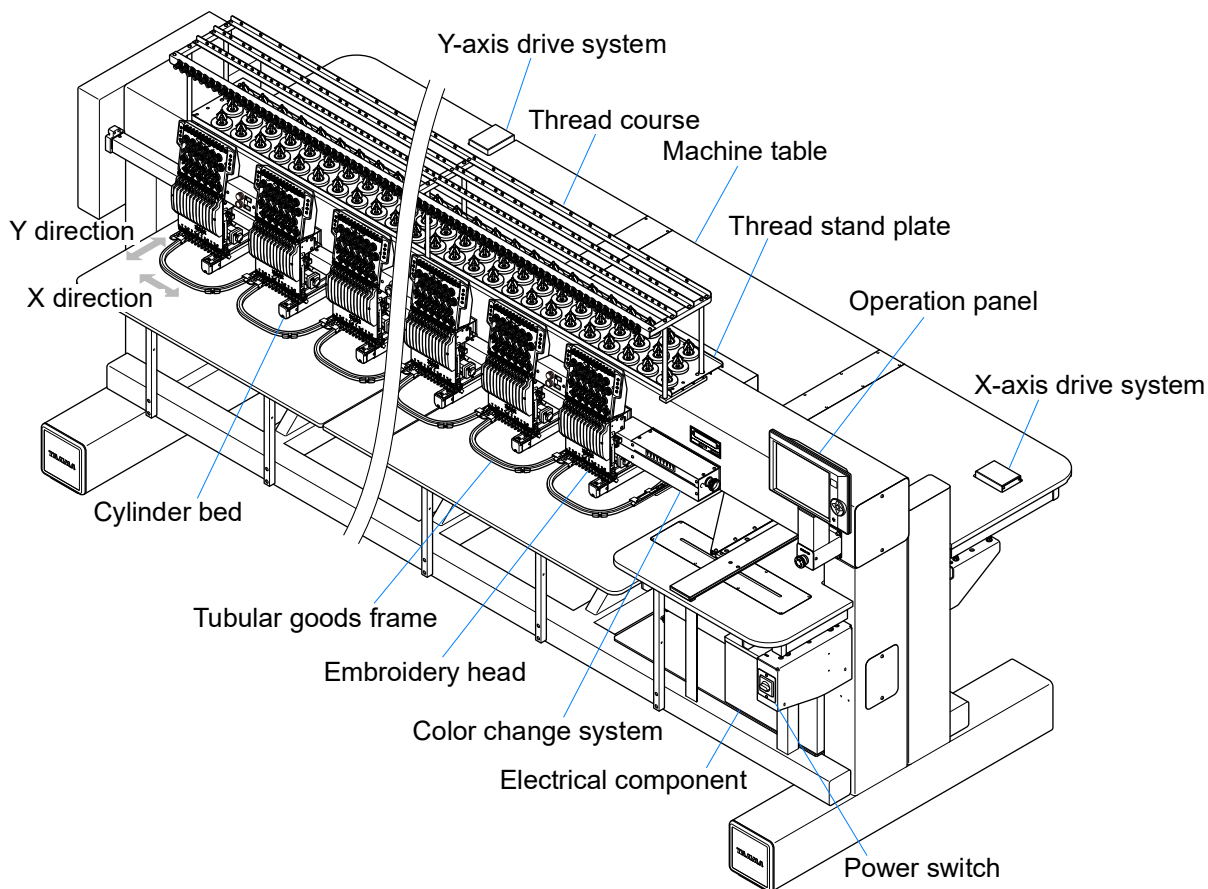

### 1-3. Machine with smaller number of heads (cylinder type)

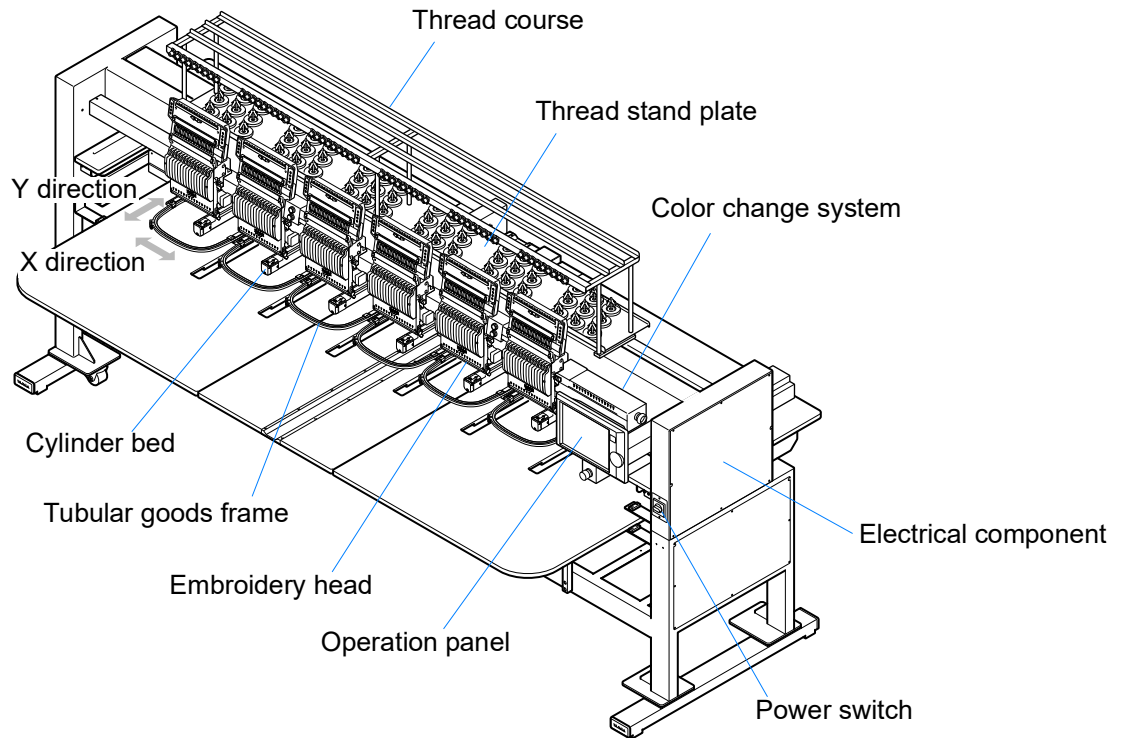

### 1-4. Single head machine (cylinder type)

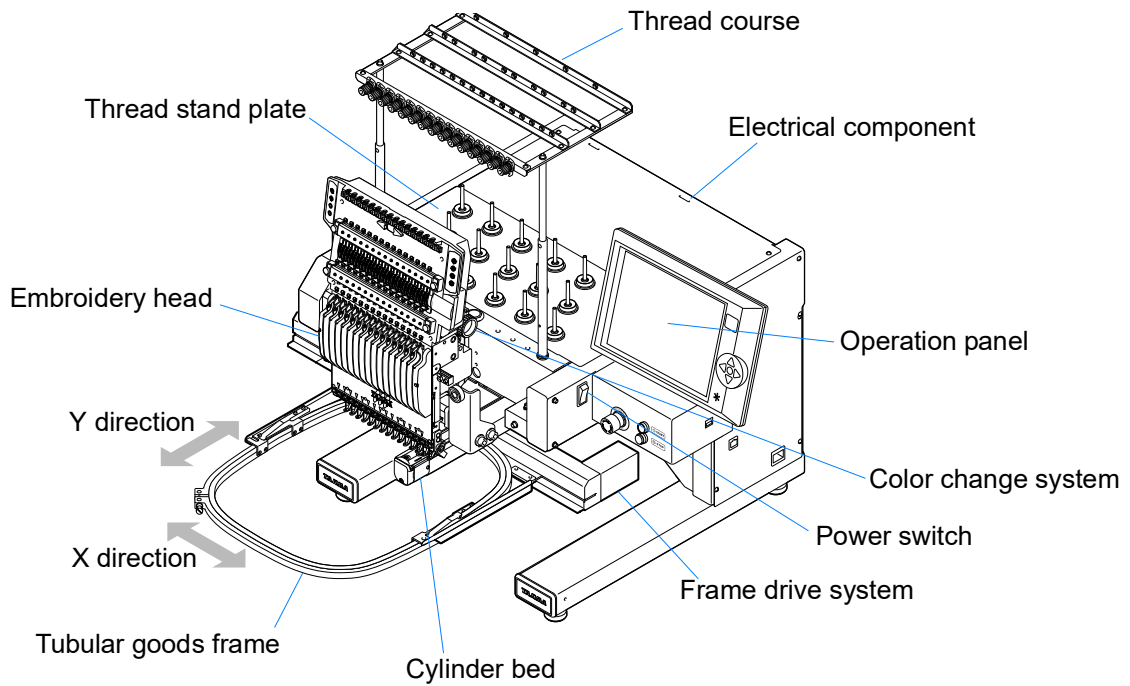

# 2. Main Parts and Their Functions

This section describes the names and functions of the main parts of the machine.

## 2-1. Embroidery head

Embroidery heads are available in three types: standard head (mechanically driven presser foot), DCP head (motor-driven presser foot), and i-TM head (equipped with i-TM).

The type of embroidery head varies depending on the model.

### Standard head, DCP head

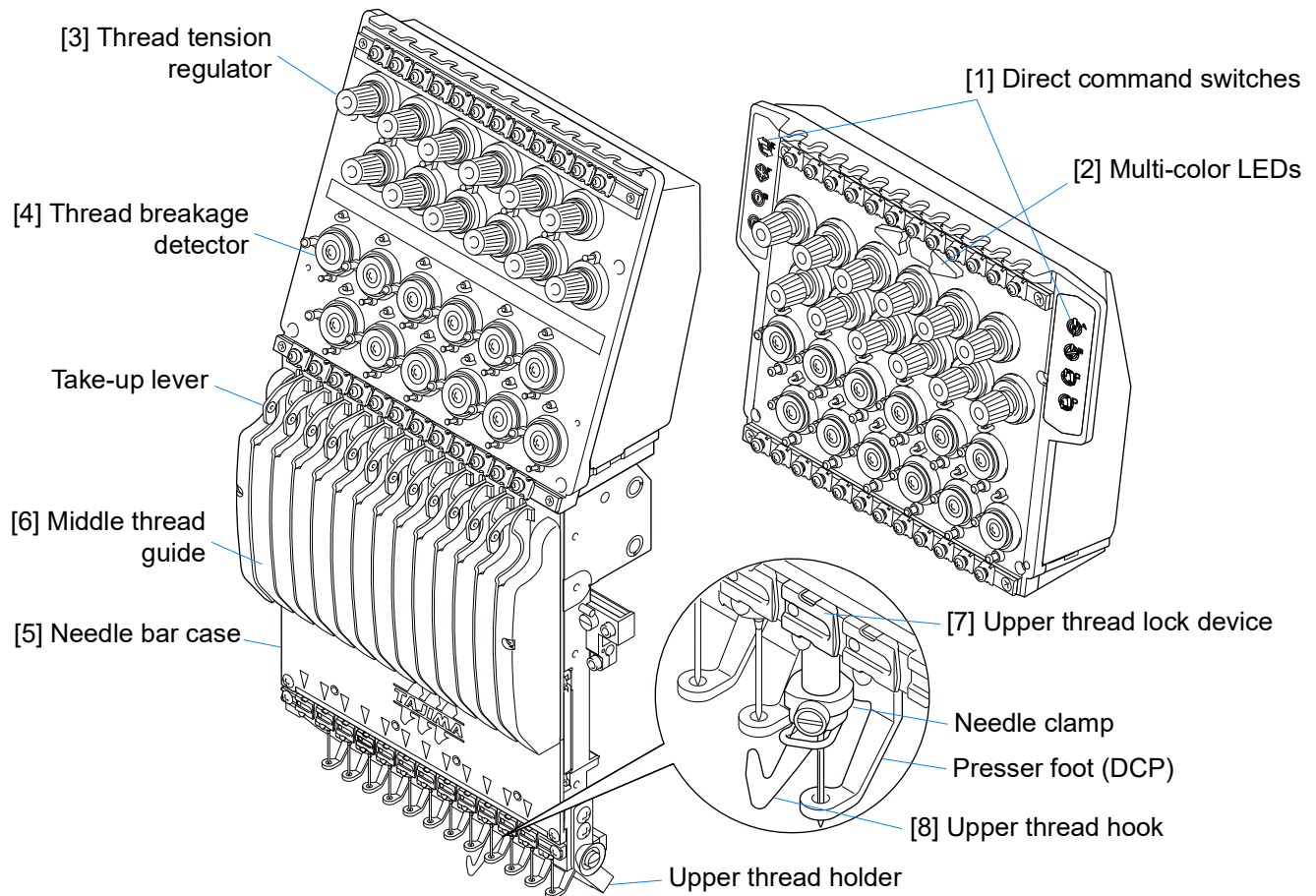

[1]	The switches for performing specific functions are provided. They allow you to perform specific functions without having to access the operation panel.	[5]	Slides laterally to align the selected needle to the sewing point.
[2]	These LEDs turn ON or flash in various colors to indicate changes in status or the occurrence of thread breakage, etc.	[6]	Absorbs the slack of the upper thread with the built-in thread take-up spring to stabilize the tension of the upper thread.
[3]	Adjusts the tension applied to the upper thread.	[7]	Fixes or releases the upper thread appropriately during sewing.
[4]	Stops the machine upon detecting a broken thread.	[8]	Hooks the upper thread after trimming so that the upper thread holder can retain it.



- Needles (needle bars) are numbered 1, 2, 3, and so on from the right to the left.

**i-TM head**

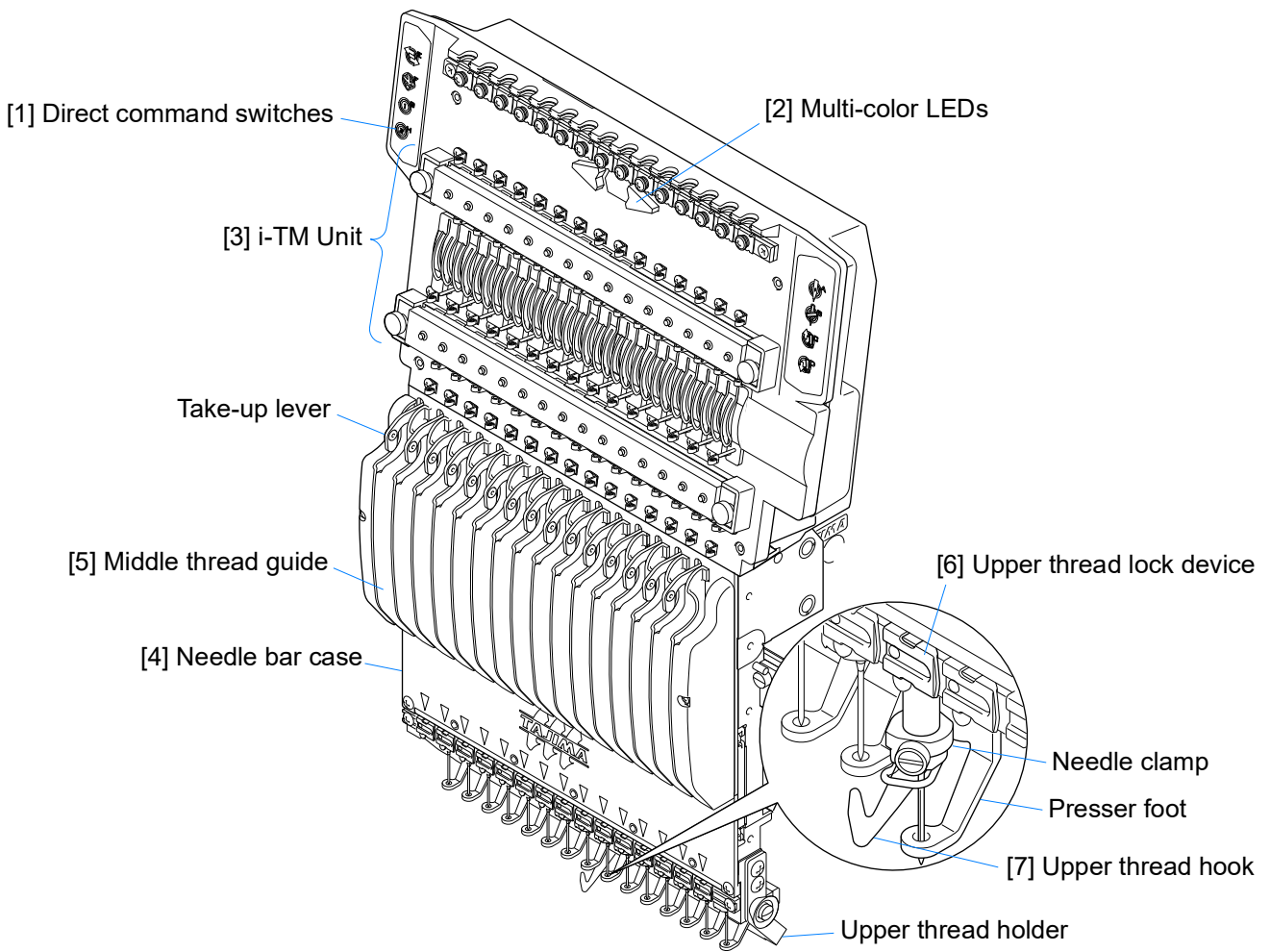

[1]	The switches for performing specific functions are provided. They allow you to perform specific functions without having to access the operation panel.	[4]	Slides laterally to align the selected needle to the sewing point.
		[5]	Absorbs the slack of the upper thread with the built-in thread take-up spring to stabilize the tension of the upper thread.
[2]	These LEDs turn ON or flash in various colors to indicate changes in status or the occurrence of thread breakage, etc.	[6]	Fixes or releases the upper thread appropriately during sewing.
[3]	Automatic adjustment of embroidery finish.	[7]	Hooks the upper thread after trimming so that the upper thread holder can retain it.



- Needles (needle bars) are numbered 1, 2, 3, and so on from the right to the left.

## 2-2. Rotary hook base, cylinder bed

### ■ Rotary hook base (flat type)

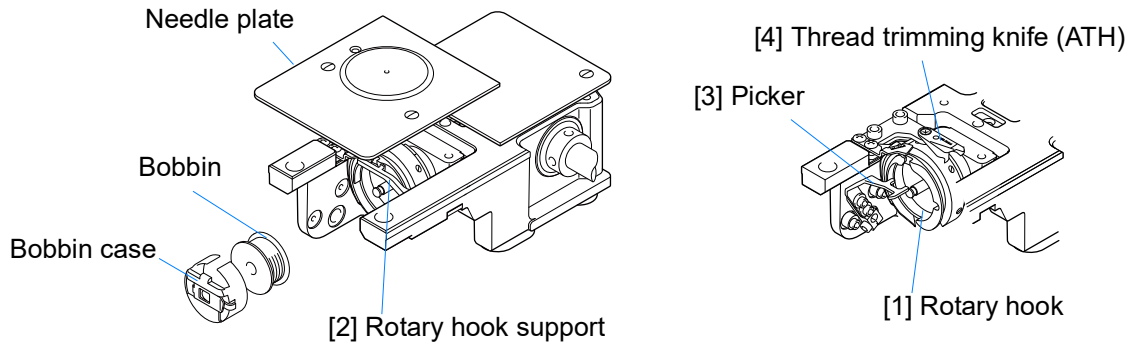

### ■ Cylinder bed (cylinder type)

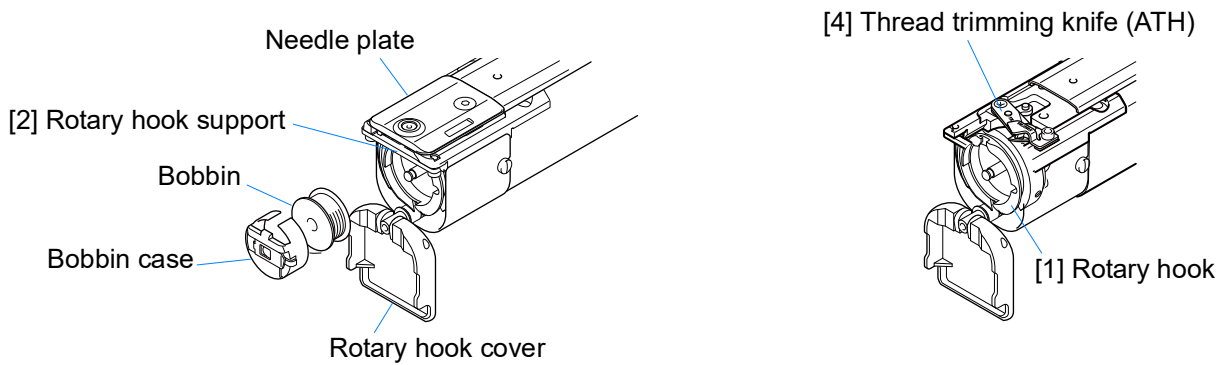

[1]	Vertical rotary hook (DB type). There are two types of rotary hook: “jumbo” and “regular”, and the winding amount of the lower thread is different each. Some models do not support the jumbo rotary hook. Also, the cylinder type machines support the regular rotary hook only.
[2]	Retains the inner hook to prevent it from rotating.
[3]	Prevents mis-stitching and adjusts the remaining length of the upper thread after thread trimming (Some models have no picker).
[4]	Cuts the upper and under threads after capturing them, consisting of the fixed and movable knives.

## 2-3. Operation panel



- The operation panel differs in specifications depending on model.

### ■ Touch panel type

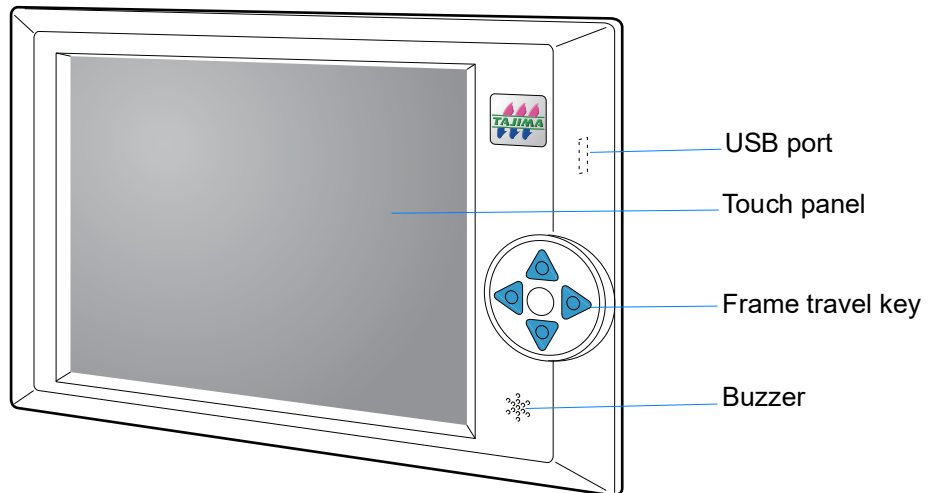

# Chapter 2 Needles

## 1. Usable Needles

Use needles developed exclusively for finishing on embroidery machines. Typical specifications of usable needles are shown below.

- Shank diameter [A]: 1.62 to 1.63 mm
- Butt to eye length [B]: 33.8 to 33.9 mm
- Length of shank [C]: 13.5 to 16 mm

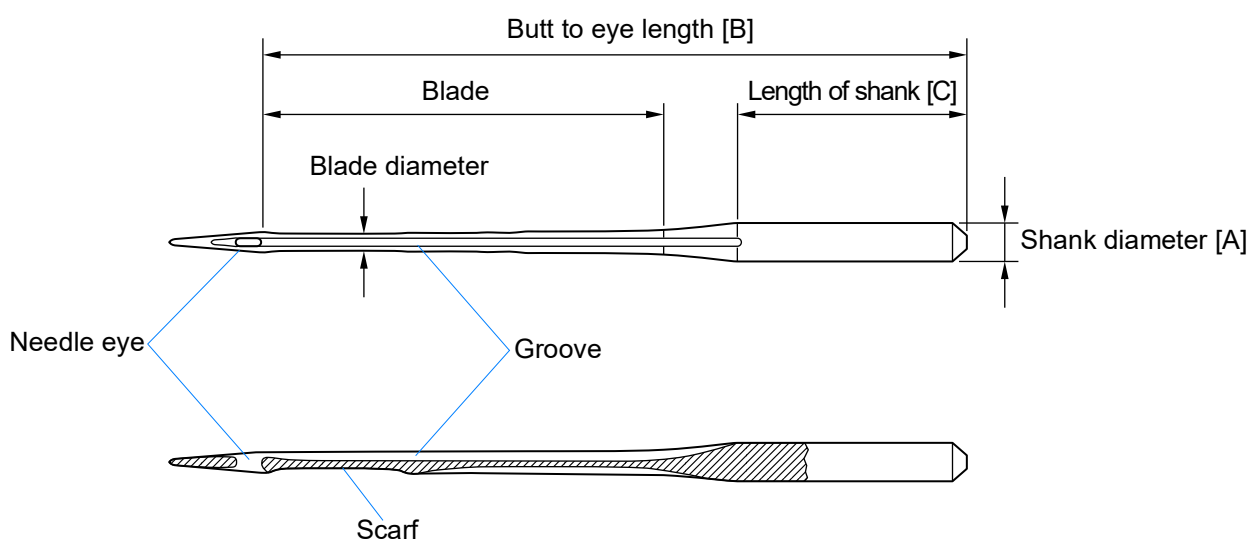

### 1-1. Standard needles

TAJIMA standard needles include the following.

Name	Manufacturer	Needle size	Length of shank [C]
DB x K5Z1	Manufactured by ORGAN	11 (75)	16 mm
DB x K5RG	Manufactured by GROZ-BECKERT	11 (75)	16 mm
DB x K5Z2	Manufactured by ORGAN	11 (75)	13.5 mm



- DBxK5Z2 is a standard needle applicable when using a cylindrical frame (an option). You can also use needles other than above depending on your needs. For details, consult the distributor.

### 1-2. Benefits of using standard needles

TAJIMA standard needles provide the following benefits.

- The tip of the needle is spherical and has excellent durability.
- It can be used for various purposes such as from thin to thick fabric, knit.
- It is effective to prevent the breakage of the thread and the needle.

## 2. Guidelines on Needle Selection

Select needles suitable for the threads and fabric material. Using a needle whose size and type are not suitable for the threads and fabric may result in imperfect stitches, broken threads, or skipped stitches.

### 2-1. Upper thread and needle compatibility list

Using the following compatibility list as a guide, select needles suitable for the embroidery thread size.

Embroidery thread type (d/2 = denier, two-piece twist)			Needle size	
Cotton (count number)	Polyester (d/2)	Rayon (d/2)	Japan	Germany
70 - 80	70 - 100	70 - 100	9	65
			10	70
50 - 60	100 - 130	100 - 130	11	75
			12	80
36 - 40	130 - 150	130 - 150	13	85
			14	90







- The cotton count number is expressed by the constant weight method (based on the thread length per unit weight). Therefore, the smaller the count number, the thicker the thread. On the other hand, the denier number of a polyester or rayon thread is expressed by the constant length method (based on the thread weight per unit length). Therefore, the larger the denier number, the thicker the thread.
- Thread count number (size) indications differ depending on the country/region and the manufacturer. For details, consult the distributor.

## 2-2. Variation of needle tip styles

There are a wide variation of needle pinpoint and tip styles. Use needle tip styles suitable for the fabric material and purpose.

The following table shows typical needle types with a ball-shaped tip.

Needle tip						
Mark	ORGAN	R	Q	J	B	U
	GROZ-BECKERT	R	RG	FFG	FG	G
Ball point size		Standard	Extra small	Small	Middle	Large



- Symbols differ depending on the country/region and the manufacturer. For details, consult the distributor.
- TAJIMA standard needles DB x K5Z1 and DB x K5Z2 use the extra small ball point (symbol Q).

## 3. Replacement of needle

This section describes the needle replacement procedure.

### 3-1. Needle replacement criteria

Needles are consumables. Using bad needles is likely to result in broken threads, broken needles, and skipped stitches. Therefore, replace needles with new ones or alternative ones with a proper count number if any of the following is true of them.

- The needle tip is worn off.
- The needle tip is broken.
- The blade is bent.
- Glue or other foreign matter is stuck on needle.
- The needle in use is not suitable for the thread and fabric types.

### 3-2. Checking if the needle is bent

Place the needle on a flat plane and try to roll it.

If the needle tip does not rotate evenly, it means that the blade is bent.

[Appropriate]

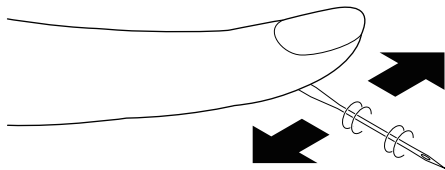

[Inappropriate]

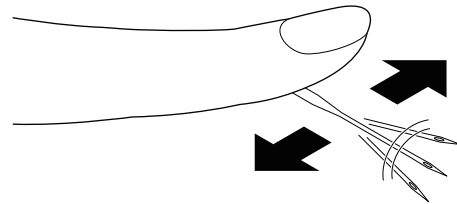

### 3-3. Needle Replacement

#### ⚠ Warning

! To prevent an accident due to an unexpected startup, be sure to turn OFF the power before accessing the machine.

#### ⚠ Caution

! Failure to correctly install the needle may result in breakage of the thread or needle.

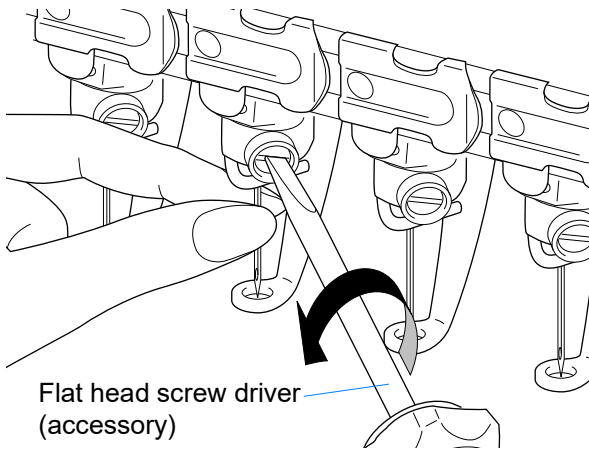

- 1 Loosen the screw with the supplied flat head screw driver while holding the needle by hand and then pull out the needle.



- Be sure to hold the needle by hand during replacement. Failure to observe this may cause the needle to fall down and enter into the needle hole.

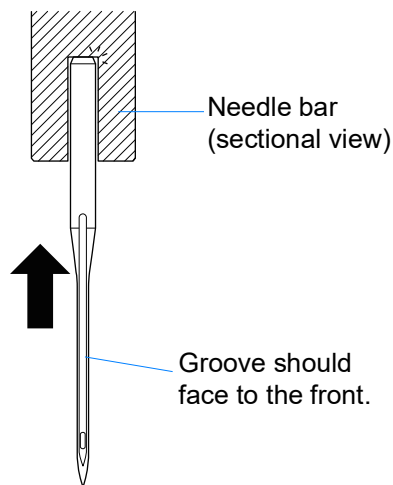

- 2 Insert the new needle into the needle bar until complete contact.
- 3 With the needle groove toward you, tighten the screw.

## Chapter 3

# Preparation of Threads

## 1. What Threads to Use

### 1-1. Upper threads

Among a wide variety of threads, it is common to use rayon threads (120d/2) or polyester threads (75d/2). For the upper threads, select the following embroidery threads.

#### ■ Twist type

##### [Two-piece twist (embroidery thread)]

This type of thread is mainly used for decoration purposes and has softness to emphasize brilliance and softness even if it overlaps.

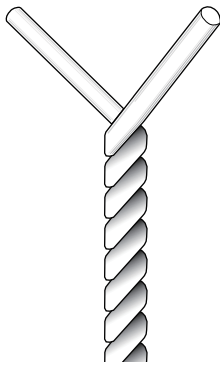

##### [Three-piece twist (embroidery thread)]

This type of thread is mainly used to sew the fabric pieces together and has enough strength.

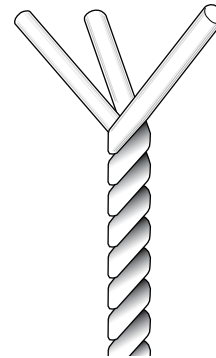

#### ■ Twist direction

Use left-twisted upper threads that fit to the rotating direction (counterclockwise) of the rotary hook. Right-twisted threads are poor in sewability because, for example, the thread filaments are easily separated.

##### [Appropriate: Left-twisted (Z-twisted)]

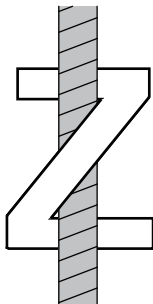

##### [Inappropriate: Right-twisted (S-twisted)]

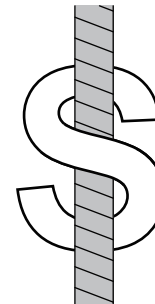

### ■ How to determine the twist direction

Twist the thread in the arrow direction. When thread twisting becomes looser, it is “left-twisted”. When thread twisting becomes stronger, it is “right-twisted”.

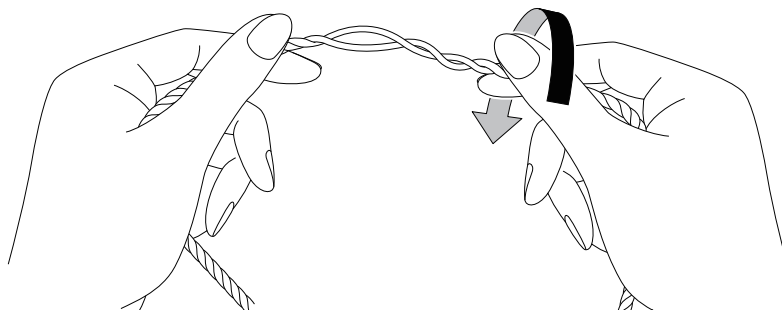

## 1-2. Under threads

It is common to use cotton or polyester spun threads as the under threads.

You are recommended to use a thin thread as much as possible (equivalent to count number 120) so that the back of the fabric will be finished softly.

### ■ Winding amount of under thread

Use a bobbin evenly wound with an appropriate amount of under thread.



- Using a bobbin wound with an excessive amount of thread or not evenly wound may result in thread breakage, biting, or bad finishing of sewing.

[Appropriate]

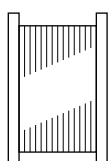

[Inappropriate]

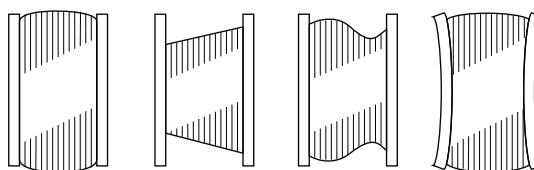

- The following are rough guidelines for determining that the bobbin is wound with an appropriate amount of thread.  
Bobbin for regular rotary hook: approx. 100 m  
Bobbin for jumbo rotary hook: approx. 180 m
- If the under thread is not evenly wound, it is necessary to adjust the under thread winder. For details, refer to the “Instruction Manual for the Under Thread Winder” supplied in a separate volume.

## 2. Setting the Upper Threads

### 2-1. Thread spool layout and threading positions

Avoid confusion about the thread spool layout and the threading positions, which differ from needle to needle. Note that the numbers in the figure show the needle (needle bar) numbers.

#### ■ Standard head, DCP head (Rotary tension base)

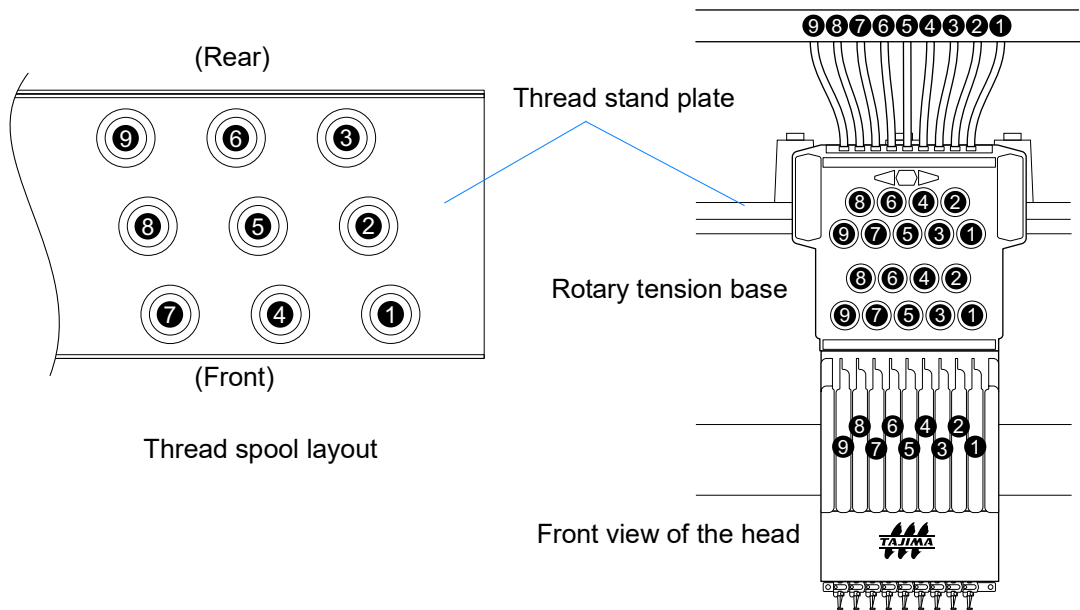

#### ■ i-TM head (i-TM tension base)

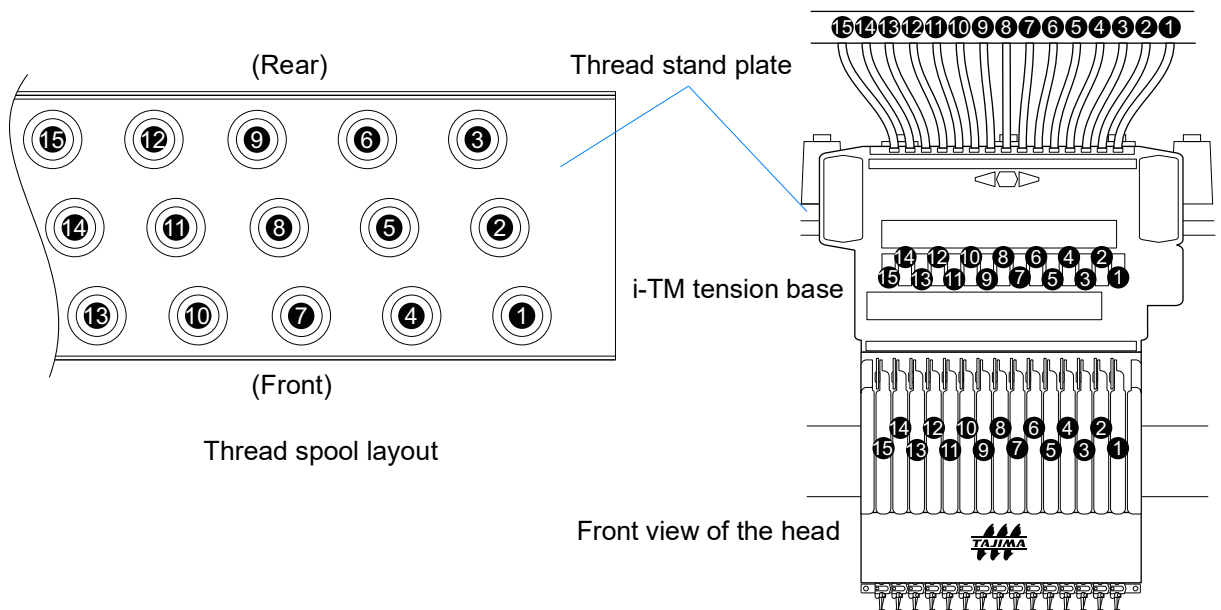

## 2-2. Setting the thread spools

Install the thread spools in the specified positions on the thread stand plate. When using a thread spool with a smaller hole, remove the thread stand blade. Lead the upper thread extending from the thread spool through each thread course.

### Warning



To prevent an accident due to an unexpected startup, ensure safety before accessing the machine. In addition, turn OFF the power if the work takes a long time.

### Caution



If you step on the table to perform the work, be sure to support the table using the supplied support. Otherwise, the table may be deformed.



When you step on the table to perform the work, do not stomp on the frame drive system, frame, etc. Otherwise damage may result.

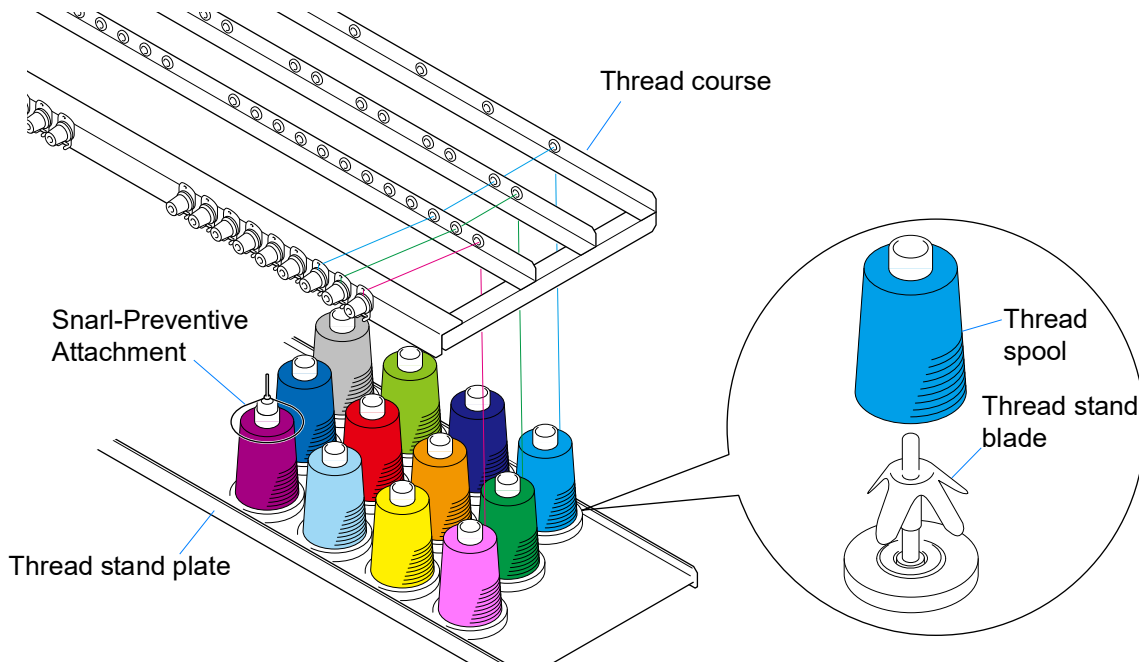

- The optional "Snarl-Preventive Attachment" effectively prevents the thread from snarling when it leaves the thread spool. Use the optional attachment as needed.
- For details, refer to the "Instruction Manual for the Snarl-Preventive Attachment" supplied in a separate volume.

## 2-3. How to pass the upper threads

After leading the upper threads through the thread course, pass them through the needles as described below.

### ⚠ Caution

! When passing the upper threads through the needles, take heed to the needle tips.

### ■ Standard head, DCP head

Shown below is an overview of the thread course. For details, refer to the corresponding steps on the following pages.

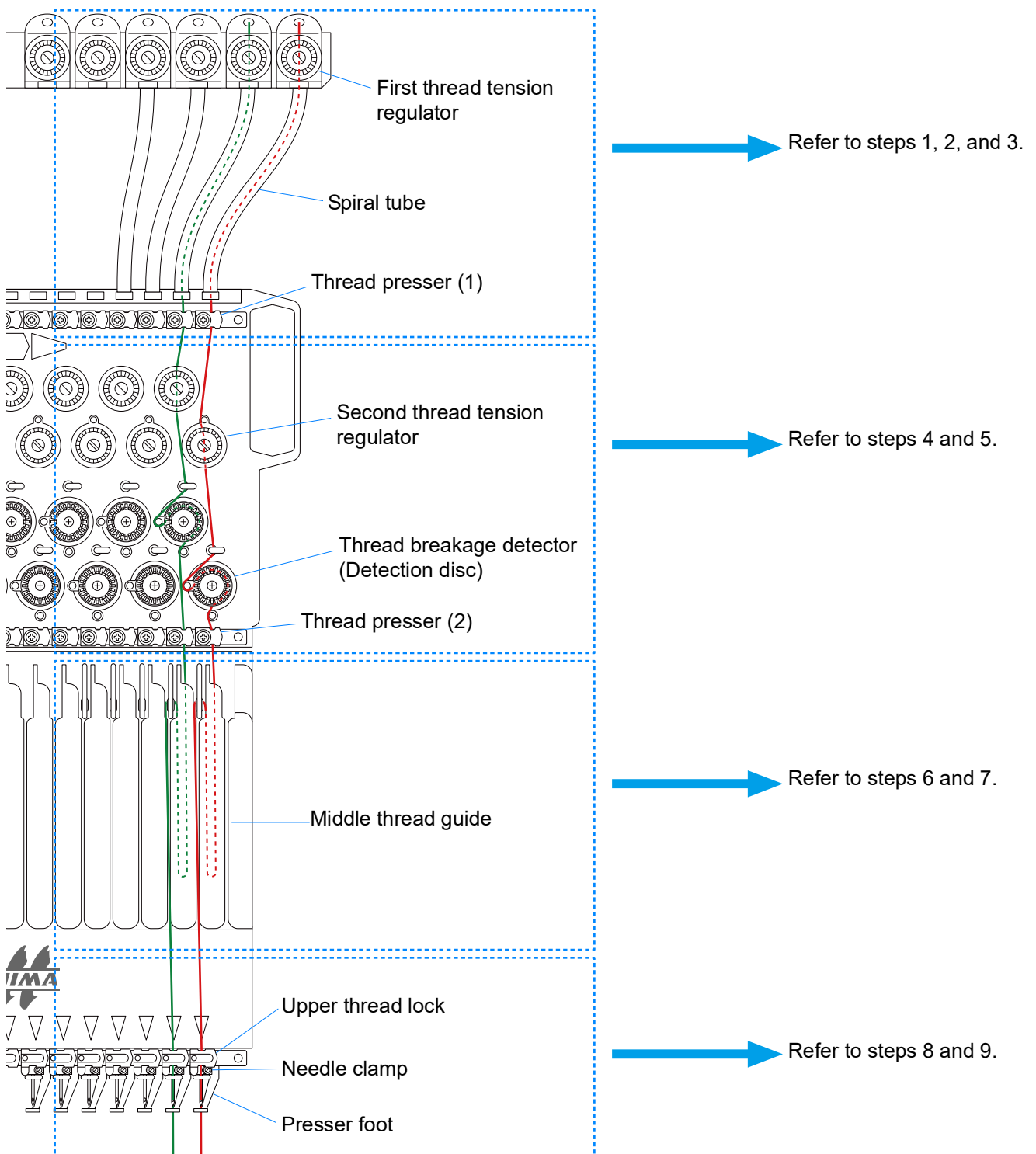

## 2. Setting the Upper Threads

The following are the details of the thread course (outlined on the previous page). Pass the upper threads as instructed.

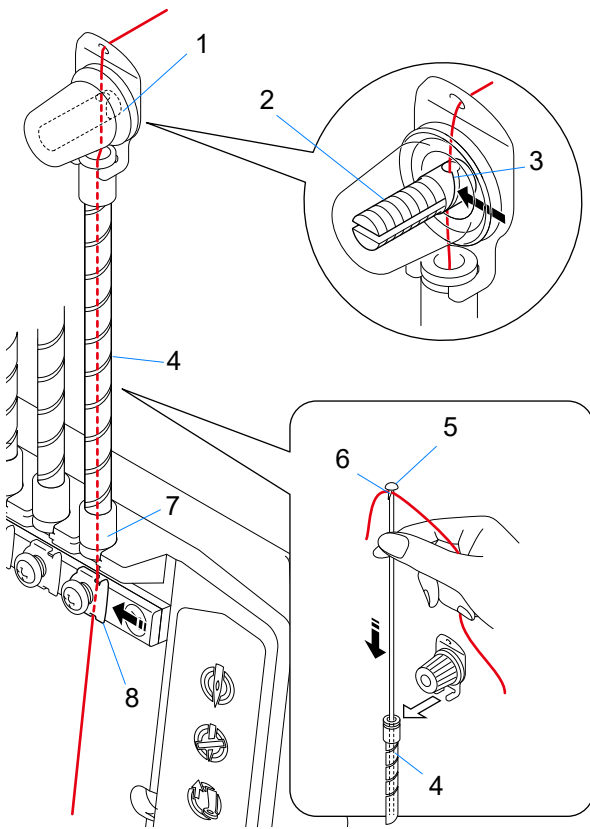

- 1 First thread tension regulator 1  
Pass the thread through the groove 3 of the tension stud 2.



- Otherwise, the upper thread may come off the thread tension regulator in the middle of embroidery.

- 2 Inside the spiral tube 4  
Hook the thread to the locking part 6 of the threader 5 (accessory) and insert it into the spiral tube 4. Pull the threader 5 out of the tube opening 7 fixed to the tension base and pass the thread through the spiral tube 4.

- 3 Thread presser 8  
Lift up the thread presser 8 by finger and pass the thread through the thread presser 8.

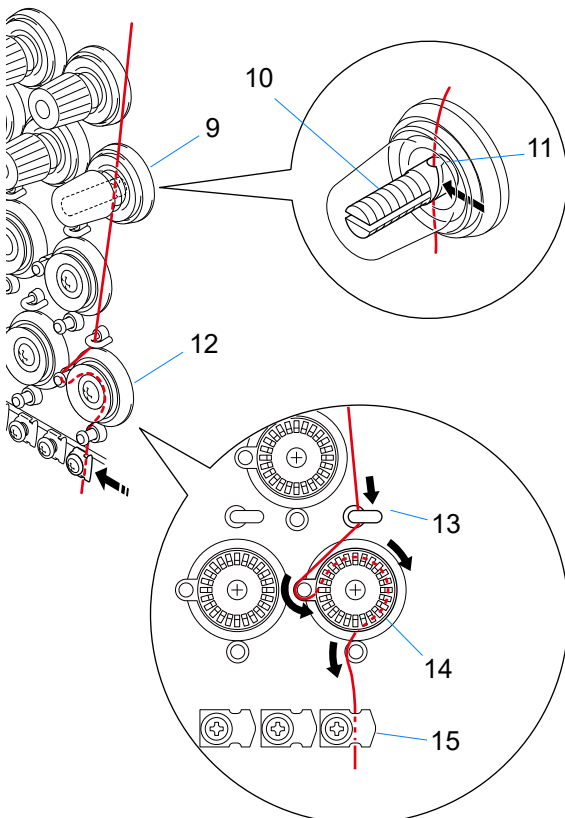

- 4 Second thread tension regulator 9  
Pass the thread through the groove 11 of the tension stud 10.



- Otherwise, the upper thread may come off the thread tension regulator in the middle of embroidery.

- 5 Thread breakage detector 12  
Pass the thread through the thread guide 13 and wind it clockwise around the detection disc 14 of the thread breakage detector 12.

- 6 Thread presser 15  
Lift up the thread presser 15 by finger and pass the thread through the thread presser 15.

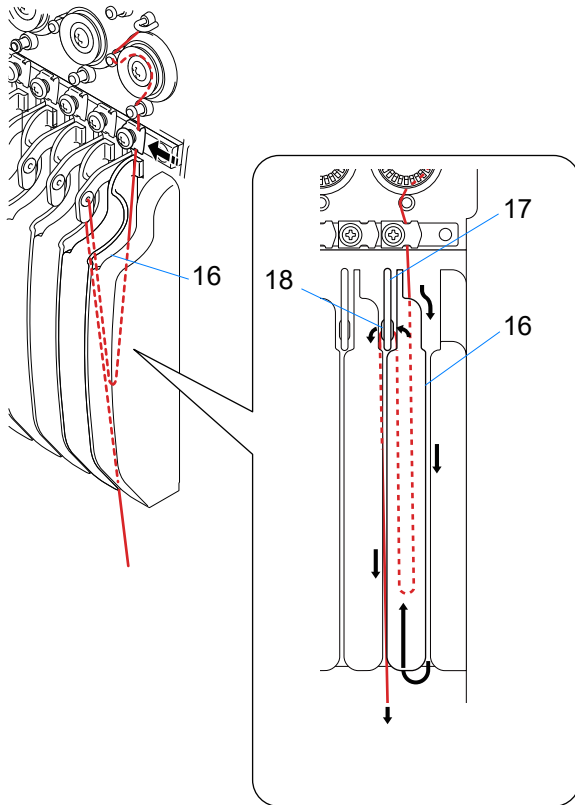

### 7 Middle thread guide 16

Hook the thread to the middle thread guide 16 of the needle bar case and pass it through the hole 18 in the take-up lever 17 from the right side.

How to pass threads correctly, please click the following URL to watch the video.

<https://tajima.box.com/s/ztmd5tkv1071214ztlke2wgdj0y4otn>

Video name: NOTICE ON PASSING THREADS.mp4

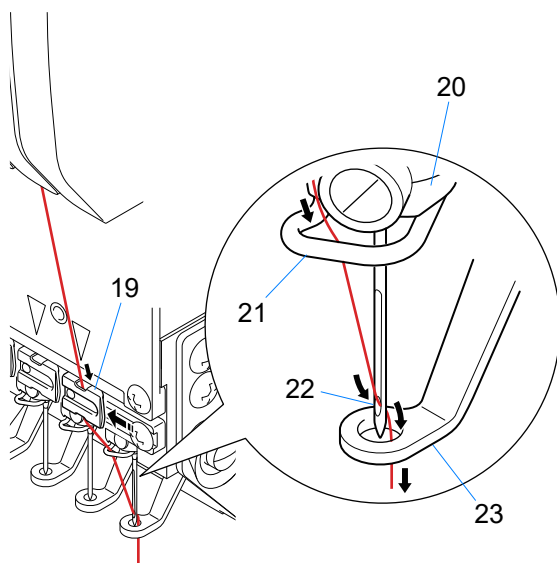

### 8 Upper thread lock 19

Lift up the upper thread lock 19 by finger and pass the thread through the upper thread lock 19.

### 9 Surrounding needle

Pass the thread through the thread holder 21 of the needle clamp 20 and then pass it through the needle hole 22 from front to rear.

Also, pass the thread through the hole in the presser foot 23 after passing it through the needle hole 22.

1

2

3

4

**i-TM head**

Shown below is an overview of the thread course. For details, refer to the corresponding steps on the following pages.

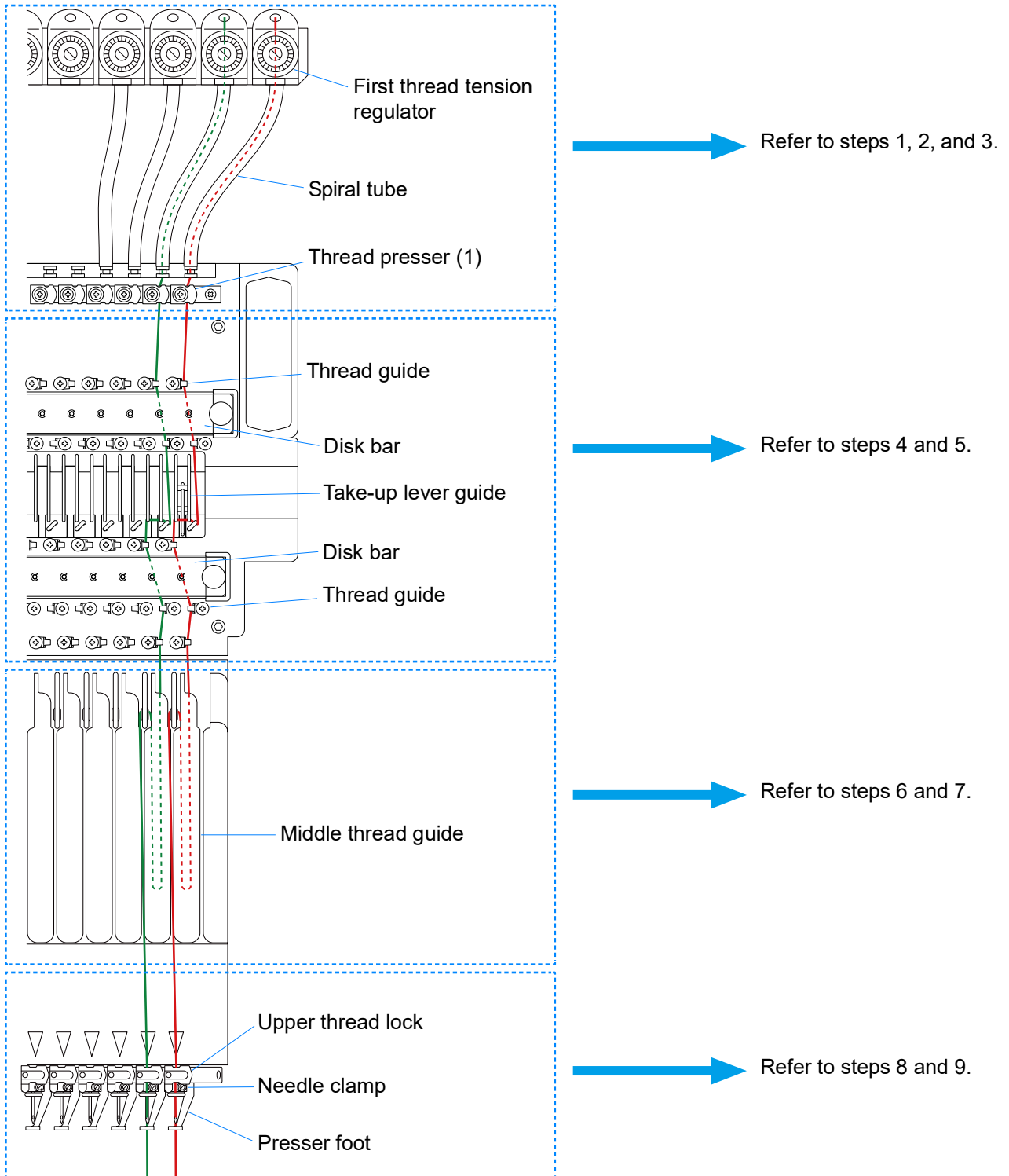

The following are the details of the thread course (outlined on the previous page). Pass the upper threads as instructed.

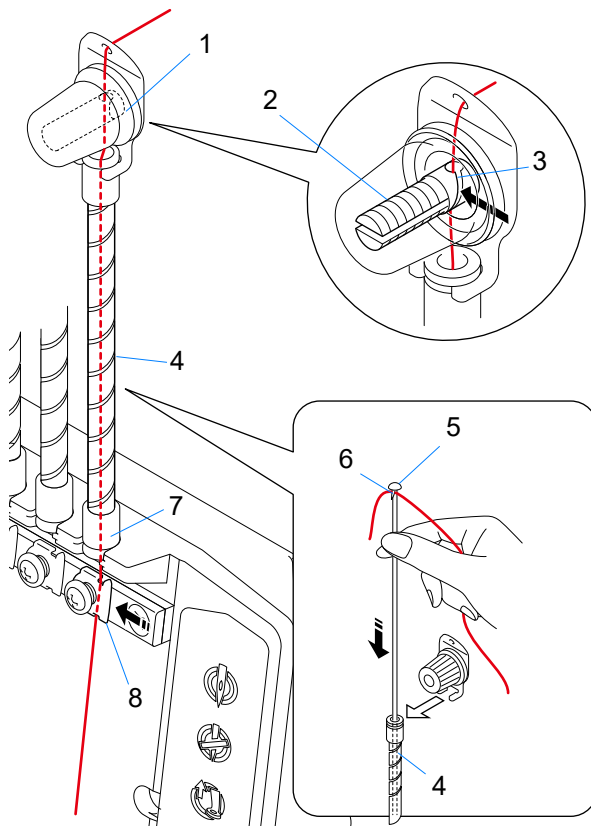

- 1 First thread tension regulator 1**  
Pass the thread through the groove 3 of the tension stud 2.



- Otherwise, the upper thread may come off the thread tension regulator in the middle of embroidery.

- 2 Inside the spiral tube 4**  
Hook the thread to the locking part 6 of the threader 5 (accessory) and insert it into the spiral tube 4. Pull the threader 5 out of the tube opening 7 fixed to the tension base and pass the thread through the spiral tube 4.

- 3 Thread presser 8**  
Lift up the thread presser 8 by finger and pass the thread through the thread presser 8.

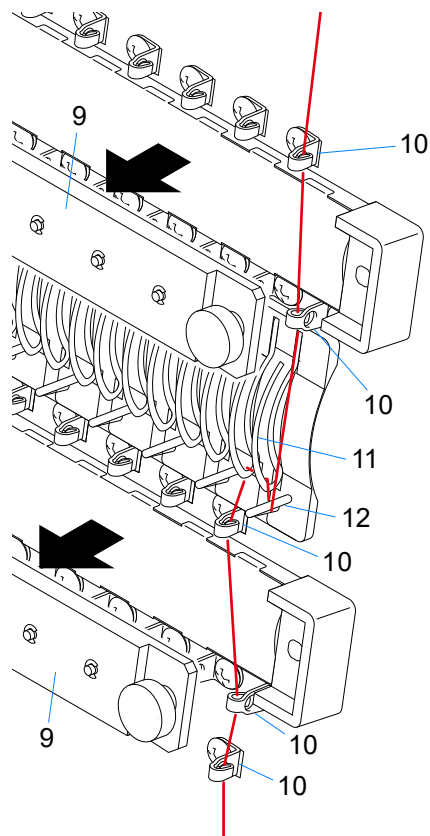

- 4 Disk bar 9 (upper and lower)**  
Remove disc bar 9 (upper and lower).



- Disc bars are magnetically attached. Grasp the knob and remove it.

- 5 Take-up lever guide 11**  
Pass the thread through the two thread guides 10 and then through the hook guide 12 to the take-up lever guide 11.

- 6 Lower disk bar 9**  
Pass the thread through the three thread guides 10.

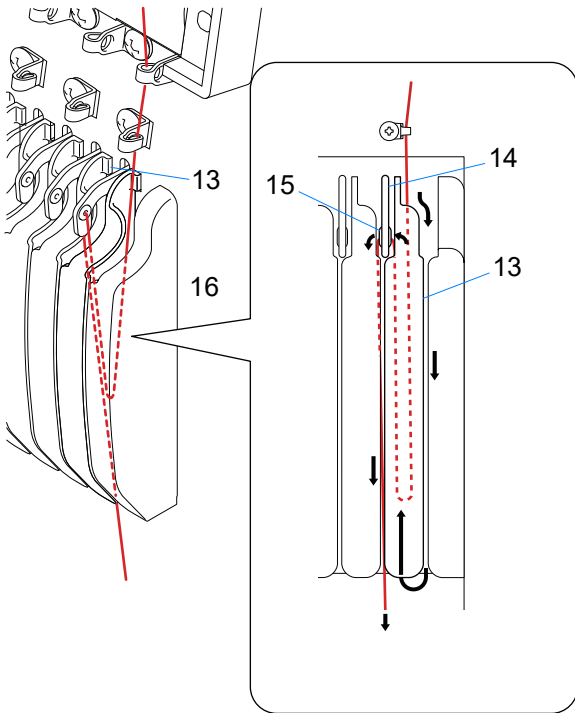

7 Middle thread guide 13

Hook the thread to the middle thread guide 13 of the needle bar case and pass it through the hole 15 in the take-up lever 14 from the right side.

How to pass threads correctly, please click the following URL to watch the video.

<https://tajima.box.com/s/ztmd5tkv107l214ztlke2wgdj0y4otn>

Video name: NOTICE ON PASSING THREADS.mp4

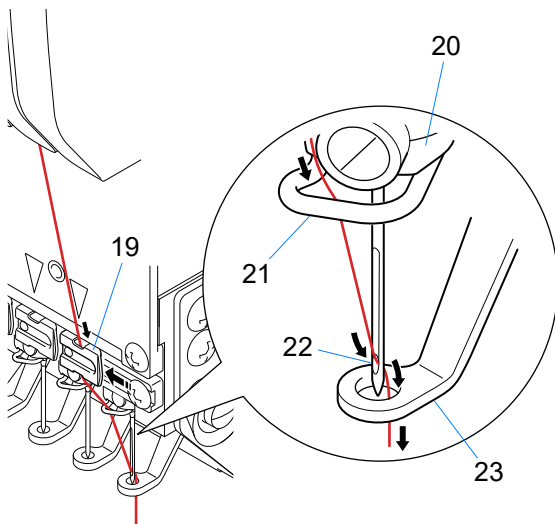

8 Upper thread lock 19

Lift up the upper thread lock 19 by finger and pass the thread through the upper thread lock 19.

9 Surrounding needle

Pass the thread through the thread holder 21 of the needle clamp 20 and then pass it through the needle hole 22 from front to rear.

Also, pass the thread through the hole in the presser foot 23 after passing it through the needle hole 22.

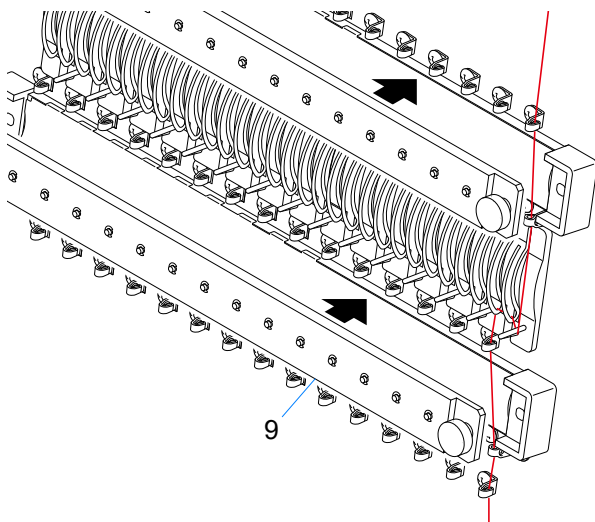

10 Disk bar

When all the threads have passed through, set the disk bars 9 ( upper and lower ) for the last time.



- Disk bar can be installed without any problem even if the upper and lower rows and left and right sides are interchanged.

## 3. Setting the Under Threads

### 3-1. How to set the bobbin to the bobbin case

Set the bobbin to the bobbin case after winding it with the under thread.



- Do not use a bobbin case whose thread guide coil or thread presser spring is damaged. In addition, if a bobbin case is damaged during use, immediately replace it with new one. Otherwise defective sewing may result.

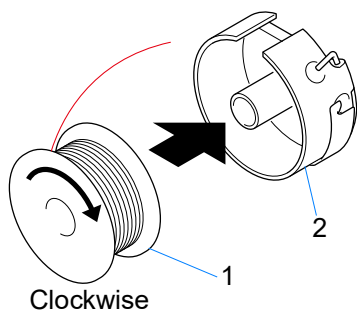

- 1 Orient the bobbin 1 so that the under thread winding direction is clockwise and then insert it into the bobbin case 2.



- Failure to observe this may result in defective sewing.

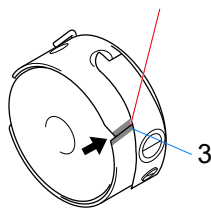

- 2 Pass the under thread through the slit 3 in the bobbin case 2.

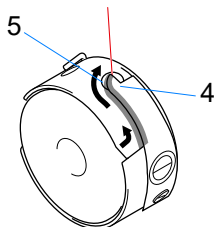

- 3 Directly slide the under thread to the spring edge 4 and lead it to the hole 5.

[In case of coil type]  
Wind the thread twice and pass it through the coil.

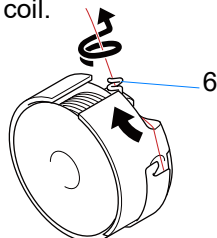

- 4 Adjust the under thread tension.



- For information on how to adjust the under thread tension, refer to "Chapter 3 4-2. Adjusting the under thread tension" >>P.31.

[In case of L-shape type]  
Pass the thread through the thread guide.

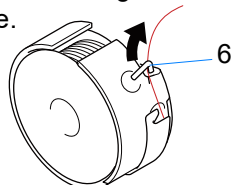

- 5 Pass the thread through the thread guide 6.

## 3-2. How to set the bobbin case to the rotary hook

### Warning



To prevent an accident due to an unexpected startup, ensure safety before accessing the machine. In addition, turn OFF the power if the work takes a long time.

When replacing the under thread, detach the bobbin case from the rotary hook.

The following example shows the replacement procedure, assuming that your machine is the flat type.



- If your machine is the cylinder type, open/close the rotary hook cover when replacing the bobbin case.

### ■ Removal from the rotary hook

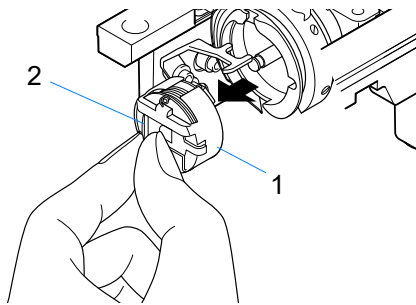

- 1 Take out the bobbin case 1 from the rotary hook while pinching the latch 2 of the bobbin case 1.

### ■ Installation to the rotary hook

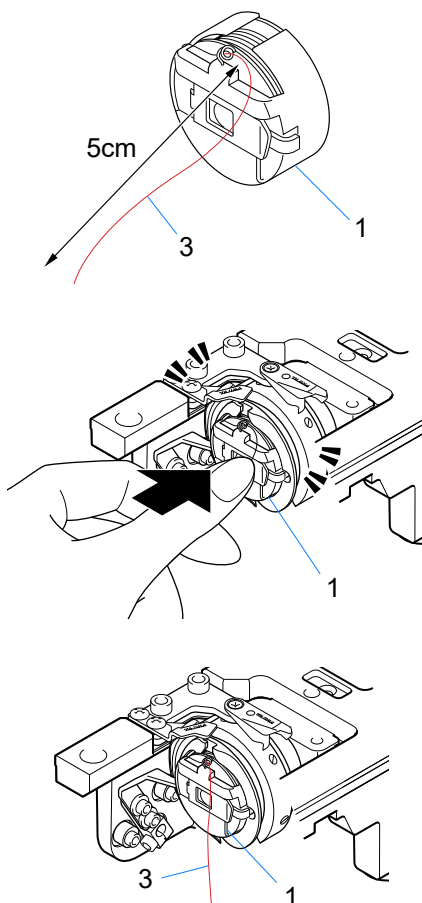

- 1 Pull the under thread 3 approx. 5 cm out of the bobbin case 1.
- 2 Press the bobbin case 1 into the rotary hook until you hear a “click” sound.
- 3 Let down the pulled out portion of the under thread 3 on the front side of the bobbin case 1.

## 4. Adjustment of thread tension

Adjust the thread tension properly upon thread replacement or whenever deemed necessary to improve the finishing of sewing.



- For more information on the measuring gauges for thread tension adjustment (TAJIMA UTG and BTG are recommended), refer to the instruction manual that comes with the product.

### 4-1. Adjusting the upper thread tension (Standard head, DCP head)

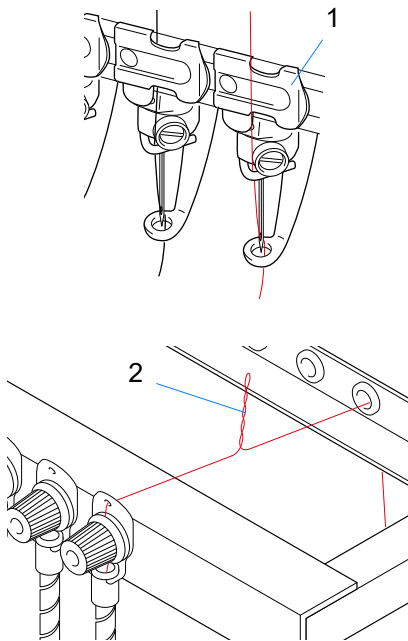

- 1 Release the upper thread from the upper thread lock 1.



- With the upper thread locked, you cannot measure the tension correctly.

- 2 Pull the upper thread out of the needle tip and remove the snarl 2 of the upper thread on the thread course.

1

2

3

4

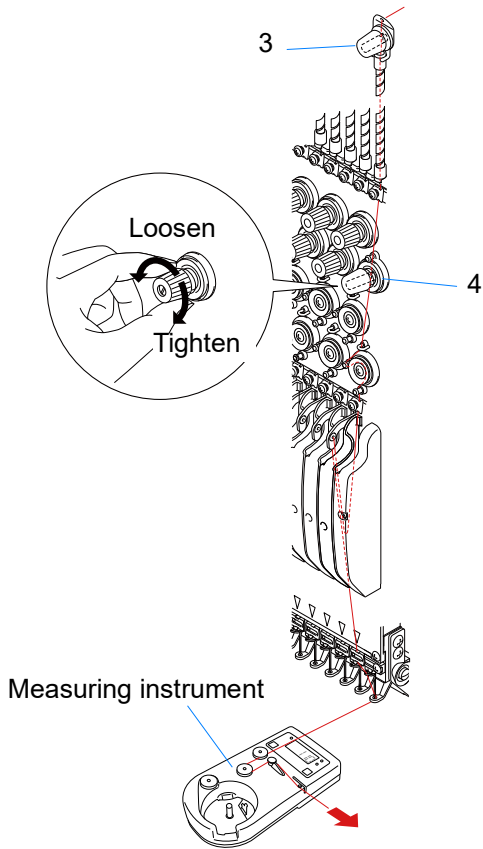

- 3 By turning the adjustment knob of the first thread tension regulator 3, tense the upper thread slightly to remove its slack.
- 4 While pulling out the upper thread passed through the measuring instrument, adjust the adjustment knob of the second thread tension regulator 4 so that the upper thread tension falls within the standard range.
  - To decrease the tension, loosen the adjustment knob (by turning it counterclockwise).
  - To increase the tension, tighten the adjustment knob (by turning it clockwise).

Thread	(d/2)	Tension value (g)
Rayon	120	110 - 130
Polyester	120	100 - 110



- The optimum tension value differs depending on the fabric, the needle and thread types, and other factors. Fine-tune the tension while checking the finishing of sewing.

## 4-2. Adjusting the under thread tension

### ■ Checking the tension

With passing the under thread through the bobbin's thread guide (for both the coil and L-shape types), measure the tension with the measuring gauge.

- Under thread tension standard range (rough guideline): 30 to 35 g

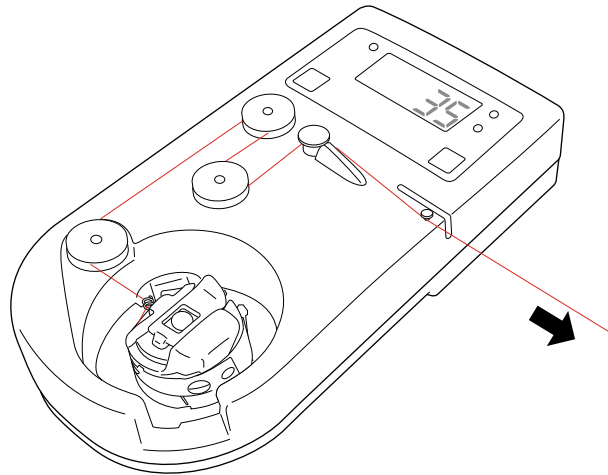

### ■ Adjusting the tension

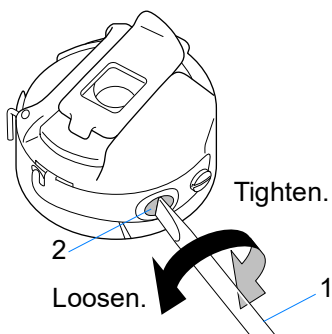

- 1 Adjust the tension by turning the tension adjusting screw 2 with the flat head screw driver 1 (accessory).
  - To decrease the tension, loosen the screw.
  - To increase the tension, tighten the screw.

# Chapter 4

## Fabric Stretching

### 1. How to Stretch the Fabric on the Border Frame

#### 1-1. How to use the clips

Use the supplied clips when stretching fabric on the border frame. Clip the fabric between the clips and the holding section of the border frame to fasten the fabric.

The clip shape and how to attach/detach the clips differ depending on the spec. of the border frame.

[If the spec. of the border frame sash is BFF4 or BFF6]

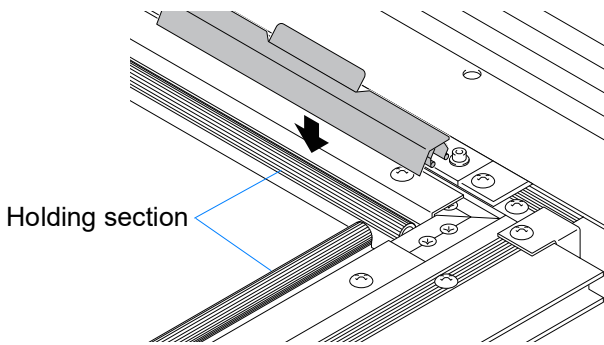

Attaching

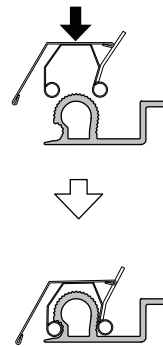

Detaching

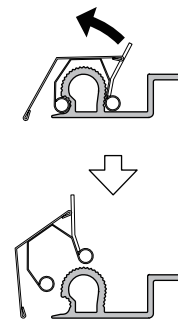

[If the spec. of the border frame sash is BFF8]

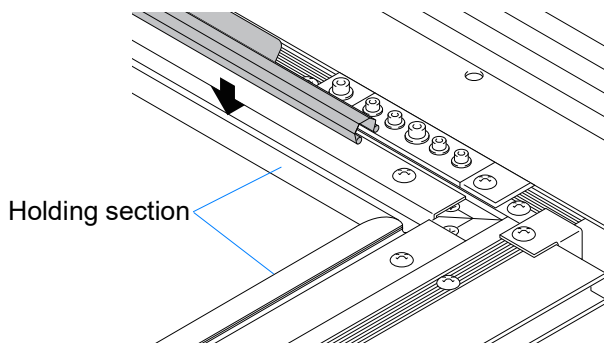

Attaching

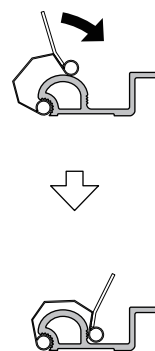

Detaching

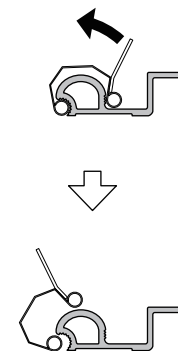

**⚠ Caution**

- ⊘ If you are using the border frame sash type BFF8 on a machine of a table cut spec., do not attach clips to the cut section. Clips attached to the cut section are likely to be misaligned. If the frame is moved with clips misaligned, the table will be damaged.

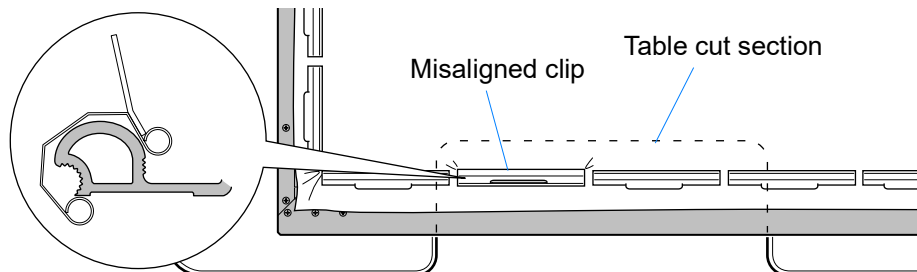
**1-2. How to stretch the fabric**

Alternately fasten each side of the fabric to the border frame.

**⚠ Warning**

- ! To prevent an accident due to an unexpected startup, be sure to turn OFF the power before accessing the machine.



- Attach the clips with even spacing between them.
- If the fabric is much elastic, thin, or coarse, lay a puckering preventive sheet (such as an unwoven cloth) under the fabric before stretching it to the border frame.
- For information on how to prevent fabric puckering, refer to "Chapter 4 3. Preventing Fabric Puckering" >>P.38.
- Do not forcibly pull the fabric if it is much elastic.

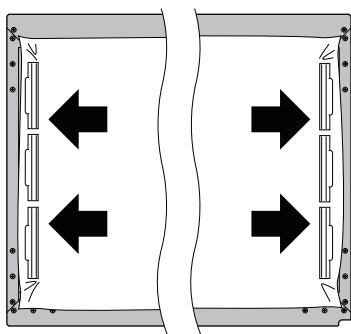

- 1 Fasten either the left or right side of the fabric (the right side in this example).
- 2 Fasten the other side (the left side in this example) while pulling the fabric outward.

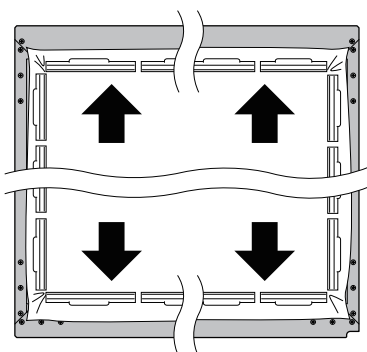

- 3 Fasten the front and rear sides, similarly to the above.



- If the fabric is still wrinkled, temporarily detach the clips adjacent to the wrinkled portion and remove the wrinkles.

## 2. How to Stretch the Fabric on the Tubular Goods Frame

### 2-1. What frame to use

Use a tubular goods frame that matches the size of the embroidery design.



- Using a frame unnecessarily larger than the design may result in a high likelihood of displacement due to fabric puckering or bad finishing of sewing.

#### ■ Good and bad examples

[Appropriate]

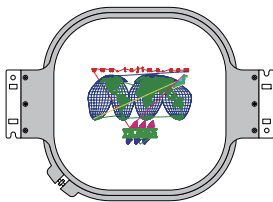

[Inappropriate]

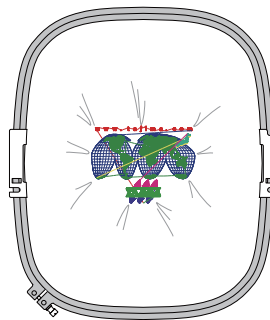

Frame is too large

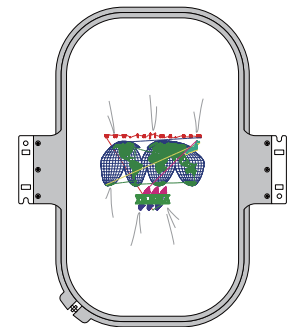

Frame is too large vertically or horizontally

## 2-2. How to stretch the fabric

Place the frame on a table or other flat surface to stretch the fabric.

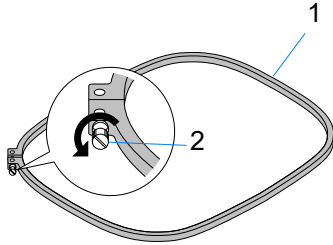

- 1 Loosen the adjustment screw 2 of the outer frame 1.

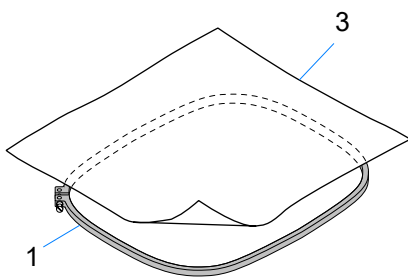

- 2 Place the fabric 3 on the outer frame 1.



- If the fabric is much elastic, lay a puckering preventive sheet (such as an unwoven cloth) under the fabric before stretching it to the tubular goods frame.
- For information on how to prevent fabric puckering, refer to "Chapter 4 3. Preventing Fabric Puckering" >>P.38.

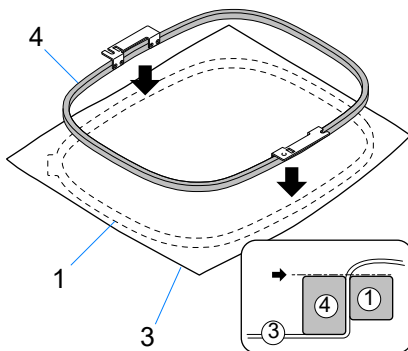

- 3 Fit the inner frame 4 inside.  
Press in the inner frame 4 until it becomes almost flush with the outer frame 1.

1

2

3

4

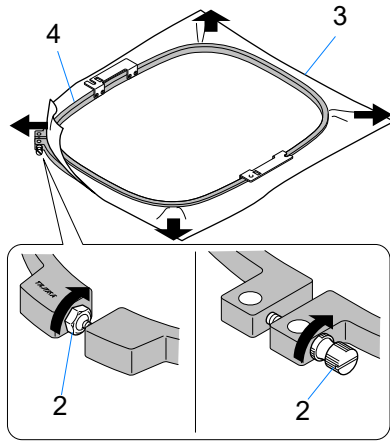

- Slightly tighten the adjustment screw 2 of the outer frame 1 and pull the fabric 3 within the frame to remove the slack.



- Pull it to the extent that the fabric features (such as weave and knit patterns) are not distorted. Also, do not forcibly pull the fabric if it is much elastic.

- Tighten the adjustment screw 2 of the outer frame 1.

### ⚠ Caution



Use a spanner or flat head screw driver to tighten the adjustment screw but do not excessively tighten it. Otherwise the adjustment screw or the frame itself may be broken.

## 2-3. Using tubular goods gauge frame sets

For embroidery on the chest or sleeves of a cloth such as sweat shirt or T-shirt, the tubular goods gauge frame set (including the front body base and the arm base) is available as an option. This frame set allows you to always fit the frame in the same position, making it easy to position the frame.

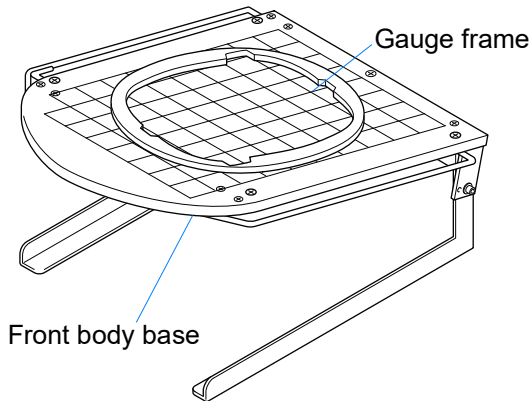

- Prepare a gauge frame that matches the size of the tubular goods frame. For details, consult the distributor.

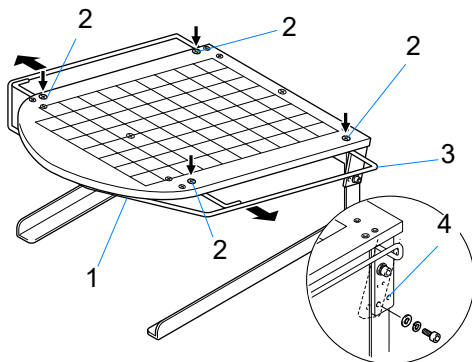

- Loosen the four screws 2 of the front body base 1 and adjust the position of the arm 3 to match the width of the cloth.



- To change the angle of the front body base, use a different screw fixing hole 4.

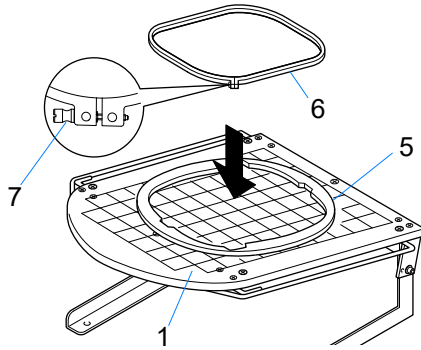

- 2 Using the guidelines on the front body base 1, fasten the gauge frame 5 with a double-side tape, etc.
- 3 Loosen the adjustment screw 7 of the outer frame 6 and fit the outer frame into the gauge frame 5.



- If the fabric is much elastic, lay a puckering preventive sheet (such as an unwoven cloth) on the outer frame before stretching it to the tubular goods frame.
- For information on how to prevent fabric puckering, refer to "Chapter 4 3. Preventing Fabric Puckering" >>P.38.

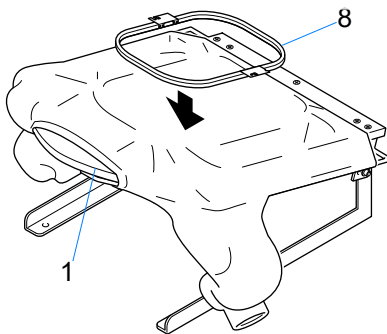

- 4 Lay the embroidery face of the cloth over the front body base 1 and align it.
- 5 Similarly, fit the inner frame 8 into the outer frame 6 with reference to "Chapter 4 2-2. How to stretch the fabric" >>P.35.
- 6 Lift up the tubular goods frame and detach it from the gauge frame 5. Pull the cloth out of the front body base 1.

# 3. Preventing Fabric Puckering

If the fabric, such as knit, is much elastic, thin, or coarse, you can minimize the puckering of the fabric due to embroidery and the distortion of patterns by laying a puckering preventive sheet (such as an unwoven cloth) under the fabric.

## 3-1. Guidelines on sheet selection

Determine the type, thickness, and number of sheets you should use, taking into account the fabric material, the appearance of embroidery, the finished hardness, etc.

Type	Characteristic
<b>Oil paper</b>	<ul style="list-style-type: none"> <li>• Oil paper such as paraffin paper and wax paper is manufactured by thinly coating paper with oil and drying it.</li> <li>• It improves the smoothness of thread and needle movement. Particularly when you use threads poor in smoothness, oil paper is effective in preventing broken threads.</li> <li>• Wax paper is commonly used for embroidery on leather or applique.</li> </ul>
<b>Unwoven cloth</b>	<ul style="list-style-type: none"> <li>• An unwoven cloth has high stiffness and is most effective in preventing the puckering of the fabric.</li> <li>• Its high stiffness makes the finished hardness higher than other types of sheet.</li> <li>• Use an unwoven cloth that can be torn vertically and horizontally.</li> <li>• Water soluble unwoven cloths are also available. "Water soluble" means that they solve in water or hot water. Therefore they will not remain on the backside.</li> </ul>
<b>Film</b>	<ul style="list-style-type: none"> <li>• Films can be removed by heat, making the post-processing easy.</li> <li>• Their softness provides a flexible feel.</li> <li>• Water soluble films are also available. "Water soluble" means that they solve in water or hot water. Therefore they will not remain on the backside.</li> </ul>

## 3-2. How to use sheets

You can use the sheets in two ways.

**[Stretch on the frame together with the fabric]**

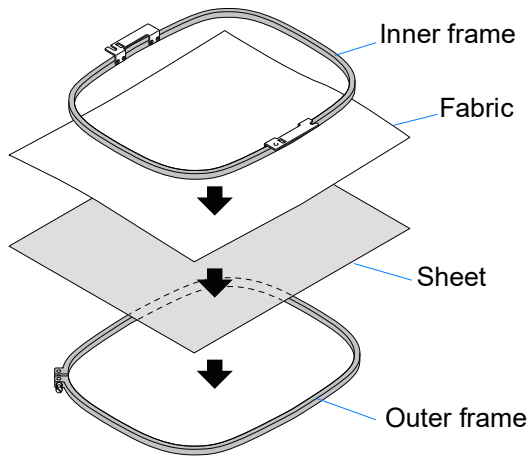

**[Lay under the fabric]**

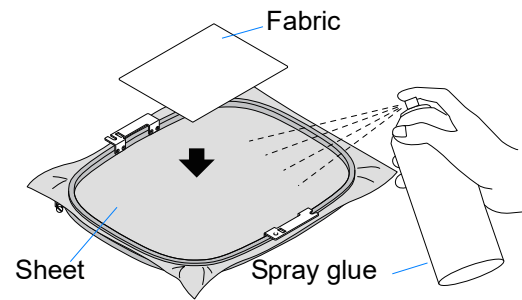

- Use this method when you do not want the fabric dented under the frame.
- To prevent misalignment, bond the fabric with spray glue.

1

2

3

4

## 4. How to use the middle sash (accessory)

Attaching the middle sash to the border frame allows you to change the border frame spacing in the lengthwise direction (the Y direction) according to the width of the fabric, the embroidery space, and the type of the frame. When using the middle sash, install the middle sash stays (hereinafter “stays”) between the border frame and the middle sash to prevent the middle sash from slacking.



- The middle sash does not come with some models.

### ■ Example of Usage

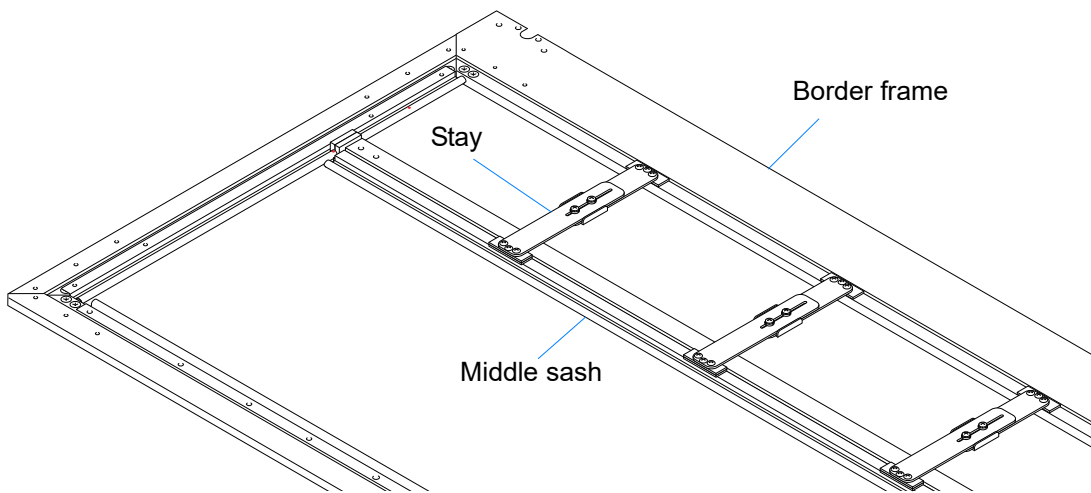

### 4-1. About stays

Stays are available in six types, A to F, which differ in overall length. In addition, you can combine different stay types to change the overall length. Use them appropriately according to the embroidery space in the Y direction and the type of the frame.



- The number and type of the stays that come with the machine differ depending on the spec. of the machine and the number of drives in the Y direction.  
For more information, refer to "Chapter 4 4-4. Quantity of stays and breakdown of accessories" >>P.46.

A	162mm
B	249mm
C	326mm
D	420mm
E	545mm
F	715mm

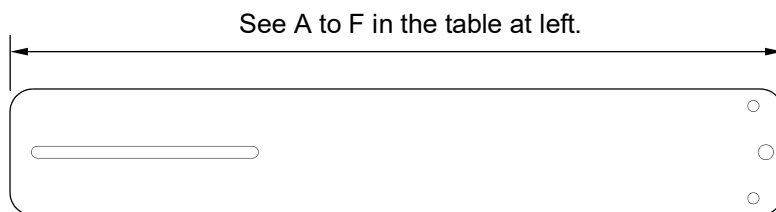

## ■ Selecting the stay type(s)

Based on the dimension (a) in the figure above, select the stay type (A to F). When using combinations of two stay types, combine stay types (A to F) with reference to the table below.

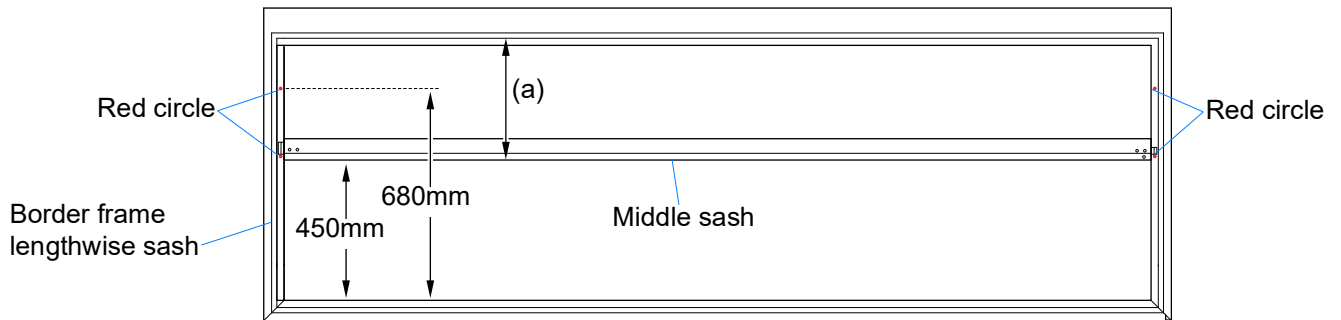

Stay	Dimension (a)	Stay	Dimension (a)	Stay	Dimension (a)
A+A	164 - 264 mm	B+C	415 - 515 mm	C+F	861 - 981 mm
A+B	251 - 351 mm	B+D	509 - 609 mm	D+D	680 - 780 mm
A+C	328 - 428 mm	B+E	634 - 734 mm	D+E	805 - 905 mm
A+D	422 - 522 mm	B+F	784 - 904 mm	D+F	955 - 1075 mm
A+E	547 - 647 mm	C+C	492 - 592 mm	E+E	930 - 1030 mm
A+F	697 - 817 mm	C+D	586 - 686 mm	E+F	1080 - 1200 mm
B+B	338 - 438 mm	C+E	711 - 811 mm	F+F	1230 - 1370 mm



- For the machines with the Y-directional embroidery space of 750 mm or greater, there are two red circles on the border frame lengthwise sash. If you install the middle sash in the position marked by one of the two red circles, the Y-directional embroidery space will be 680 mm or 450 mm. Use the red circles as rough guidelines when installing the middle sash.

## 4-2. Installation method (when using the one-touch frame)

### Warning

 To prevent an accident due to an unexpected startup, be sure to turn OFF the power before accessing the machine.

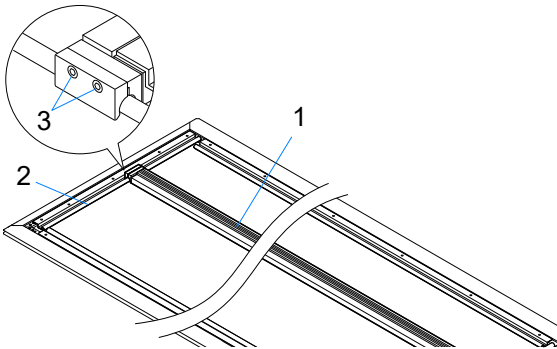

- 1 Install the middle sash 1 lengthwise across the border frame lengthwise sash 2 in the position that matches the size of the one-touch frame you will use, and tighten the screws 3.



- The procedure after this differs depending on whether you use one-piece or two-piece stays.

### When using one stay

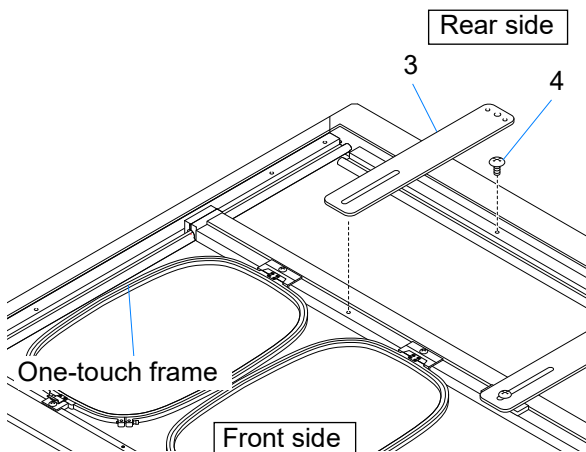

- 1 Remove the border frame screw 4 in the installation position of the stay 3.

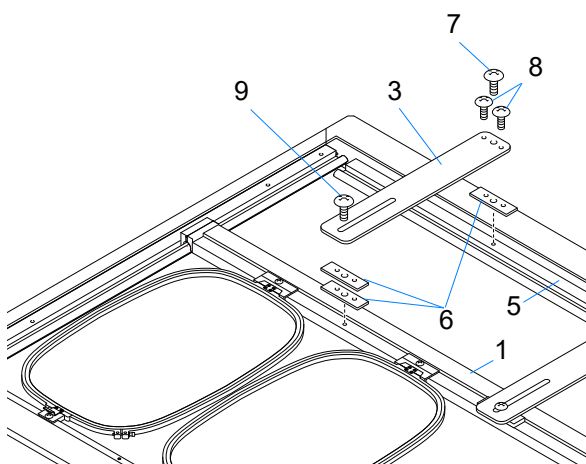

- 2 Place the specified number of spacers 6 (two for the front side and one for the rear side) on the face on which the border frame crosswise sash 5 is installed and the upper face of the middle sash 1.
- 3 Install the stay 3 over the spacers 6 on both sides and fasten the rear side of the stay 3 with the truss head screw 7 (JIS M4x12) and the truss head screws 8 (M3x5).
- 4 Fasten the front side of the stay 3 with the truss head screw 9 (JIS M4x12).



- You may pull the stay front end toward you to the extent that it does not interfere with the one-touch frame or does not hinder embroidery.

## ■ When using two stays in set

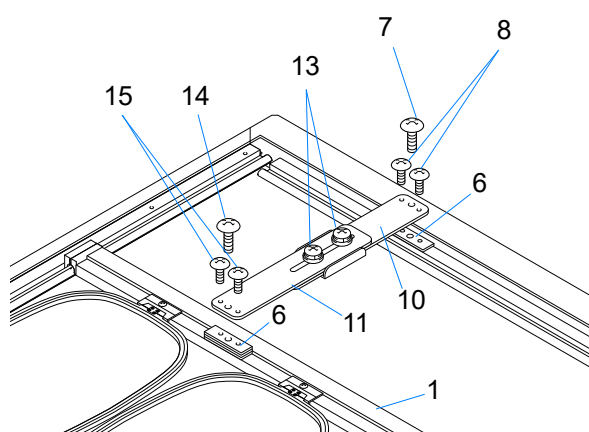
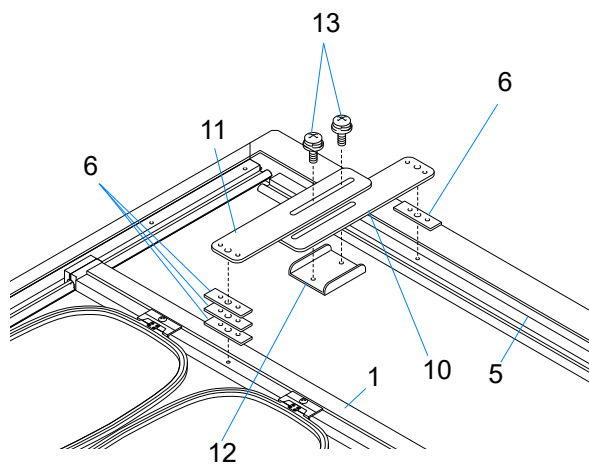
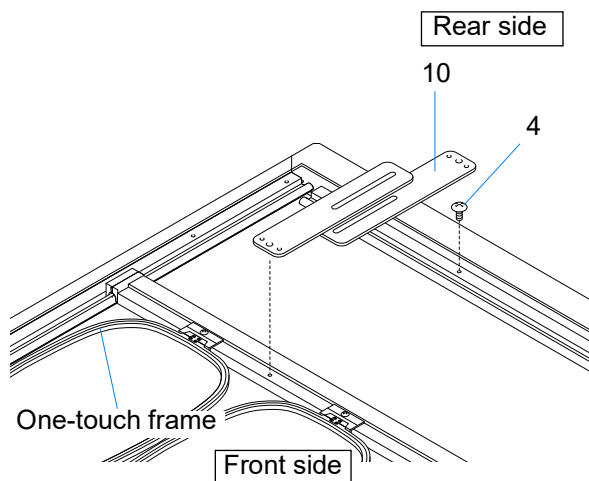

- 1 Remove the border frame screw 4 in the installation position of the stay 10 (rear side).
- 2 Place the specified number of spacers 6 (three for the front side and one for the rear side) on the face on which the border frame crosswise sash 5 is installed and the upper face of the middle sash 1.
- 3 Place the stay 11 (front-side) over the stay 10 (rear-side), couple them using the joint 12, and temporarily tighten the screws with washers 13 (M4x12).
- 4 Install the coupled stays 10 and 11 over the spacers 6 on both sides and fasten the stay 10 (rear side) with the truss head screw 7 (JIS M4x12) and the truss head screws 8 (JIS M3x5).
- 5 Slide lengthwise the stay 11 (front-side) to align it to the middle sash 1 and fasten it with the truss head screw 14 (JIS M4x12) and the truss head screws 15 (M3x5).
- 6 Fasten the screws with washers 13 (M4x12) you temporarily tightened in step 3.

### 4-3. Installation method (when not using the one-touch frame)

#### Warning

 To prevent an accident due to an unexpected startup, be sure to turn OFF the power before accessing the machine.

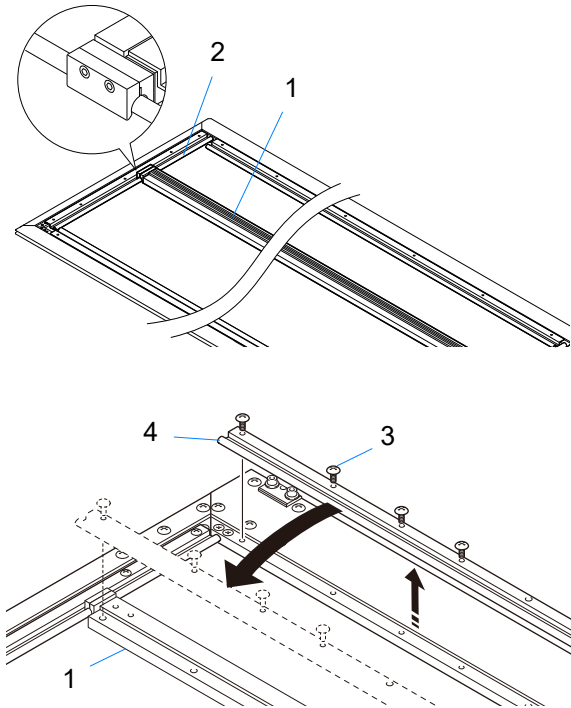

1 Install the middle sash 1 lengthwise across the border frame lengthwise sash 2 in the position that matches the size of the embroidery design.

2 Remove the screws 3 on the rear side and detach the border frame crosswise sash 4.

3 Install the border frame crosswise sash 4 to the middle sash 1 and fasten them with the screws 3 removed in step 2.



• The procedure after this differs depending on whether you use one-piece or two-piece stays.

#### When using one stay

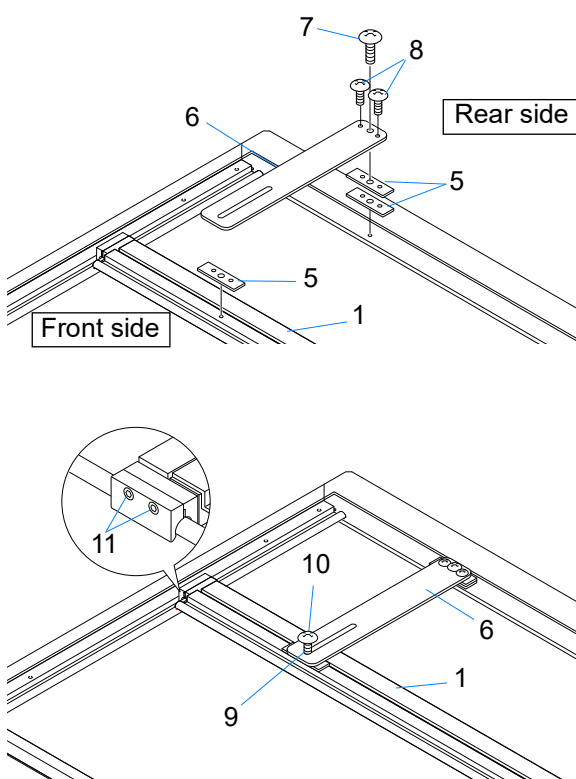

1 Place the specified number of spacers 5 (one for the front side and two for the rear side) on the face from which you removed the border frame crosswise sash 4 and the upper face of the middle sash 1.

2 Install the stay 6 over the spacers 5 on both sides and fasten the rear side of the stay 6 with the truss head screw 7 (JIS M4x12) and the truss head screws 8 (M3x5).

3 Align the middle sash 1 to the end 9 of the slotted hole on the stay 6 front side and fasten it with the truss head screw 10 (JIS M4x12).

4 Fasten the screws 11 on the both sides of the middle sash 1.

## ■ When using two stays in set

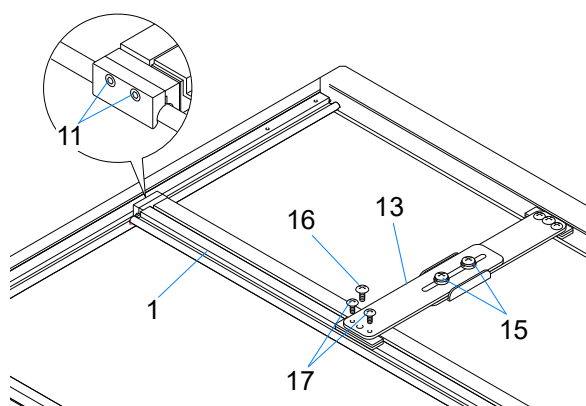
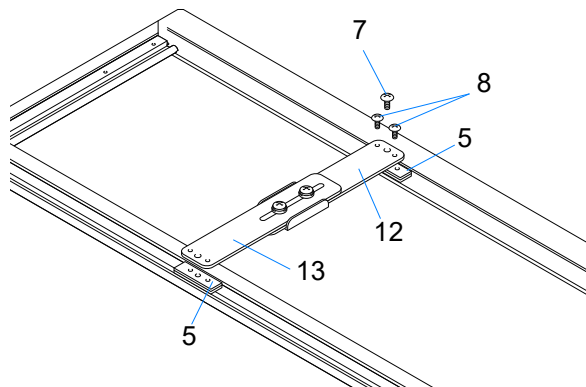
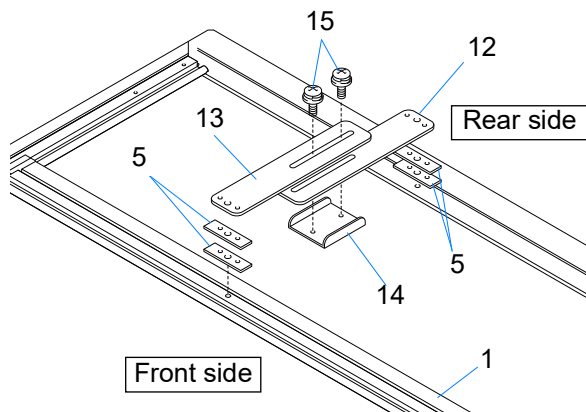

- 1 Place the specified number of spacers 5 (two for the front side and two for the rear side) on the face from which you removed the border frame crosswise sash 4 and the upper face of the middle sash 1.
- 2 Place the stay 13 (front-side) over the stay 12 (rear-side), couple them using the joint 14, and temporarily tighten the screws with washers 15 (M4x12).
- 3 Install the coupled stays 12 and 13 over the spacers 5 on both sides and fasten the stay 12 (rear side) with the truss head screw 7 (JIS M4x12) and the truss head screws 8 (JIS M3x5).
- 4 Slide lengthwise the stay 13 (front-side) to align it to the middle sash 1 and fasten it with the truss head screw 16 (JIS M4x12) and the truss head screws 17 (JIS M3x5).
- 5 Fasten the screws with washers 15 (M4x12) you temporarily tightened in step 2 and fasten the screws 11 on the both ends of the middle sash 1.

## 4-4. Quantity of stays and breakdown of accessories

The following tables show the quantity and types of stays that come with the machine.

### ■ Breakdown of stays for each spec.

Machine spec., model	Part name (stay type)	Part No.
Y axis length: 450 mm	STAY :MIDDLE SASH :A	0G031005A000
	STAY :MIDDLE SASH :B	0G031005B000
Y axis length: 450 mm (For TCMX)	STAY :MIDDLE SASH :B	0G031005B000
	STAY :MIDDLE SASH :C	0G031005C000
Y axis length: 550mm (Concomitant use with TCMX)	STAY :MIDDLE SASH :A	0G031005A000
	STAY :MIDDLE SASH :C	0G031005C000
Y axis length: 680 mm, 850 mm (Concomitant use with TCMX)	STAY :MIDDLE SASH :B	0G031005B000
	STAY :MIDDLE SASH :C	0G031005C000
	STAY :MIDDLE SASH :D	0G031005D000
Y axis length: 750 mm, 800 mm (Concomitant use with TCMX)	STAY :MIDDLE SASH :A	0G031005A000
	STAY :MIDDLE SASH :B	0G031005B000
	STAY :MIDDLE SASH :D	0G031005D000
Y axis length: 950 mm, 1000 mm (Concomitant use with TCMX)	STAY :MIDDLE SASH :A	0G031005A000
	STAY :MIDDLE SASH :B	0G031005B000
	STAY :MIDDLE SASH :C	0G031005C000
	STAY :MIDDLE SASH :D	0G031005D000
Y axis length: 1200 mm, 1300 mm (Concomitant use with TCMX)	STAY :MIDDLE SASH :A	0G031005A000
	STAY :MIDDLE SASH :B	0G031005B000
	STAY :MIDDLE SASH :C	0G031005C000
	STAY :MIDDLE SASH :E	0G031005E000
Y axis length: 1400 mm, 1500 mm (Concomitant use with TCMX)	STAY :MIDDLE SASH :A	0G031005A000
	STAY :MIDDLE SASH :B	0G031005B000
	STAY :MIDDLE SASH :C	0G031005C000
	STAY :MIDDLE SASH :D	0G031005D000
	STAY :MIDDLE SASH :F	0G031005F000

Machine spec., model	Part name (stay type)	Part No.
Y axis length: 1600mm	STAY :MIDDLE SASH :A	0G031005A000
	STAY :MIDDLE SASH :B	0G031005B000
	STAY :MIDDLE SASH :C	0G031005C000
	STAY :MIDDLE SASH :D (two pieces are used)	0G031005D000
	STAY :MIDDLE SASH :F	0G031005F000

### ■ Number of stay sets per one machine

Cross-type Z-spec. frame		Excluding cross-type Z-spec. frame	
The number of shafts for Y-axis drive system	Number of sets	The number of shafts for Y-axis drive system	Number of sets
3	3	2	3
4	3	3	5
5	5	4	7
6	7	5	9

### ■ Breakdown of accessories per set

#### Stay: one-piece

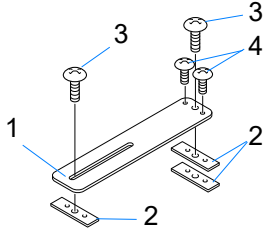
	Part name	Part No.	Q'ty	
	1	STAY :MIDDLE SASH	0G031005@000	-
	2	SPACER :MIDDLE SASH :2t	0G0310070000	3
	3	TRUSS HEAD SCREW :JIS M4 x 12	S130041202SD	2
	4	TRUSS HEAD SCREW :M3 x 5	S130030501MZ	2

#### Stay: two pieces in set

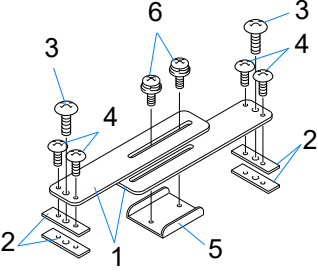
	Part name	Part No.	Q'ty	
	1	STAY :MIDDLE SASH	0G031005@000	-
	2	SPACER :MIDDLE SASH :2t	0G0310070000	4
	3	TRUSS HEAD SCREW :JIS M4 x 12	S130041202SD	2
	4	TRUSS HEAD SCREW :M3 x 5	S130030501MZ	4
	5	JOINT :MIDDLE SASH	0G0310060000	1
6	SCREW WITH WASHER :M4 x 12	S660041201MZ	2	



1st edition      August 2018

5th edition      March 2025

■ **Manufactured by : TISM Co.,Ltd.**

Address : NO.1800, Ushiyama-cho, Kasugai, Aichi -pref., 486-0901, Japan  
TEL : 81-568-33-1161    FAX : 81-568-33-1191

■ **Distributed by : Tajima Industries Ltd.**

Address : NO.1800, Ushiyama-cho, Kasugai, Aichi -pref., 486-0901, Japan  
TEL : 81-568-37-1130    FAX : 81-568-37-1230