



USER'S MANUAL

Operation

This manual describes the procedures for operating the machine, performing embroidery, and performing maintenance.

TMBR2-SC
TMBP2-SC
TMBP2-XC

Foreword

Thank you for purchasing the TAJIMA embroidery machine.

Please read this manual thoroughly, understand the contents, and then use the machine.

This manual may contain discrepancies in detailed specifications when compared with the actual product. If you have any question, please ask the distributor for information.

Purpose of This Document

This manual and other documents contain the following information. Refer to the necessary documents depending on the application and purpose. The user's manual and other documents are stored as PDF files on the supplied DVD.

■ USER'S MANUAL

For Safe Use

This manual contains instructions on using the machine safely. Make sure to read the manual before use.

Basics

This manual describes the basic knowledge and procedures that are common to all the models and required to use the machine.

If you are a novice to or unfamiliar with the machine, be sure to read this manual first.

Operation (this document)

This manual describes the procedures for operating the machine, performing embroidery, and performing maintenance.

Parameter Setting

This manual describes various parameters.

Frame Change

This manual describes how to change the frames.
This does not come with some models.

Various Documents

Electrical system diagrams and other technical documents.

■ Other manuals

Quick Guide

This sheet is the Quick reference regarding embroidery methods as well as frequently used functions and their operation procedures.



Keep the Quick Guide handy so that you can reference it quickly.

Optional Device

This manual describes how to set up, operate, and maintain various optional devices.

Safety Precautions and Symbols



Items that require your special attention on handling the machine are specified below.

Description	Meaning
 DANGER	Indicates that there is a lot of danger of death or serious injuries* ¹ .
 WARNING	Indicates that there is a likelihood of death or serious injuries* ¹ .
 CAUTION	Indicates a potentially hazardous situation which may result in minor or moderate injury* ² or physical damage.



*1: A condition caused by electric shock, injury, fracture of a bone etc. that leads to aftereffects, or an injury that necessitates hospitalization or visits to a hospital over a long period.

*2: An injury that does not necessitate hospitalization or visit to a hospital over a long period.

The symbols used throughout this document have the following meanings.

Symbol	Meaning
	Item to be prohibited
	Items that may cause electric shock if not observed
	Items to keep safety

Other Precautions

Description	Meaning
	Items that may affect sewing if not observed.
	Recommended and useful tips.



Disclaimer, etc.

- The external views and specifications of the machine and the contents of this manual are subject to change without notice due to improvement.
- The screen captures and figures contained in this manual may differ depending on the machine specifications, the number of heads or needles, and the presence of optional device.
- TAJIMA bears no responsibility regarding any damage arising from not observing the instructions in the manual or any fault or damage resulting from repair, disassembly, or modification not indicated in the manual.
- You may not copy, reproduce, or transcribe a part or whole of this manual without consent of TAJIMA.

About Functional Limit

To prevent unnecessary export and incorrect parameter settings, functional limit levels are used to restrict the use of particular functions.

The following functions are restricted at each functional limit level.

Functional limit level	Limit contents
	No limit <ul style="list-style-type: none">• All parameters are displayed• All functions are enabled• Parameter display is freely selectable
	<ul style="list-style-type: none">• Only certain parameters (pages P1 to P6) are displayed ^{*1}• Saving designs in the USB memory• Design date in the machine memory is protected from edits (Insertion of stitch, deletion of stitch, modification of stitch)• Detailed setting at needle bar (Satin stitch (area), Satin stitch (density), Satin stitch (expansion))
	<ul style="list-style-type: none">• All parameters except for “2. Functional limit level” on the P8 page are hidden• Saving designs in the USB memory• Design date in the machine memory is protected from edits (Insertion of stitch, deletion of stitch, modification of stitch)• Detailed setting at needle bar (Satin stitch (area), Satin stitch (density), Satin stitch (expansion))

*1: Press P6 twice to display “2. Functional limit level” on the P8 page.

- The functional limit level is set to  at shipment. Changing the functional limit level requires you to enter the password. For details, consult the distributor.

Chapter 1

Basic Operation of the Machine

1. Turning ON/OFF the Power	11
1-1. Turn ON the power	11
1-2. Turn OFF the power	12
2. Start and Stop of the Machine	13
2-1. Start the machine	13
2-2. Stop the machine	13
3. Screen Operations	14
3-1. Main screen	15
3-2. Design selection screen	17
3-3. Description of basic icons	18
4. Travel of Frame	20
4-1. How to move the frame	20
4-2. Changing the travel speed	20
4-3. Checking the frame position (coordinates)	21
5. Connecting an External Device	22
5-1. Connecting a USB memory	22
5-2. Connection of LAN cable	23
6. Others	24
6-1. Laser Crosshair Marker	24

Chapter 2

How to Embroider

1. Basic Flow of Embroidery	25
2. Embroidery Procedures	26
2-1. Saving or Storing designs into the machine memory	26
2-2. Selecting the embroidery design (data setting)	28
2-3. Setting of needle bar step	29
2-4. Confirmation of design	30
2-5. Setting the embroidery speed (Maximum R.P.M.)	30
2-6. Setting the design start position	31
2-7. Checking the embroidery position (execution of trace)	32
2-8. Starting embroidery	34
2-9. Completion of embroidery	35

3. Making Use of DCP (TMBR2-SC)	36
3-1. Setting items for presser foot	36
3-2. About Setting Operation	38
3-3. Settings on needle bar setting screen	39
3-4. Settings on manual operation screen	40
4. Responding to Thread Breakage	41
4-1. How to respond to a thread breakage indicator	41
4-2. Repair stitches	42

Chapter 3

Manual Operation

1. Moving Back or Moving Forward the Frame Along the Stitches	44
1-1. Frame back/frame forward operation screen	45
1-2. Frame Back/frame Forward by 1-stitch unit	46
1-3. Frame Back/Frame Forward by specifying the number of stitches	47
1-4. Frame Back/Frame Forward by specifying the number of color change	48
2. Thread Trimming	49
2-1. Operating the ATH	49
3. Needle Bar Related Operations	50
3-1. Color Change	50
3-2. Raising or lowering the needle bar	51
3-3. Stopping the needle bar at the lower dead point	52
3-4. Raising or lowering the presser foot (TMBR2-SC)	53
4. Various Frame Movement Operations	54
4-1. Moving the frame to the preset optional position	54
4-2. Moving the frame to the original position (manual offset)	55
4-3. Moving the frame to the start position	55
4-4. Moving the frame to the offset position	56
4-5. Moving the frame by entering a numeric value	57
4-6. Absolute origin search	58
4-7. Power Resume	59
5. Other Operation	60
5-1. ATH cleaning mode	60
5-2. Turning ON/OFF the LED lamp	61
5-3. Needle bar active/suspended	62

Chapter 4 Design Management

1. Inputting/Outputting Designs	63
1-1. From the machine memory to a USB memory	63
1-2. How to connect the machine to your PC	66
1-3. From PC to the machine memory	68
1-4. From PC to the machine memory (Barcode reader)	69
2. Deleting Designs	70
2-1. Deleting a design in the machine memory (one design at a time)	70
2-2. Deleting designs in the machine memory (two or more designs at once)	71
2-3. Deleting designs in the USB memory	73
3. Changing the Design Name and Storage Location	74
3-1. Changing a design name.	74
3-2. Changing the design storage location	75

Chapter 5 Editing Needle Bar Steps and Designs

1. Editing Needle Bar Steps	77
1-1. Setting needle bar step embroidery conditions	77
1-2. Repetition of needle bar steps	80
1-3. Insertion of needle bar step	81
1-4. Deletion of needle bar step	81
1-5. Replacing the needle bar numbers at once	82
2. Needle Bar Management Function	84
2-1. Setting the needle bar thread color	84
3. Copying, Dividing and Combining Designs	86
3-1. Copying a design	86
3-2. Division of design	87
3-3. Combine of designs	88
4. Design Conversion	92
4-1. Scale up/down of design	92
4-2. Rotation of a design	94
4-3. Reverse of design	96
5. Design Position Adjustment	97
5-1. Outline of function	97
5-2. How to adjust	98

6. Setting for Repeat	103
6-1. Repeating a design by specifying the number of repetitions	103
6-2. Repeating a design by automatically calculating the number of repetitions	105
6-3. Reversing or rotating a design alternately	107
7. Editing Stitches	108
7-1. Search by stitch No.	108
7-2. Search by function code	109
7-3. Modification of stitch	111
7-4. Insertion of stitch	112
7-5. Deletion of stitch	114
7-6. Removal of tiny stitches	115

Chapter 6

Various functions

1. Automatic Frame Travel (Automatic Offset)	117
1-1. Outline of function	117
1-2. Registration of the Offset Position	119
1-3. Erasing the offset position	121
1-4. Moving the frame by specifying an arbitrary stitch	123
1-5. Moving the frame at the color change position	124
2. Marking	125
2-1. Outline of function	125
2-2. Creating a marking design	126

Chapter 7

Maintenance

1. Precautions for Maintenance	129
2. Maintenance Item List	130
3. Cleaning	131
3-1. Inside of the cylinder bed	131
3-2. Head and its surroundings	132
3-3. X-axis drive system, Y-axis drive system	132
4. Lubrication	133
4-1. Rotary hook	133
4-2. Inside of head	134

5. Greasing	135
5-1. Cylinder bed gear	135
5-2. Inside of head	136
6. Inspection and Repair	138
6-1. Inspection	138
6-2. Repair	138
7. Checking and Adjustment	139
7-1. Checking the needle bar lower dead point	139
7-2. Adjusting the stroke amount of the thread take-up spring	141

Chapter 8

Troubleshooting

1. Message Screen	144
2. When the Machine Does not Sew Well	149
2-1. Frequent thread breakages	149
2-2. Needle breaks	149
2-3. Embroidery results not good	150
3. Power Resume after Power Failure	151
4. Obtaining Log Data	152

Chapter 9

Appendix

1. Improving the Sewing Finish Quality (FS Mode)	153
1-1. Outline of function	153
1-2. Sewing comparison	154
1-3. Making use of optional parts	155
2. Upgrading the Software Version	156
3. Specifications	160
3-1. Electrical specifications	160
3-2. Ambient noise level	160
3-3. Machine weight	160
4. Electrical Block Diagram	161
5. Terminology	162

Chapter 1

Basic Operation of the Machine

1. Turning ON/OFF the Power

The power switch (PSW) is located on the right side of the machine.

TMBR2-SC, TMBP2-SC

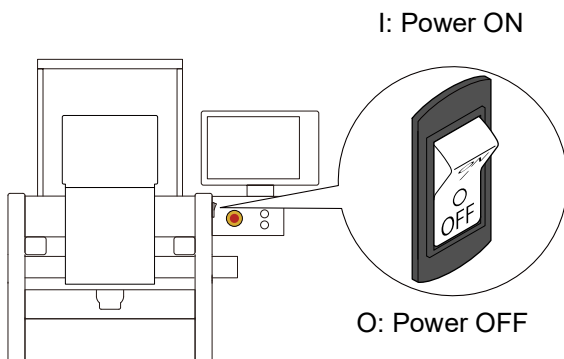

TMBP2-XC



1-1. Turn ON the power

CAUTION

- ⓘ To turn ON the power again, wait for 30 seconds or more. Otherwise the system may fail to start up normally.
- ⊘ Do not turn ON the power with a USB memory connected to the operation panel (OP). Otherwise the system may fail to start up normally.

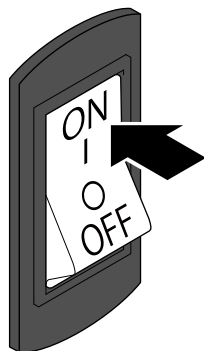

- 1 Turn ON the power.
The system starts up.



1. Turning ON/OFF the Power

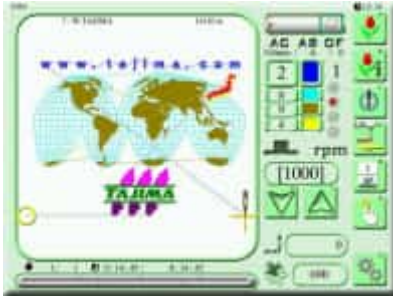

Once the system starts up, the main screen appears.

1-2. Turn OFF the power

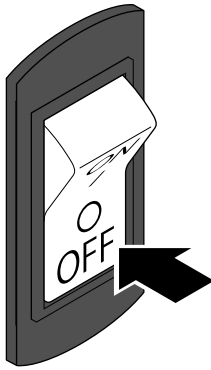

1 Turn OFF the power.



- Unless in an emergency, do not turn OFF the power by pressing the emergency stop switch.

2. Start and Stop of the Machine

To start and stop the machine, use the start/stop switch located on the front face of the machine.

2-1. Start the machine

⚠ CAUTION

- Before starting the machine, pay enough attention to the surrounding safety. You may be injured by a moving needle bar or frame.

[To start the machine immediately]

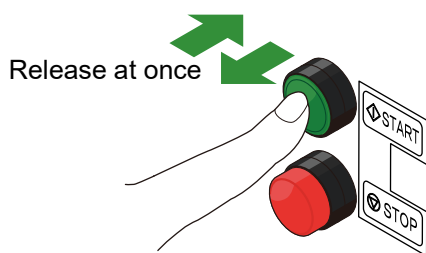

Press the start switch and release it immediately. The needle bar moves up and down slowly (in an inching manner) and then the machine starts operation.



- You can configure the number of inching times (during startup) with a parameter. For details, refer to the separate "Parameter Settings" manual.

[To start the machine gradually]

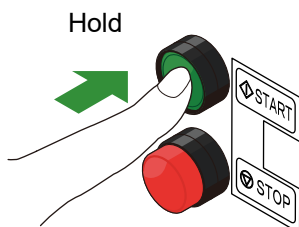

Press the start switch and hold it in that position. While you are holding it, the needle bar moves up and down slowly (in an inching manner).



- When you release the start switch, the machine starts normal embroidery operation.

2-2. Stop the machine

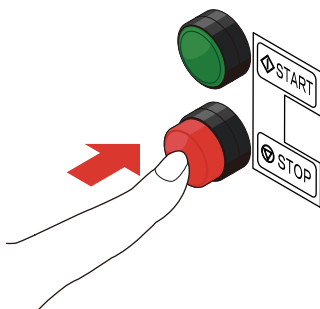

Press the stop switch. The machine stops operation.



- You can use the start/stop switch, not only to start and stop the machine, but also to move the frame along the stitches for repair stitching at thread breakage (Frame Back/Frame Forward). For details, refer to "Chapter 3 1. Moving Back or Moving Forward the Frame Along the Stitches".

3. Screen Operations

Use the operation panel (OP) to perform operations for embroidery and configure various settings. The touch panel allows you to switch the display screen and configure various settings by lightly touching the icons displayed on the screen.

⚠ CAUTION

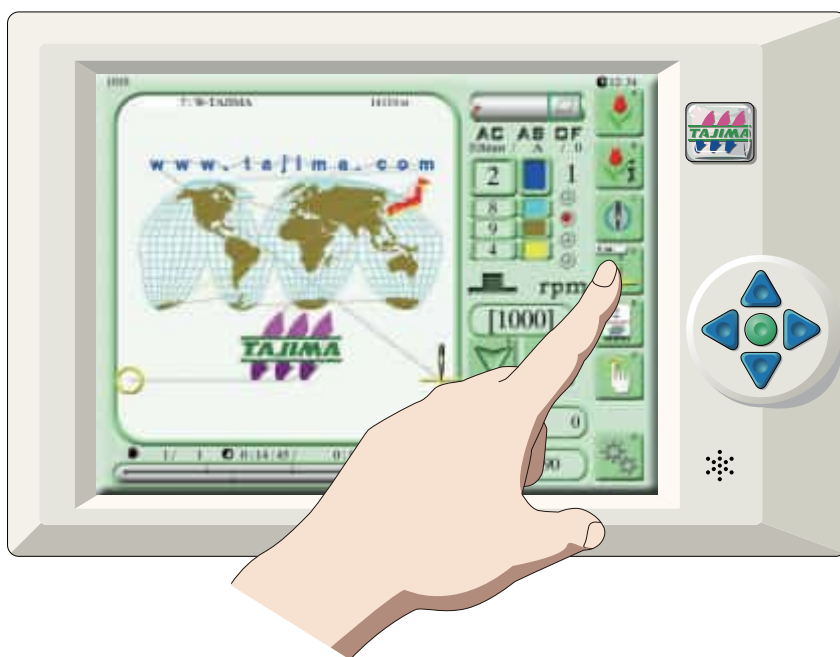

- ! Touch them with your finger.
- ⊘ Do not forcibly press the touch panel or apply something sharp to it because doing so may break the panel.



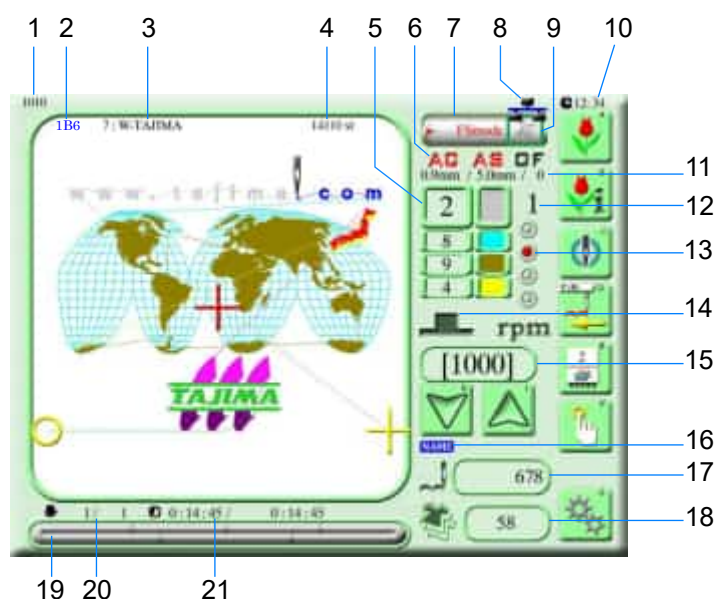

3-1. Main screen

The main screen appears once you turn ON the power and the system successfully starts up. You can begin to configure various settings and operate the machine from the main screen.

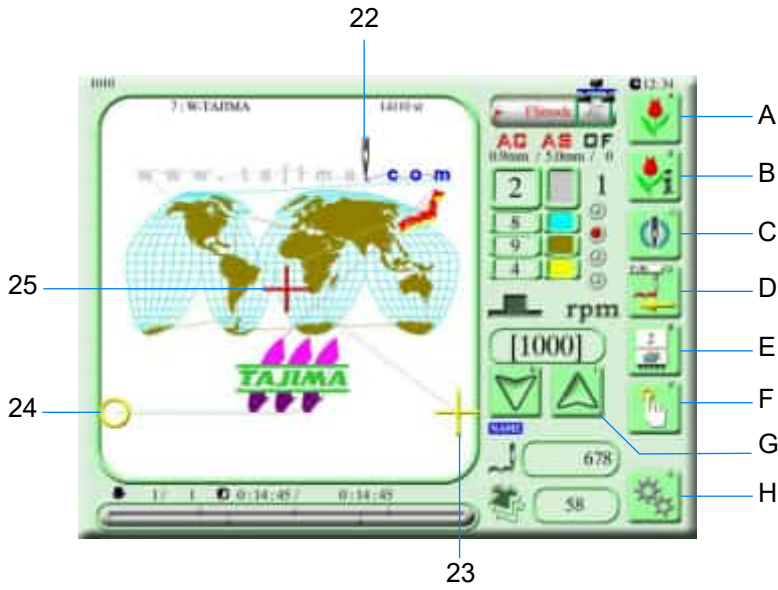

No.	Description	No.	Description
1	Screen number	12	Current needle bar step No.
2	Stop factor (displayed during stop of the machine)	13	Setting status of offsetting at automatic color change (displayed in red if enabled)
3	Design name		
4	Total number of stitches of design	14	Current main shaft angle  Fixed position (Press and hold to release the main shaft brake)  Main shaft brake released (Press and hold to excite the main shaft brake)  Outside of range of fixed position
5	Needle bar No. of the current step		
6	AC (Auto Color Change), AS (Auto Start), and OF (Automatic Offset) setting status (displayed in red if the setting is enabled)		
7	FS mode setting status ("FS mode" is displayed if enabled)	15	Maximum speed (Maximum RPM)
		16	Continuous name ("NAME" is displayed if enabled)
8	Network connection status (The icon is displayed if enabled)	17	Current number of stitches
		18	Cumulative embroidery count (even if the power is turned OFF/ON, counting will continue.)
9	Frame type being set	19	Embroidery progress (indicated by red scale marks)
10	Current Time	20	Number of repetitions (current count/total count)
11	Presser foot lower dead point/ Presser foot stroke/ Presser foot timing	21	Remaining time for embroidery (Remaining time to complete embroidery/total time of repetition)



No.	Description	No.	Description
22	Current embroidery position	D	Navigate to current FB (Frame Back)/FF (Frame Forward) setting condition and FB/FF screens
23	Embroidery start point		
24	Embroidery end point		
25	Frame start position (9P) Displayed in place of the embroidery starting point when enabled	E	Navigate to the manual color change screen (the displayed number is the current needle bar No.)
A	Navigate to the design selection screen	F	Navigate to the manual operation screen
B	Navigate to the detailed information screen of design	G	Adjustment of RPM
C	Needle bar operation / suspension	H	Navigate to the parameter setting screen
	 : Active head  : Suspended head		



• For details on the frame start position (9P), see the separate "Parameter Setting" manual.

3-2. Design selection screen

This screen lets you save, select, or edit your design.

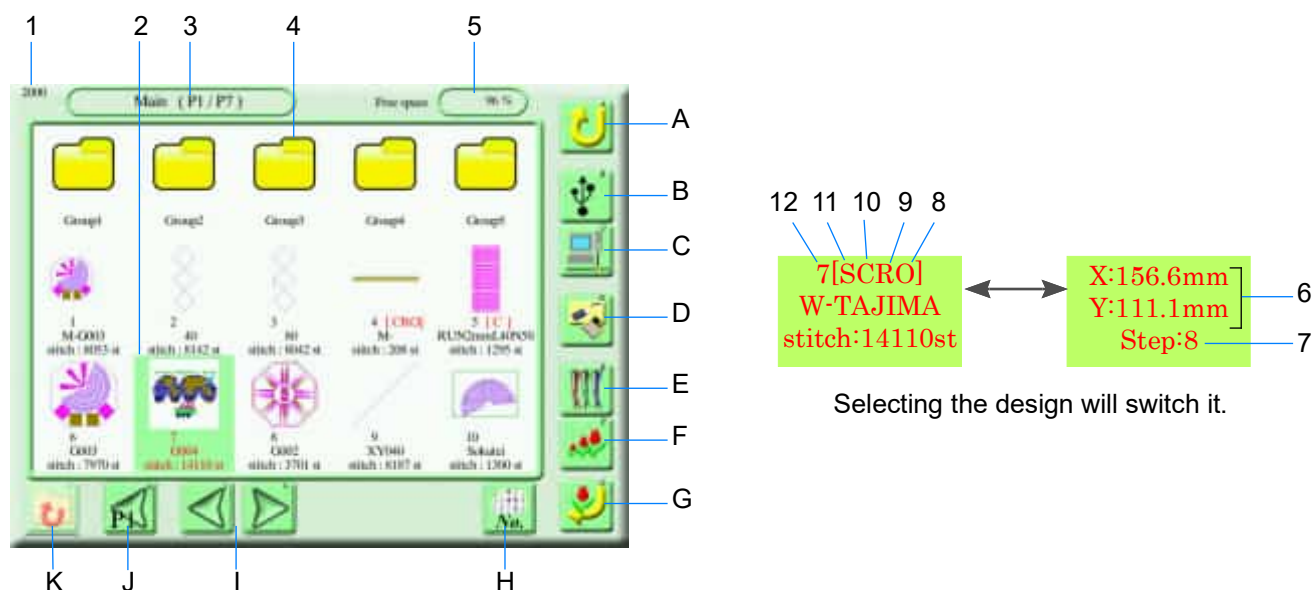

No.	Description	No.	Description
1	Screen number	B	Navigate to the USB memory screen
2	Design stored in the machine memory	C	PC connected
3	Screen page	D	Navigate to the design edit screen
4	Design storage folder (You cannot change the folder names "Group1" to "Group5")	E	Navigate to the needle bar selection screen
5	Machine memory capacity (40,000,000 stitches) (Free space percentage (%) is displayed. The remaining number of stitches is displayed instead if the free space is 20% or lower.)	F	Navigate to the design enlargement/reduction and repeat screens
		G	Save Changes (navigate to the data set screen)
6	Design size	H	Rearrangement of designs (Designs are reordered every time you touch the icon.) <ul style="list-style-type: none"> No.: In the ascending order of machine memory numbers Name: Alphabetical design name order Time: Updating order
7	Number of needle bar steps		
8	With setting of automatic offset		
9	With setting for repeat		
10	With setting for scaling up/down of design	I	Navigate to the previous or next page
11	Indicates that the embroidery condition for the needle bar step has been changed	J	Back (return to the first page)
12	Machine memory No. (When you store a design in the machine memory, the next available machine memory No. is assigned)	K	Back (return to the "Main" folder screen if the "Group" folder is selected)
A	Back (return to the previous screen)		



- The icon C is not displayed if a PC is not connected.
- When there is no design in the machine memory, the icons D, E, and F are not displayed.

3-3. Description of basic icons

There are common icons you can use to switch the display screen, save settings, or enter alphanumeric characters.

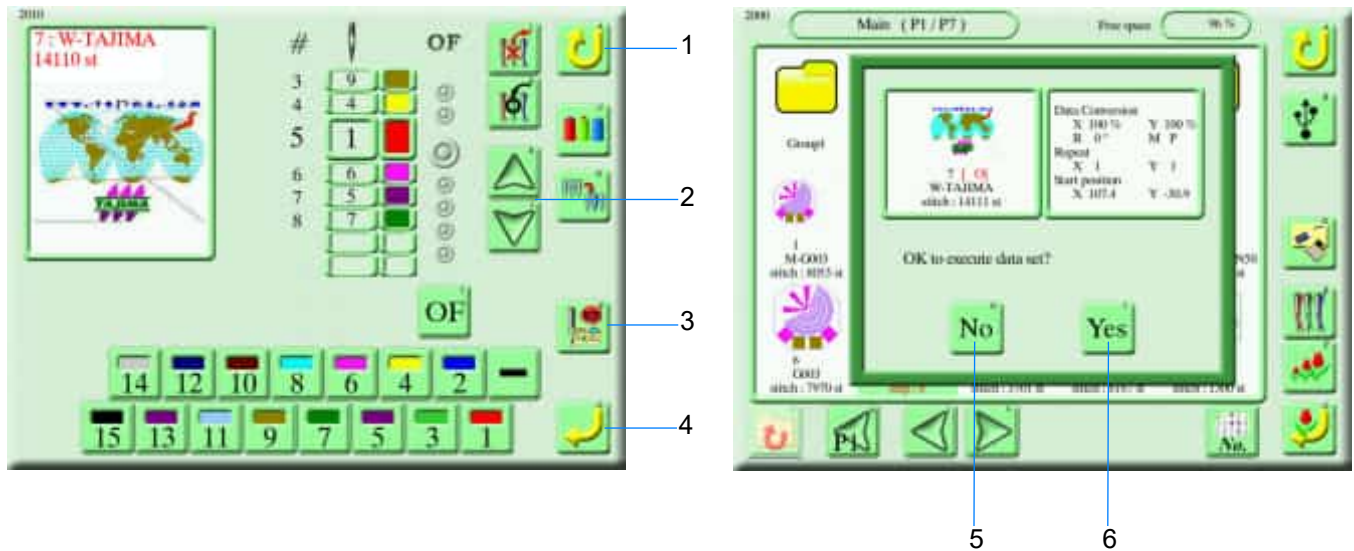

Common icons

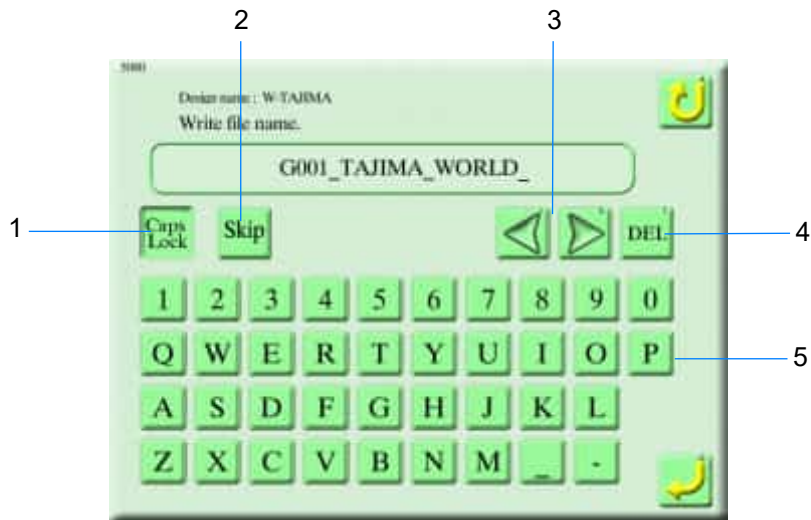

No.	Description
1	The screen will return to the previous screen by one.
2	Increase/decrease the value or scroll up/down the screen.
3	Show advanced settings.
4	Put the setting into effect.
5	Cancel the operation and disable the setting.
6	Save or enable the setting.

■ Entering alphanumeric characters



No.	Description
1	Toggle between uppercase and lowercase.
2	<p> : If there is a design with the same name in USB memory, it will be overwritten and saved.</p> <p> : If there is a design with the same name in USB memory, the new design will be saved under the file name appended with (1) at the end.</p>
3	Move the cursor.
4	Delete the character at the cursor position.
5	Enter a character by pressing the corresponding icon.

4. Travel of Frame

To manually move the frame, use the frame travel keys on the operation panel (OP).
 To change the frame travel speed, use the speed switching key.

4-1. How to move the frame

While you are holding down one of the frame travel keys, the frame keeps moving in that direction.

⚠ CAUTION

⊘ Do not put your hand on the table or bring your hand close to the frame because doing so may cause your finger or hand to be injured when the frame moves.

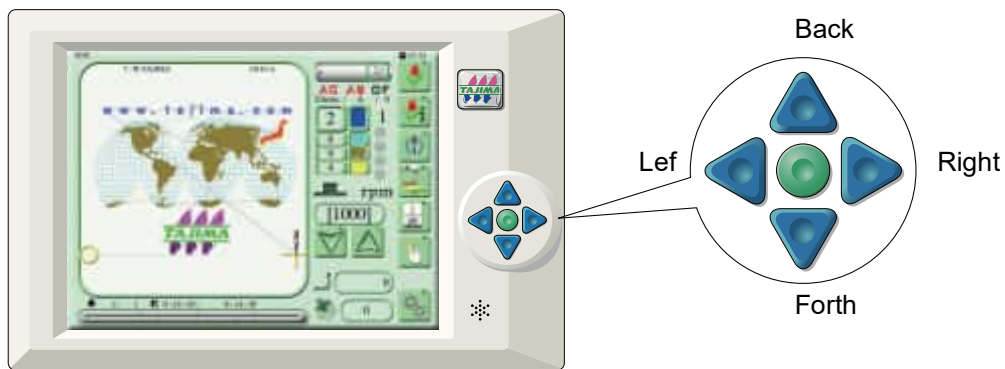

- A message screen appears when the frame reaches the limit of the embroidery space. Press the icon (return) to move the frame into the embroidery space.
- If you have moved the frame by hand with the power OFF, turn ON the power and execute absolute origin search. For more information on absolute origin search, refer to the separate "Chapter 3 4-6. Absolute origin search".

4-2. Changing the travel speed

You can toggle between the low and middle frame travel speeds by pressing the speed switching key.
 Also, you can move the frame at high speed by pressing one of the frame travel keys while holding down the speed switching key.

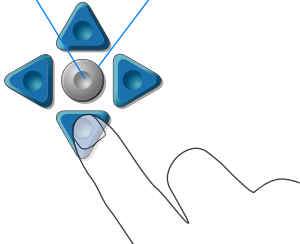
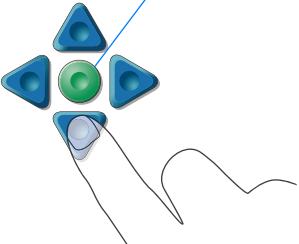
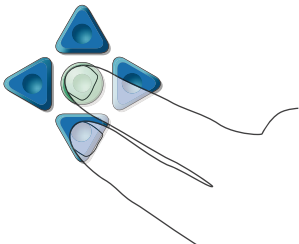
Low speed	Middle speed	High speed
<p>Press the speed switching key to turn off its back light, then press one of the frame travel keys.</p> <p>Speed switching key Unlit</p> 	<p>Press the speed switching key to turn on its back light, then press one of the frame travel keys.</p> <p>Speed switching key Lit</p> 	<p>Press one of the frame travel keys while holding down the speed switching key.</p> 

4-3. Checking the frame position (coordinates)

You can check the current frame position (coordinates) on the manual operation screen.



- To display the manual operation screen, press  on the main screen.

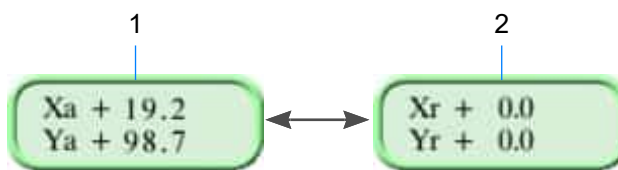
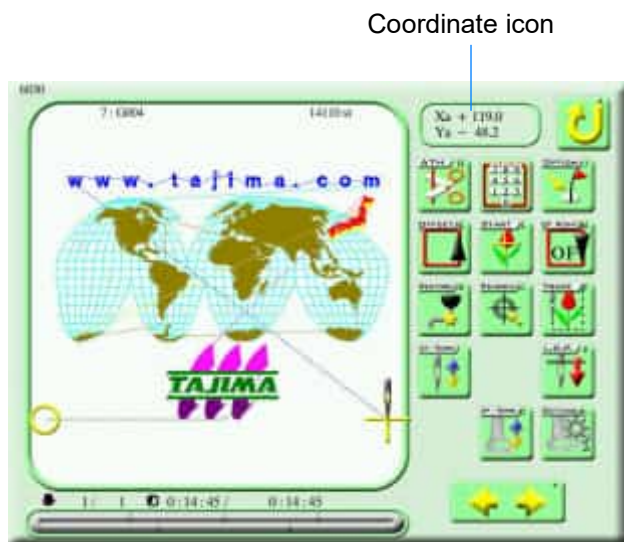

Pressing the coordinate icon will change the indication.

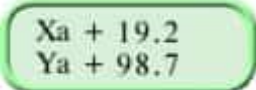
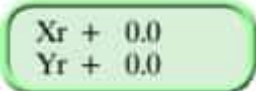
No.	Coordinate icon	Description
1		The coordinates based on the absolute origin of the frame appear.
2		The coordinates based on the start position of the design whose data is set appear.



- If the coordinates are not correctly displayed, the absolute origin may not be correctly set. Execute absolute origin search. For more information on absolute origin search, refer to "Chapter 3 4-6. Absolute origin search".

5. Connecting an External Device

5-1. Connecting a USB memory

The machine has two USB ports which are located at the back side of the operation panel (OP) and the right side of the operation panel (OP) base.

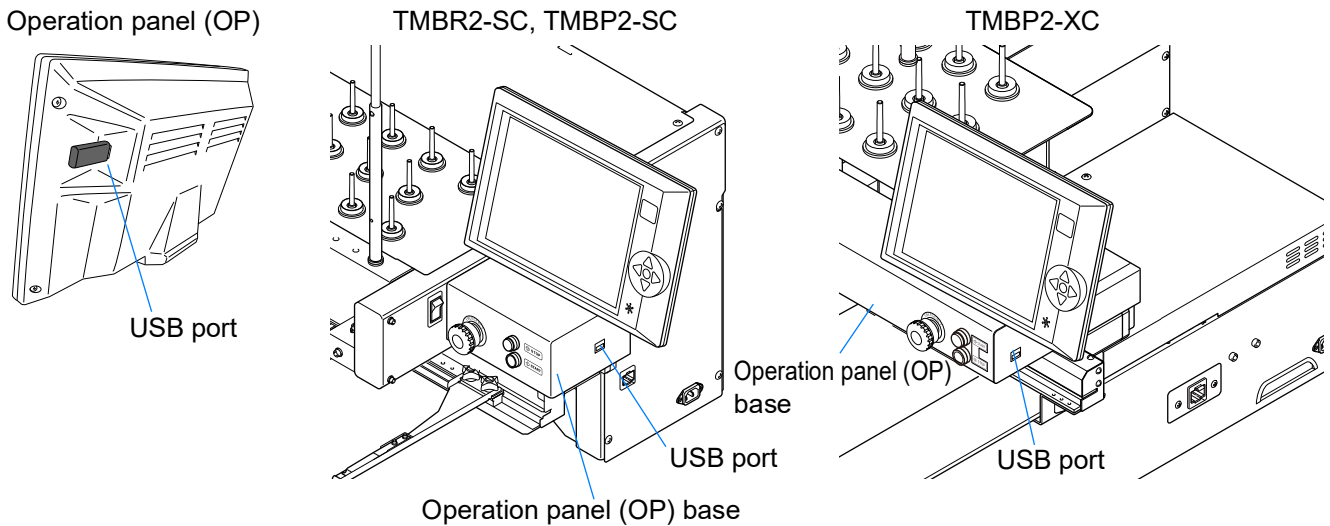

USB port has two usages as follows:

- Insert to a USB memory to USB port to input/output designs or upgrade the software version.
- Connect a bar code reader to to USB port to input designs.

⚠ CAUTION

- ⊘ Do not turn ON the machine power with a USB memory inserted into the operation panel (OP). Otherwise the system may fail to start up normally.
- ⊘ Do not insert a USB memory if it contains dirt or dust inside the connector.
- ⊘ Do not insert or remove a USB memory while the machine is running.
- ⊘ Do not forcibly insert a USB memory.
- ⓘ Insert a USB memory slowly.
- ⓘ Insert a USB memory straight into the USB port. Diagonally inserting a USB memory may cause the connector to interfere with and possibly destroy the internal circuit board.
- ⓘ Do not attempt to use a USB memory until at least five seconds elapse after you insert it.



- The machine does not work with USB memories of certain types and capacities.
- Use a recommended USB memory (i.e., a USB 2.0-compliant USB memory formatted in the FAT/FAT32 format).

5-2. Connection of LAN cable

Connect a LAN cable to the LAN port on the right side of the machine. Use the LAN cable to connect the machine to your PC via LAN.

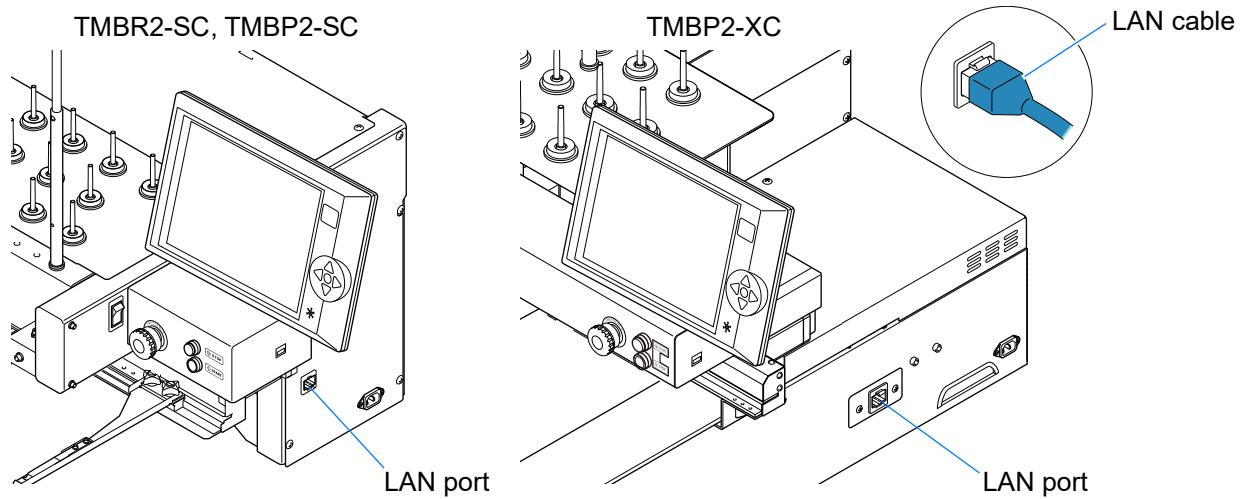

- To connect the machine via a router to your PC, use a straight cable available on the market.
- To directly connect the machine to your PC, use a cross cable available on the market.
- For more information on connecting the machine to your PC, refer to "Chapter 4 1-2. How to connect the machine to your PC".

Chapter 2

How to Embroider

1. Basic Flow of Embroidery

For details, refer to the corresponding guides and chapters.

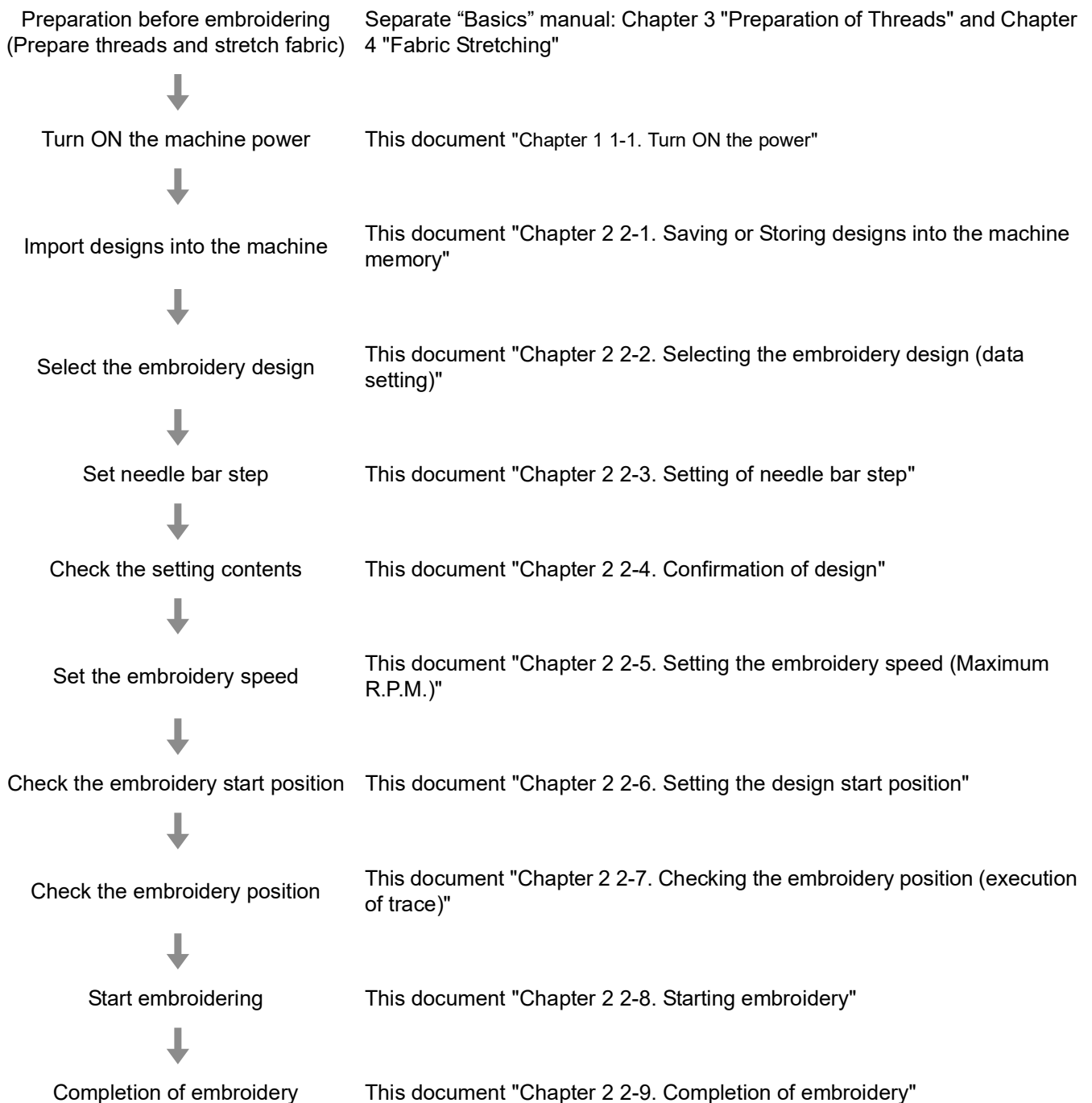

2. Embroidery Procedures

This section describes the procedures for importing the desired designs into the machine memory and starting and completing embroidery.

2-1. Saving or Storing designs into the machine memory

Save the embroidery design in the machine memory by one of the following methods.

- A USB memory
- Your PC
- A bar code reader

The following example shows how to select two designs from a USB memory and store them in the “Main” folder in the machine memory.



- The “Main” folder can store up to 200 designs and the folders from “Group1” to “Group5” can each store up to 90 designs(thus up to 650 designs in all). The maximum number of designs you can store may, however, be smaller than mentioned above depending on the free space of the machine memory.
- A design that has been embroidered contains the color change sequence and start position (condition data). When you store a design, its condition data will also be stored in the machine memory.
- The machine memory can store designs from your PC and bar code reader as well. For details, refer to "Chapter 4 1. Inputting/Outputting Designs".

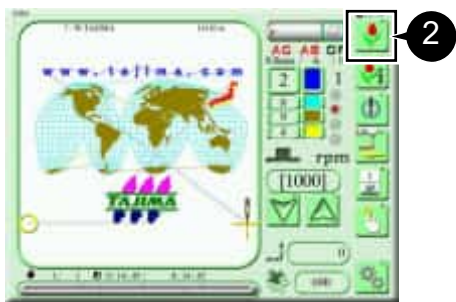

1 Insert a USB memory containing designs into the USB port on the operation panel (OP).

2 Press  on the main screen.

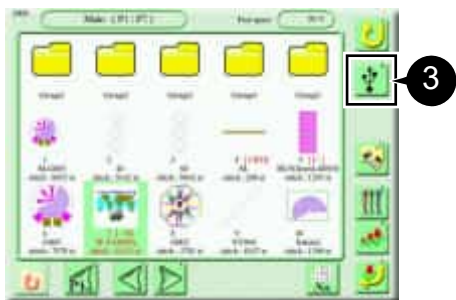

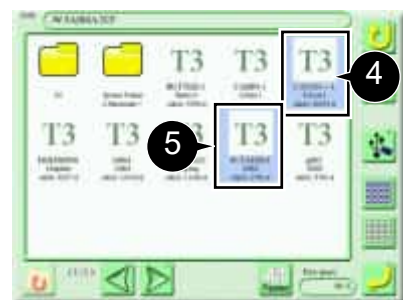

3 Press .



4 Select the first desired design.



-  Select all designs
-  Deselect all designs

5 Select the second desired design.

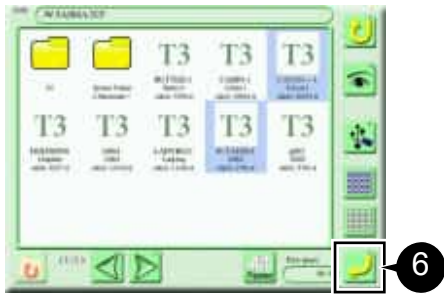

6 Press .



- If the maximum number of designs you can store is exceeded or the machine memory is short of free space, code No.2BA appears.
- When releasing the selection, press the design again.

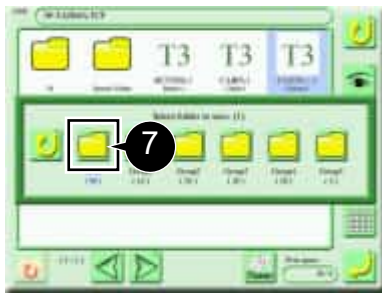

7 Press  "Main".

The selected designs are stored into the machine memory.

■ About the display of a design

In the USB memory, a design is displayed as follows.

T ← Saving format of design
G0003 ← File name
MADELENE ← Design name
stitch:30034st ← Number of stitches of design

Saving format of design

- T: TAJIMA format (DST)
- T2: TAJIMA binary format (TBF)
- T3: TAJIMA integrated file (TCF)

Depending on saving format of the design, the design except above one will be displayed.

1
2
3
4
5
6
7
8
9

2-2. Selecting the embroidery design (data setting)

Select the embroidery design so that the machine can start embroidery.

⚠ CAUTION

⊘ Do not put your hands on the table when you operate the machine because doing so may cause your finger or hand to be injured when the frame moves.

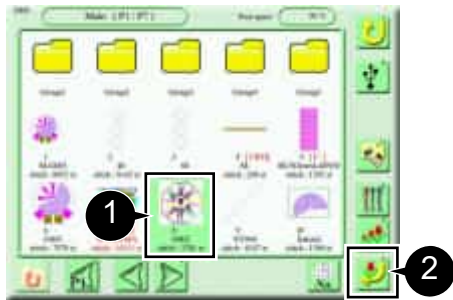

1 Select the embroidery design on the design selection screen.

2 Press .

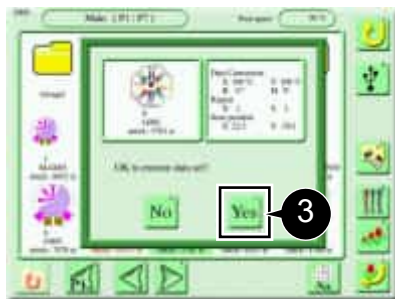

3 Press .

The design data is set.

[If the design contains the start and offset positions]

If the design contains the “start position” (i.e., the previous embroidery start position of the selected design) and “offset position”, the frame travel message screen appears after the data is set.

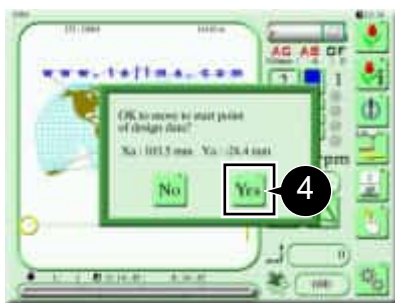

4 Press .

The frame moves to the start position or the offset position. If you select “No”, the frame doesn’t move.



- For more information on Automatic Offset settings, refer to "Chapter 6 1. Automatic Frame Travel (Automatic Offset)".

[If the design contains a message]

If the design contains a message created with DG by Pulse (optional design creation software), the message will appear after you set the data and upon completion of embroidery. For more information, refer to the user’s manual for DG by Pulse.

Example: After you set the data

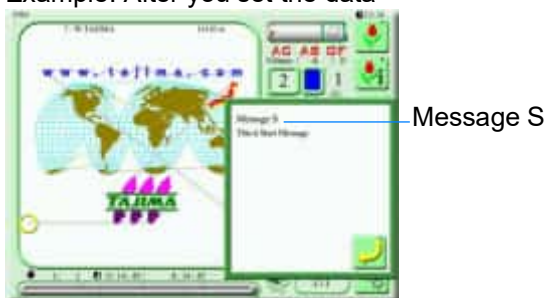

- Writing a message into the design data (****.TCF) requires DG15 by Pulse or later.

2-3. Setting of needle bar step

Set a needle bar to use (sewing order) for each needle bar step of the selected design.

The machine performs embroidery while automatically changing the color based on those settings.

The following example shows how to assign the needle bar No. 4 to the needle bar step 1 and the needle bar No. 6 to the needle bar step 2.



- If the “Auto Color Change” parameter is set to “No”, the machine will not automatically change the color. For details, refer to the separate “Parameter Settings” manual.
- This procedure is not required when the color change sequence is included as the condition data in the design.

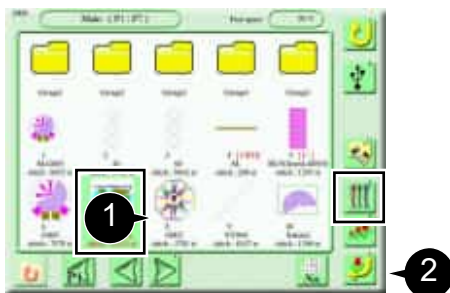

1 Select the desired design on the design selection screen.

2 Press .

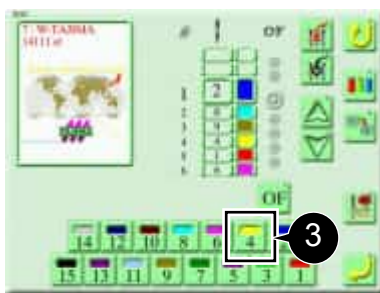

3 Press .

Needle bar No. 4 is assigned to the needle bar step 1 and the screen proceeds to the next needle bar step.



- To select an arbitrary needle bar step,

press .

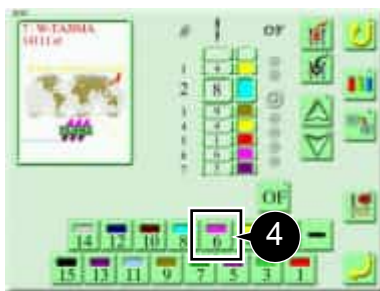

4 Press .

Needle bar No. 6 is assigned to the needle bar step 2 and the screen proceeds to the next needle bar step.

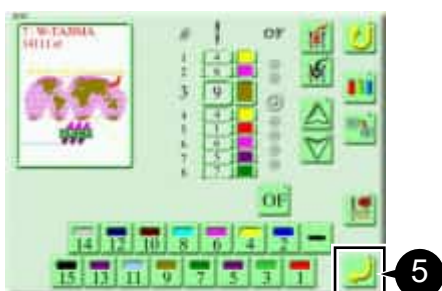

5 Press .

Now you are done configuring the needle bar steps.

2-4. Confirmation of design

You can check the size and orientation of the design whose data is set and other settings.

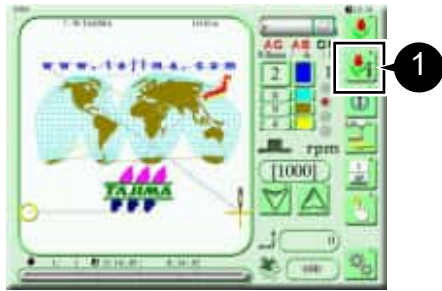

1 Press .

2 To check the settings, use the following confirmation screen.

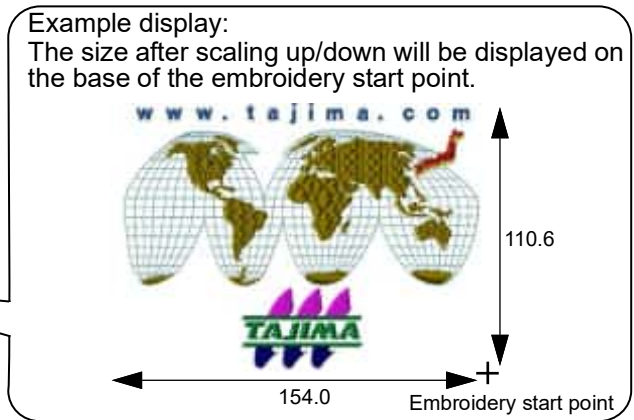
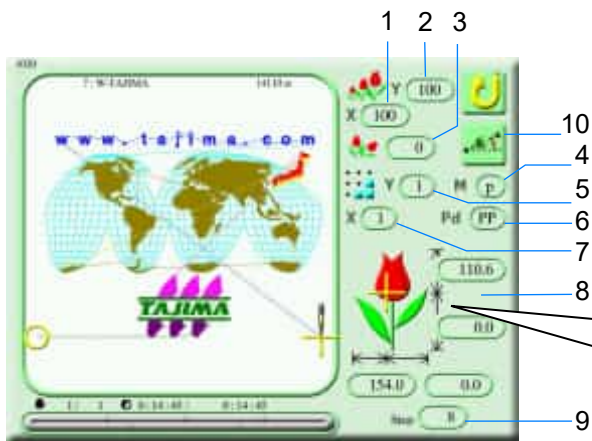

No.	Description	No.	Description
1	Scale ratio of design (Horizontal)	6	Design repeat pattern
2	Scale ratio of design (Vertical)	7	Number of repeats of design (Horizontal)
3	Rotating angle of design	8	Size of design (mm)
4	Reversion of design (p = do not reverse, q = reverse)	9	Number of needle bar steps of design
5	Number of repeats of design (Vertical)	10	Design position adjustment



• For more information on the settings, refer to "Chapter 6 1. Automatic Frame Travel (Automatic Offset)".

2-5. Setting the embroidery speed (Maximum R.P.M.)

You can set the maximum embroidery speed (Maximum R.P.M.). During operation, the embroidery speed changes according to the stitch length of the design without exceeding the configured maximum speed.

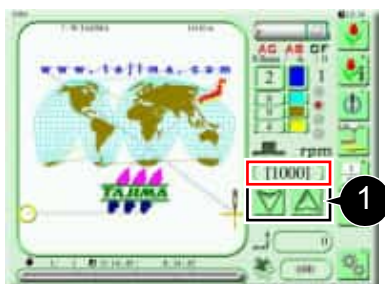

1 Press  to set the maximum speed. The new setting appears in the red box.



- Hold down  to change the value continuously.
- You can configure the setting in the middle of embroidery.

2-6. Setting the design start position

Sets the starting position for embroidery.

■ Position where the start switch is pressed

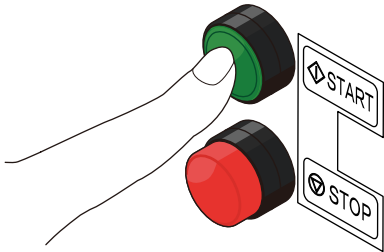

When the design start position is not set, the position of the frame where the start switch is pressed is the design start position.

■ If the design data has a design start position

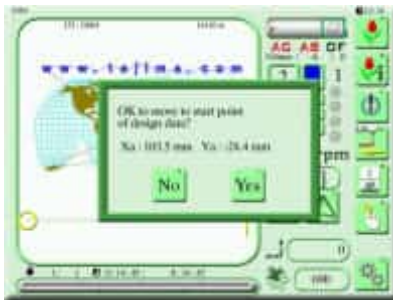

When data is set, the frame moves to the design start position set in the design data.



- When the frame is moved after data set, the position of the frame where the start switch is pressed changes to the design start position.

■ Trace start position



When no design start position is set, the position where the tracing starts is the design start position.



- For design to be embroidered for the first time, Set the design start position while adjusting the size and position with the trace.
- If the design data has a design start position, that position takes precedence.

2-7. Checking the embroidery position (execution of trace)

Before starting embroidery, you can move the frame along the contour of the design (as referred to as “tracing”) to check if the embroidery position (start position) is correct and check if the design will fall within the embroidery space.

■ Outline of trace

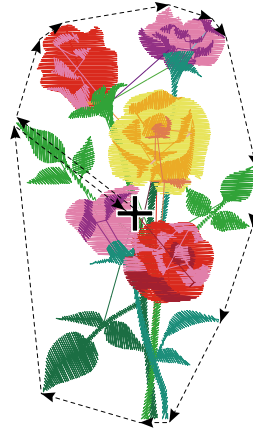
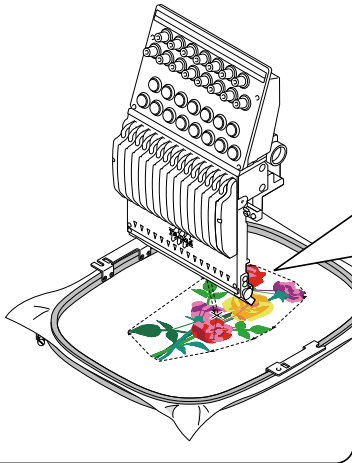

Tracing starts at the start position and proceeds along the contour of the design.

⊕ : Start position

[If Automatic Offset setting is enabled for the frame]

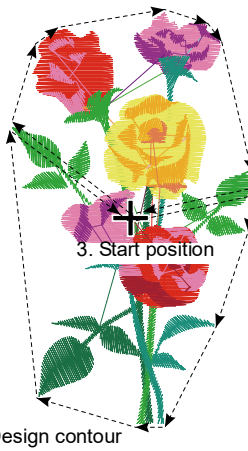

The machine will trace the following in this order.

1. Offset position
2. Offset middle position
3. Start position
4. Design contour
3. Start position
2. Offset middle position
1. Offset position

[If the repetition setting is enabled for the design]

The machine will trace whole designs after tracing the first design.

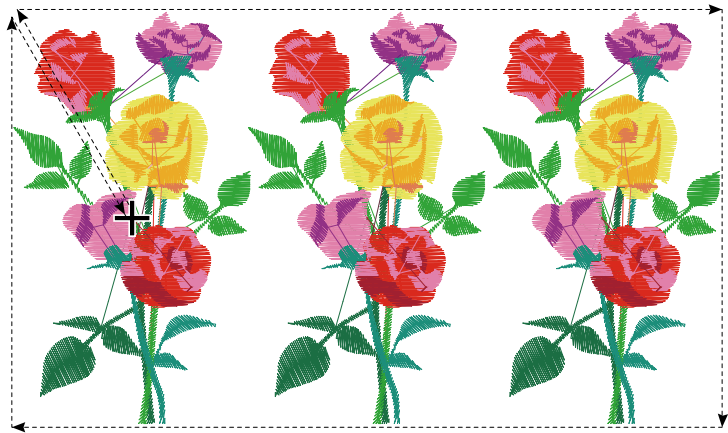

- For more information on Automatic Offset settings, refer to "Chapter 6 1. Automatic Frame Travel (Automatic Offset)".
- For more information on repetition settings, refer to "Chapter 5 6-1. Repeating a design by specifying the number of repetitions".
- For the setting of the presser foot up at tracing, refer to "Parameter Setting" manual.
- If the start position is not correct, the frame reverses and stops during tracing, and error appears.

■ Execution of trace

⚠ CAUTION

⊘ Do not put your hands on the table when you operate the machine because doing so may cause your finger or hand to be injured when the frame moves.

1 Using the frame travel key, move the frame to the start position.



• For more information on moving the frame, refer to "Chapter 1 4-1. How to move the frame".

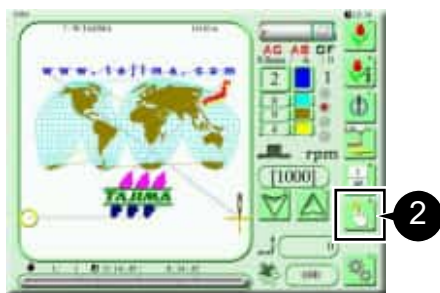

2 Press  on the main screen.

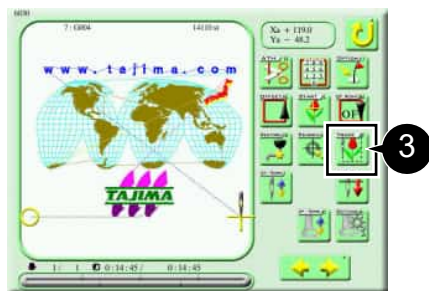

3 Press .



4 Execute tracing.



: High speed tracing by raising the presser foot height



: Low speed tracing by raising the presser foot height



• The position where tracing was executed is stored as the start position.
 • To suspend tracing, stop the machine. To resume tracing, follow instructions on the screen.

 2 : Current needle bar No. "+" is displayed for Laser crosshair marker.



When "Presser foot up at tracing" is set to "No" in the parameter, the icon display will be added.



: High speed tracing with the same presser foot height



: Low speed tracing with the same presser foot height

2-8. Starting embroidery

⚠ CAUTION

! Before starting embroidery, pay enough attention to the surrounding safety. You may be injured by a moving needle bar or frame.

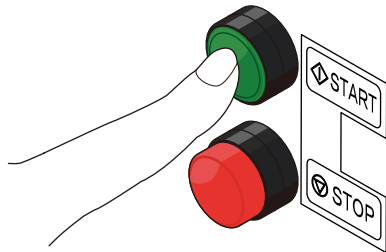

1 Press the start switch.

The needle bar moves up and down slowly (in an inching manner) and then embroidery starts.



- For more information on operating the start/stop switch, refer to "Chapter 1 2-1. Start the machine".

■ Checking the progress of embroidery

The progress of embroidery is indicated by red scale marks in the lower part of the main screen.

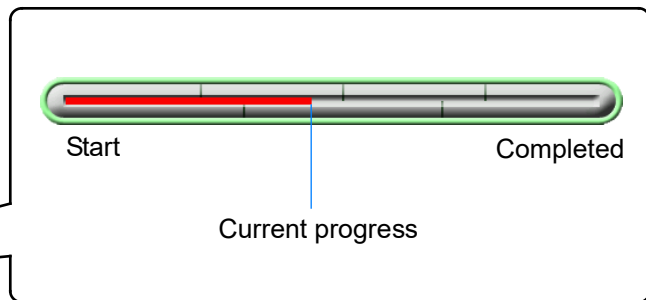
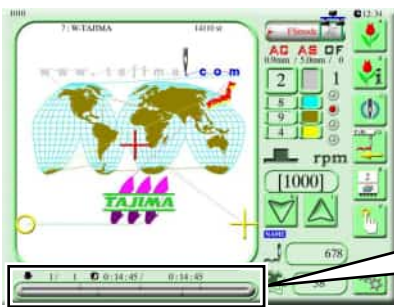

■ How to resume embroidery after moving the frame

After you manually move the frame during embroidery, you can resume embroidery by one of the following methods.

- Return the frame to the original position using manual offset operations and then resume embroidery using the start switch.
- Resume embroidery by pressing the start switch. (This method is only available if the "Return the frame after manual frame travel" parameter is set to "Yes".)



- For more information on manual offset, refer to "Chapter 3 4-2. Moving the frame to the original position (manual offset)".
- If the "Return the Frame after manual frame travel" parameter is set to "No", the frame does not return to the original position and embroidery resumes from the position the frame moved to. The parameter is set to "No" by factory default. For details, refer to the separate "Parameter Settings" manual.

2-9. Completion of embroidery

Upon completion of embroidery, the frame moves to the start position and the machine stops operation.

CAUTION

-  Do not put your hands on the table when embroidery is completed because doing so may cause your finger or hand to be injured when the frame moves.



- If the "Auto origin return" parameter is set to "Yes", the frame moves to the design start position upon completion of embroidery. If it is set to "No", the frame stops at the same position as when embroidery is completed. For details, refer to the separate "Parameter Settings" manual.

The frame moves to the start position

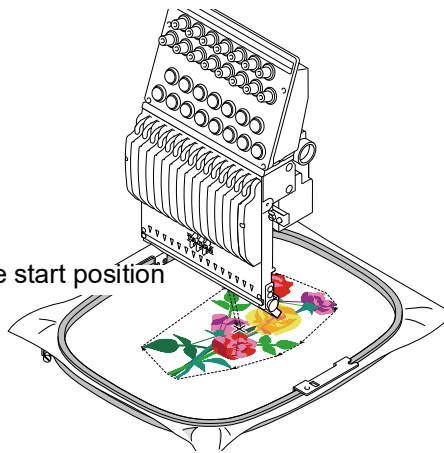

[If Automatic Offset setting is enabled for the frame]

Upon completion of embroidery, the frame moves to the offset position and the machine stops operation.



- For more information on Automatic Offset settings, refer to "Chapter 6 1. Automatic Frame Travel (Automatic Offset)".

The frame moves to the offset position

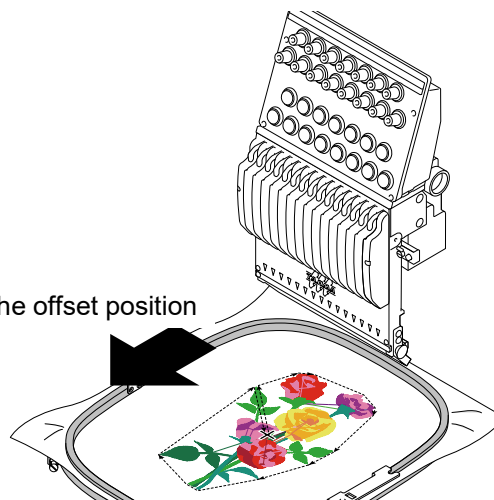

3. Making Use of DCP (TMBR2-SC)

The Digitally Controlled Presser Foot (DCP) is a function that uses a motor and digitally controls the presser foot to press the fabric.

It is possible to set the height and stroke of the presser foot according to the type and thickness of the fabric, which reduces the rattling of the fabric and achieves more stable sewing.

In addition, by using the touch panel, the DCP allows ease of presser foot adjustments, which operators needed to make manually.

3-1. Setting items for presser foot

Although presser foot settings are made with parameters in advance, you can change the following settings according to the type and thickness of the fabric.

■ Settings for presser foot lower dead point

Set the height from the needle plate to the presser foot lower dead point.

Make settings with consideration of the thickness of the fabric.

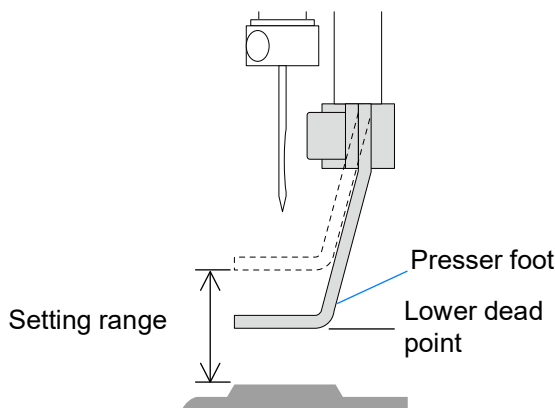

⚠ CAUTION

- Do not set the value lower than the thickness of the fabric. Doing so may cause the presser foot to come in contact with a part where the fabric is piled up and raised, and the machine may be damaged.

Setting range: 0.3 to 6.3 mm

■ Settings for presser foot stroke

Set the presser foot stroke.

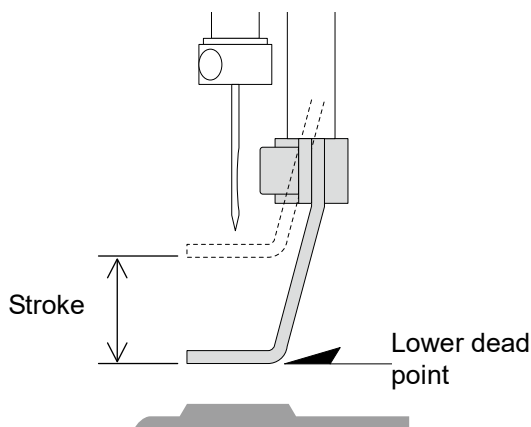

- If the stroke becomes larger, sewing mistakes can occur easily. Set the value by checking the sewing condition.

Setting range:

Functional limit level 1: 5.0 to 22.0 mm

Functional limit level 2, SEL: 2.0 to 22.0 mm

■ Settings for presser foot timing

Set timing when the presser foot starts to move down.

The smaller the setting value, the faster the moving down timing of presser foot. The larger setting value causes the delay of the timing.

The mutual relation among the lower dead point, the stroke, setting range of timing of the presser foot and the locus of the needle is shown roughly in the left figure as reference information.

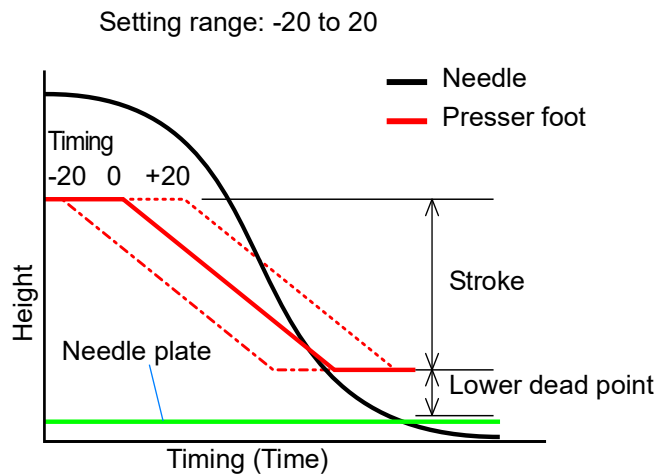
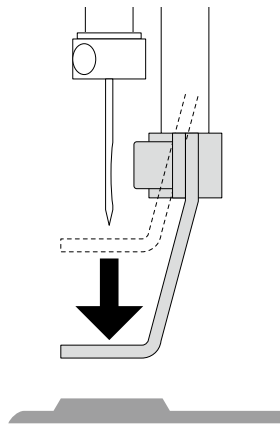

■ Settings for presser foot F. B. lower dead point

Set the height from the presser foot lower dead point to the presser foot (Height from the presser foot lower dead point) when performing Frame Back.

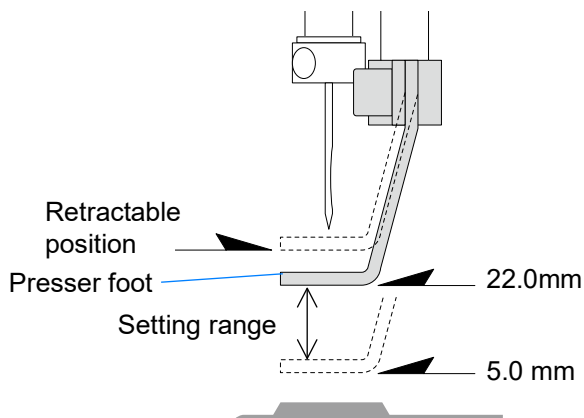

Setting range: 5.0 to 22.0 mm, R. (retracting position)

3-2. About Setting Operation

Presser foot settings are possible with any of the following three screens: Parameter setting screen, needle bar setting screen, and manual operation screen.

In the case of duplicated settings, those set in the needle bar setting screen will take precedence, followed by those set in the parameter setting screen or manual operation screen.

■ Settings on parameter setting screen

Make presser foot settings that serve as the basis of the entire machine or specified needle bar.

These are basic settings, so the machine will continue sewing with the same settings regardless of design changes.

Initial settings are registered in advance with parameters.

Furthermore, if settings are made on the needle bar setting screen, settings on the needle bar setting screen take precedence over parameter settings.

■ Settings on needle bar setting screen

Make presser foot settings per step for the selected design.

You can make presser foot settings that vary with each step for the same needle bar.

Values set on the needle bar setting screen are saved in design data.

■ Settings on manual operation screen

You can change presser foot settings during embroidery.

Make presser foot settings for the entire machine or for the needle bar currently being used.

Like parameter settings, the machine will continue sewing with the same settings regardless of design changes.

Values set on the manual operation screen are saved as parameter settings.

3-3. Settings on needle bar setting screen

Make presser foot settings per step for the selected design. The set value will be stored in design data.

You can make the following presser foot settings on the needle bar setting screen: presser foot lower dead point, presser foot stroke, presser foot timing, and presser foot F.B. lower dead point.

The following example shows how to set the height of the “presser foot lower dead point”.

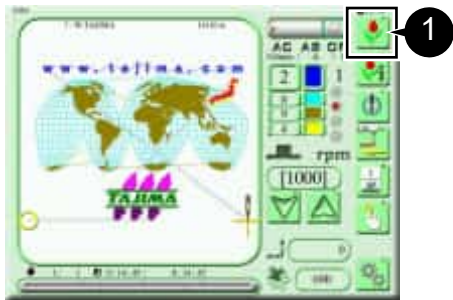

1 Press  on the main screen.

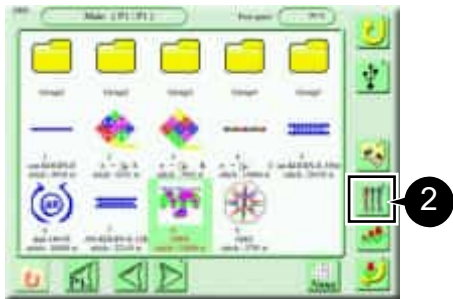

2 Press .

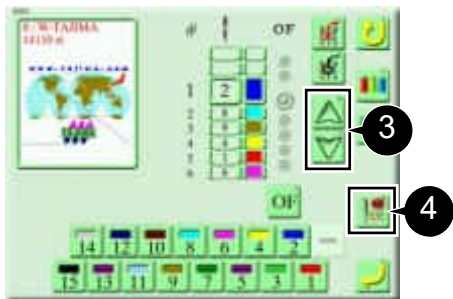

3 Press , and select the step.

4 Press .

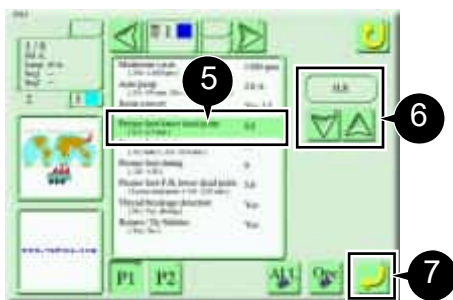

5 Select the “Presser foot lower dead point”.

6 Press , and set the height of the lower dead point.

7 Press .

3-4. Settings on manual operation screen

Make presser foot settings for the entire machine “Any” or for the needle bar currently being used.

Values set manually are saved as parameter settings for the entire machine.

You can make the following presser foot settings on the manual operation screen: lower dead point, stroke mode, stroke, timing, and F.B. lower dead point.

The following example shows how to set the height of the “lower dead point” of the needle bar currently being used.



- This operation cannot be operated when the functional limit level is set to “2”.

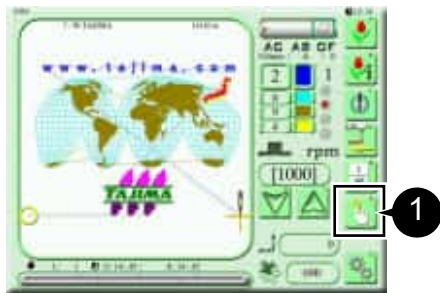

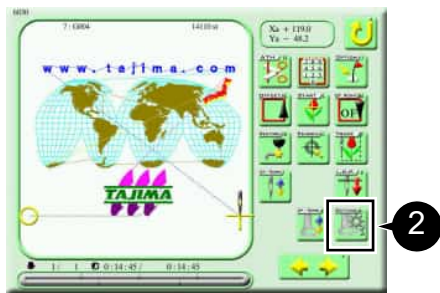

1 Press  on the main screen.

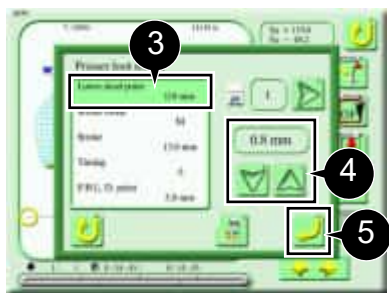

2 Press .



3 Select “Lower dead point”.

4 Press  , and set the height of the lower dead point.



- When making “Stroke” settings, first set the “Stroke Mode” to “M” (Manual).

5 Press .

4. Responding to Thread Breakage

4-1. How to respond to a thread breakage indicator

When a thread breakage is detected, the machine automatically stops and a message screen appears on the operation panel (OP).

How to respond to a thread breakage differs depending the error No. displayed.

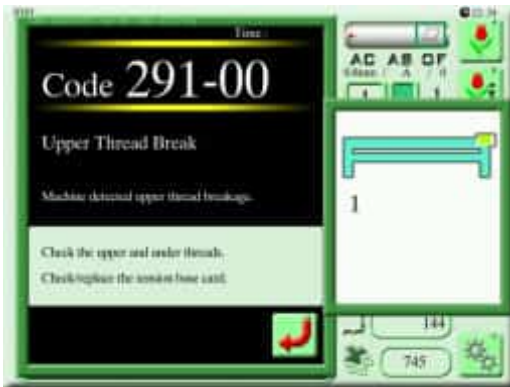

Display	Condition	Troubleshooting
Error No. 291	Upper thread breakage	Pass the broken upper thread through the needle.
Error No. 293	Under thread breakage	Remove the bobbin from the rotary hook and check the condition of the under thread. If the under thread is lost, replace the bobbin with new one.



- Once you pass the upper thread or replace the under thread and resume embroidery, the message screen disappears.

4-2. Repair stitches

During the period between when a thread breakage occurs and when the machine stops, the frame advances without the thread by several stitches and thus a part of embroidery goes missing. To resume embroidery after a thread breakage, move back the frame from the position where it was stopped and resume embroidery at such a position that the seams overlap a little for better finishing.

■ An overview of repair stitches

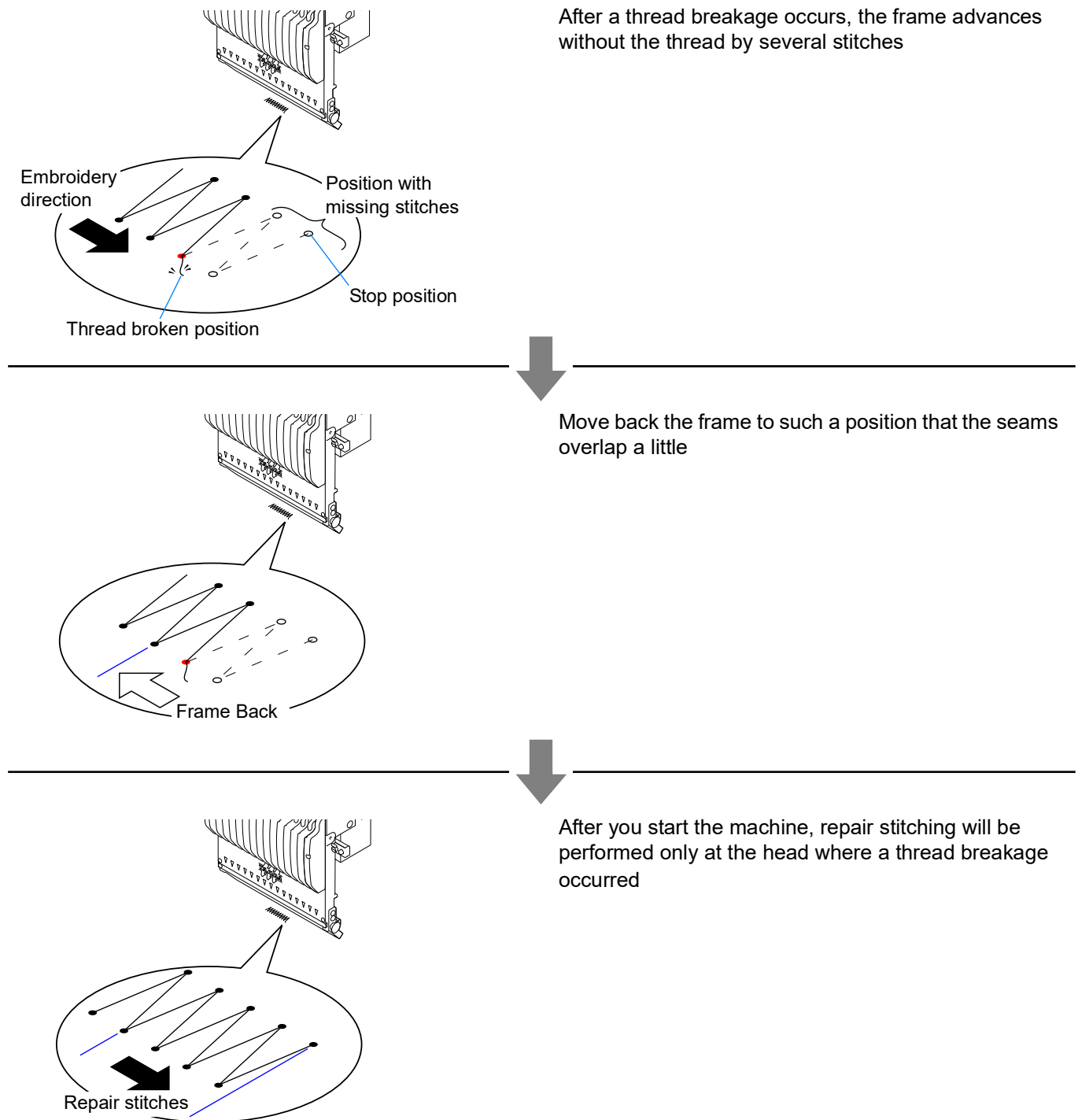

- If the "Auto F.B. after T. Detection" parameter is set to "Yes", the frame automatically moves back after a thread breakage. For details, refer to the separate "Parameter Settings" manual.

■ How to operate

The following example shows how to embroider after moving back the frame.

⚠ CAUTION

- ⊘ Do not put your hands near the needles or on the table when you operate the machine because doing so may cause your finger or hand to be injured when the needle bar or frame moves.

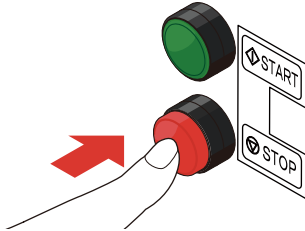

- 1 Keep pressing the stop switch to move back the frame to such a position that the seams overlap a little.



- For more information on moving back the frame (Frame Back), refer to "Chapter 3 1. Moving Back or Moving Forward the Frame Along the Stitches".

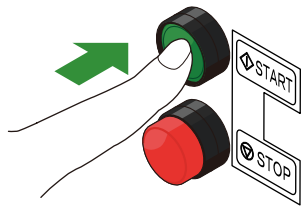

- 2 Press the start switch.
The machine starts up and performs return stitching and repair stitching.

1

2

3

4

5

6

7

8

9

Chapter 3

Manual Operation

1. Moving Back or Moving Forward the Frame Along the Stitches

You can move back (Frame Back) or forward (Frame Forward) the frame along the stitches with the needle bar stopped.

This feature is useful when you want to:

- Resume embroidery from a stitch before the position where a thread breakage occurred for the purpose of performing repair stitching after a thread breakage.
- Resume embroidery from within the design or from an intermediate step
- Skip an area within the design or an intermediate step

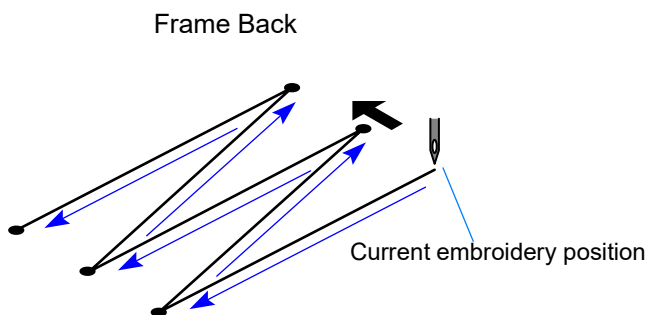

The frame will be moved to the direction where stitches return with the needle bar stopped.

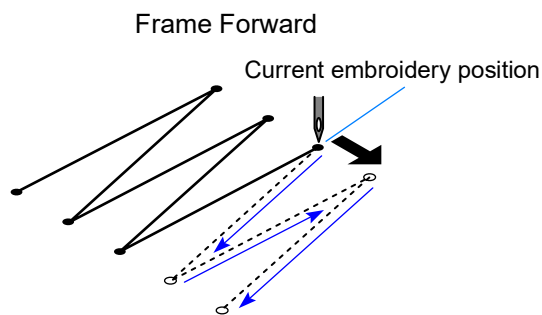

The frame will be moved to the direction where stitches advance with the needle bar stopped.



You can use the Frame Back and Frame Forward features in one of the following three ways.

Method	Unit	Detail
Stop switch	Stitch	Move back/forward the frame on a stitch by stitch basis along the stitches.
Operation panel (OP)		Move back/forward the frame across the stitch count you specify.
Operation panel (OP)	Color change	Move back/forward the frame by the number of color change codes you specify.

1-1. Frame back/frame forward operation screen

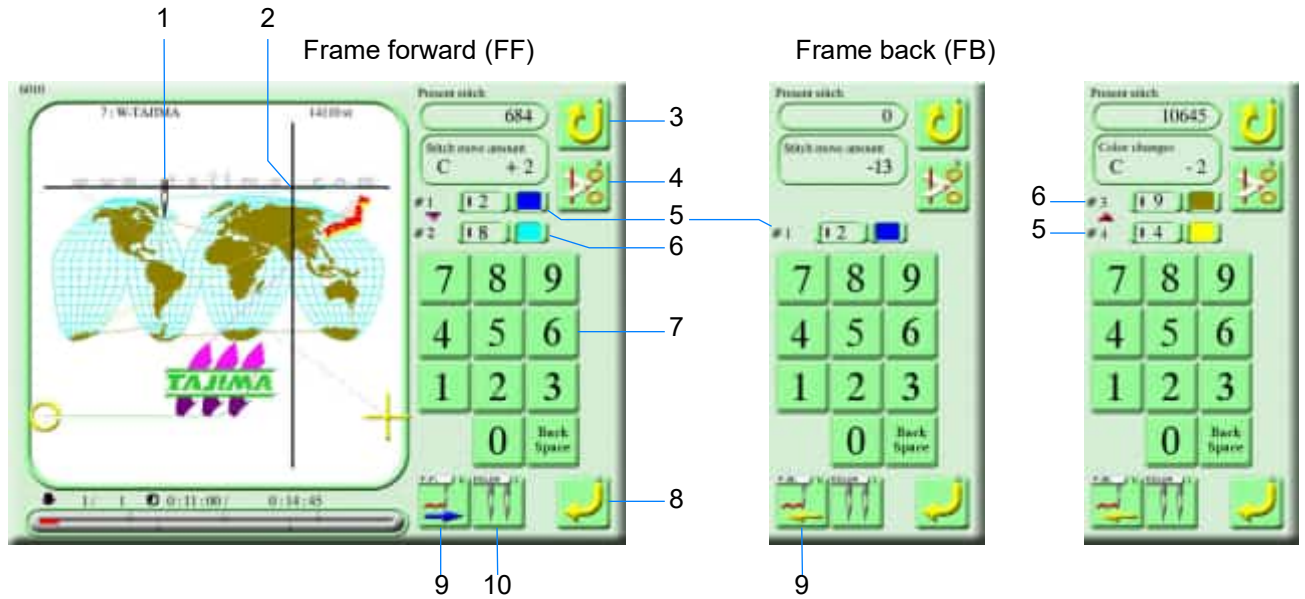
This screen shows the switching of frame back/frame forward and executing frame back/frame forward to a specified number of stitches or color change position.



No.	Description	No.	Description
1	FB/FF destination needle position	7	Numerical key (enter the number of stitches for the amount of movement)
2	Current needle position	8	Execute FB/FF move
3	Back (return to the previous screen)	9	 : Frame Back  : Frame Forward (The icon switches each time you press it)
4	Thread trimming		
5	Current needle bar step number/needle bar number/thread color If the destination of FB/FF is the same needle bar step, the destination step information is not displayed.	10	Move to the next needle bar step
6	Number of needle bar steps of FB/FF destination/needle bar number/thread color		

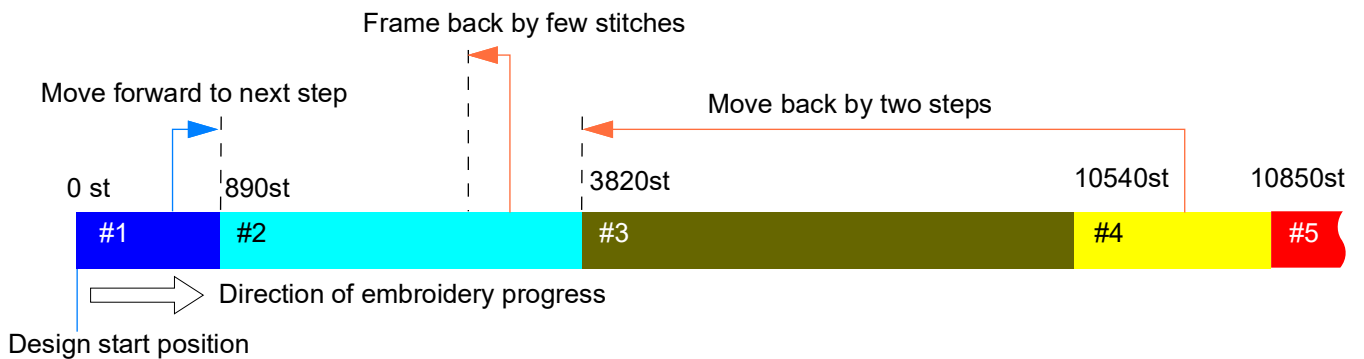



1-2. Frame Back/frame Forward by 1-stitch unit

You can use the stop switch to move back or forward the frame on a stitch by stitch basis.

⚠ CAUTION

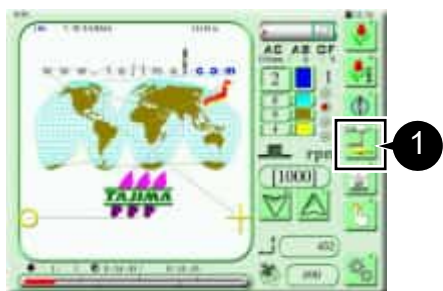
⊘ Do not put your hands on the table when you operate the machine because doing so may cause your finger or hand to be injured when the frame moves.



1 Press  on the main screen.



2 Select the direction in which to feed the frame.



: Frame Back



: Frame Forward

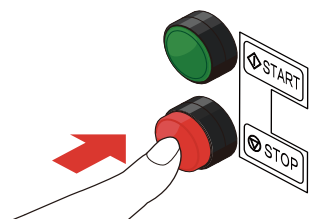

3 Press the stop switch and hold it in that position.
The frame moves on a stitch by stitch basis along the stitches.

4 Release the stop switch when the frame moves to the desired frame position (within 10 stitches).
The frame stops moving.

■ High-speed travel of Frame back/Frame Forward

Hold down the stop switch on hold for 11 or more stitches switches to high-speed travel (feed unit). To stop high-speed travel, release the switch once and press the stop switch.

In this mode, you can configure the frame feed amount for high-speed travel. For details, refer to the separate "Parameter Settings" manual.

[Frame Back]

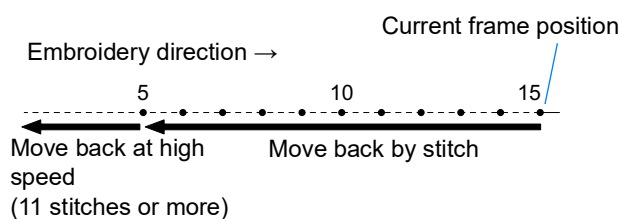

[Frame Forward]

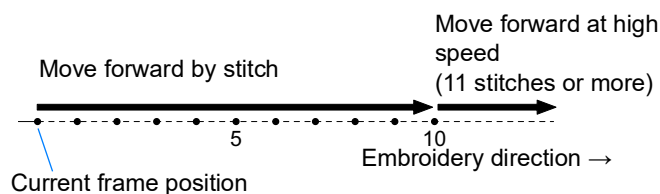

1-3. Frame Back/Frame Forward by specifying the number of stitches

You can move back or forward the frame by the number of stitches you specify.

CAUTION

-  Do not put your hands on the table when you operate the machine because doing so may cause your finger or hand to be injured when the frame moves.

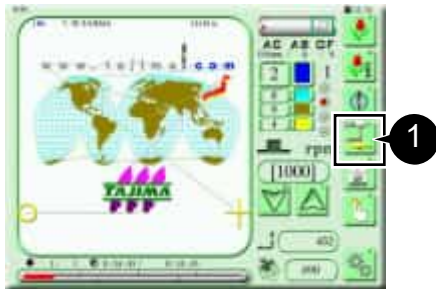

- 1 Press  on the main screen.

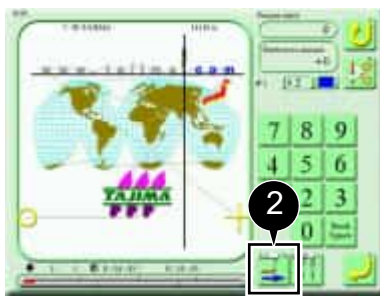

- 2 Select the direction in which to feed the frame.



: Frame Back



: Frame Forward

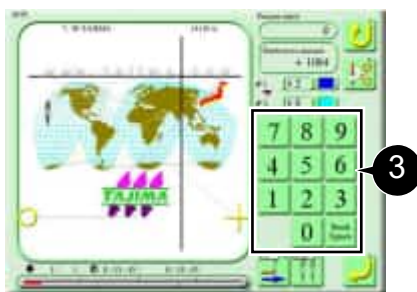

- 3 Input the number of stitches (for example, 500).

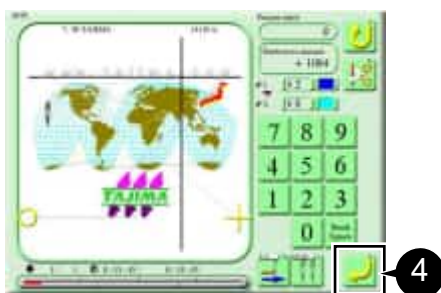

- 4 Press .

The frame moves along the stitches by the specified number of stitches.

1-4. Frame Back/Frame Forward by specifying the number of color change

You can move back or forward the frame by the number of color changes you specify.

CAUTION

 Do not put your hands on the table when you operate the machine because doing so may cause your finger or hand to be injured when the frame moves.



1 Press  on the main screen.

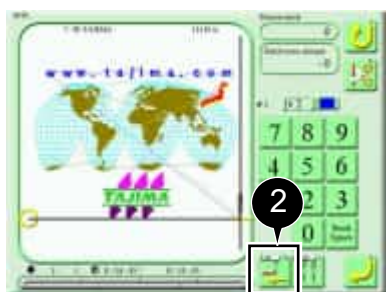

2 Select the direction in which to feed the frame.

 : Frame Back

 : Frame Forward

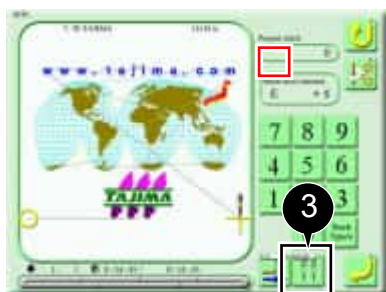

3 Press  as many times as the desired number of color changes.



- When moving forward, the last code is displayed as "E" (red frame).



4 Press .

The frame moves along the stitches by the specified number of color changes.

2. Thread Trimming

2-1. Operating the ATH

You can trim under thread or both the upper and under threads.

⚠ CAUTION

⊘ Do not put your hands near the needles or on the table when you operate the machine because doing so may cause your finger or hand to be injured when the needle bar and the frame moves.

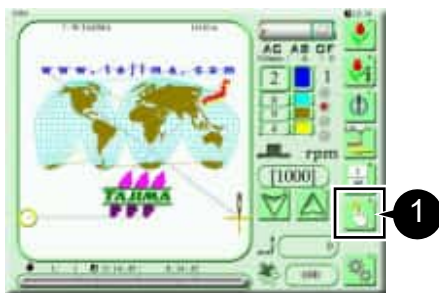

1 Press  on the main screen.

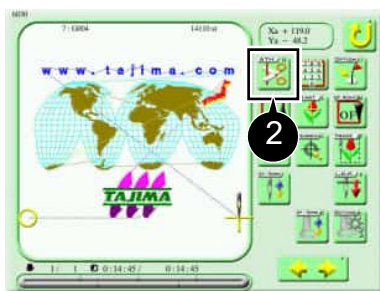

2 Press .



3 Execute thread trimming.

 : Under thread

 : Upper thread and under thread

3. Needle Bar Related Operations

3-1. Color Change

A color change is performed by sliding the needle bar case and switching the needle bar at the sewing needle to a different needle bar.

⚠ CAUTION

⊘ Do not bring your hand close to the needle bar case when you operate the machine because doing so may cause your finger or hand to be injured when the needle bar case moves.



- If the thread is connected to the fabric, trim the thread before the color change.
- If you manually switch the needle bar and want to use the new one for embroidery, set the “Auto Color Change (AC)” parameter to “NO”.
For details, refer to the separate “Parameter Settings” manual.

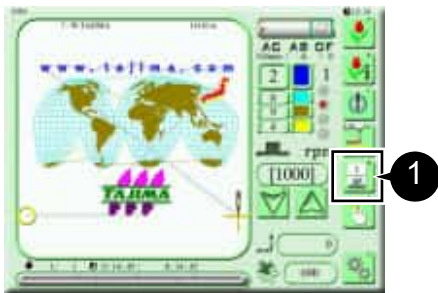

1 Press  on the main screen.

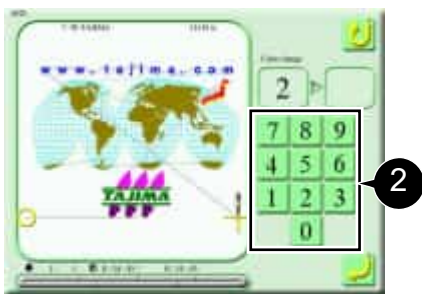

2 Select the new needle bar No. (for example, needle bar No. 8).

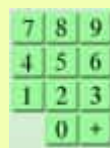

• When equipped with a laser cross marker, specify “+” to change the color to the laser cross marker.

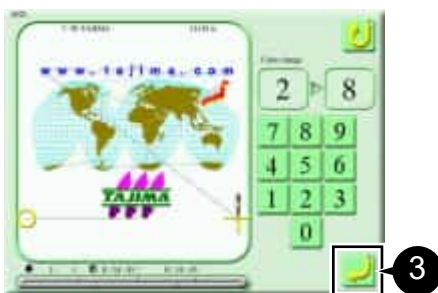

3 Press .

The needle bar case slides and the needle bar switches to the new one.

3-2. Raising or lowering the needle bar

You can lower/raise the selected needle bar once (1 stitch dropping), lower or raise the selected needle bar.

CAUTION

 Do not put your hands near the needles when you operate the machine because doing so may cause your finger or hand to be injured when the needle bar raises or lowers.

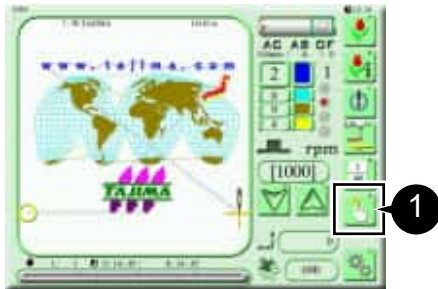

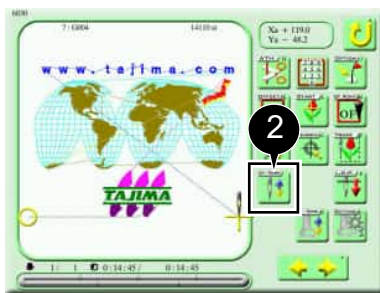

1 Press  on the main screen.

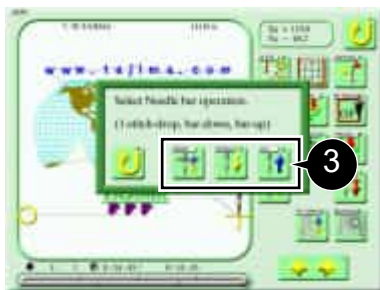

2 Press .



3  : Lower/raise the needle bar once

 : Lower the needle bar

 : Raise the needle bar

3-3. Stopping the needle bar at the lower dead point

You can lower the selected needle bar to the lower dead point.



- Since the needle bar lowers to the lower dead point, the needle remains penetrating the fabric. This feature is useful when you embroider consecutively on the long fabric.

CAUTION

- Do not put your hands near the needles when you operate the machine because doing so may cause your finger or hand to be injured when the needle bar lowers.

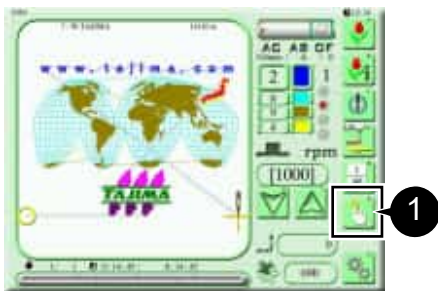

1 Press on the main screen.

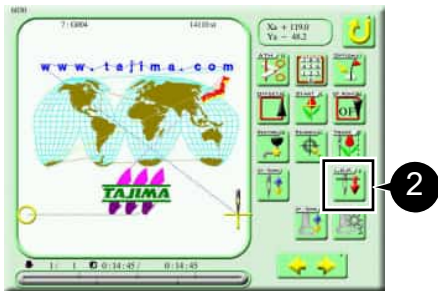

2 Press .



3 Press .
The needle bar lowers to the lower dead point.

3-4. Raising or lowering the presser foot (TMBR2-SC)

You can lower or raise the selected needle bar presser foot.

CAUTION

-  Do not put your hands near the needles when you operate the machine because doing so may cause your finger or hand to be injured when the presser foot raises or lowers.

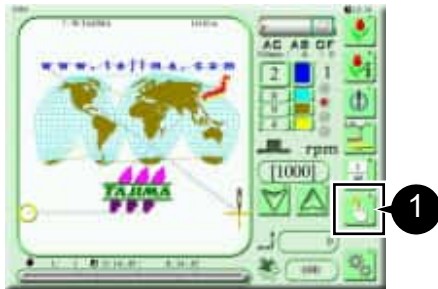

- 1 Press  on the main screen.

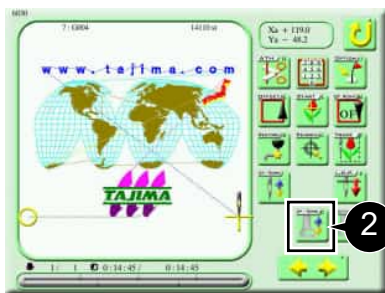

- 2 Press .

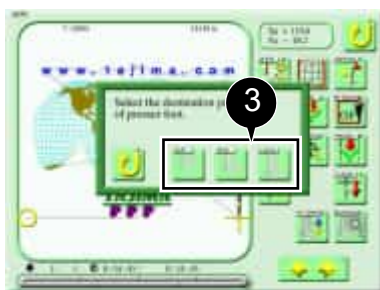

- 3 Raise or lower the presser foot.



: Retracting position



: Frame Back Position



: Lower dead point of presser foot

4. Various Frame Movement Operations

4-1. Moving the frame to the preset optional position

You can move the frame to a preset optional position.



- For more information on presetting a frame position, refer to the separate "Parameter Settings" manual.

CAUTION

-  Do not put your hands on the table when you operate the machine because doing so may cause your finger or hand to be injured when the frame moves.

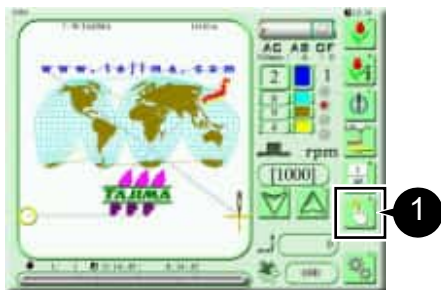

- 1 Press  on the main screen.

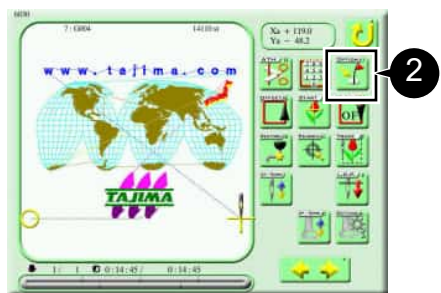

- 2 Press .

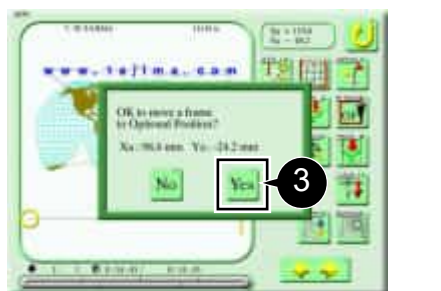

- 3 Press .
The frame moves to the preset optional position.

4-2. Moving the frame to the original position (manual offset)

You can move the frame to the original position after you have moved it manually during embroidery.

⚠ CAUTION

- ⊘ Do not put your hands on the table when you operate the machine because doing so may cause your finger or hand to be injured when the frame moves.

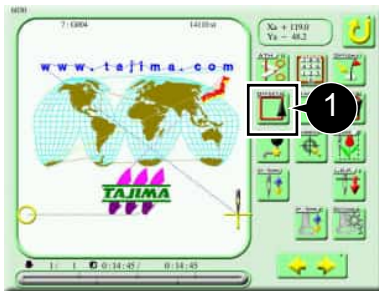

- 1 Press  on the manual operation screen.

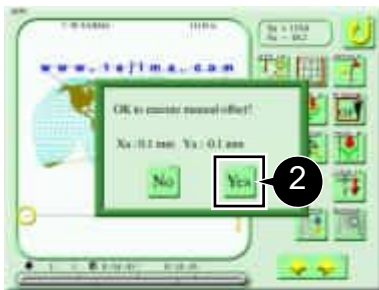

- 2 Press .
The frame moves to the original position.

4-3. Moving the frame to the start position

You can move the frame to the start position.

⚠ CAUTION

- ⊘ Do not put your hands on the table when you operate the machine because doing so may cause your finger or hand to be injured when the frame moves.

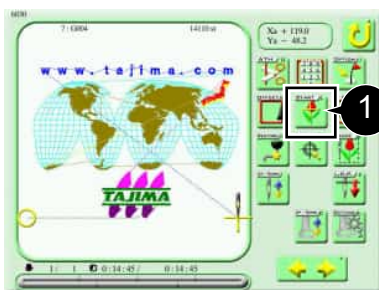

- 1 Press  on the manual operation screen.



- 2 Press .
The frame moves to the start position.

4-4. Moving the frame to the offset position

You can move the frame to the offset position.

The offset position is a position where the frame is automatically moved (offset toward you) during and after embroidery and put into standby for ease of replacing the frame or fabric.



- To move the frame to the offset position, you must preset it. For details, refer to "Chapter 6 1-2. Registration of the Offset Position".

CAUTION

-  Do not put your hands on the table when you operate the machine because doing so may cause your finger or hand to be injured when the frame moves.

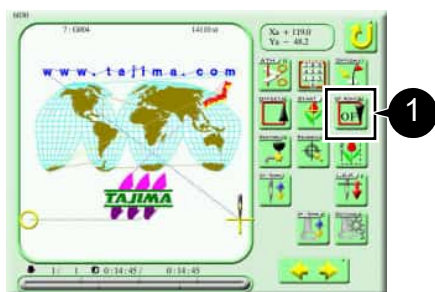

- 1 Press  on the manual operation screen.

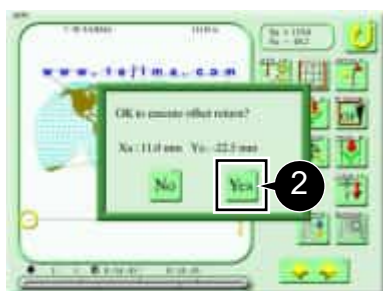

- 2 Press .
The frame moves to the offset position.

4-5. Moving the frame by entering a numeric value

You can move the frame by entering a numeric value.





- The value you enter is the amount of travel from the current frame position.

⚠ CAUTION

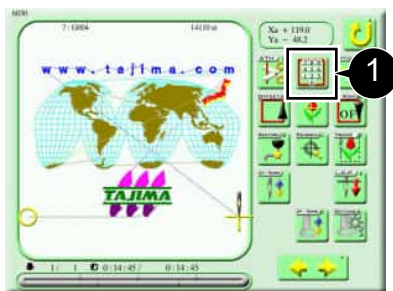

Do not put your hands on the table when you operate the machine because doing so may cause your finger or hand to be injured when the frame moves.



- Press  on the manual operation screen.



- Pressing the coordinate icon will change the indication.

- Current frame position

$Xa + 19.2$
 $Ya + 98.7$: Based on absolute origin

$Xr + 0.0$
 $Yr + 0.0$: Based on the start position

- Frame Travel amount from current frame position

$Xm - 20.0$
 $Ym + 15.0$: Travel amount you enter

Xm - (minus sign): Frame moves to right

+ (plus sign): Frame moves to left

Ym - (minus sign): Frame moves to rear

+ (plus sign): Frame moves to front



- Press $Xm + 0.0$.

- Enter the X-axial travel amount (for example, +60.0).



- Press $Ym + 0.0$.

- Enter the Y-axial travel amount (for example, -85.0).

- Press .

The frame moves to the specified position.

4-6. Absolute origin search

Be sure to execute absolute origin search after you have moved the frame by hand with the power OFF.





The absolute origin of the frame is a reference point ($X_a = 0.0$, $Y_a = 0.0$) to calculate the current frame position. If the absolute origin is not correctly registered, the following problems may occur.

- The frame coordinates are not displayed correctly.
- After emergency stop or power failure, turning ON the power fails to return the frame to the position where the operation was suspended.

CAUTION

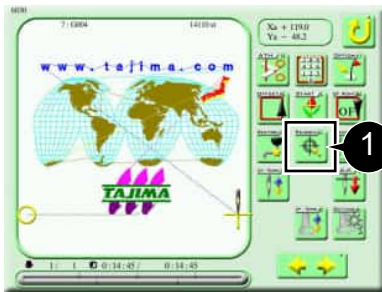
- Do not put your hands on the table when you operate the machine because doing so may cause your finger or hand to be injured when the frame moves.



- 1 Press  on the manual operation screen.

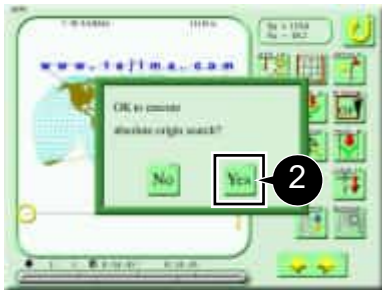

- 2 Press  .
The frame will move to the absolute origin and return to the original position.

4-7. Power Resume

You can return the frame to the position where it was when the power was turned OFF.



- If you moved the frame by hand with the power OFF during embroidery and now want to return it to the original position, turn ON the power and manually perform power resume. This feature requires that the absolute origin of the frame is correctly registered.

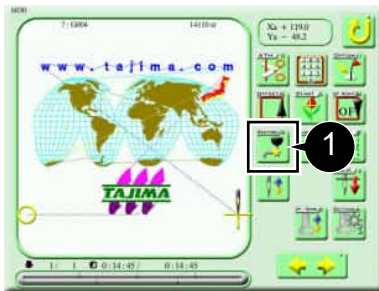

1 Press  on the manual operation screen.



2 Select the power resume method.



: Perform power resume after trimming the thread.



: Perform power resume without trimming the thread.



- When you perform power resume, the machine checks the absolute origin and the frame moves to a position several stitches back from the position where it was when the power was turned OFF.

5. Other Operation

5-1. ATH cleaning mode

Open the ATH movable knife.

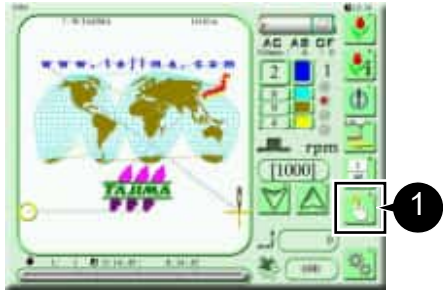

1 Press  on the main screen.

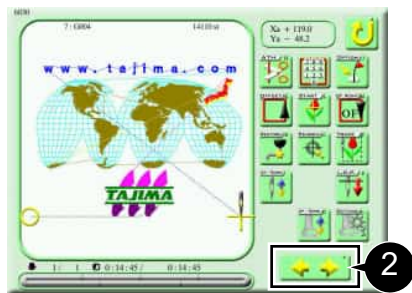

2 Press .



3 Press .



4  Open movable knife

For cleaning ATH, refer to "Chapter 7 3-1. Inside of the cylinder bed"



5 Press .

The screen will return to the previous screen by one.

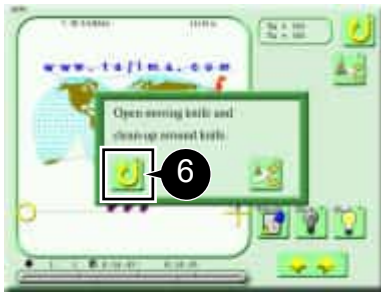

6 Press .

The movable knife closes and the ATH cleaning mode ends.

5-2. Turning ON/OFF the LED lamp

You can turn ON/OFF the LED lamp.

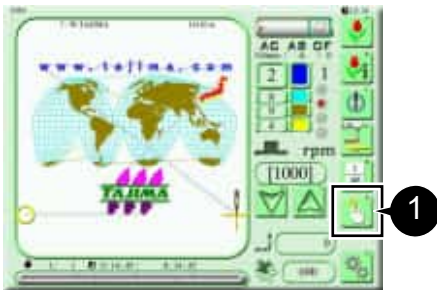

1 Press  on the main screen.

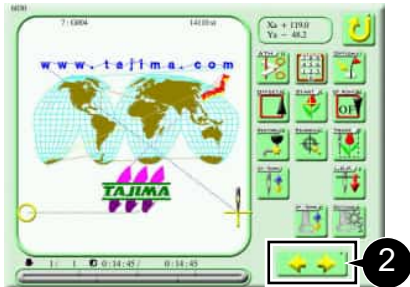

2 Press .



3 Turn ON/OFF the LED lamp set.

 : Turn OFF

 : Turn ON

5-3. Needle bar active/suspended

This setting allows the needle bar active or suspended when the machine is started. The frame will drive even when the needle bar is suspended.

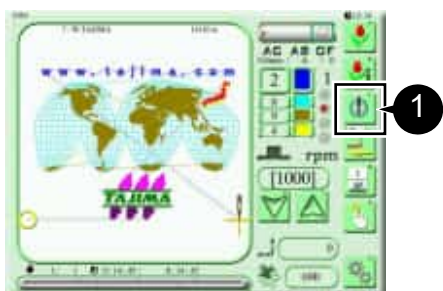

1 Press  on the main screen.

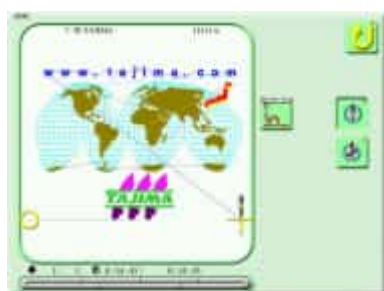

2 Select active/suspended needle bar.



: Needle bar is active



: Needle bar is suspended



: Forced Return Stitches



- Forced return stitches perform return stitching at the first needle.

Chapter 4

Design Management

1. Inputting/Outputting Designs

This function allows you to input a design from an external source into the machine memory, or to save a design in the machine memory to USB memory.

1-1. From the machine memory to a USB memory

To save designs from the machine memory to a USB memory, use the following steps.

The following example shows how to select two designs and store them as "T3" data in a USB memory.



- This feature is only available if the functional limit level is set to "SEL".

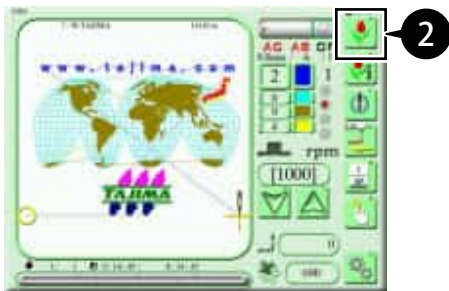

1 Insert a USB memory into the USB port of the operation panel.

2 Press  on the main screen.



3 Select the first design you want to save.

4 Press .



- Press  to select all the designs.

- Press  to deselect all the designs.



5 Select the second design you want to save.

6 Press .



7 Press  .



- If you want to save the design without changing the file name, skip to step 9.

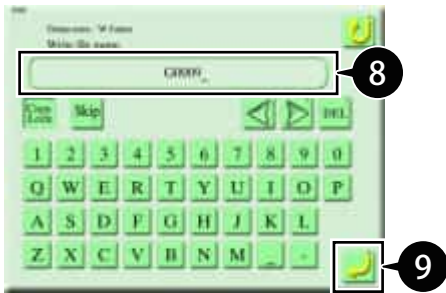

8 Change the file name of the first design you want to save.

(For example, change to "G0009".)



- Enter up to 20 alphanumeric characters. The file name you enter will be displayed on your PC ("G0009.TCF" in this example).

9 Press  .

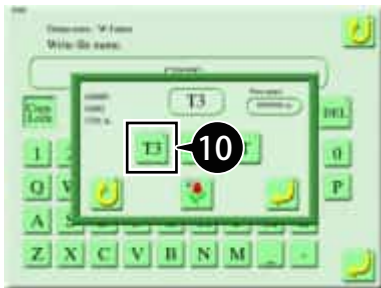

10 Press  .



- Usually, select  . For more information on the storage format, refer to "Chapter 2 2-1. Saving or Storing designs into the machine memory".

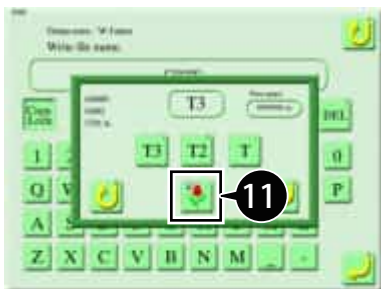

11 Select the storage format.



: Specify the storage format for each design you save.



: Save the selected designs in the same storage format.

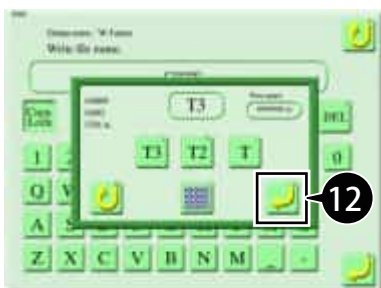

12 Press  .



- If you want to save the design without changing the file name, skip to step 14.

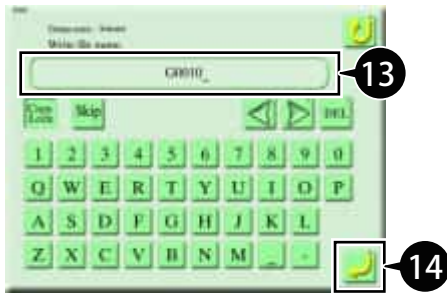

13 Change the file name of the second design you want to save.
(For example, change to "G0009".)

14 Press .
The designs are saved in a USB memory.

■ About the design display on your PC

When you read the designs saved in a USB memory (for example, file name "G0003") into your PC, they are displayed as follows:

Saving format	Display on your PC	Use
T3 (TCF)*1	G0003.TCF	Data integrating T2 (CT0, DGF, TBF) and CT1 The following conditions are included in CT1. Message S Message E
T2 (TBF)*2	G0003.CT0	Condition data (color change sequence, start position)
	G0003.DGF	Thumbnail data
	G0003.TBF	Stitch data in TAJIMA binary format
T (DST)	G0003.DST	Stitch data in TAJIMA ternary format

*1: The T3 format consists of the following four sets of data combined into a single file:

TBF (TAJIMA binary format)	CT0 (Condition data)
DGF (Thumbnail data)	CT1 (Message)

*2: The T2 format consists of the following three sets of data but they are not combined into a single file.

TBF (TAJIMA binary format)	CT0 (Condition data)
DGF (Thumbnail data)	

1-2. How to connect the machine to your PC

Sample model

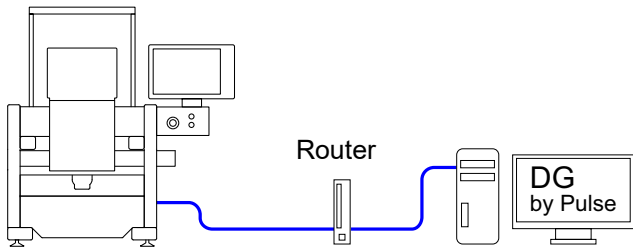

- 1 Turn OFF the PC, router, and machine and connect the LAN between the PC and machine.



- To connect the machine via a router to your PC, use a straight cable available on the market.

- 2 Turn ON the router.
- 3 Turn ON the PC and start "DG by Pulse".
- 4 Turn ON the machine.

- 5 Press  on the main screen.



- To use this feature, enter the password to set the functional limit level to "SEL".

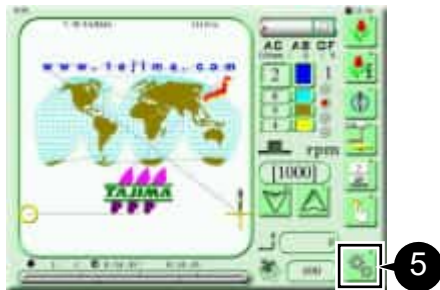

- 6 Press .

- 7 Select "78. Optional device (software)".

- 8 Press .

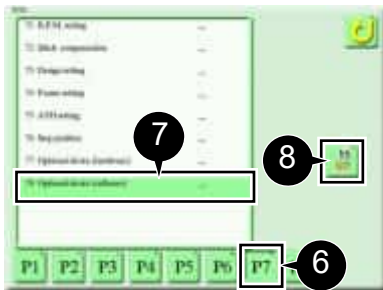

- 9 Select "1. Network".

- 10 Press .

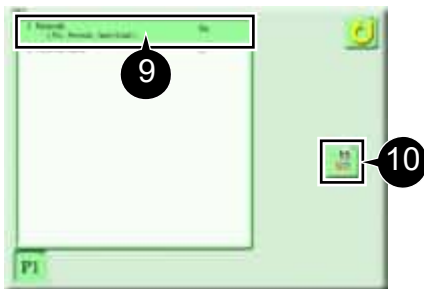

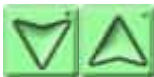
- 11 Press  next to "Network" and select "DG/ML[V-]".

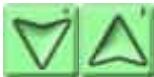
- 12 Press  next to "IP address" and select "Auto".



13 Press .

Various addresses are automatically acquired.



- If automatic acquisition fails, check the LAN cable connection, operating steps, and the settings of DG by Pulse.





14 Press .

The machine and PC are connected.



- Once the network connection is established, an icon (red frame) indicating the network connection will appear on the main screen.

-  Normal connection
-  Confirming connection
-  Connection failure

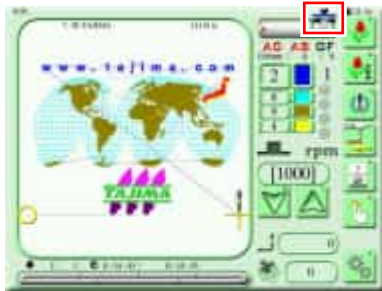

1-3. From PC to the machine memory

The following example shows how to specify designs saved on the PC and store them into the machine “Main” memory.

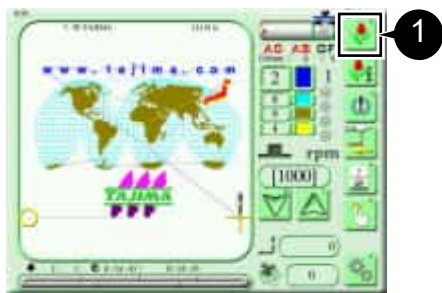

1 Press  on the main screen.

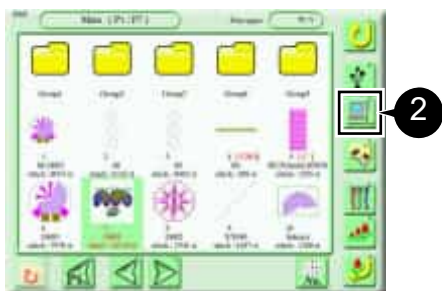

2 Press .
 Designs stored in DG by Pulse are displayed.



- If an icon  is displayed, it means that DG by Pulse is not connected to your PC. Refer to "Chapter 4 1-2. How to connect the machine to your PC" and connect it to your PC.



3 Select a design.

4 Press .



5 Press  “Main”.
 The process of storing the design completes.

1-4. From PC to the machine memory (Barcode reader)

Once you read a barcode through a barcode reader, the design is stored in the machine memory and the data is automatically set.

If you read multiple barcodes, the last design data is set.



- You can create barcodes using the print function of DG by Pulse. For more information, refer to the user's manual for DG by Pulse.
- Use a USB-connectable barcode reader available on the market.

Barcode reader

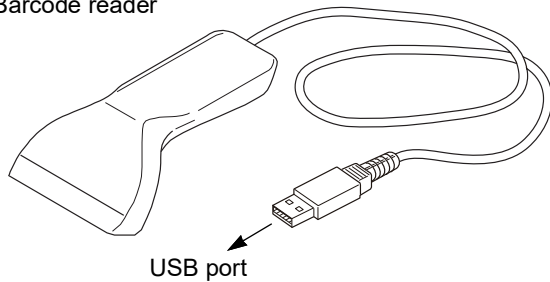

- 1 Insert the barcode reader into the USB port on the operation panel (OP).

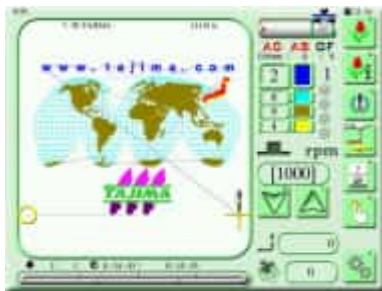

- 2 Display the main screen.



- You can read barcodes also from the following screen numbers.
No. 2000, No. 4100, No. 4150

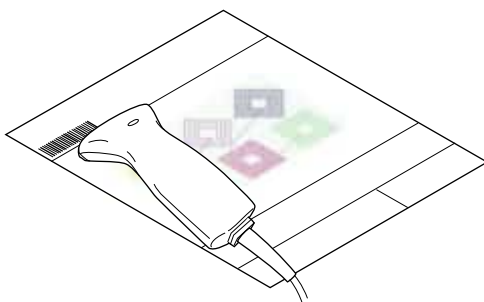

- 3 Read the barcode by using the barcode reader.
The design data is set.



- If you repeatedly read the same barcode, as many times as you read will be stored in the machine memory.

[If you read a barcode during embroidery]

During embroidery, you can pre-read the next embroidery design using the barcode reader.



- You can pre-read only one design.
- If you read multiple barcodes during operation, the last design you read will be selected.
- When suspending to embroider a design during operation and setting the data of another design, the pre-read design will be deleted.
- When suspending to embroider some design during operation and to perform the data setting of the pre-read design, read the barcode again.

2. Deleting Designs

This section describes how to delete designs in the machine memory.

2-1. Deleting a design in the machine memory (one design at a time)

To delete one design at a time, use the following steps.

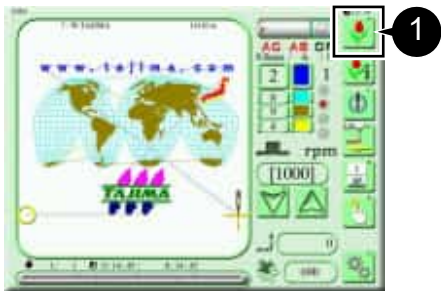

1 Press  on the main screen.

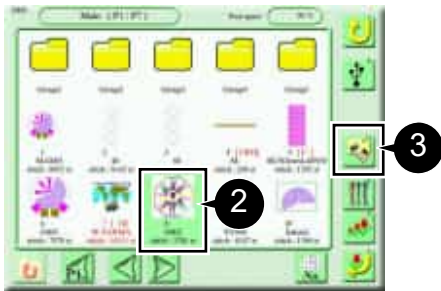

2 Select the design you want to delete.

3 Press .

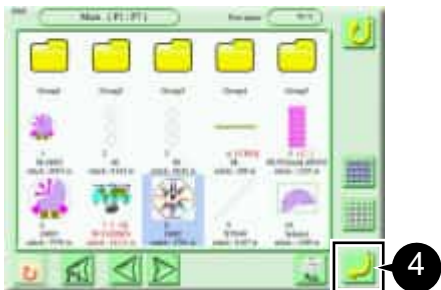



-  Select all designs
-  Deselect all designs

4 Press .



5 Press .



6 Press .

The deletion is performed.



- If you delete the design whose data is set, you cannot continue embroidery.

2-2. Deleting designs in the machine memory (two or more designs at once)

To delete two or more designs at once, use the following steps.

The following example shows how to delete two selected designs at once.



- If the designs you want to delete belong to different layers, delete them for each layer.

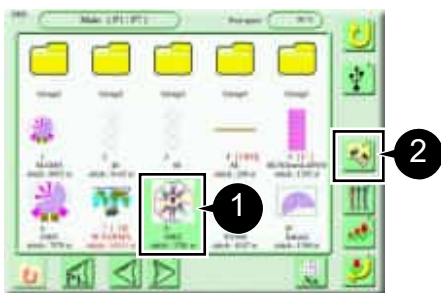

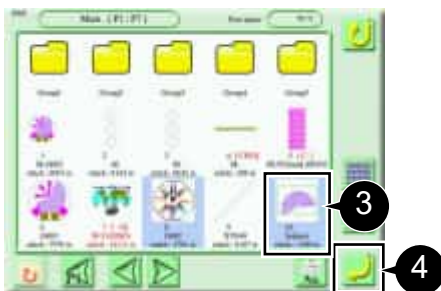

1 On the design selection screen, select the first design you want to delete.

2 Press .



3 Select the second design you want to delete.



-  Select all designs
-  Deselect all designs

4 Press .



5 Press .



6 Press .

The deletion is performed.



- If you delete the design whose data is set, you cannot continue embroidery.

2-3. Deleting designs in the USB memory

To delete designs in the USB memory, use the following steps.
The following example shows how to delete two selected designs.



- If the designs you want to delete belong to different layers, delete them for each layer.

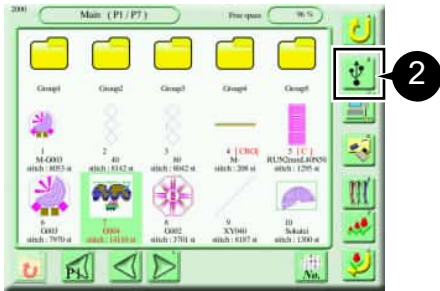

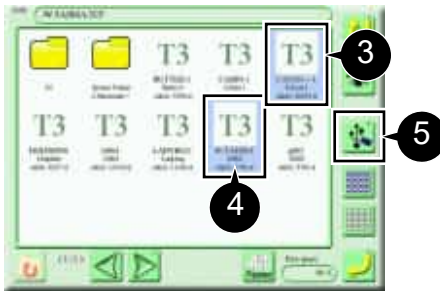

1 Insert a USB memory containing designs into the USB port on the operation panel (OP).

2 Press .



3 Select the first design you want to delete.



-  Select all designs
-  Deselect all designs

4 Select the second design you want to delete.

5 Press .

6 Press .

The deletion is performed.

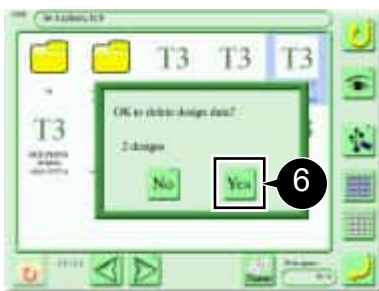

3. Changing the Design Name and Storage Location

This function allows you to change the name of design and design storage location in the machine memory.

3-1. Changing a design name.

To rename a design saved in the machine memory one by one, use the following steps.

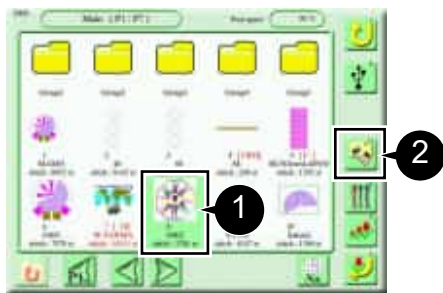

1 Select the design you want to rename on the design selection screen.

2 Press .

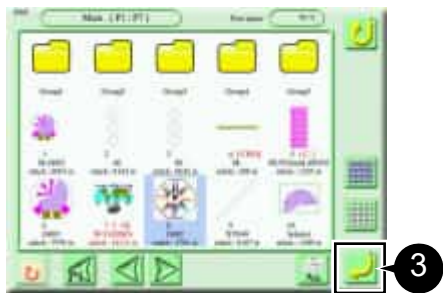

3 Press .



4 Press .

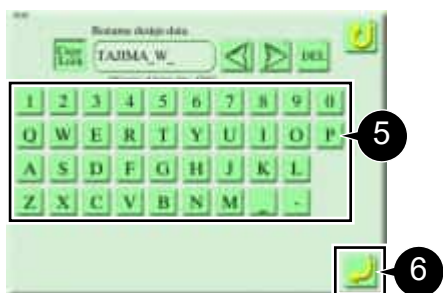

5 Enter the new design name.



• You can enter a design name up to 8 characters long.

6 Press .

The design is renamed.

3-2. Changing the design storage location

To move designs to a different storage location in the machine memory, use the following steps. The following example shows how to select two designs and move them to the "Group2" folder.

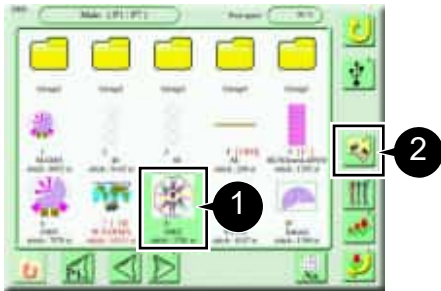

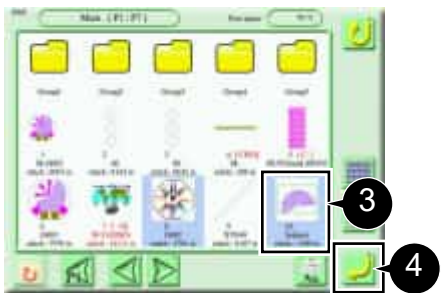

1 On the design selection screen, select the first design you want to move.

2 Press .



3 Select the second design you want to move.



-  Select all designs
-  Deselect all designs

4 Press .



5 Press .



6 Press  "Group2".

The designs are saved in the "Group2" folder.

1
2
3
4
5
6
7
8
9

Chapter 5

Editing Needle Bar Steps and Designs

1. Editing Needle Bar Steps

You can change embroidery conditions (such as the needle bar No. and RPM) for each needle bar step you specify.



- For items overlapping with the setting value of a machine parameter, the value here will take priority.

1-1. Setting needle bar step embroidery conditions

The following example shows how to change the embroidery conditions for needle bar step 5 by changing the needle bar No. from 1 to 9 and changing the RPM limit from 1200 rpm to 700 rpm.

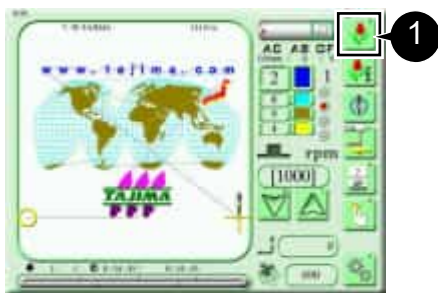

1 Press  on the main screen.



2 Select your desired design.

3 Press .

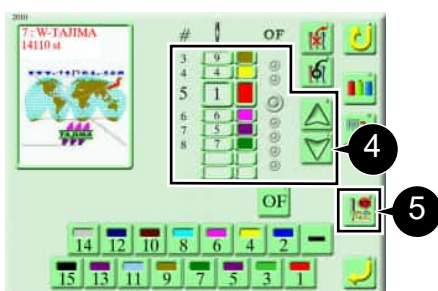

4 Press  to select the needle bar step 5.

5 Press .

1. Editing Needle Bar Steps

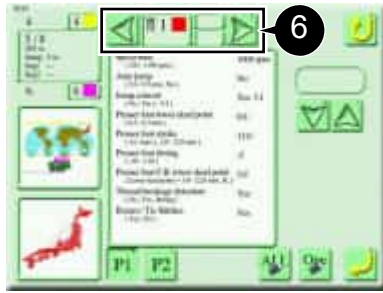

6 Press  and select the needle bar No. 9.



7 Select "Speed limit".





8 Press  and select "700 rpm".

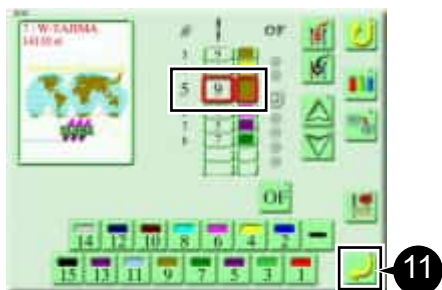

9 Press .
The embroidery conditions are changed.

10 Press .



11 Press .
The needle bar step whose embroidery conditions have been changed is highlighted in a red frame.

■ Detail of the settings screen

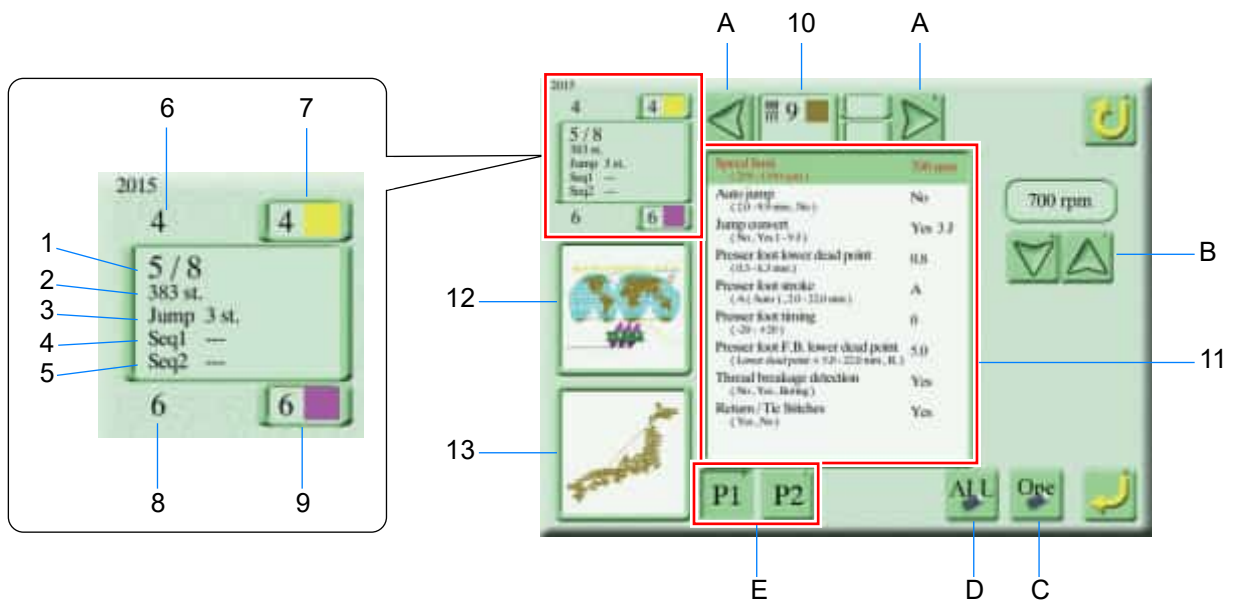

No.	Description	No.	Description
1	Currently selected step / Total number of steps in the design	10	Display of the needle bar No. and thread color for the currently selected step
2	Number of stitches in the step	11	Display of embroidery conditions (changed items are highlighted in red)
3	Number of jump codes in the step	12	Display of entire design
4	Number of sequin output 1 in the step	13	Enlarged view of the portions embroidered for the currently selected step
5	Number of sequin output 2 in the step	A	Change the needle bar No.
6	Previous step	B	Change the value
7	Display of the needle bar No. and thread color for the previous step	C	Initialize the value of the changed item
8	Next step	D	Initialize all the changed items
9	Display of the needle bar No. and thread color for the next step	E	Switch the screens (between P1 and P2)

■ Embroidery condition items

P1

Embroidery conditions	Setting range
Revolution Limit	250 rpm to Maximum rpm of machine
Auto Jump	2.0~9.9 mm, No
Jump Convert	No, Yes1~9J
Presser foot lower dead point	0.3~6.3
Presser foot stroke	A, 2.0~22.0
Presser foot timing	-20~+20
Presser foot F.B. lower dead point	Lower dead point +5.0 to 22.0, R.
Thread breakage detection	No, Yes
Return / Tie stitches	Yes, No

P2

Embroidery conditions	Setting range
Satin stitch (area) ^{*1}	Whole, part, No
Satin stitch (Density) ^{*1}	0.4~1.0 mm
Satin Stitch (Expansion) ^{*1}	-1.0~+1.0 mm
FS Mode	Yes, No

*1: Displayed only when the functional limit level is "SEL".



1-2. Repetition of needle bar steps

You can repeat needle bar steps.

Repeat from the first step to the step just before the repeat is executed.

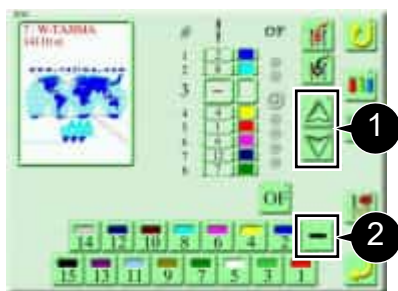
The following example shows how to repeat needle bar steps 1 and 2.



- 1 Press  and select the needle bar No. 3.
- 2 Press  and select repeat.

Perform repeat embroidery with the needle bars of needle bar step 1 to 2.



- To cancel a repetition, set the thread color in the repetition step.

1-3. Insertion of needle bar step

A new needle bar step is inserted after the specified needle bar step.

All the needle bar steps will follow the inserted one.

The following example shows how to insert a new needle bar step after the needle bar step 4.



1 Select your desired design on the design selection screen.

2 Press .

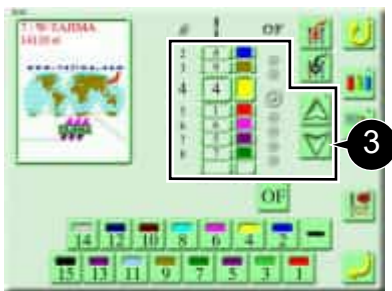

3 Press  to select the needle bar step 4.

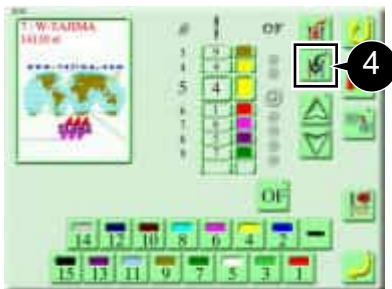

4 Press .

A new needle bar step is inserted.



- The inserted needle bar step is given the same needle bar No. as the one that precedes it. Change the needle bar No. as needed.

1-4. Deletion of needle bar step

You can delete your specified needle bar step.

All the needle bar steps after the deleted one will move up.

The following example shows how to delete the needle bar step 4.



1 Select your desired design on the design selection screen.

2 Press .

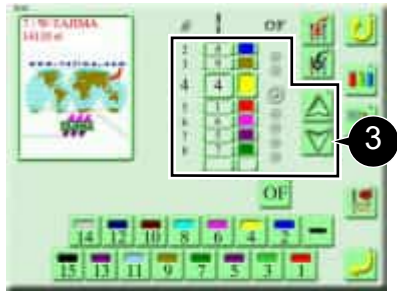

3 Press  to select the needle bar step 4.

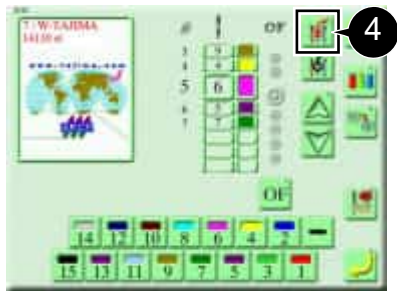

4 Press .
The needle bar step 4 is deleted.

1-5. Replacing the needle bar numbers at once

You can replace all the same needle bar No. in each needle bar step with another needle bar No. at once.

Replacing a needle bar No. also changes the color of the design image on the operation panel (OP).

The following example shows how to replace the instances of needle bar No. 8 in the needle bar steps with the needle bar No. 6 at once.

Before change			After change	
Needle bar step	Needle bar No.		Needle bar No.	
1	8	⇒	6	
2	5		5	
3	8	⇒	6	
4	5		5	
5	1		1	
6	8	⇒	6	



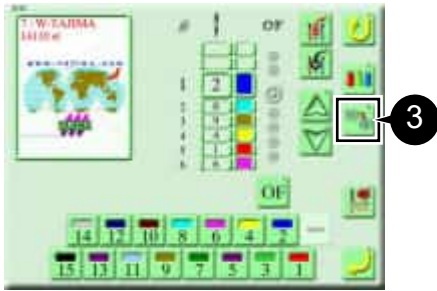

1 Select your desired design on the design selection screen.

2 Press .

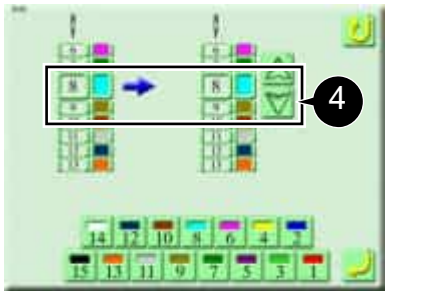

3 Press .



4 Press  and select the needle bar No. 8.

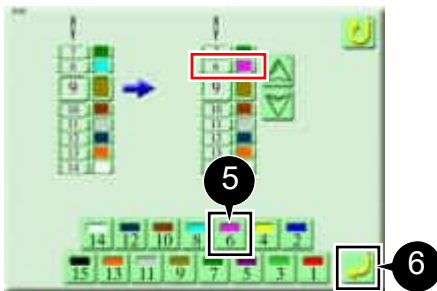

5 Press .

The needle bar No. 8 is changed to No. 6 (highlighted in red).

6 Press .

All of the specified needle bar No. are replaced at once.

1
2
3
4
5
6
7
8
9

2. Needle Bar Management Function

2-1. Setting the needle bar thread color

You can change the thread color assigned to each needle bar.

Changing the thread color also changes the color of the design image displayed on the operation panel (OP).

The following example shows how to change the needle bar numbers 1 and 5 to yellow and black, respectively.

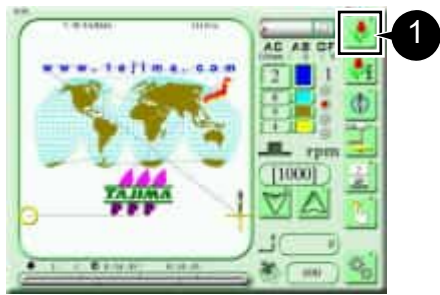

1 Press  on the main screen.



2 Select the design you want to change.

3 Press .

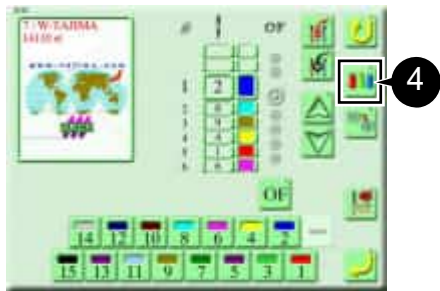

4 Press .



5 Press .

The needle bar No. 1 is selected.

6 Select yellow from the color palette.

The thread color of the needle bar changes to yellow.



7 Press .

The needle bar No. 5 is selected.

8 Select black from the color palette.

The thread color of the needle bar changes to black.



9 Press .

The specified thread colors are set.

1

2

3

4

5

6

7

8

9

3. Copying, Dividing and Combining Designs

3-1. Copying a design

Before you divide a design, you can copy the design in the machine memory so that the original design will be available. You can specify a folder in the “main” layer and each folder in the machine memory as the copying destination. You can copy as many designs as you like.

The following example shows how to select two designs and copy them into the “Group2” folder.

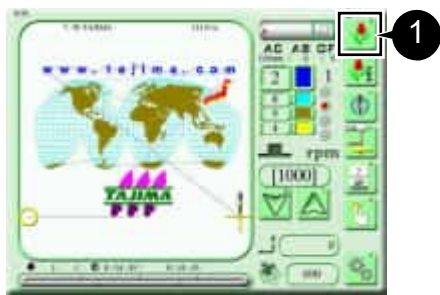

1 Press  on the main screen.

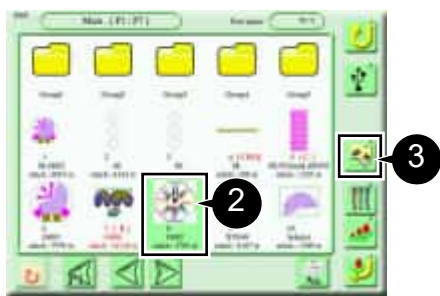

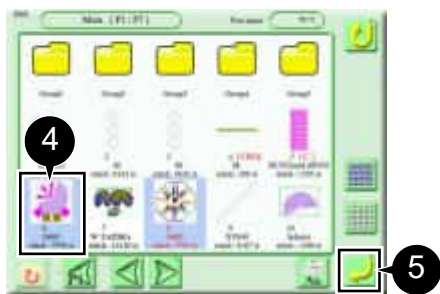

2 Select the 1st design you want to copy.

3 Press .



4 Select the 2nd design.



-  Select all designs
-  Deselect all designs

5 Press .

The design is selected.

6 Press .





7 Press  "Group2".

The designs are copied in the "Group2" folder.

3-2. Division of design

You can divide a design before and after your specified stitch No.. Note that the first divided design will include all the stitches prior to the specified stitch No.

The following example shows how to search for a design by Color Change function code and divide it before and after your specified stitch.



- This operation divides the original design. Copy the design in advance as needed.

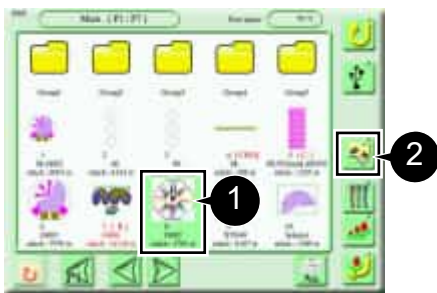

1 Select the design you want to divide on the design selection screen.

2 Press .

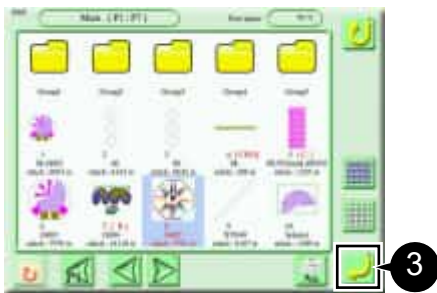

3 Press .

The design is selected.



4 Press .

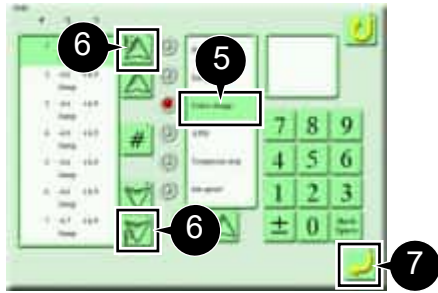

5 Select "Color change".

6 Start search.



: Stitches before the selected stitch will be searched.



: Stitches after the selected stitch will be searched.

Stitches that include the selected function code will be searched in order.



- For details on how to search stitches, refer to "Chapter 5 7-1. Search by stitch No.".

7 Press .

8 Press .

The design is divided.



- The following example shows how to divide the design No. 8 in the machine memory and save them in No. 8 and No. 155.

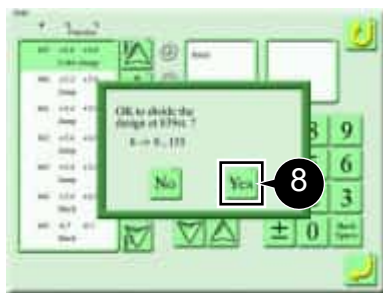

3-3. Combine of designs

You can combine multiple designs into a new design and save it in the same layer in the machine memory. The following example shows how to combine three designs.

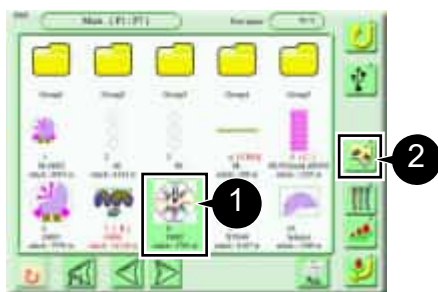

1 On the design selection screen, select the first design you want to combine.

2 Press .

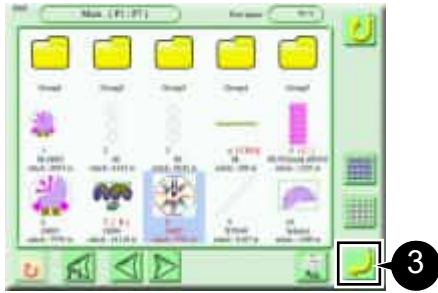

3 Press .

The 1st design is selected.



4 Press .



5 Press .





6 Select the 2nd design.

7 Press .

The 2nd design is selected.



- To change the 2nd or 3rd design, select the design and press . When the selected design is deleted, select another design using .
- To copy a design, select the design and press .
- If you want to combine two designs only, proceed to step 12.

1
2
3
4
5
6
7
8
9

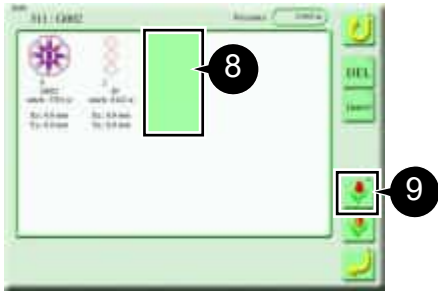

8 Press the side of the 2nd design.
A (green) space for a 3rd design is created.

9 Press .

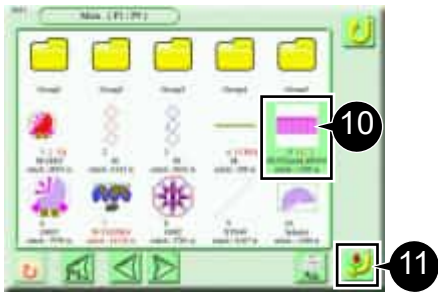

10 Select the 3rd design.

11 Press .

The 3rd design is selected.



12 Select the 1st design.

13 Press .

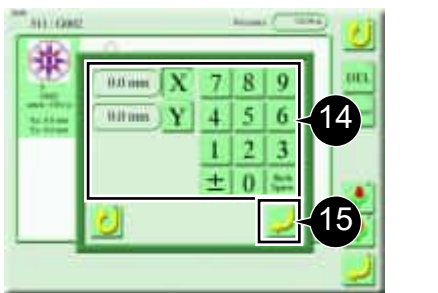

14 Enter the start position (X and Y coordinates) of the 1st design.



- You can use the frame travel key to enter the start position.

15 Press .

The start position is set.

16 Select the 2nd design.

17 Press .



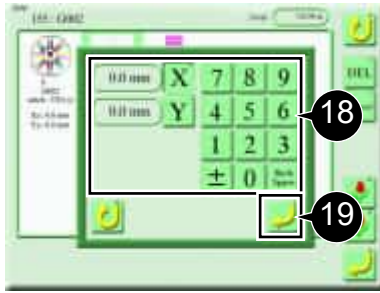

18 Enter the start position (X and Y coordinates) of the 2nd design.

19 Press .

The start position is set.



- If you want to combine two designs only, proceed to step 24.

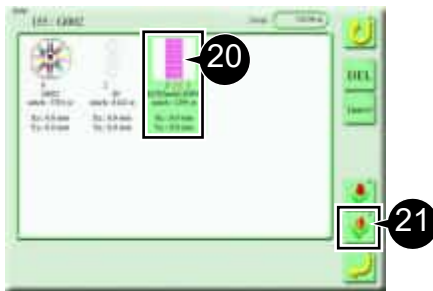

20 Select the 3rd design.

21 Press .

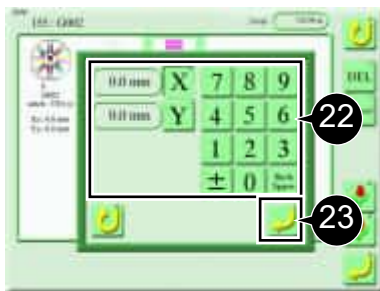

22 Enter the start position (X and Y coordinates) of the 3rd design.

23 Press .

The start position is set.

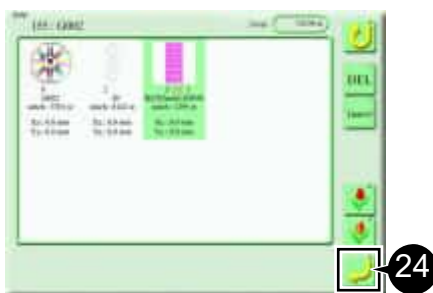

24 Press .

The designs are combined.



- After compositing, the design will be registered with the name you initially selected. If you want to change the design name, refer to "Chapter 4 3-1. Changing a design name.".

4. Design Conversion

You can change the design size and orientation or repeat the design.



- When you set rotation and reversion at the same time, the data will be rotated and then reversed.

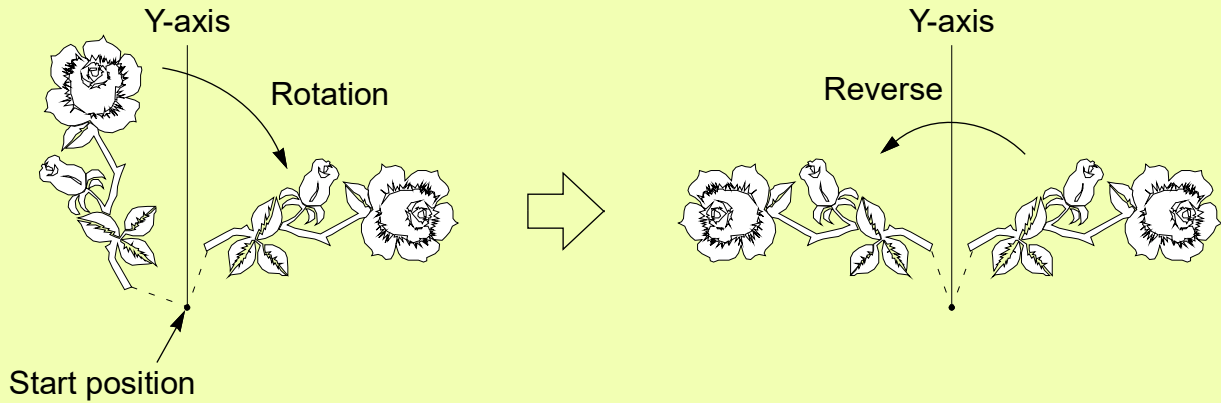

4-1. Scale up/down of design

You can enlarge/reduce your specified design. You can also enlarge/reduce a design at different ratio for the Y (vertical) and X (horizontal) axes.

Example: Y (vertical)/X (horizontal) enlargement at 150%

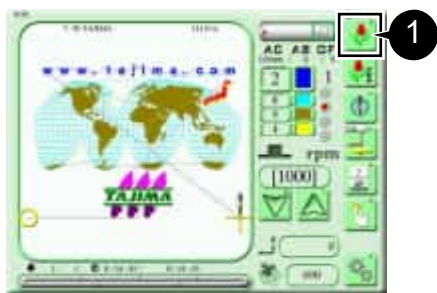
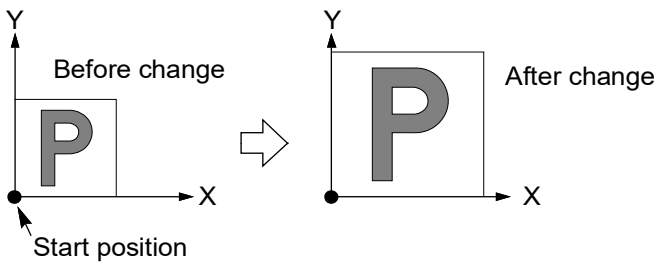

1 Press  on the main screen.



2 Select your desired design.

3 Press .



4 Press .





5 Enter the X (horizontal) ratio (for example, 150%).
The Y ratio field is filled in with the same value.



6 Press .

Your specified ratio value is set.



- To configure a Y (vertical) ratio different than the X (horizontal) ratio, press  and enter your desired Y (vertical) ratio. Then press .

4-2. Rotation of a design

You can rotate your specified design clockwise by 45° or 1°.

■ To rotate a design by 45°

Example: Rotation by 45°

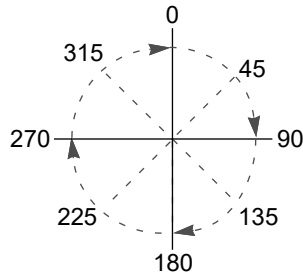
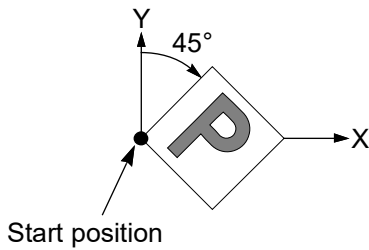

1 Select your desired design on the design selection screen.

2 Press .



3 Press the rotation angle (for example, for  45°).



4 Press .

Your specified rotation angle value is set.

■ To rotate a design by 1°

Example: Rotation by 5°

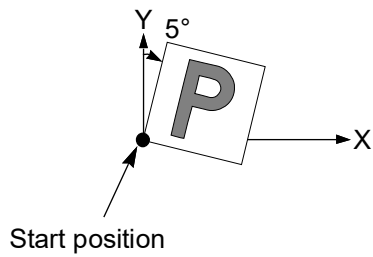

1 Select your desired design on the design selection screen.

2 Press .



3 Press .



4 Enter the rotation angle (for example, "5").

5 Press .

Your specified rotation angle value is set.

4-3. Reverse of design

You can reverse your specified design horizontally.

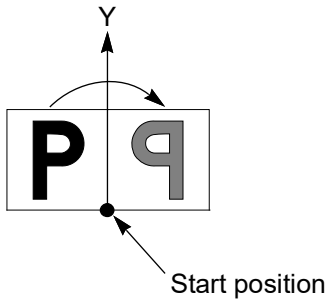

1 Select your desired design on the design selection screen.

2 Press .



3 Press .

The display changes every time you press the button.

 : Do not reverse

 : Reverse



4 Press .

The design is reversed.

5. Design Position Adjustment

You can adjust the position by rotating the design according to the inclination of the fabric.



- You cannot set this function during embroidery.
- When performing the data set of the other design after setting this function, the setting contents will be canceled. Also, the setting contents are not saved in the design.
- This function can not be set for the designs that "Repeat" or "Auto Offset" is set. It is not possible to set "Repeat" or "Auto Offset" later for the design that this function has been set.
- This function can be set for the designs that "Data conversion" is set. However, "Data conversion" can not be set for the design that this function has already been set.

5-1. Outline of function

■ Rotation

After determining P1 and P2 with the frame travel key, you can rotate the design based on the design start point by the angle (A) formed by the diagonal line between P1 and P2.

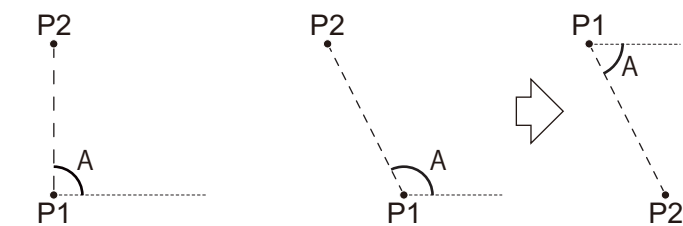
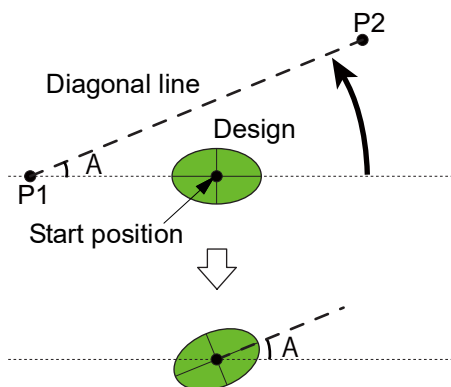

If the angle exceeds 90 degrees, P1 and P2 will be interchanged after moving the frame manually.

Setting range $0^\circ \leq A < \pm 90^\circ$

If the angle (A) is close to 90° , set it in rotation (vertical).

■ Design placement

After determining P1 with the frame travel key, you can place the design based on P1.

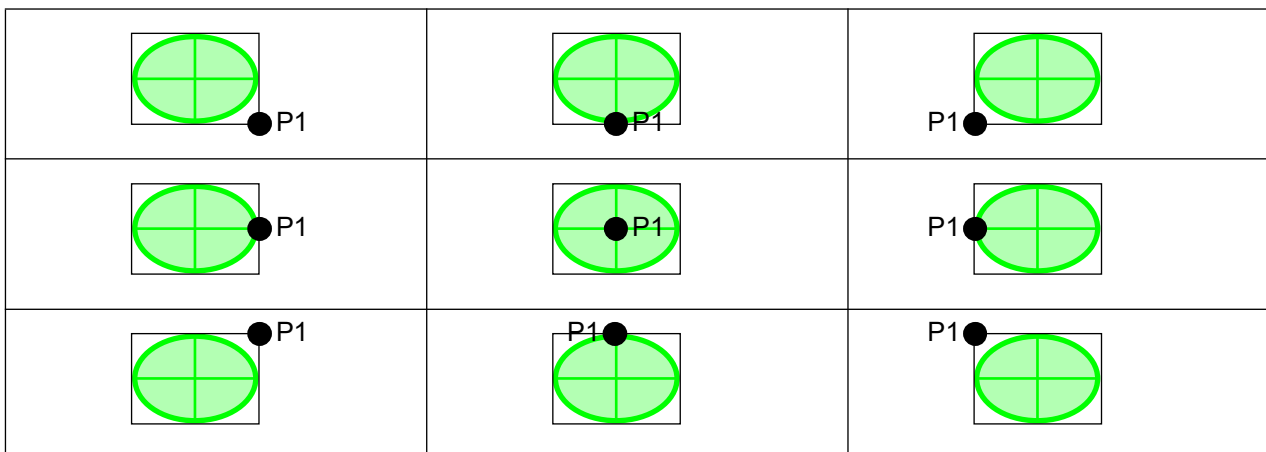

- Design placement is different from design start position. If you want the design position and the design start position to be at the same position, use the frame start position (9P) in the parameter setting to align them.

■ Rotation and Design placement

After determining P1 and P2 with the frame travel key, you can rotate the design based on the design start point by the angle formed by the diagonal line between P1 and P2 and place the design to a specified position.

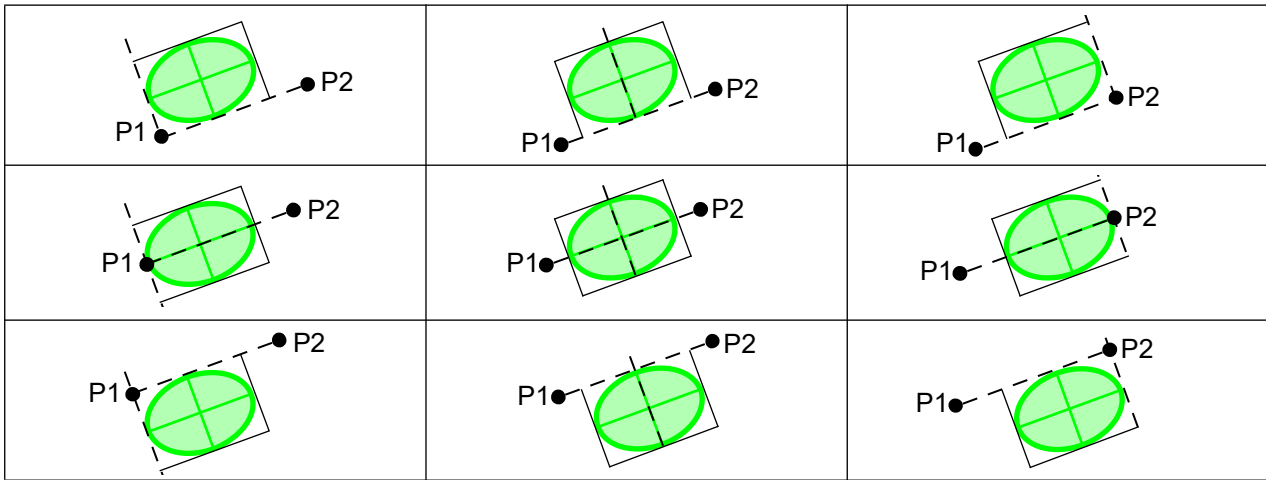

5-2. How to adjust

■ Change to the adjustment screen



1 Press  on the main screen.



2 Press .



3 Select the desired adjustment method.

 : Rotation

 : Design placement

 : Rotation and Design placement

 : Rotation (vertical)

■ For rotation

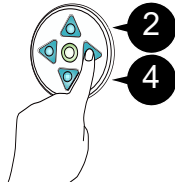
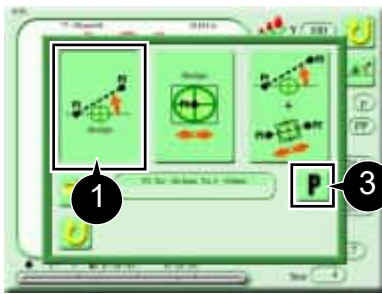

1 Press .

2 Move the frame to the position to be P1.

3 Press .

The position of the P1 is set.



- To set the current frame position to P1, just press



4 Move the frame to the position to be P2.



- P1 and P2 will be interchanged if the coordinate of P2 becomes lower than that of P1 (i.e., moving the frame to the right).

5 Press .

The position of the P2 is set.

6 Press .

The design rotates according to the set reference line (the line connecting P1 and P2).

7 Execute the trace.



: High speed



: Low speed



- If trace error No. 225 is displayed, correct the position of the frame with the frame travel key and perform tracing again. The corrected position is the start position.

• If tracing is not required, press .

■ For rotation(vertical)

When adjusting based on the vertical direction of the fabric



1 Press .

The screen switches.





2 Press .

3 Move the frame to the position to be P1.

4 Press .

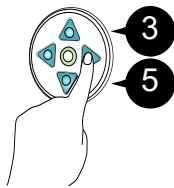
The position of the P1 is set.



- To set the current frame position to P1, just press .

5 Move the frame to the position to be P2.



- P1 and P2 will be interchanged if the coordinate of P2 becomes lower than that of P1 (i.e., moving the frame to the right).



6 Press .

The position of the P2 is set.



7 Press .

The design rotates in accordance with the set reference line (the line connecting P1 and P2).

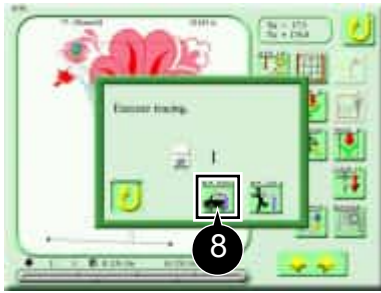

8 Execute the trace.



- If trace error No. 225 is displayed, correct the position of the frame with the frame travel key and perform tracing again. The corrected position is the start position.

- If tracing is not required, press .

■ For design placement

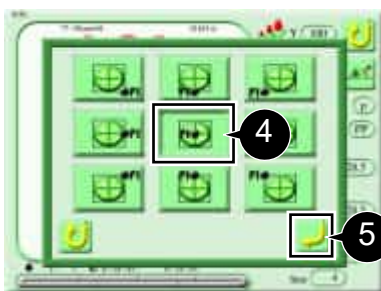
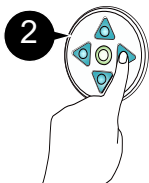
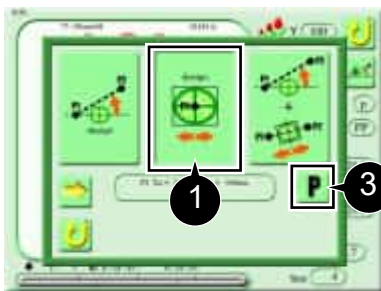

1 Press .

2 Move the frame to the position to be P1.

3 Press .

The position of the P1 is set.

4 Select the desired placement pattern.

Example) Press .

5 Press .

The design is placed in the position based on P1 that has been set.

1
2
3
4
5
6
7
8
9

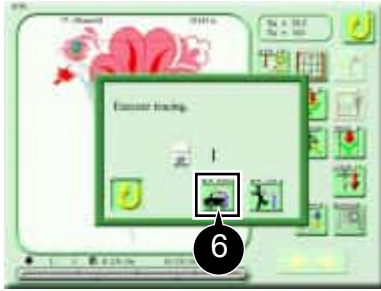

6 Execute the trace.



- If trace error No. 225 is displayed, correct the position of the frame with the frame travel key and perform tracing again. The corrected position is the start position.
- If tracing is not required, press .

■ For rotation and placement

Select the desired placement pattern after performing the same operation as rotation.



When the design position adjustment is completed, An icon for each adjustment will be displayed on the main screen.



- After adjusting rotation or rotation and placement, A reference line will be displayed on the main screen (i.e., the line connecting P1 and P2).

6. Setting for Repeat

You can repeat your specified design.

If the design is enlarged/reduced or rotated/reversed, the changed shape is repeatedly placed.

6-1. Repeating a design by specifying the number of repetitions

You can repeat a design by specifying the number of repetitions and the vertical and horizontal distances.

Example:

- Repeat 3 times horizontally at distances of 50 mm
- Repeat 2 times vertically at distances of 60 mm
- Priority direction: Horizontal

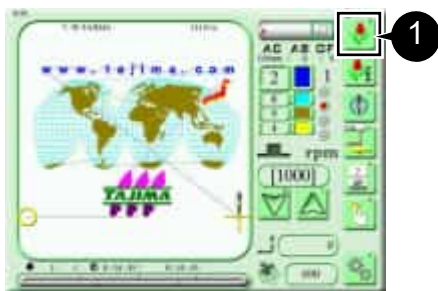
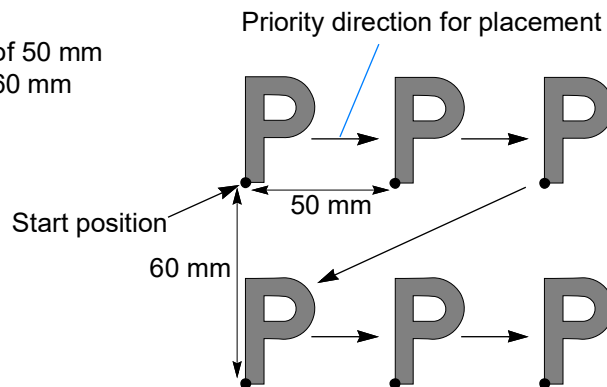

1 Press  on the main screen.



2 Select your desired design.

3 Press .

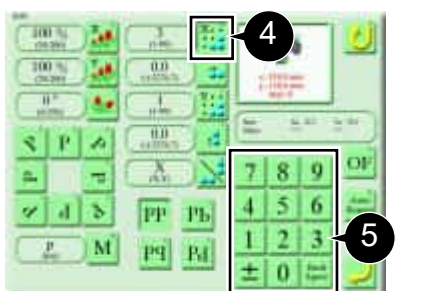

4 Press .



5 Enter the horizontal number of repetitions (for example, "3").



6 Press .

7 Enter the horizontal distance (for example, "+50.0").



- To repeat on the right side, press  to select [+].
- To repeat on the left side, press  to select [-].

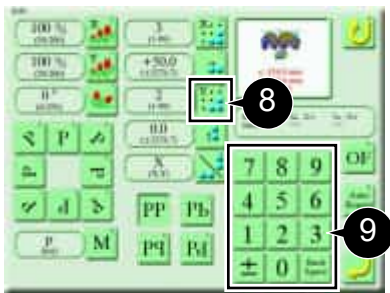

8 Press .



9 Enter the vertical number of repetitions (for example, "2").



10 Press .

11 Enter the vertical distance (for example, "-60.0").



- To repeat on the upper side, press  to select [+].
- To repeat on the lower side, press  to select [-].



12 Press .

Your specified number of repetitions is set.



- If you add a setting to a data set design, the data set will be canceled.
- If you set a data which has repetition setting, the number of repetitions and the required embroidery time will be displayed in the red frame.

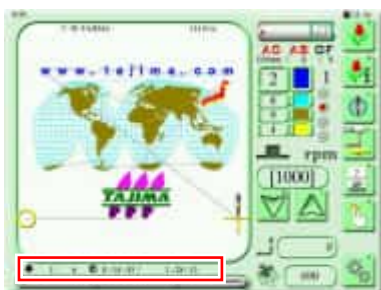

6-2. Repeating a design by automatically calculating the number of repetitions

You can repeat a design by specifying the distance and automatically calculating the number of designs that can be placed in the embroidery space.

Example:

- Horizontal distance: 50 mm
- Vertical distance: 60 mm
- Placement position: Center

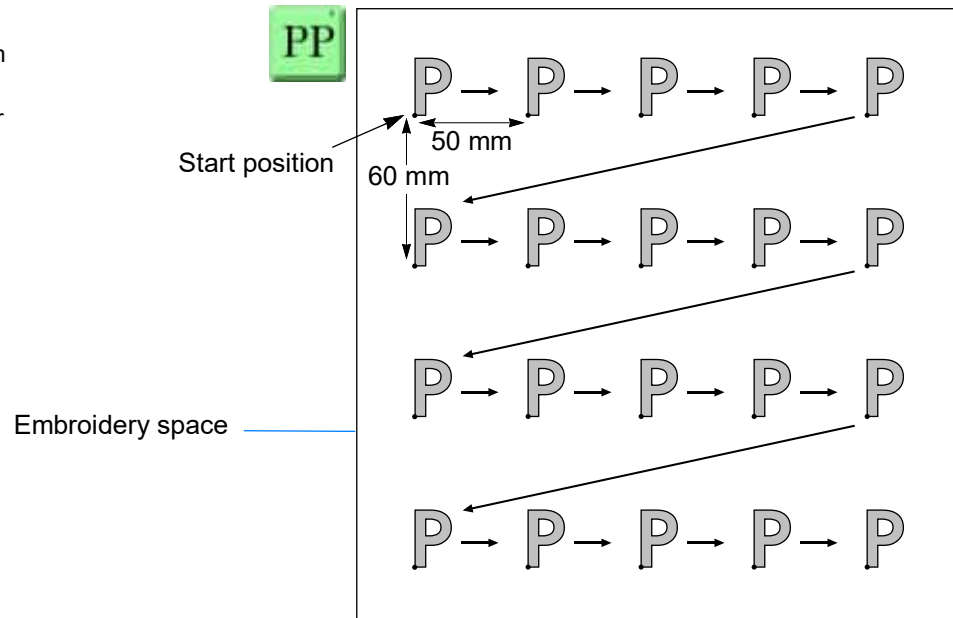

1 Select your desired design on the design selection screen.

2 Press .



3 Press .



4 Enter the horizontal distance (for example, "50.0").

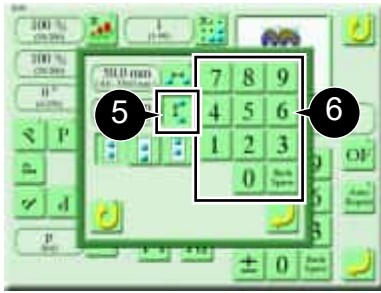

5 Press .

6 Enter the vertical distance (for example, "60.0").

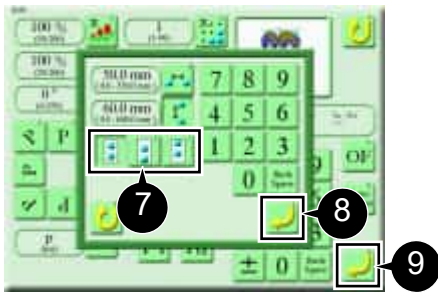

7 Select the placement method.



: Place in the center



: Place from the front side



: Place from the rear side

8 Press .

The number of repetitions is automatically calculated.

9 Press .

Auto repeat is set.

6-3. Reversing or rotating a design alternately

You can place the design by reversing or rotating alternately at the odd numbered times and the even numbered times.

Reverse based on X-axis

Example: **Pb** (Vertical priority)

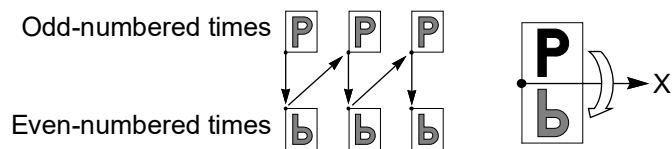

Reverse based on Y-axis

Example: **Pq** (Vertical priority)

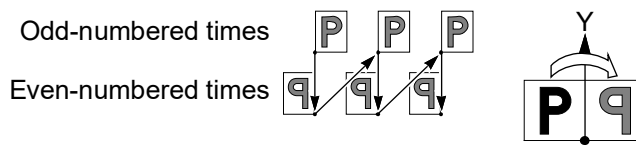

180° rotation

Example: **Pd** (Vertical priority)

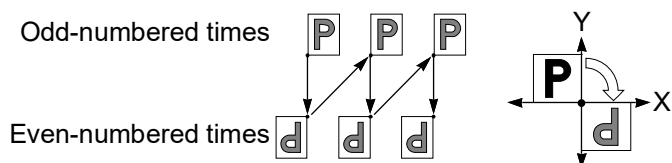

1 Select your desired design on the design selection screen.

2 Press .



3 Configure the X (horizontal) and Y (vertical) numbers of repetitions, distances, and directions.



4 Select the method of placement (whether to reverse or rotate them).

Pb : Reverse based on X-axis

Pq : Reverse based on Y-axis

Pd : Rotate 180°

5 Press .

The placement method is set.

7. Editing Stitches

You can search for stitch data (hereinafter “stitches”) of designs saved in the machine memory.

7-1. Search by stitch No.

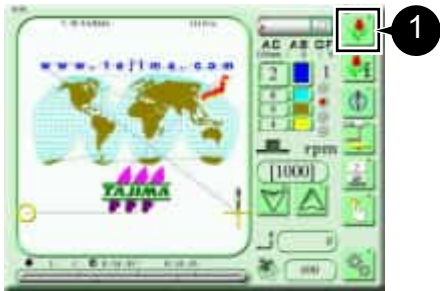

1 Press  on the main screen.

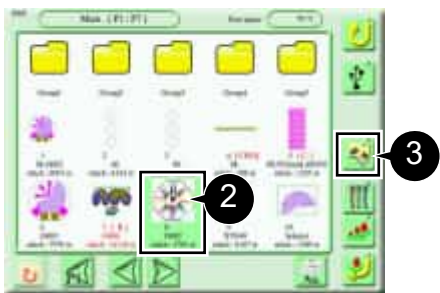

2 Select your desired design.

3 Press .

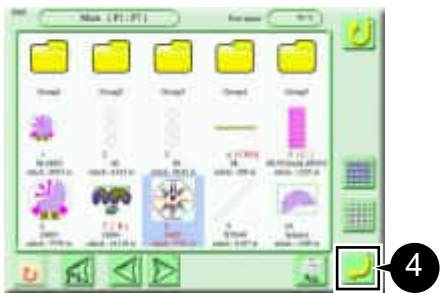

4 Press .
The design is selected.



5 Press .

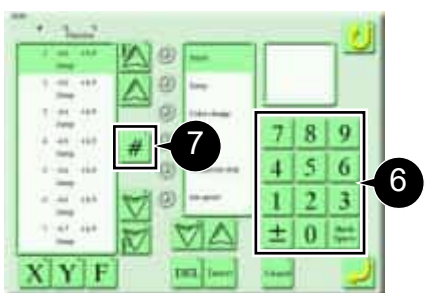

6 Enter your desired stitch No. (for example, “480”).

7 Press .
The entered stitch No. is displayed.

7-2. Search by function code

You can select more than one function code to search for stitch data.

For more information on the function codes, operations, and details, see the table below.

Function Code	Movement	Detail
Stitch	Stitches will be sewn.	
Jump	Jumping will be performed. (Frame travel without needle locating)	
Color Change	Stop by color change will be performed.	
ATH	Upper thread or upper/under threads will be trimmed automatically.	Upper thread ^{*1} , upper/under threads
Temporary stop	Temporary stop will be performed at stitch or jump.	Stitch, jump
Low speed	A low speed operation will be performed at specified stitch section.	Start S, end S Start J, end J
Satin Stitch	Satin stitch conversion will be performed at specified section.	Start, end
Automatic free-setting offset	Frame travel will be performed according to the setting of automatic offset.	
Sequin	Sequin device will work at specified block.	Start, end, Output 1, output 2
ATH prohibited	ATH will not be performed at specified stitch section.	Start S, end S Start J, end J
Seed beads	Seed beads device will work at specified section.	Start, end, Output 1, output 2

*1: The machine trims upper/under threads even if "Upper thread" is selected.

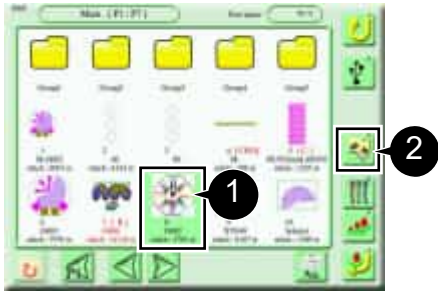

1 Select your desired design on the design selection screen.

2 Press .

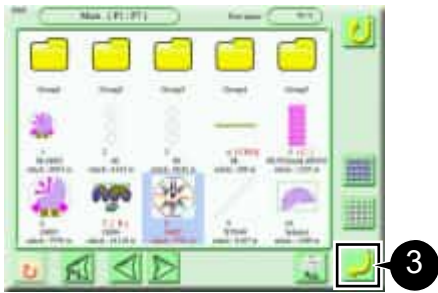

3 Press .
The design is selected.



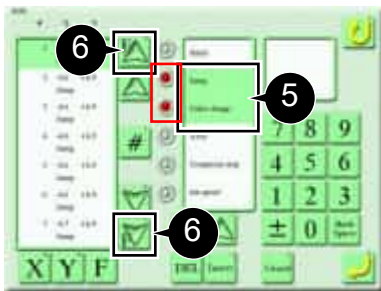

4 Press .



5 Select a function code (for example, “Jump”, “Color change”).
The radio buttons at left are lit in red.

6 Start search.

 : Stitches before the selected stitch will be searched.

 : Stitches after the selected stitch will be searched.

Stitches that include the selected function code will be searched in order.

7-3. Modification of stitch

You can change the function code of your specified stitch.



- This operation overwrites the original design. Copy the design in advance as needed.
- If an embroidery stitch after change differs in length from the embroidery stitch before change, all the subsequent stitches in the design will be displaced.



- To change stitches, enter the password to set the functional limit level to "SEL".

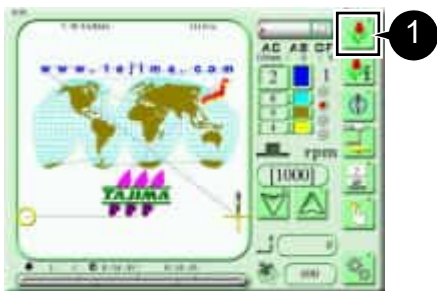

1 Press  on the main screen.

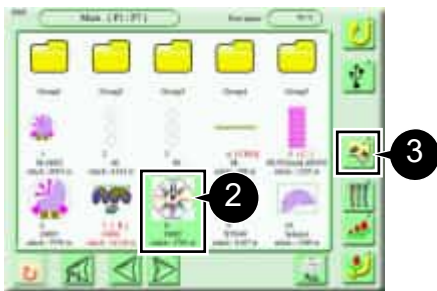

2 Select your desired design.

3 Press .

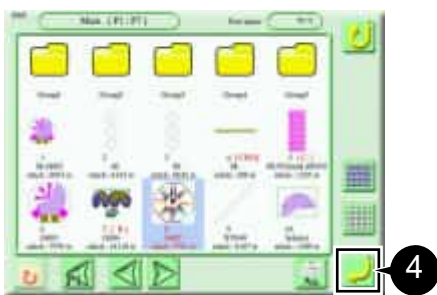

4 Press .

The design is selected.



5 Press .

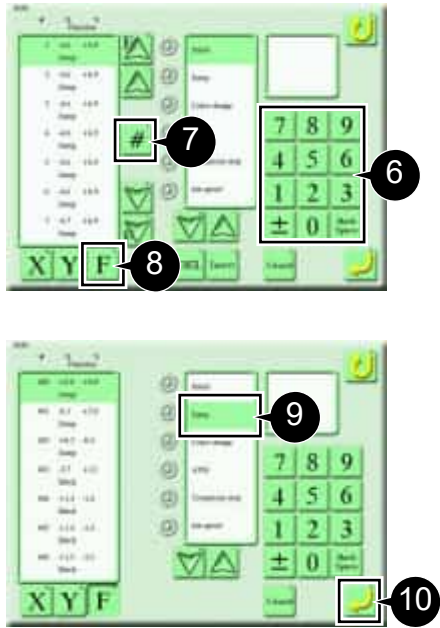

6 Enter the stitch No. (for example, “480”) for which you want to change a function code.

7 Press .

8 Press .

9 Select a function code (for example, “Jump”).

10 Press .

The function code is changed.

7-4. Insertion of stitch

You can insert a new stitch before the selected stitch.



- This operation overwrites the original design. Copy the design in advance as needed.
- Inserting a stitch with a length displaces all the subsequent stitches in the design.



- To insert a stitch, enter the password to set the functional limit level to “SEL”.

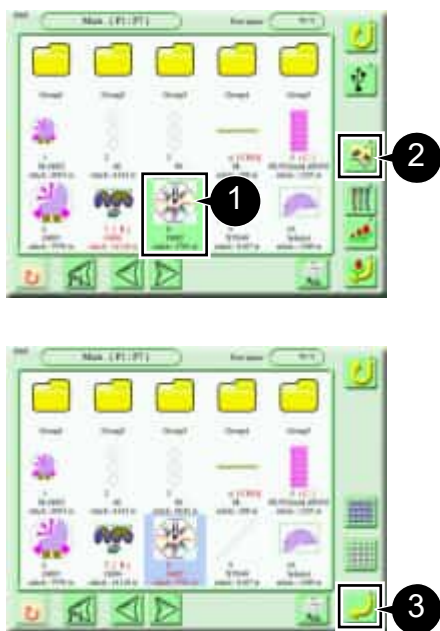

1 Select your desired design on the design selection screen.

2 Press .

3 Press .

The design is selected.



4 Press .

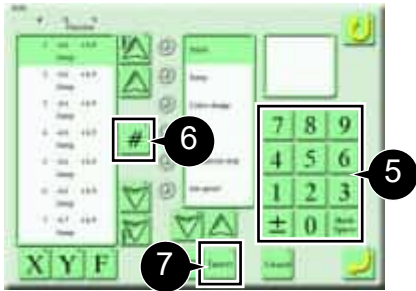

5 Enter the stitch No. for the new stitch you want to insert (for example, "480").

6 Press .

7 Press .

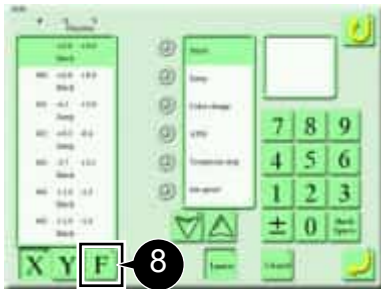

8 Press .

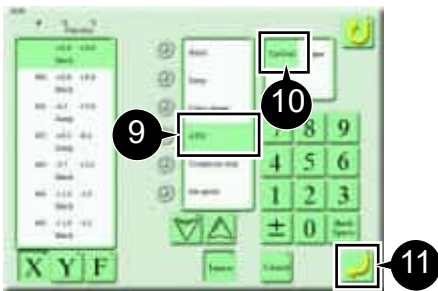

9 Select a function code (for example, "ATH").

10 Select a thread trimming method (for example, "Up/Und").

11 Press .

A new stitch is inserted.

1

2

3

4

5

6

7

8

9

7-5. Deletion of stitch

You can delete your specified stitch.



- This operation overwrites the original design. Copy the design in advance as needed.
- Deleting a stitch with a length displaces all the subsequent stitches in the design.



- To delete a stitch, enter the password to set the functional limit level to “SEL”.

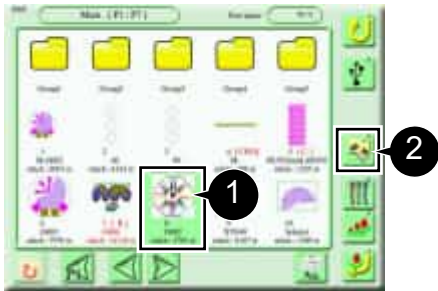

1 Select your desired design on the design selection screen.

2 Press .

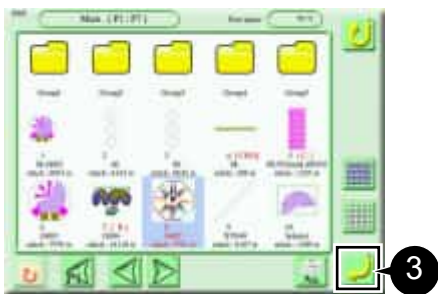

3 Press .

The design is selected.

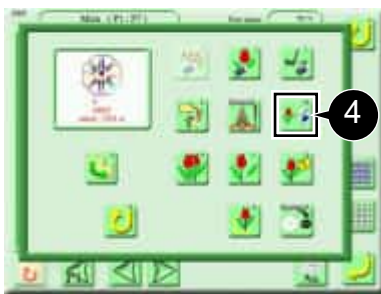

4 Press .

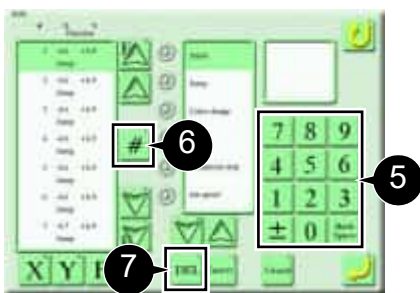

5 Enter the stitch No. for the stitch you want to delete (for example, “480”).

6 Press .

7 Press .

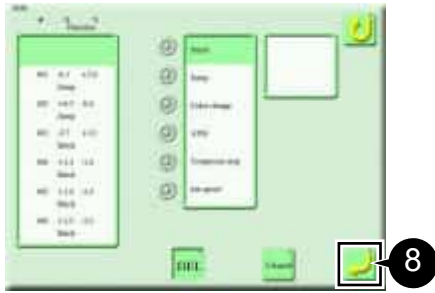

8 Press .

Your specified stitch is deleted.

7-6. Removal of tiny stitches

You can remove tiny stitches by merging them into the previous and next stitches.

This feature can reduce thread casts-off and thread breakages.

As long as designs are saved in the same layer, you can use this feature without depending on the number of designs.

The following example shows how to remove 0.5 mm and smaller stitches by selecting two designs.



- This operation overwrites the original design. Copy the design in advance as needed.
- Design shape may be changed once clean-up is executed.

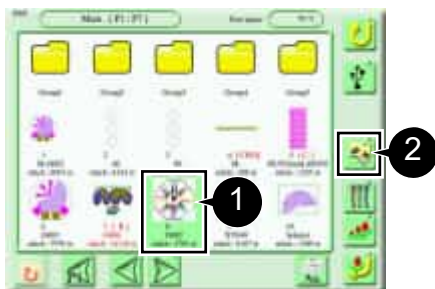

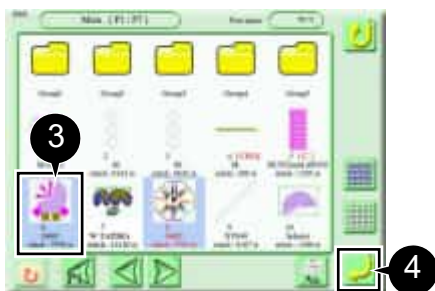

1 Select your desired design (the 1st design) on the design selection screen.

2 Press .



3 Select the 2nd design.



-  Select all designs
-  Deselect all designs

4 Press .

The design is selected.



5 Press  .

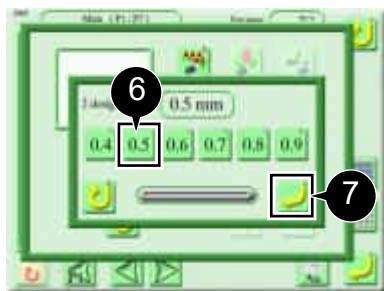

6 Press  .



- If you select one design and press  , the number of stitches to be removed is displayed.



7 Press  .

8 Press  .

0.5 mm and smaller stitches are removed.

Chapter 6

Various functions

1. Automatic Frame Travel (Automatic Offset)

1-1. Outline of function

To make it easy to replace the frame or fabric, set an applique fabric, and check the embroidery finish, you can automatically move the frame to an arbitrary position (where work is easy) after or during embroidery. To use this feature, register the position where to move the frame (hereinafter the "offset position") in advance. Select any of the following three types of offset frame travel according to the timing of use.

■ Automatic Offset

Move the frame to the offset position upon completion of embroidery.

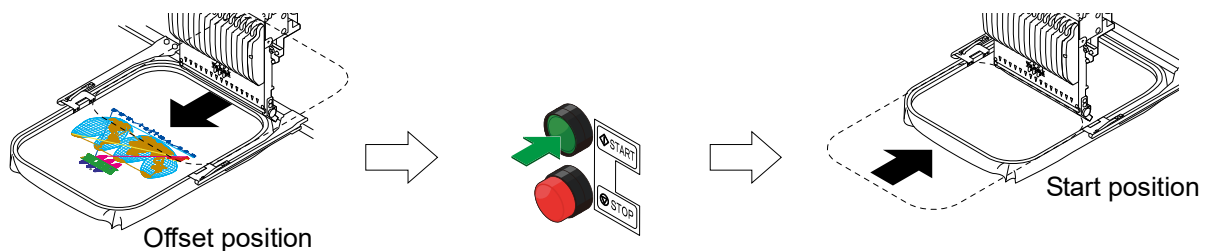

The frame moves to the offset position upon completion of embroidery.

Once you replace the fabric and start the machine, the frame automatically moves to the start position and embroidery starts.

[If you have registered the offset middle position]

The frame moves via the offset middle position to the offset position upon completion of embroidery.

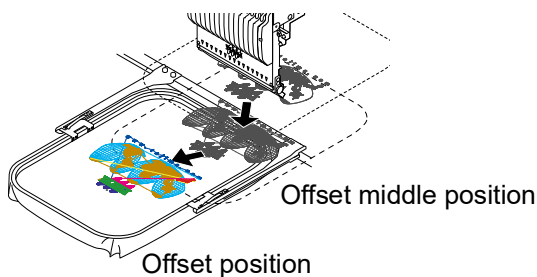

- Registering the offset middle position also allows you to move the frame to avoid the head while performing placing embroidery.
- You can register two offset middle positions.

■ Automatic free-setting offset

You can stop the machine at your specified stitch position and move the frame to the offset position. Moving the frame to the front side makes it easy to set an applique fabric, for example.

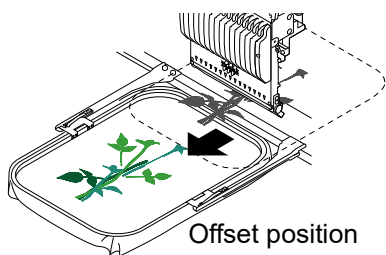

The frame automatically moves to the offset position during embroidery.

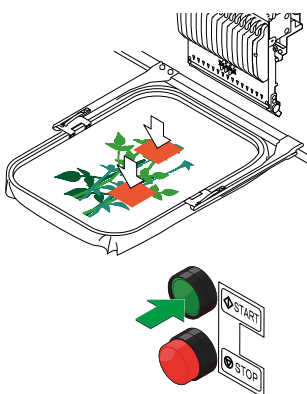

Place an applique fabric.

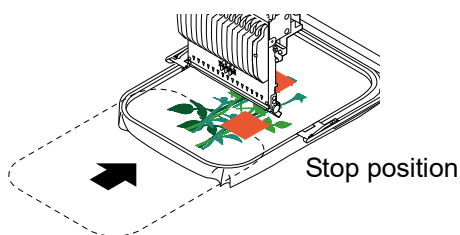

Once you start the machine, the frame automatically returns to the stop position and embroidery is resumed.

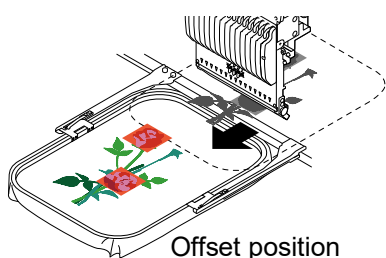

The frame automatically moves to the offset position upon completion of embroidery.



- Register the offset position in advance.
- The frame moves to the offset position during and after embroidery.

■ Automatic color change offset

You can stop the machine at the color change position and move the frame to the offset position. Moving the frame to the front side makes it easy to set an applique fabric, for example. The frame moves in the same manner as that for an automatic free-setting offset.

1-2. Registration of the Offset Position

You have to register an offset position on a design by design basis.

The following example shows how to register the start position, the offset middle position (OF1), and the offset position (OF2).

⚠ CAUTION



Do not put your hands on the table when you operate the machine. Failure to observe this may result in injury due to the frame travel.



- The offset position is registered for each design. You do not need to register it again the next time you embroider the design.

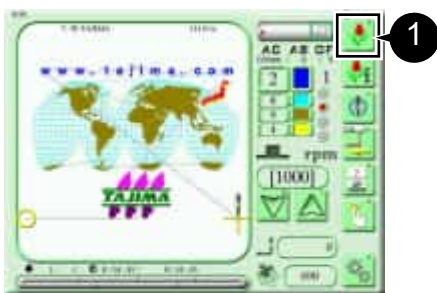

1 Press  on the main screen.



2 Select your desired design.

3 Press .



4 Press .

The offset settings screen appears.

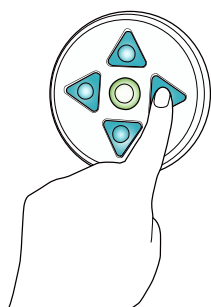

• Start position

5 Using the frame travel key, move the frame to the start position.

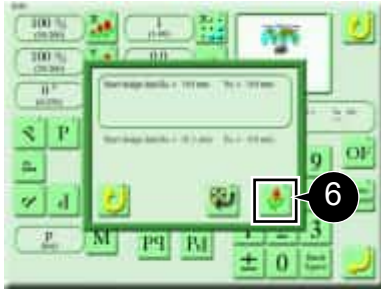

6 Press .

The current frame position is set as the start position.



- You can move the frame to the start position of the design by pressing  when the current position is set as the start position.

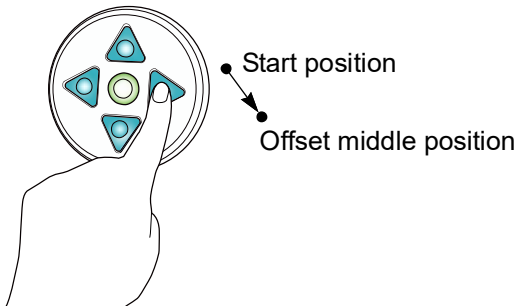

7 Using the frame travel key, move the frame to the offset middle position.



- If you do not want to register the offset middle position, proceed to step 8.

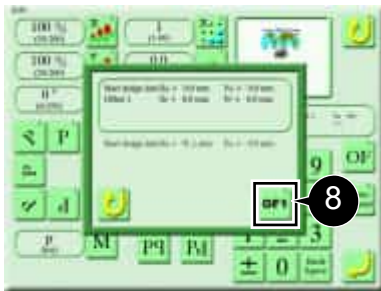

8 Press .

The current frame position is set as the offset middle position.

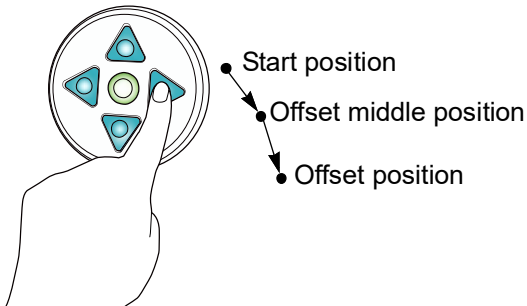

9 Using the frame travel key, move the frame to the offset position.

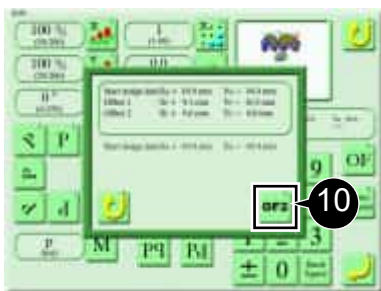

10 Press .

The current frame position is set as the offset position.



11 Press .

Each position is registered.

1-3. Erasing the offset position

CAUTION

 Do not put your hands on the table when you operate the machine. Failure to observe this may result in injury due to the frame travel.



1 Select your desired design on the design selection screen.

2 Press .



3 Press .



4 Press .

1. Automatic Frame Travel (Automatic Offset)

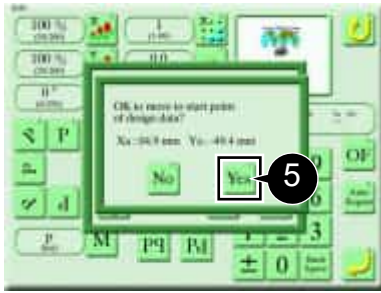

5 Press .

The frame moves to the start position.

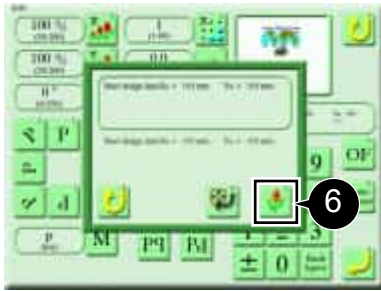

6 Press .

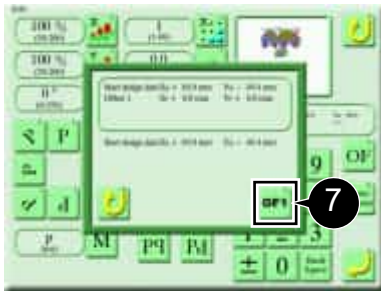

7 Press .



8 Press .

The offset position is erased.

1-4. Moving the frame by specifying an arbitrary stitch

The following example shows how to insert an automatic free-setting offset code at the 480th stitch.



- To use this feature, enter the password to set the functional limit level to "SEL".
- Register the offset position in advance.



1 Select your desired design on the design selection screen.

2 Press .



3 Press .
The design is selected.



4 Press .

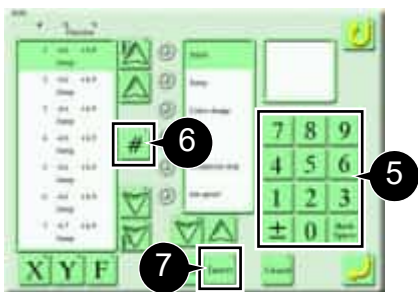

5 Enter "480".

6 Press .

7 Press .

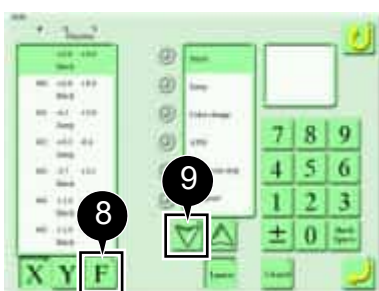

8 Press .

9 Press .

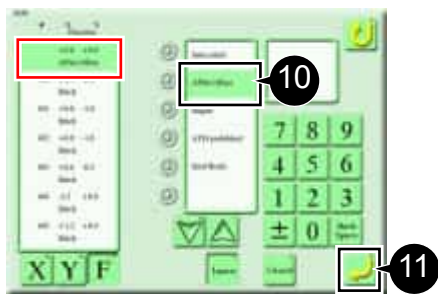

10 Select "AFSet Offset".
An automatic free-setting offset code (in the red box) appears at the 480th stitch.

11 Press .
An automatic free-setting offset code is inserted.

1-5. Moving the frame at the color change position

The following example shows how to add an offset (OF) between the needle bar steps 4 and 5.





- Register the offset position in advance.



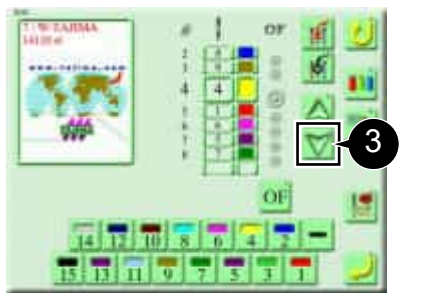

1 Select your desired design on the design selection screen.

2 Press .

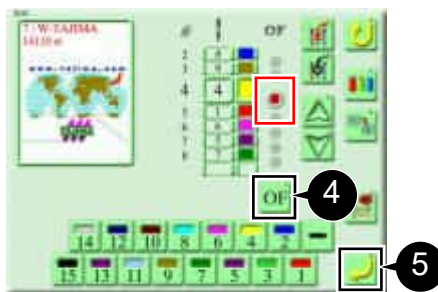

3 Press  to select the needle bar step 4.



4 Press .
An automatic color change offset (OF) is lit in red.

5 Press .
An automatic color change offset is added.







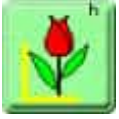

2. Marking

2-1. Outline of function

Before you perform applique embroidery or placing embroidery, you can create basting data (marking design) to help to correctly place the material.

There are two types of marking designs: "Point" and "Contour". "Points" are used to manually create marking designs. "Contours" are used to automatically mark the contours of designs.

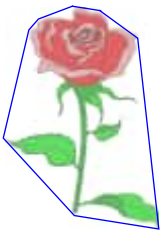
Markings are available in the following combinations. Use the combinations to best suite your purpose.

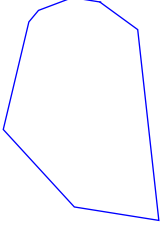
Marking Design	With or without design	Embroidery image	Description
Point 	With design 		Register the point and design in the machine memory.* ¹
	Without design 		Register only the point in the machine memory.
Contour 	With design 		Register the contour and design in the machine memory.* ¹
	Without design 		Register only the contour in the machine memory.

*¹ If combined with a design, an automatic free-setting offset code is automatically appended to the end of the marking design. If you register an offset position, the frame automatically moves to the offset position after the embroidery of the marking design.

For details, refer to "Chapter 6 1. Automatic Frame Travel (Automatic Offset)".

2-2. Creating a marking design

The following example shows how to set the marking type to “Point”, create a marking “with a design”, and set the stitch length to “5.0 mm”.





- Once you create a marking design, it is automatically registered as “M-” in a free number on the design selection screen.
- If you set the marking type to “Contour”, skip steps 10 to 15 and proceed to step 16 because the marking is automatically created.

CAUTION

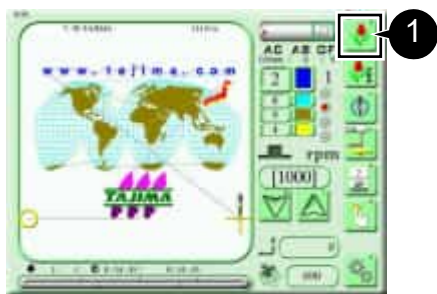

Do not put your hands on the table when you operate the machine. Failure to observe this may result in injury due to the frame travel.



1 Press  on the main screen.



2 Select your desired design.

3 Press .



4 Press .



5 Press .

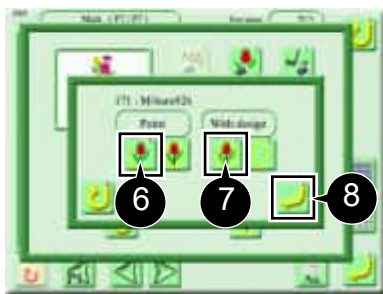

6 Press 

7 Press 

8 Press 

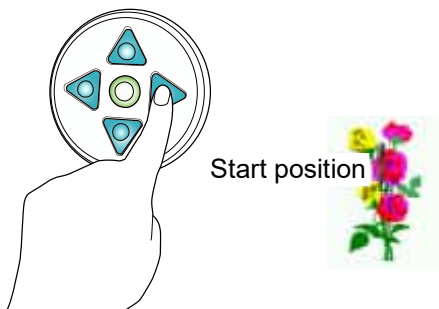

9 Using the frame travel key, move the frame to the start position of the design.



- You can specify up to 10 marking points.
- You can also move the frame to the start position of the design by pressing  and

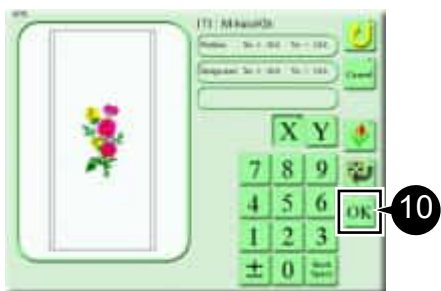

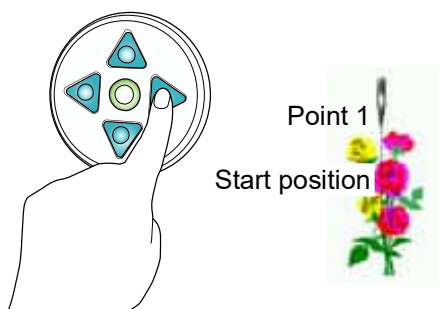

10 Press 

The start position of the design is set.



11 Move the frame to the point 1 by pressing the frame travel key.



- Enter the coordinates of the point 1 (based on the start position) using numeric keys and press 
- and  to move the frame.

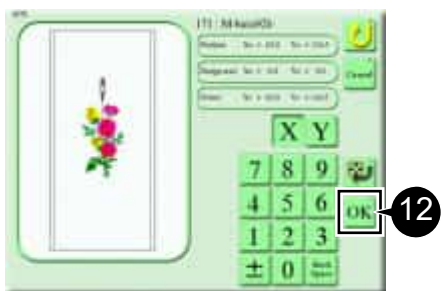

12 Press 

Point 1 is registered.

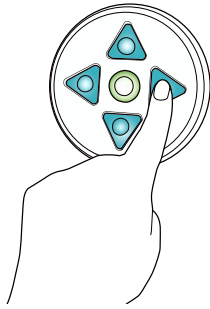

Point 2

13 Move the frame to the point 2 by pressing the frame travel key.



- Enter the coordinates of the point 2 (based on the point 1) using numeric keys and press **OK** and



to move the frame.

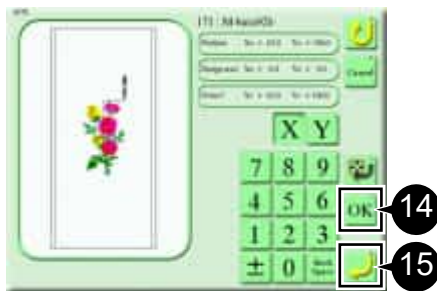

14 Press **OK**.

Point 2 is registered.



- Once you register two or more points, a new marking design is automatically registered.

15 Press .

The points have been set. Numerical keys for setting the stitch length is displayed.

16 Enter "50".

17 Press .

The marking design is registered.

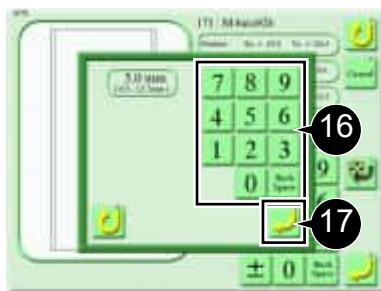

Chapter 7

Maintenance

1. Precautions for Maintenance

WARNING

- ❗ Be sufficiently trained and instructed on how to perform maintenance work such as lubrication and adjustment before actually doing so.
- ❗ Greasing, inspection of drive systems, and repair of the machine must be performed by the distributor or the service personnel assigned and trained by TAJIMA. Failure to observe this may result in injury, electric shock, or other serious accident.
- ❗ Ensure the safety by turning OFF the machine power and removing the power plug from the outlet before starting maintenance work.
- ❗ Keep the power cord unplugged and close at hand when performing repair work to prevent unexpected startup. Also, provide a sign indicating that work is in progress.
- ❗ Upon completion of maintenance work, re-install all the covers you removed. Running the machine with covers removed may result in being caught in the moving parts.

CAUTION

- ❗ Perform maintenance work periodically. Lack of maintenance may result in early deterioration or failure of parts. Damage arising from lack of maintenance may be excluded from the scope of guarantee.
- ❗ If the machine is not used for a long period, turn ON the power switch (PSW) in regular intervals. Although each card of the machine has a backup battery, data may be lost in about one month because voltage of the battery will come down gradually due to discharge when the power switch (PSW) is turned OFF.
- ❗ When you work underneath the machine table, ensure sufficient lighting.

2. Maintenance Item List

Daily maintenance and inspection are important to prevent machine trouble.
Use the following maintenance and inspection items for maintenance plans, etc.

■ Maintenance and inspection items

Frequency	Parts	Maintenance and inspection content
Once per 5 to 6 hours	Rotary hook	Lubrication
Every day	Inside of the cylinder bed	Cleaning
Once/week	Head and its surroundings	Cleaning
	Inside of head	Lubrication
	Drive system	Cleaning
	Presser foot shaft	Cleaning
Once every three months	Inside of head	Greasing
Once every six months	Cylinder bed gear	Greasing

3. Cleaning

Clean accumulated lint and dust, using a commercially available cleaning tool, an air gun, and the supplied brush.

3-1. Inside of the cylinder bed

Frequency: Every day

■ Cleaning of the interior

In ATH cleaning mode, the inside of the cylinder bed is cleaned with a brush or air gun while the movable knife is open.



- See "Chapter 3 5-1. ATH cleaning mode".

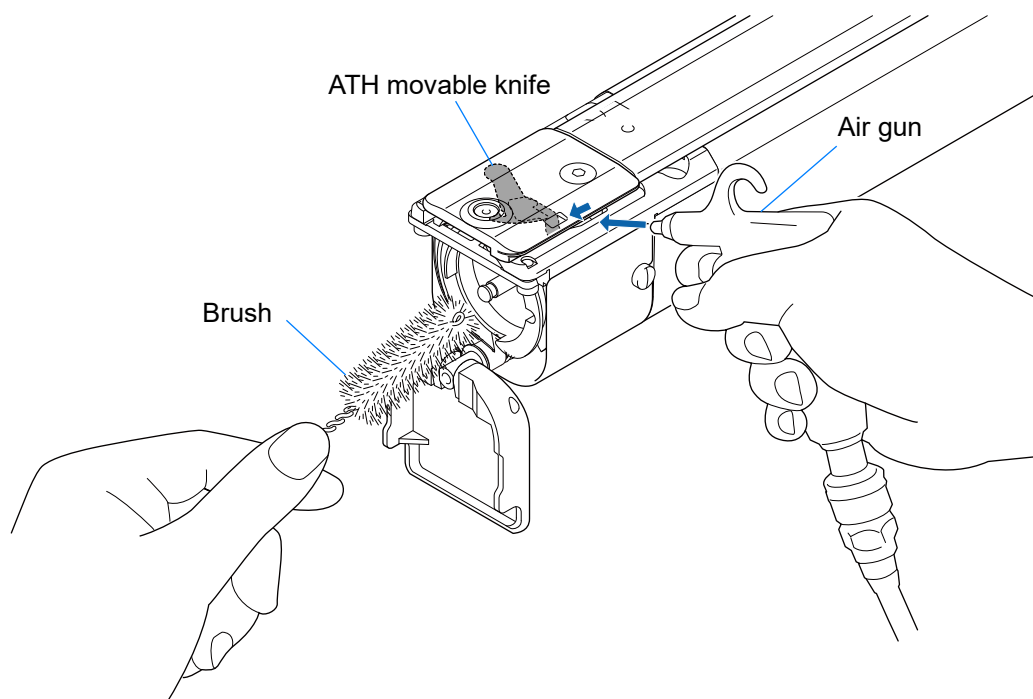

3-2. Head and its surroundings

Frequency: Once a week

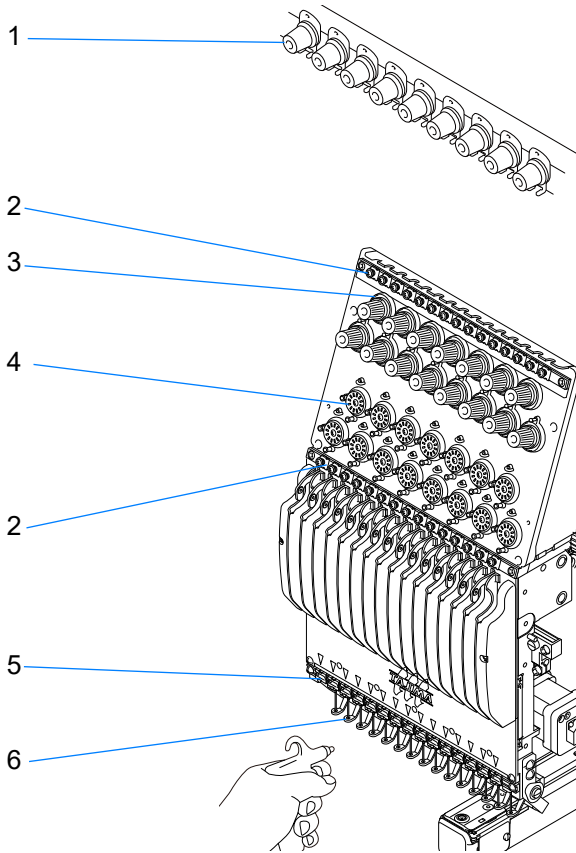

	Cleaning area
1	First thread tension regulator
2	Thread presser
3	Second thread tension regulator
4	Rotary tension disk
5	Upper thread lock
6	Presser foot
7	Presser foot shaft

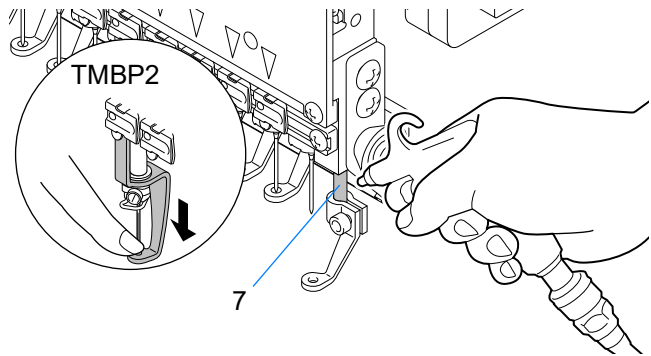

3-3. X-axis drive system, Y-axis drive system

Frequency: Once a week

Using the air gun, air-blow the interior from the slits of the drive system.

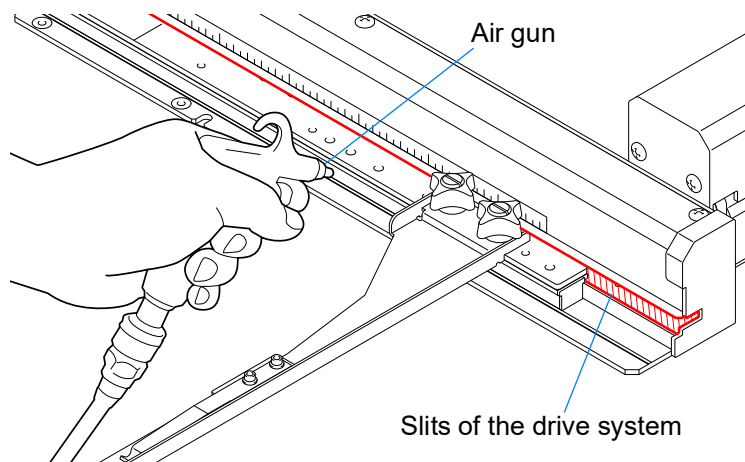

4. Lubrication

Perform lubrication using the supplied oiler.

⚠ WARNING

- ! Maintenance work should be performed by the personnel who is trained adequately.
- ! To prevent an accident due to an unexpected startup, be sure to turn off the power before accessing the machine.

⚠ CAUTION

- ! Use only TAJIMA's genuine TF oil or equivalent (Viscosity grade = VG20).
- ! Pour a few drops of oil for lubrication. Using too much oil may cause the oil to drip or scatter, possibly dirtying or staining the fabric or thread. Wipe off excess oil with a cloth.

4-1. Rotary hook

Frequency: Once per 5 to 6 hours



- To lubricate a lubrication hole, attach the nozzle (accessory) to the tip of the oiler.

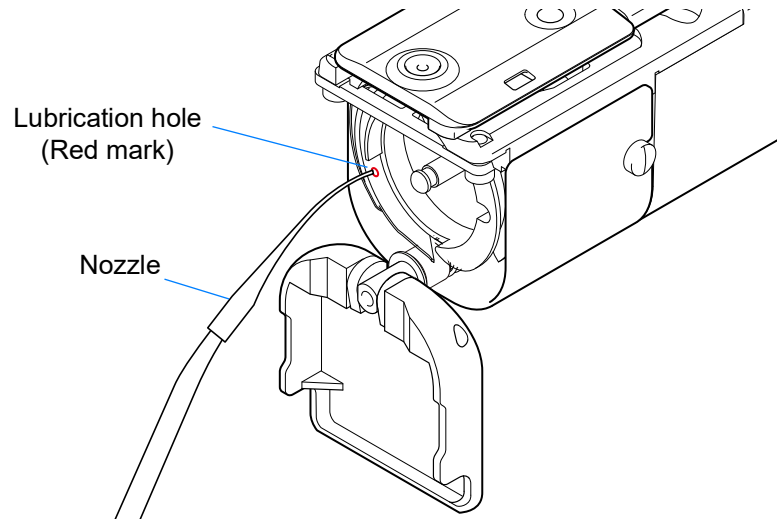

4-2. Inside of head

Frequency: Once a week

■ TMBR2-SC

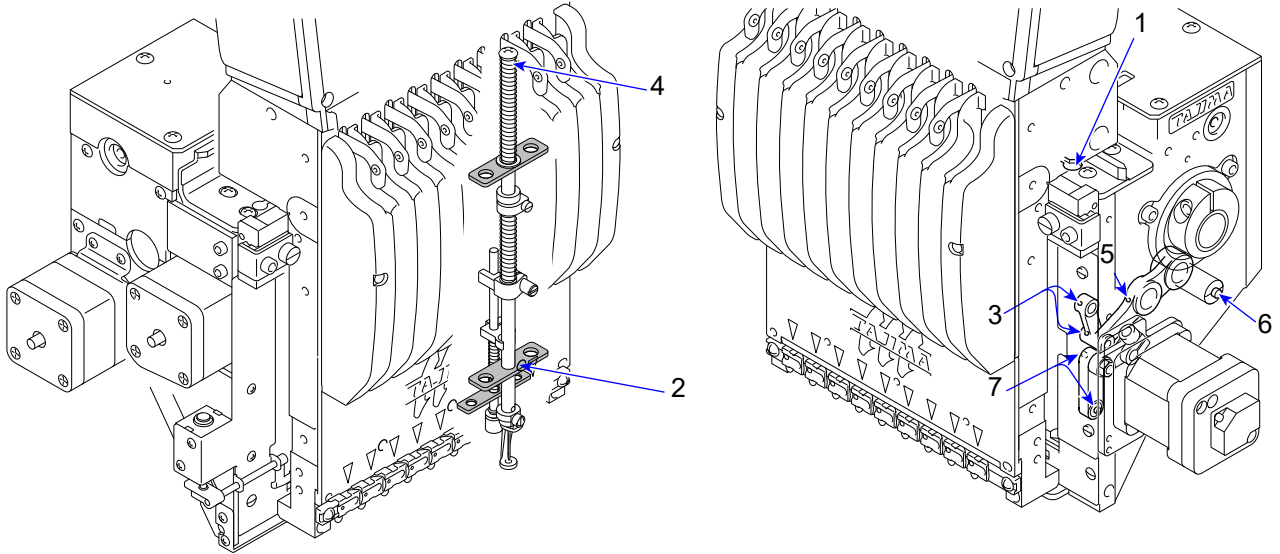

■ TMBP2-SC, TMBP2-XC

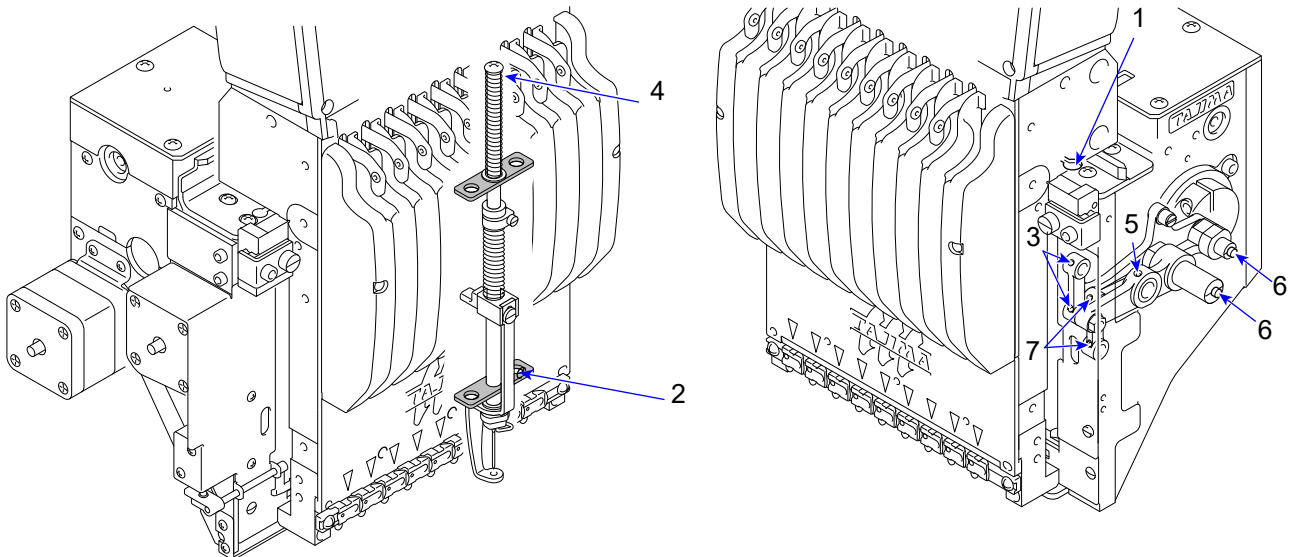

	Lubricating spot
1	Needle bar drive shaft
2	Needle bar, presser foot shaft
3	Lubrication hole of connecting part
4	Needle bar (all needles)
5	Lubrication hole of needle bar lever
6	Lubrication hole of stepped pin
7	Presser foot drive system

5. Greasing

This section contains information intended for use by service personnel assigned and trained by TAJIMA.

⚠ WARNING

- ❗ Greasing must be performed by the distributor or the service personnel assigned and trained by TAJIMA.
- ❗ To prevent an accident due to an unexpected startup, be sure to turn off the power before accessing the machine.

⚠ CAUTION

- ❗ Use a grease specified (described below) by TAJIMA or equivalent to keep the lubricity inside of the head normally. Use of grease other than above could cause trouble due to deterioration of the lubricity.

Manufacturer of grease specified by TAJIMA: NIPPON GREASE Co., Ltd.				
Parts to be greased	Part name	Item No.	Base oil	Thickener
Cylinder bed gear	KING STAR EP NO.2: 400G	750103004000	Refined mineral oil (about 75%)	Lithium soap (about 15%)
Inside of head	NIG LUBE PG: 300ML	750104001000	Olefinic synthetic oil	Lithium soap



- For questions regarding greasing and how to obtain grease, consult the distributor.

5-1. Cylinder bed gear

Frequency: Once every six months

Grease up the cylinder bed gears, using grease specified by TAJIMA.

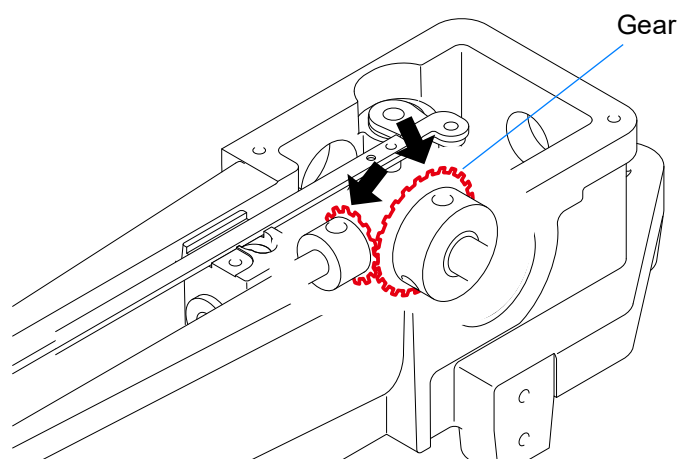

5-2. Inside of head

Frequency: Once every three months

Grease up the moving parts of the head, using grease specified by TAJIMA.

■ TMBR2-SC

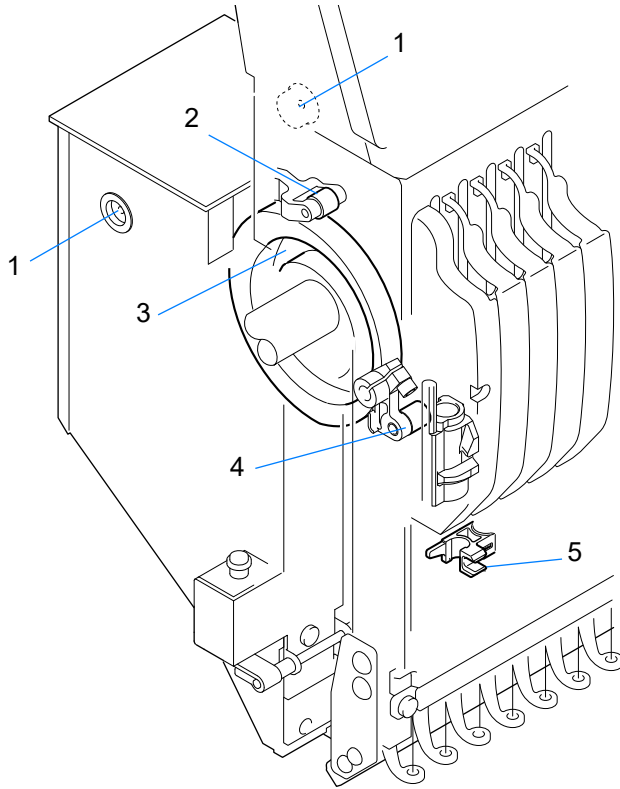

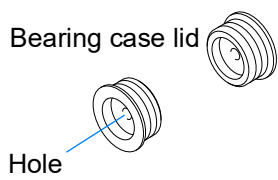
Greasing spot	
1	<p>Take-up lever shaft holder Inject grease from the hole in the bearing case lid, using a syringe.</p> 
2	Take-up lever roller
3	Take-up lever cam
4	Jump lever roller
5	Presser foot reciprocator

■ TMBP2-SC, TMBP2-XC

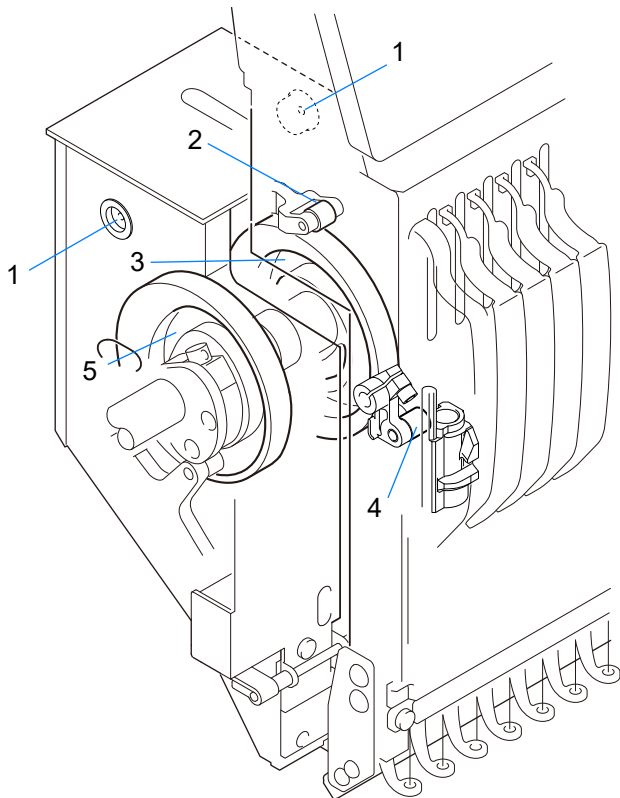

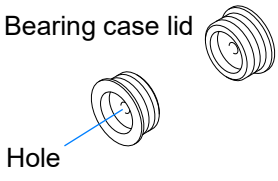
Greasing spot	
1	<p>Take-up lever shaft holder Inject grease from the hole in the bearing case lid, using a syringe.</p> 
2	Take-up lever roller
3	Take-up lever cam
4	Jump lever roller
5	Presser foot cam

6. Inspection and Repair

6-1. Inspection

⚠ WARNING

- ❗ Inspection of drive systems must be performed by the distributor or the service personnel assigned and trained by TAJIMA.
- ⚡ Before the work, turn OFF the power and remove the power plug from the outlet. Some circuits are supplied with voltage even after you remove the power plug. Wait until they are completely discharged (for at least 4 minutes), and then start the work.

⚠ CAUTION

- ❗ If the belt of the main shaft or drive system is loose or abnormal, consult your distributor.

Inspection point	Action	Inspection cycle
Attaching of each type of cover	Attach all covers.	When starting work
Setting condition of embroidery thread	Set the thread correctly.	
Check breakage and/or bent of needle.	Replace the needle.	
Lubricating condition of each section	Lubricate.	
Belt (Main shaft and X/Y drive system)	Each belt in main shaft drive system	Once every three months
	X- and Y-axis drive belts	
	Rotating, sliding section	

6-2. Repair

This section contains information intended for use by service personnel assigned and trained by TAJIMA.

⚠ WARNING

- ❗ Repair of the machine must be performed by the distributor or the service personnel assigned and trained by TAJIMA.
- 🚫 Do not change the specification nor modify the parts of the machine without due consultation with TAJIMA. Such modification may risk the operational safety.
- ⚡ Before the work, turn OFF the power and remove the power plug from the outlet. Some circuits are supplied with voltage even after you remove the power plug. Wait until they are completely discharged (for at least 4 minutes), and then start the work.

⚠ CAUTION

- ❗ For the machine repairs, use TAJIMA genuine parts for replacement.

7. Checking and Adjustment

This chapter describes how to check the height of the needle bar lower dead point and how to adjust the presser foot height.

⚠ WARNING

- ❗ Maintenance work should be performed by the personnel who is trained adequately.
- ❗ To prevent an accident due to an unexpected startup, be sure to turn off the power before accessing the machine.

⚠ CAUTION

- ❗ Take care to prevent the needle from sticking in your finger.

7-1. Checking the needle bar lower dead point

The machine is adjusted by default so that the needle bar reaches the lower dead point (the lowest point) when the main shaft angle is 178°. If you often encounter problems such as the frequent occurrence of thread or needle breakages or imperfect finish of sewing, the needle bar lower dead point may be incorrect. Check the status using the supplied lower dead point gauge.

The following example shows how to check the first needle bar.



- For the TMBP2-SC, TMBP2-XC, turn off the power of the machine and perform steps 5 to 10.

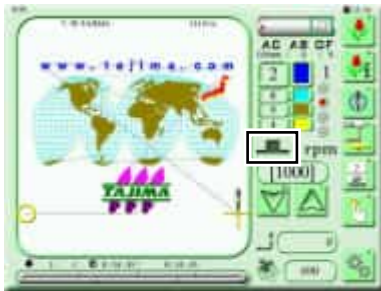

1 Set the needle position to the first needle.

2 Press  and hold to release the main shaft brake.

3 Press  for manual operation.

4 Press  to lower the presser foot to the presser foot lower dead point.



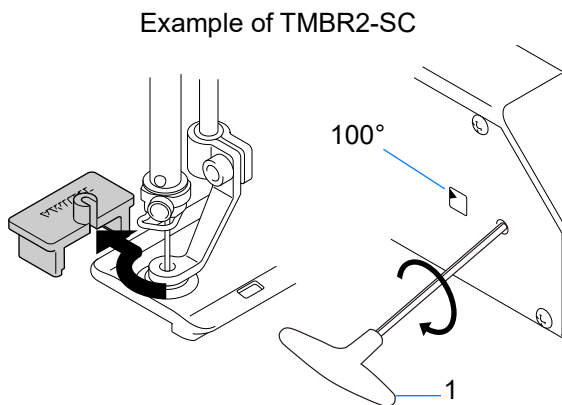
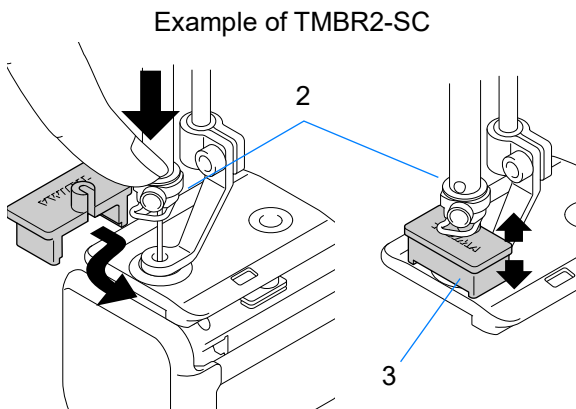
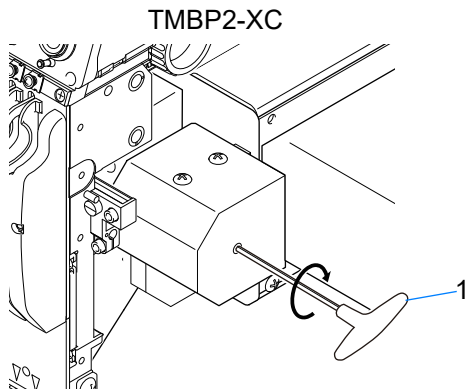
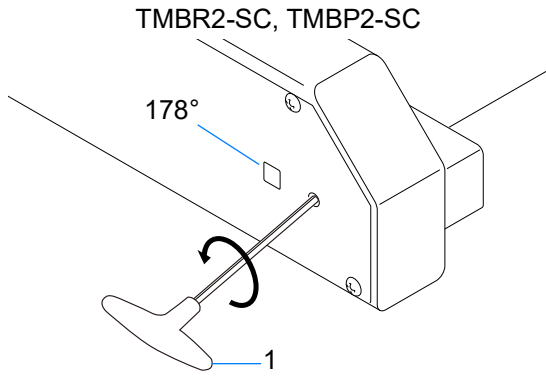

5 Insert hexagon wrench 1 (M6) into the left-hand side of the machine and turn the hexagon wrench counterclockwise to set the main shaft angle before 178° (the needle bar lower dead point).

Insert hexagon wrench 1 (M6) into the right-hand side of the head and turn the hexagon wrench clockwise to set the main shaft angle before 178° (the needle bar lower dead point).

6 Lower needle clamp 2 by finger and lower the needle bar.

7 Insert lower dead point gauge 3 into needle clamp 2 and turn hexagon wrench 1 slowly to 178°.

8 Check that lower dead point gauge 3 has no play.

9 TMBR2-SC, TMBP2-SC:
Turn hexagon wrench 1 a little clockwise to remove lower dead point gauge 3 when the needle bar is raised.

TMBP2-XC:
Turn hexagon wrench 1 a little counterclockwise to remove lower dead point gauge 3 when the needle bar is raised.

10 TMBR2-SC, TMBP2-SC:
Turn hexagon wrench 1 clockwise to set the main shaft angle to 100° (the stop position).

TMBP2-XC:
Turn hexagon wrench 1 counterclockwise to set the main shaft angle to 100° (the stop position).

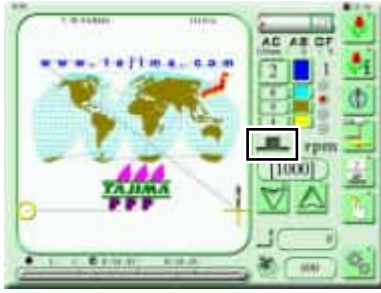

- 11 Press  and hold to excite the main shaft motor (MM).

7-2. Adjusting the stroke amount of the thread take-up spring

When you want to tighten or loosen the thread tightening, adjust the stroke amount of the thread take-up spring inside the middle thread guide.

■ Removing the middle thread guide

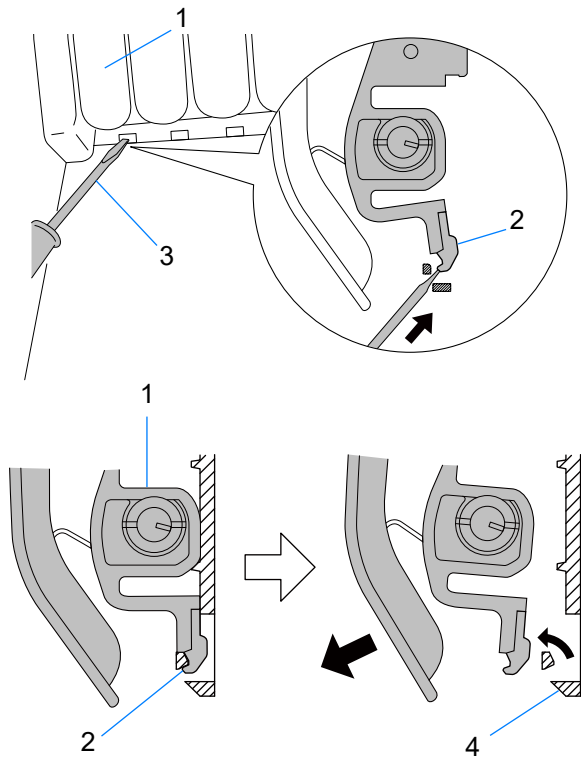

- 1 Remove middle thread guide 1 from top cover 4 by pushing pawl 2 with something like a stick with a sharp tip 3 and pull it toward yourself.

■ Stroke amount adjustment

Adjust the thread take-up spring stroke amount by turning the spring shaft using a coin or the like inserted into its groove.

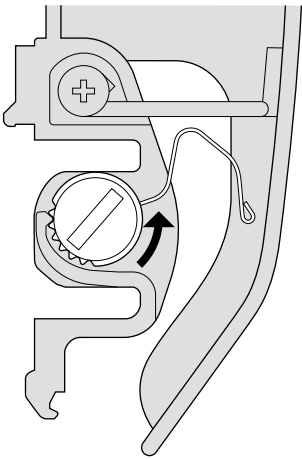
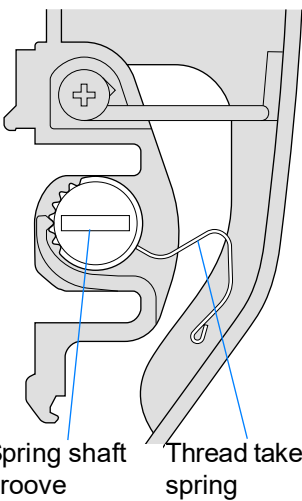
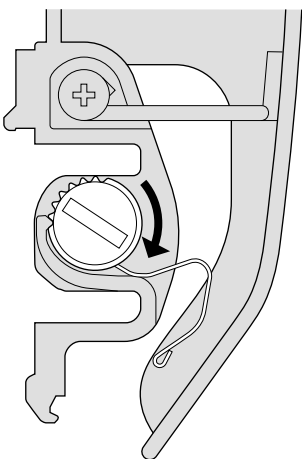
Thread tightening	Getting weak	Standard	Getting strong
Stroke	Minimum	Standard	Max.
Maximum adjustment	Three levels in the counterclockwise direction	Position by factory default	Two levels in the clockwise direction
Condition			

■ Installing the middle thread guide

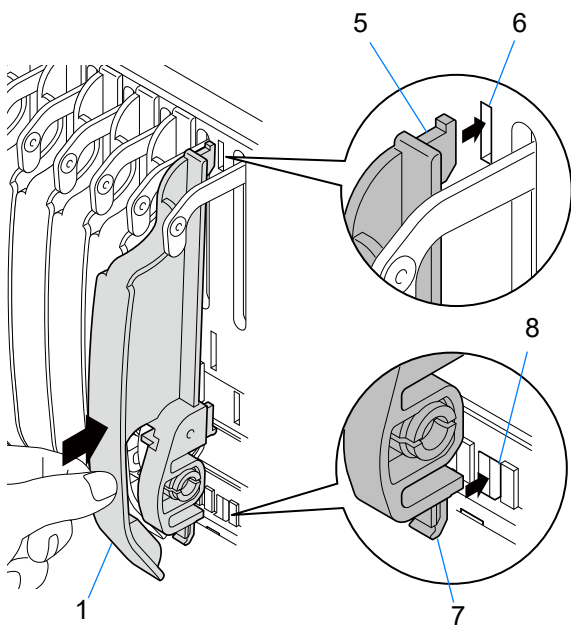

- 1 Insert upper pawl 5 of middle thread guide 1 into slit 6 and fit locking pawl 7 into hole 8 by pushing it up by finger.
- 2 Push middle thread guide 1 securely to fit until it clicks into place.

1

2

3

4

5

6

7

8

9

Chapter 8

Troubleshooting

1. Message Screen

When the machine stops during operation, a message screen appears on the operation panel (OP). Perform troubleshooting based on the code No. and message displayed on the message screen.



! WARNING

Code numbers affixed with * in the following table must be coped with by the distributor or the service personnel assigned and trained by TAJIMA. Failure to observe this may result in injury, electric shock, or other serious accident.

Cord	Stop factor	Corrective Action
0D4	Model setting mismatch Incorrect model setting.	Please check the model setting. Please install the system software.
1B1	Stop by frame stepping code. This stop is not caused by an error.	Perform "Start operation" or "Frame back/forward operation", or press any operation key to continue machine operation.
1B2	Stop by color change code This stop is not caused by an error.	
1B3	Stop by end code This stop is not caused by an error.	
1B4	Stop by thread trimming code This stop is not caused by an error.	
1B5	Stop by sequin code This stop is not caused by an error.	
1B6	Stop by automatic offset code This stop is not caused by an error.	
1B8	Stop by temporary stop code This stop is not caused by an error.	

Cord	Stop factor	Corrective Action
1C1	Stop by stop switch Machine stopped by operator's operation.	Continue the operation if needed. By turning OFF the main power during 1C1 indication, the embroidery may not be continued.
1D2	Preset halt Machine stopped by the preset halt setting.	Reset by pressing the reset key. Perform "Start operation" to continue the embroidery.
1D3	Stop for material processing Machine stopped by automatic stop setting for material processing.	Perform the material processing by material cutting and others if necessary. Continue machine operation if necessary.
1D8	Preset halt (ATH cleaning) Machine stopped by the preset halt setting.	Clean the inside of the cylinder bed after resetting by pressing the reset button.
211-01	Fixed position signal error Machine stopped at other than the fixed position of main shaft.	Return main shaft to the fixed position. Check adjustment of encoder/encoder Z signal.
221	Frame Too Far Left Embroidery frame moved to the limit position (left). (+X direction)	Move the frame manually to embroider within the setting of embroidery space.
222	Frame Too Far Right Embroidery frame moved to the limit position (right). (-X direction)	Move the frame manually to embroider within the setting of embroidery space.
223	Frame Too Far Front Embroidery frame moved to the limit position (front). (+Y direction)	Move the frame manually to embroider within the setting of embroidery space.
224	Frame Too Far Back Embroidery frame moved to the limit position (rear). (-Y direction)	Move the frame manually to embroider within the setting of embroidery space.
225	Design size too large Design does not fit within the embroidery space due to the present start position of design.	Move the frame manually to embroider within the setting of embroidery space.
229	Frame power resume incomplete Frame power resume is incomplete.	Perform the operation of frame power resume.
291	Upper Thread Break Machine detected upper thread breakage.	Check the upper and under threads. Check/replace the tension base card.
293	Under Thread Break Machine detected under thread breakage.	Check the under thread. Check/replace the tension base card.
2B1	Network anomaly (hardware) Not connected to the network.	Check the status of the LAN cable connection and the settings of the PC and other devices.
2B3	Data found in end code Data is found in end code.	Delete "X/Y moving amount of the end code" of the design data.
2B4	Function code error Function code error occurred.	There is a function code that is not defined. Correct the design data.

1. Message Screen

Cord	Stop factor	Corrective Action
2B7	Data set incomplete Data set is not completed.	Operate the machine after setting the data of embroidery design.
2B8	Pre-reading Buffer error Output data could not be prepared.	Frame forward is not available beyond the current stitch count. When being in operation, lower the revolution.
*2B9	Memory write error Cannot write data into memory.	Check/replace CPU card/operation panel (OP).
2BA	Memory capacity exceeded Free space of memory is insufficient.	Increase the free space of memory by removing unnecessary designs in the registered in the memory (after backing up if necessary).
2BB	Frame Back limit over Frame Back exceeded available range.	Frame back is not available before the current stitch count.
2BC	Design No. error Design No. cannot be found. Not editable due to data setting. Design is not registered in memory.	Edit the design you wish to edit after the data set of the design. Register the design to the memory.
2BE	Incorrect function code segment Start/End codes is not registered in a pair for the function which has Start/End.	Modify/set the design so that the codes of Start/End become a pair.
2C2	Insufficient Option Device Setting The option device setting is wrong.	Check Option Device is properly set.
2C7	Password requested Password is requested. The input password is wrong.	Input the password.
2C9	Time setting error	Press the reset key on the operation panel (OP).
2CE	Stop by safety device Machine was stopped by the stop signal from the safety device.	After confirming safety, continue machine operation if needed.
2E2	Air pressure error Air pressure has become lower than the standard level.	Check/adjust the pressure of air supplying.
2E3	Power failure during operation The power supply was shut off during main shaft operation.	Perform the operation of power resume.
*312-01	Encoder Z signal error [Controller card] Encoder Z signal does not vary.	Check the encoder/encoder signal line.
*316-01	Main shaft motor (MM) error [Deviation error] Main shaft motor (MM) or Motor driver is irregular.	Turn OFF/ON the main power.
*322	X-Driver irregular signal X-axis Driver irregular signal, detected.	Turn OFF/ON the main power. Check/replace the X-axis driver card.

Cord	Stop factor	Corrective Action
*323	Y-Driver irregular signal Y-axis Driver irregular signal, detected.	Turn OFF/ON the main power. Check/replace the Y-axis driver card.
32C	X-axis frame travel incomplete X-axis frame travel is incomplete.	Turn OFF/ON the main power. Check/replace the X-axis driver card.
32D	Y-axis frame travel incomplete Y-axis frame travel is incomplete.	Turn OFF/ON the main power. Check/replace the Y-axis driver card.
32E	X-axis origin search incomplete X-axis origin search is incomplete in time.	Check the embroidery space setting. Check/replace the sensor card.
32F	Y-axis origin search incomplete Y-axis origin search is incomplete in time.	
376	Presser foot position error Presser foot position is Irregular.	Set the presser foot to the retractable position.
*378-**	Presser foot driver error Presser foot driver irregular signal, detected.	Turn OFF/ON the main power. Lower the revolution of main shaft. Check/replace head card.
*382-01	Time is over to move to target position. CS adjustment at power ON is incomplete within 4 seconds.	Check/replace the color change motor/encoder and potentiometer (needle position sensor).
*383-01	Needle position error Needle position is outside of the set range (beyond the 1st needle and the last needle) at the start of main shaft drive.	Move the needle position within the set range. Check/replace the potentiometer (needle position sensor) or color change encoder.
*3A6	Movable Knife Open ATH Knife retractable position has become nonuniform.	Check the position of ATH movable knife.
3AB	ATH thread separation error	Press the reset key on the operation panel (OP).
3AC	ATH Skip stitch error	
*3C1	Start/Stop switch error The power was turned ON in the state that the stop switch has been accidentally pressed.	Check/replace the connector/connection terminal/limit switch. Turn OFF/ON the main power.
*3DB	System RAM insufficient capacity	Turn OFF/ON the main power. Install the system software. Check/replace CPU card.
*3DC	Memory device error	Turn OFF/ON the main power. Install the system software. Check/replace CPU card.
*3DD-**	System installation error	After pressing the reset key, install again by pressing the retry key. After turning OFF/ON the main power, install again. Check/replace CPU card.
*3DE	External memory device error External memory media such as a USB memory has abnormality.	Turn OFF/ON the main power. Check/replace the external memory media. Check/replace CPU card.

1. Message Screen

Cord	Stop factor	Corrective Action
*3DF	Memory device broken Memory device is broken.	Turn OFF/ON the main power. Check and replace CPU card.
5B1	Design information error Design data of TCF Format cannot be input.	Replace the design data. Use the design data made by DG/ML.
5B2	Network anomaly (software) Not connected to network software.	Check the status of the LAN cable connection and the settings of the PC and other devices.
5C1	Frame origin memory incomplete Frame origin memory is incomplete.	Perform the operation of absolute origin search.
5C6	General external device is operating.	Do not operate the machine during the operation of general external device.
*6B5-**	Communication error	Turn OFF/ON the main power. Install the system software. Check/replace each card.
6D1	Frame parameter file error Frame parameter file is irregular.	Install the system software.
BC1	Unregistered design No. Design No. is not found.	Perform the selection of design again.
OIL	Preset halt (Lubrication) Machine stopped by the preset halt setting (Lubrication) .	After lubricating the necessary spots, reset the machine by the reset key. Continue to embroider by starting machine.

2. When the Machine Does not Sew Well

If the machine does not sew well, investigate the cause with reference to the following.

If the cause is unknown or the problem recurs, consult the distributor.

2-1. Frequent thread breakages

Cause	Troubleshooting
Improper thread tension	Adjust the friction. Upper thread = 120 to 140 g, under thread = 20 to 30 g
Poor thread flow	Use silicone.
Direction of needle is bad or needle bents.	Adjust to face to the front or to the right a bit. Replace the needle.
Applique glue is stuck on needle.	Remove adhered glue.
Lint, run-out of oil of rotary hook	Clean and lubricate.
Numerous tiny stitches of 0.5 mm or less in the design	Remove tiny stitch(es).
The fabric is lifted too much against the needle plate. The fabric touches the needle plate too much.	Replace the clips. Stretch the fabric again so that it touches needle plate lightly.
Run-out of oil of needle bar	Lubricate.
There is a scratch on the thread course and /or rotary hook.	Grind a scratch with sandpaper etc. Replace the rotary hook or the thread course.
Bad height of presser foot	Perform adjustment so that height fits to fabric/material.
The combination of Frame drive timing and embroidery condition is inappropriate.	Change setting.

2-2. Needle breaks

Cause	Troubleshooting
Improper thread tension	Adjust the friction. Upper thread = 120 to 140 g, under thread = 20 to 30 g
Density of design data is very high	Correct design data. Delete unnecessary underlay stitching.
The material is too thick or hard.	Use material suitable for embroidery.
Bobbin is deformed and the needle touches it.	Replace the bobbin.
Deterioration of needle, mis-matching to embroidery condition	Replace needle. Use needle that fits to condition.
Vibration of the machine is big.	Center support is applied too much. Tighten the support by hand. Adjust leveling.
The combination of Frame drive timing and embroidery condition is inappropriate.	Change setting.

2-3. Embroidery results not good

Cause	Troubleshooting
Improper thread tension	Adjust the friction. Upper thread = 120 to 140 g, under thread = 20 to 30 g
Poor thread flow	Use silicone.
Density of design data does not match with material and/or thread.	Correct design data.
Bad frame attaching and fixing of the fabric	Attach the frame correctly. Fix the fabric firmly.
The combination of thread, needle and/or the size of needle plate is inappropriate to the embroidery condition.	Make combination that fits to design/material.
R.P.M. is too high.	Decrease R.P.M.
The combination of frame drive timing and embroidery condition is inappropriate.	Change setting.

3. Power Resume after Power Failure

If the power is shut down due to power failure or emergency stop during embroidery, turn ON the power and perform power resume.

⚠ CAUTION

- ⊘ Do not put your hands on the table when you operate the machine because doing so may cause your finger or hand to be injured when the needle bar or frame moves.



- 1 Press  on the message screen.

The power resume method selection screen appears.

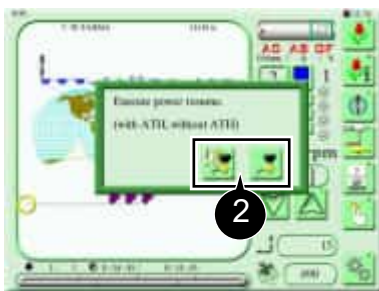

- 2 Select the power resume method.



:Perform power resume after trimming the thread.



:Perform power resume without trimming the thread.





- When you perform power resume, the machine checks the absolute origin and the frame moves to a position several stitches back from the position where it was when the power was turned OFF.

4. Obtaining Log Data

Machine operation history and communication history are recorded as machine logs.

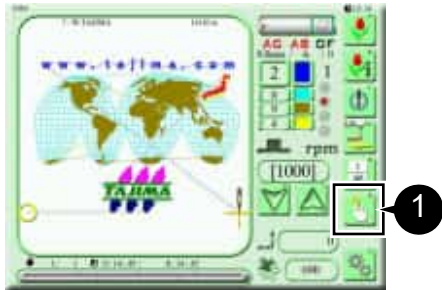
If the distributor requests you to provide log data for the purpose of investigating the cause of trouble, save the log data in a USB memory.



- 1 Insert the USB memory into the USB port of the operation panel (OP) and then press  on the main screen.

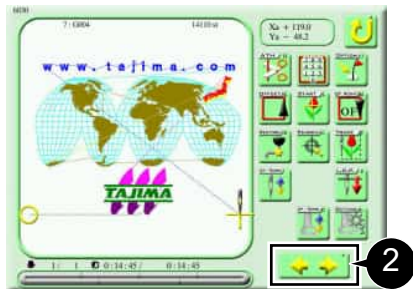

- 2 Press .



- 3 Press .



- 4 Press . The log data saved on the CFast card in the operation panel (OP) and the log data you have obtained will be saved on the USB memory.



- Pressing  saves log information on the CFast card in the operation panel (OP) up to 50 times. After exceeding 50 times, existing log information will be overwritten.

- 5 Remove the USB memory from the USB port.

Chapter 9

Appendix

1. Improving the Sewing Finish Quality (FS Mode)

FS mode improves the finish of sewing even if you use badly passing thread (the tinsel, the thick thread) or loosely twisted thread.

This function is especially effective for the embroidery using loosely twisted thread that was improper for the embroidery machine.



- You can configure FS mode with a parameter. For details, refer to the separate "Parameter Setting" manual.

1-1. Outline of function

■ Improvements by FS mode

- Decrease of thread breakage (Tinsel)
- Improvement of thread tightening for satin stitch (Loosely twisted thread, Thick thread)
- Stabilization of satin stitch (Loosely twisted thread)
- The balance between the upper thread and the under thread is stable on the back of the fabric. (All thread types)
- Decrease of bad thread tightening points of the emblem embroidery (Polyester yarn)



- The above information is not applicable to all embroidery conditions. No improvement may be gained under certain embroidery conditions.

■ Movement of the machine in FS mode

FS mode is the function giving priority to the embroidery quality. Therefore, the productivity may lower under the following conditions.

Use it after understanding the following.

- Maximum RPM should be limited.

1-2. Sewing comparison

■ Sewing comparison by the difference between standard mode and FS mode

Thread type: Rayon 300 d/1

FS Mode



Standard mode



■ Sewing comparison by the difference of threads

The following sewing samples (A, B, and C) were embroidered in FS mode. Even if you use a loosely twisted thread, you can perform embroidery as shown in samples A and B.



- If samples A and B (especially A) are embroidered in standard mode, problems such as fluffing and looping could occur.

Loosely twisted thread
(Rayon 300 d/1)



Thread twisted a little looser
(Middle level of twist between A and C)
(Polyester 120 d/2)



Normal embroidery thread
(Rayon 120 d/2)



1-3. Making use of optional parts

We prepare optional parts to improve the embroidery finish.

Consult your TAJIMA distributor to select optional parts that best suit the threads you plan to use and your fabric embroidery conditions.

■ Examples of using optional parts

Embroidery conditions	Optional parts
In case of using tinsel	Thread guide
In case of using the thick thread	Dedicated needle plates
In case of using loosely twisted thread	Dedicated needle plates, thread guides, dedicated needles

* Optional parts may not be applicable to your conditions, depending on the threads, designs, and fabric you use.



- Thread guides, dedicated needles and needle plates are not set products.
- As a sample items, thread guides and needles for 2 needles come with the machine.

■ Thread guide

In case of using badly passing thread, the upper thread tension will be too tight. Therefore, detach the spiral tube, and attach this thread guide.

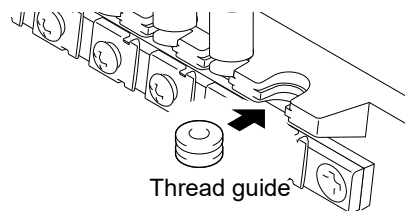

Part name	Part No.
THREAD GUIDE :2.2 MM DIA.	516501040000



- When the color change having large slide volume is performed, the thread tangle sometimes occurs.

■ Dedicated needles

Needles developed specially for FS mode. They are effective for loosely twisted threads that would otherwise be conventionally difficult to embroider.

Part name	Part No.
NEEDLE :DB-K5Z1 FS #11 U	616500570000
NEEDLE :DB-K5Z1 FS #11 Y	616500580000
NEEDLE :DB-K5Z1 FS #14 U	616500590000
NEEDLE :DB-K5Z1 FS #14 Y	616500600000



- Not suitable for the fabric that requires strong force that the needle penetrates through.

2. Upgrading the Software Version

The latest software is installed in this machine at the shipment. When it is necessary to upgrade the software later, install the latest software.

Regarding the contents and how to obtain the latest software, please consult the distributor.



- This operation requires input of the password. After you enter the password, you can perform the following operations until you turn off and back on the power. For details, consult the distributor.

■ Explanation on the screen

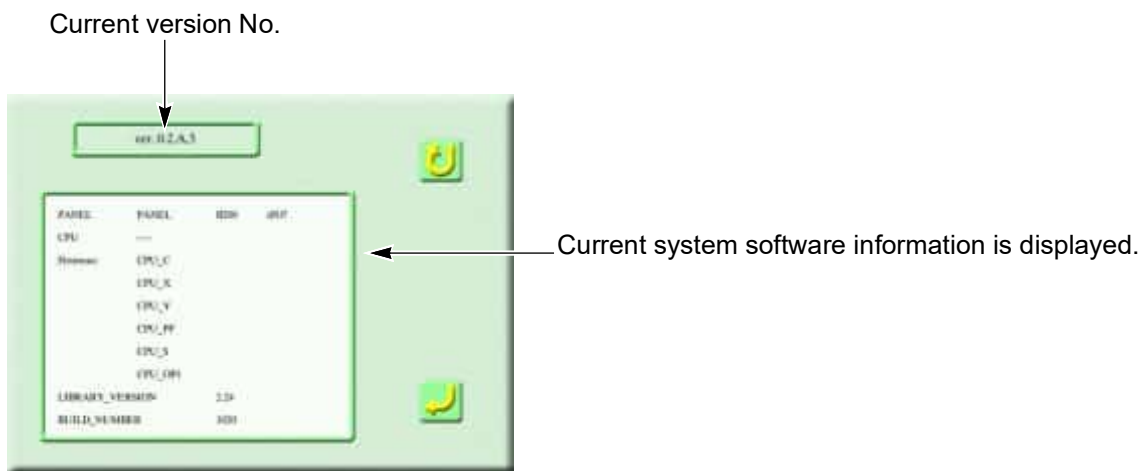

■ How to operate

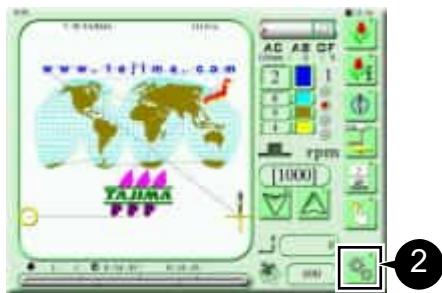

1 Insert a USB memory containing software into the USB port on the operation panel (OP).

2 Press  on the main screen.

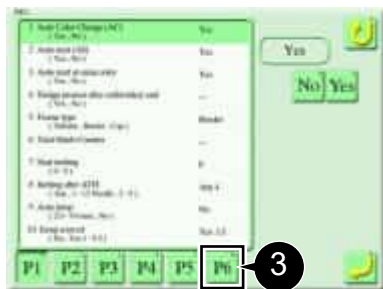

3 Press  twice.



4 Press 

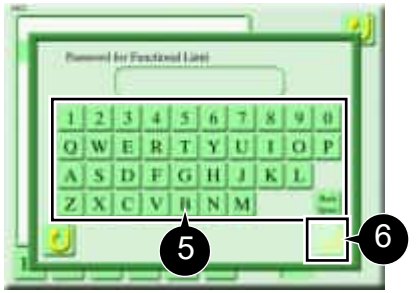

5 Input a password.

6 Press 



7 Press 

8 Press 



9 Press 



10 Select "85. Machine adjustment".

11 Press 

1

2

3

4

5

6

7

8

9

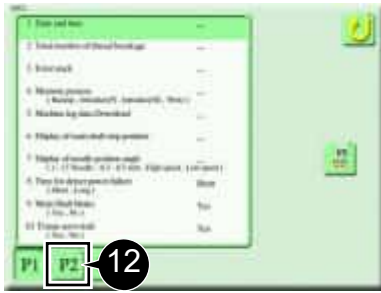

12 Press .



13 Select "15. Software install".



- If the software installation is not displayed, refer to "Display/hide each parameter item" in the separate "Parameter Setting" manual.



14 Press .



15 Press .



16 Select your desired software.

17 Press .



18 Select the installation method.

Default : Install only the necessary system

ALL Yes : Install all the systems



- To overwrite the same software, select

ALL Yes

19 Press .



20 After the message is displayed, turn on the power again with the USB memory inserted.



- To turn ON the power again, wait for 10 seconds or more.
- Do not remove the USB memory during the software installation process.

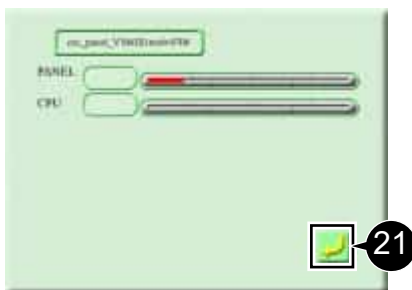

21 Press .

The software is installed.



22 After the completion screen appears, remove the USB memory from the USB port of the operation panel (OP).

23 Turn ON the power again.



- To turn ON the power again, wait for 10 seconds or more.

3. Specifications

3-1. Electrical specifications

	TMBR2-SC	TMBP2-SC	TMBP2-XC
Rated current	1.4A (120V)	1.5A (120V)	1.8A (120V)
Maximum power	160W	190W	200W
Apparent power	180VA	210VA	210VA
Allowable voltage range	Within $\pm 10\%$ of the rated voltage		
Frequency	50 / 60 Hz		
Insulated resistance	10 M ohms or greater (500 megger insulation tester)		

3-2. Ambient noise level

The ambient noise level of the machine is less than 85 dB. Measuring conditions are as follows.

Measuring ambience	Refer to the right illustration.
Measuring position	Measured at position A at a height of 1.6 m from the floor and a distance of 1.5 m from the needle locating position
Working machine condition	Fabric is stretched on the border frame, and embroidered a design which has 4 mm width.
RPM	Maximum number of revolutions of machine
Measuring instrument	Compliant to IEC61672-1: 2002 Class 1

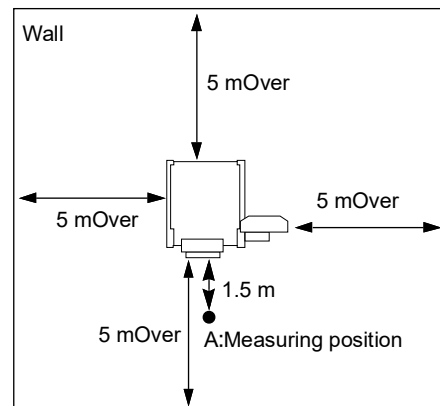

3-3. Machine weight

TMBR2-S1501C(360x500)S	95kg (Net weight)
TMBP2-S1501C(360x500)S	
TMBU2-S1501C(360x500)S	140kg (Net weight)
TMBP2-X1501C(550x600)S	120kg (Net weight)

4. Electrical Block Diagram

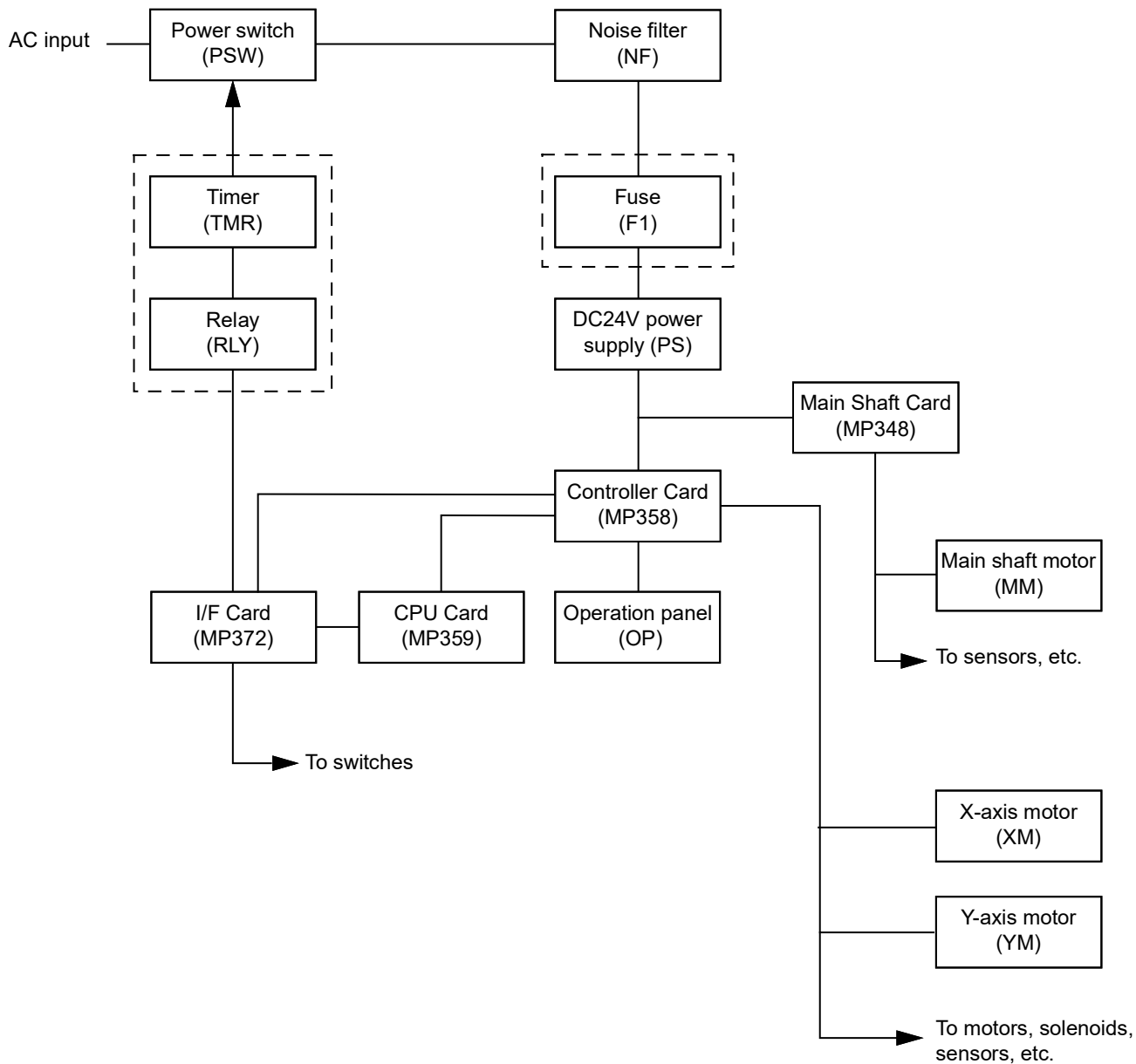

 Only for CSA spec.

5. Terminology

The following terms are common to all the models. They may not apply to some models.

<A>

Absolute origin

An anchoring point to calculate the current frame position (Xa + 0.0, Ya + 0.0).

ATH

The abbreviation of Automatic Thread Trimming and Holding Device.

Auto Jump

To make a stitch divided into two stitches as less than setting value automatically when its stitch length exceeds the setting value. It is effective to prevent the slippage of the frame and the displacement of the design.

Backlash

A play (gap) generated at the drive system and/or around the frame by shock when a stitch returns (when frame drive is reversed). It may affect embroidery finish.

<C>

Cleanup

To remove tiny stitches included in design data to make before and after stitches absorb it. It has an effect on decreasing thread breakages.

Condition data (CT0)

Embroidery condition included in the design (needle bar selection, data conversion, repeat, start position, automatic offset).

CT0

File including the information of needle bar selection and start position. It is necessary to handle TBF, CT0, and DGF as a set on a personal computer.

<D>

Data mode

Saving format of design (T, T2, T3).

Data set

To set the design data in the memory of the machine to start the machine.

D-axis

Driving shaft to rotate sewing needle and N-PIPE (TCMX series).

DG by Pulse

Embroidery design creation software developed by Pulse Microsystems Ltd. It provides the ability to quickly convert vector data to stitches. It also provides the ability to send designs to the machine by connecting DG by Pulse to the machine via LAN.

DGF

File that indicates design image. It is necessary to handle TBF, CT0, and DGF as a set on a personal computer.

Driver

Control card to make the frame or main shaft drive. X-axis driver, Y-axis driver, main shaft driver, etc. are included.

DST

Stitch data for Tajima ternary format. Data saving format is T.

<E>

Excitation

To keep frame motor drive. It is not possible to move the frame by hand during excitation.

<F>

Fine stitch

Fine stitch as a factor causing thread breakage. Stitch of which the stitch length is 0.5 mm or less.

Fixed pitch movement

Horizontal frame travel to the neighboring head by head interval.

Fixed position

Angle of the main shaft at which the main shaft motor(MM) stops (stop position).

Frame Back

To move the embroidery frame only to the direction where the stitches return with the needle bar(s) stopped.

Frame coordinates

Frame position in embroidery space. It is indicated like "X: -153.2, Y: +120.4".

Frame Forward

To move the embroidery frame only to the direction where the stitches advance with the needle bar(s) stopped.

Frame Limit

Limit position that the frame can move (it is indicated by mark-off line on the table).

Frame stepping

To move the embroidery frame only with the main shaft of the machine is stopped during embroidery.

Function Code

Command code that controls general movements of the machine. All design data consists of function codes (Stitch, Jump, Color, etc.).

<H>

Head group

Function that assumes multiple heads as one head by grouping them. This enables large design embroidery or multi-color embroidery with more colors than the number of needles per head.

<I>

Inching

Movement to stabilize start of sewing by moving needle bar slowly before the main shaft enters normal operation. It is also executed before thread trimming to stabilize thread trimming.

<J>

Jump

To make only the frame move in the state that needle bar does not move down during operation. It is possible to make a longer stitch than one stitch of the maximum length.

<M>

Main shaft brake

To hold the main shaft with the brake of the main shaft motor(MM) so that the main shaft does not rotate when it stops.

M-axis

Drive shaft to rotate N-PIPE and bobbin (TLMX series).

<O>

Offset start position (Offset position)

Frame travel start position that is configured by operating the Automatic Offset. The position to make the frame stand by to facilitate changing of frame and/or fabric by moving the frame to the front automatically in the middle of sewing or at the end of sewing.

<P>

Parameter

Setting items that decide the working condition of the machine.

Pseudo-fixed position (stop at the lower dead point)

The machine should be stopped with the needle stuck in the cloth at the end of embroidery. Moving the frame in this condition will enable consecutive embroidery.

1

2

3

4

5

6

7

8

9

<R>

Return stitches

Tie stitch to be executed at start of sewing (stitch to prevent mis-stitching at start.).

Running stitch

Decorative stitch of straight line or curved line only.

<S>

Satin Stitch

Repeated zigzag stitches. It is mainly used for hem of applique, logo, mark, flower design, etc.

Seed beads needle

Needle that embroiders with beads by seed beads device. It indicates the first needle or the last needle.

Sequin needle

Needle that embroiders with sequins by sequin device. It indicates the first needle or the last needle.

Step

The section divided by a color change code in the design. The first section is called Step 1 and the next section is called Step 2.

<T>

Table offset

To move the frame to the rear direction temporarily to facilitate threading. It is mainly effective when the frame is positioned at the table cut section.

Tatami stitch

Stitches to fill in a certain amount of area. They are mainly used for a big logo, background, underlay etc.

TBF

Stitch data for Tajima binary format. Data saving format is T2. It can support more function codes than DST. It is necessary to handle TBF, CT0, and DGF as a set on a personal computer.

TCF

Data that integrates TBF, CT0, and DGF. Integration facilitates handling of designs. Data saving format is T3.

Tie stitches

Tie stitch to be executed before thread trimming (stitch to prevent fray).

<X>

X-axis drive system

Drive system to make the embroidery frame move in the horizontal (X) direction.

X data

The data that makes the embroidery frame move right/left direction (X direction). It is indicated by moving direction (code: +/-) and the value (mm).

<Y>

Y-axis drive system

Drive system to make the embroidery frame move in the vertical (Y) direction.

Y data

The data that makes the embroidery frame move front/rear direction (Y direction). It is indicated by moving direction (code: +/-) and the value (mm).

<Z>

Z-axis

Drive shaft to change needle height (TCMX series).

1st edition November 2022

2nd edition August 2024

■ **Manufactured by: TISM Co.,Ltd.**

NO.1800, Ushiyama-cho, Kasugai, Aichi-pref., 486-0901, Japan
Telephone: 81-568-33-1161

■ **Distributed by: Tajima Industries Ltd.**

NO.1800, Ushiyama-cho, Kasugai, Aichi-pref., 486-0901, Japan
Telephone: 81-568-37-1130