



USER'S MANUAL

# Operation

This manual describes the procedures for operating the machine, performing embroidery, and performing maintenance.

# TMCR-VF



# Foreword

Thank you for purchasing a TAJIMA embroidery machine.

Please read this manual thoroughly, understand the contents, and then use the machine.

This manual may contain discrepancies in detailed specifications when compared with the actual product. If you have any questions, please ask your distributor for information.

## Purpose of This Document

This manual and other documents contain the following information. Refer to the necessary documents depending on the application and purpose. The user's manual and other documents are stored as PDF files on the CD that comes with your machine.

### ■ USER'S MANUAL



For Safe Use	This manual contains instructions on using the machine safely. Make sure to read the manual before use.
Basics	This manual describes the basic knowledge and procedures that are common to all models and required to use the machine. If you are a novice to or unfamiliar with the machine, be sure to read this manual first.
Operation (this document)	This manual describes the procedures for operating the machine, performing embroidery, and performing maintenance.
Parameter Setting	This manual describes various parameters.
Frame Change	This manual describes how to change the frames. These do not come with some models.
Various Documents	Electrical system diagrams and other technical documents.

### ■ Other manuals

Quick Guide	This sheet is for quick reference regarding embroidery methods as well as frequently used functions and their operation procedures. Keep the Quick Guide handy so that you can access it quickly.
Optional Device	This manual describes how to set up, operate, and maintain various optional devices.

# Safety Precautions and Symbols



Items that require your special attention while operating the machine are specified below.

Description	Meaning
 <b>DANGER</b>	Indicates that there is a lot of danger of death or serious injuries* <sup>1</sup> .
 <b>WARNING</b>	Indicates that there is a likelihood of death or serious injuries* <sup>1</sup> .
 <b>CAUTION</b>	Indicates a potentially hazardous situation which may result in minor or moderate injury* <sup>2</sup> or physical damage.



\*1: A condition caused by electric shock, injury, fracture of a bone etc. that leads to aftereffects, or an injury that necessitates hospitalization or visits to a hospital over a long period.

\*2: An injury that does not necessitate hospitalization or visit to a hospital over a long period.

The symbols used throughout this document have the following meanings.

Symbol	Meaning
	Prohibited items
	Items that may cause electric shock if not observed
	Items to maintain safety

## Other Precautions

Description	Meaning
	Items that may affect embroidery if not observed.
	Recommended and useful tips.



## Disclaimer, etc.

- The external views and specifications of the machine and the contents of this manual are subject to change without notice due to improvement.
- The screen captures and figures contained in this manual may differ depending on the machine specifications, the number of heads or needles, and the presence of optional devices.
- TAJIMA bears no responsibility regarding any damage arising from not observing the instructions in the manual or any fault or damage resulting from repair, disassembly, or modification not indicated in the manual.
- You may not copy, reproduce, or transcribe in its entirety or any part of this manual without the consent of TAJIMA.

# About Functional Limit

To prevent unauthorized data exporting and parameter setting tampering, functional limit levels are used to restrict access to particular functions.

The following functions are restricted at each functional limit level.

Functional limit level	Limit contents
	<p>No limit</p> <ul style="list-style-type: none"><li>• All parameters are displayed</li><li>• All functions are enabled</li><li>• Parameter display is freely selectable</li></ul>
	<ul style="list-style-type: none"><li>• Only certain parameters (pages P1 to P6) are displayed <sup>*1</sup></li><li>• Downloading designs to a USB memory is not possible</li><li>• Design data in the machine memory is protected from editing (Insertion of stitch, deletion of stitch, modification of stitch)</li><li>• Detailed settings for step unit settings are hidden (Satin Stitch (area), Satin Stitch (density), Satin Stitch (expansion))</li></ul>
	<ul style="list-style-type: none"><li>• All parameters except for "2. Functional Limit Level" on page P8 are hidden</li><li>• Downloading designs to a USB memory is not possible</li><li>• Design data in the machine memory is protected from editing (Insertion of stitch, deletion of stitch, modification of stitch)</li><li>• Detailed settings for step unit settings are hidden (Satin Stitch (area), Satin Stitch (density), Satin Stitch (expansion))</li></ul>

\*1: Press P6 twice to display "2. Functional Limit Level" on page P8.

- The functional limit level is set to  at shipment. Changing the functional limit level requires you to enter the password.  
For details, consult your distributor.

# Basic Machine Operation

---

1. Turning the Power ON/OFF .....	13
1-1. Turn ON the power .....	13
1-2. Turn OFF the power .....	14
1-3. Lock the power switch .....	14
2. Start and Stop the Machine .....	15
2-1. Start the machine .....	15
2-2. Stop the machine .....	15
3. Multi-color LEDs .....	16
4. Direct Command Switch .....	17
5. Screen Operations .....	19
5-1. Changing the display background color .....	20
5-2. Main screen .....	21
5-3. Design selection screen .....	22
5-4. Description of basic icons .....	23
6. Frame Travel .....	25
6-1. How to move the frame .....	25
6-2. Changing the travel speed .....	26
6-3. Checking the frame position (coordinates) .....	27
7. Data Input/Output .....	28
7-1. Connecting a USB memory .....	28
7-2. Connecting a LAN cable .....	29
8. Table Offset Switch (Some Models) .....	30
8-1. Move the frame to the table offset position. ....	30
8-2. Return the frame to the previous position. ....	31

## How to Embroider

---

1. Basic Flow of Embroidery	32
2. Embroidery Procedures	33
2-1. Saving designs into the machine memory	33
2-2. Selecting the embroidery design (data setting)	35
2-3. Configuring the needle bar steps	37
2-4. Design confirmation	38
2-5. Setting the embroidery speed (high-speed R.P.M.)	39
2-6. Checking the embroidery position (execution of trace)	40
2-7. Starting embroidery	42
2-8. Completion of embroidery	43
3. Making Use of the DCP	44
3-1. Presser foot setting items	44
3-2. About the setting operation	46
3-3. Settings on the needle bar setting screen	47
3-4. Settings on the manual operation screen	48
4. Responding to Thread Breakage	49
4-1. How to respond to a thread breakage indicator	49
4-2. Repair stitches	50

## i-TM

---

1. Features of the i-TM System	52
2. i-TM Setting Screen	53
2-1. Auto mode	53
2-2. Manual mode	54
3. Adjusting the Embroidery Finish	55
3-1. Adjusting the thread tightening	55
3-2. Adjusting the thread tightening during operation	57
4. Storing the Control Pattern (Pattern Number)	59
4-1. Storing the control pattern with a name	59
4-2. Overwriting and saving the control pattern	60
5. Step Division	61
5-1. Step division and setting	61
5-2. Deleting a divided step	63

6. Resetting of the Control Pattern .....	65
6-1. Resetting of the selected control pattern .....	65
6-2. Batch resetting all of the control patterns .....	66
7. List Display and Editing of Control Patterns .....	67
7-1. List display of control patterns .....	67
7-2. Searching control pattern by name .....	68
7-3. Adjusting fabric thickness and stitch thread tightening (detailed setting screen) .....	68
7-4. Deleting control pattern .....	69
7-5. Changing control pattern name .....	70

## Manual Operation

1. Moving the Frame Back or Forward Using Stitches .....	71
1-1. Frame Back/Frame Forward by 1-stitch unit .....	72
1-2. Frame Back/Frame Forward by specifying a number of stitches .....	73
1-3. Frame Back/Frame Forward by specifying a number of color change codes .....	74
2. Thread Trimming .....	75
2-1. Operating the ATH .....	75
3. Needle Bar Related Operations .....	76
3-1. Color change .....	76
3-2. Raising or lowering the needle bar .....	77
3-3. Stopping the needle bar at the lower dead point .....	78
3-4. Raising or lowering the presser foot .....	79
4. Various Frame Movement Operations .....	80
4-1. Moving the frame to the preset optional position .....	80
4-2. Moving the frame to the previous position (manual offset) .....	81
4-3. Moving the frame to the start position .....	81
4-4. Moving the frame to the offset position .....	82
4-5. Moving the frame by entering a numeric value .....	83
4-6. Absolute origin search .....	84
4-7. Power resume .....	85
5. Other Operations .....	86
5-1. Turning ON/OFF the LED lamp .....	86
5-2. Auto lubrication system .....	87
5-3. Raising/Lowering the optional device .....	87

## Design Management

---

1. Design Input/Output .....	89
1-1. Saving designs to a USB memory .....	89
1-2. How to connect the machine to your PC .....	92
1-3. Storing designs from your PC into the machine memory .....	94
1-4. Storing designs from your PC into the machine memory using a barcode reader .....	95
2. Deleting Designs .....	96
2-1. Deleting a design from the machine memory (one design at a time) .....	96
2-2. Deleting designs from the machine memory (two or more designs at once) .....	97
2-3. Deleting designs from a USB memory .....	98
3. Changing a Design Name and a Storage Location .....	99
3-1. Changing a design name .....	99
3-2. Changing the design storage location .....	100

## Editing Needle Bar Steps and a Design

---

1. Editing Needle Bar Steps .....	101
1-1. Setting needle bar step embroidery conditions .....	101
1-2. Insertion of a needle bar step .....	105
1-3. Deletion of a needle bar step .....	105
1-4. Replacing the needle bar numbers all at one time .....	106
2. Needle Bar Management Function .....	108
2-1. Setting the needle bar thread color .....	108
3. Editing a Design .....	110
3-1. Copying a design .....	110
3-2. Dividing a design .....	111
3-3. Combining designs .....	112
4. Design Layout .....	116
4-1. Scaling up/down a design .....	116
4-2. Rotating a design .....	117
4-3. Reversing a design .....	119

5. Settings for Repetition .....	120
5-1. Repeating a design by specifying the number of repetitions .....	120
5-2. Repeating a design by automatically calculating the number of repetitions .....	122
5-3. Reversing or rotating a design alternately .....	124
6. Editing Stitches .....	126
6-1. Search by stitch No. ....	126
6-2. Search by function code .....	127
6-3. Modification of a stitch .....	129
6-4. Insertion of a stitch .....	130
6-5. Deletion of a stitch .....	132
6-6. Removal of tiny stitches .....	133

**Chapter 7**

## **Various Functions**

---

1. Offset Frame Travel .....	135
1-1. Function outline .....	135
1-2. Registering the offset position .....	137
1-3. Erasing the offset position .....	139
1-4. Moving the frame by selecting a specific stitch .....	141
1-5. Moving the frame using the color change sequence .....	142
2. Selecting Active Heads .....	144
2-1. Outline of function .....	144
2-2. Activating only the odd- or even-numbered heads .....	145
2-3. Specifying active heads for each needle bar step .....	145
3. Grouping Heads .....	149
3-1. Outline of function .....	149
3-2. Examples of making use of head groups .....	150
3-3. Grouping heads and editing needle bar steps .....	152
4. Marking .....	155
4-1. Function outline .....	155
4-2. Creating a marking design .....	156

## Maintenance

---

1. Maintenance Precautions .....	159
2. Maintenance Item List .....	160
3. Cleaning .....	161
3-1. Inside the rotary hook base .....	161
3-2. Head and its surroundings .....	163
3-3. X-axis drive system and Y-axis drive system .....	163
3-4. Controller filter .....	164
4. Lubrication .....	165
4-1. Rotary hook .....	165
4-2. Inside the head .....	166
5. Greasing .....	167
5-1. Rotary hook base gear .....	167
5-2. Inside the head .....	168
6. Inspection and Repair .....	169
6-1. Inspection of drive systems and sliding parts .....	169
6-2. Repair .....	169
7. Checking and Adjustment .....	170
7-1. Checking the needle bar lower dead point .....	170
7-2. Adjusting the thread take-up spring stroke amount .....	172
8. Others .....	174
8-1. Precautions to take when installing the tension base cover .....	174

## Troubleshooting

---

1. Message Screen .....	175
2. When the Machine Does not Stitch Well .....	181
2-1. Frequent thread breakage .....	181
2-2. Needle breaks .....	181
2-3. Poor embroidery results .....	182
3. Power Resume after Power Failure .....	183
4. Obtaining Backup Data .....	184

## Appendix

---

1. Improving Embroidery Quality (FS Mode) .....	185
1-1. Function outline .....	185
1-2. Stitch comparison .....	186
1-3. Making use of optional parts .....	187
2. Upgrading the Software Version .....	189
3. Specifications .....	193
3-1. Electrical specifications .....	193
3-2. Ambient noise level .....	193
3-3. Machine weight .....	193
4. Terminology .....	194

# Chapter 1

## Basic Machine Operation

### 1. Turning the Power ON/OFF

The power switch is located on the operation panel side of the machine.

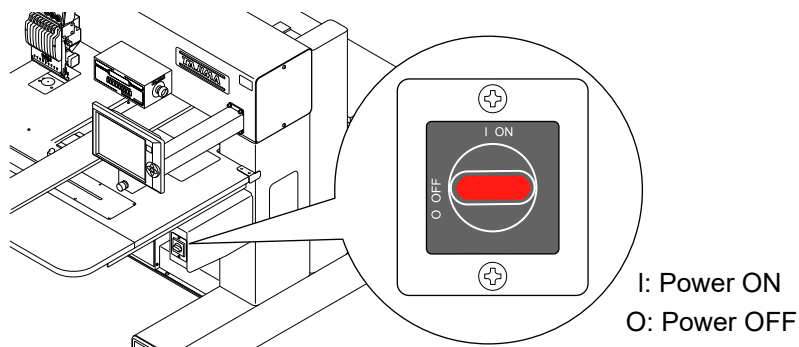

#### 1-1. Turn ON the power

##### ⚠ Caution

- ⓘ To turn ON the power again, wait for 30 seconds or more. Otherwise the system will fail to start up normally.
- ⊘ Do not turn ON the power with a USB memory inserted in the machine. Otherwise the system will fail to start up normally.

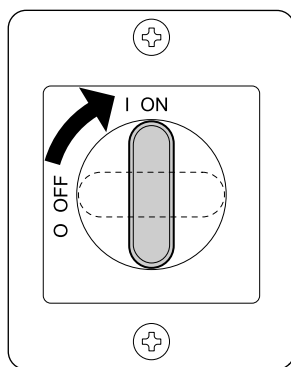

#### 1 Turn ON the power.

Once the power is turned ON, the system starts up and the software version screen appears. The tension base multi-color LEDs (left and right) are lit up light blue while the system is starting up.

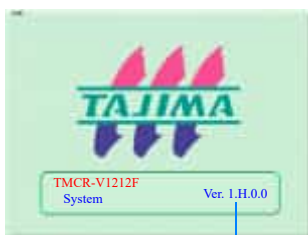

Software version

## 1. Turning the Power ON/OFF

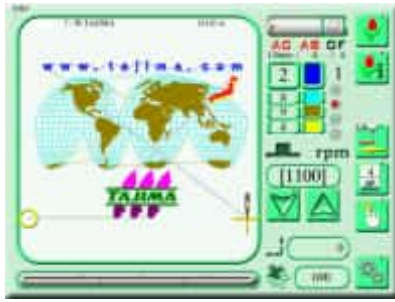

Once the system starts up, the main screen appears. In addition, the tension base multi-color LED (right) lights up green.



- The color and lighting status of the multi-color LEDs after system start-up differ depending on the status before turning OFF the power. For details, refer to "Chapter 1 3. Multi-color LEDs".

### 1-2. Turn OFF the power

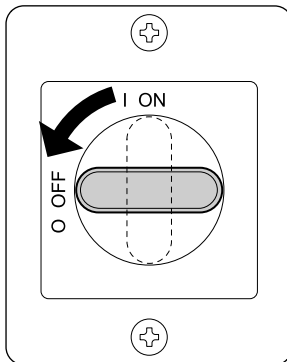

- 1 Turn OFF the power.



- Unless its emergency, do not turn OFF the power by pressing the emergency stop switch.

### 1-3. Lock the power switch

The power switch can be locked to prevent the power from being turned ON.

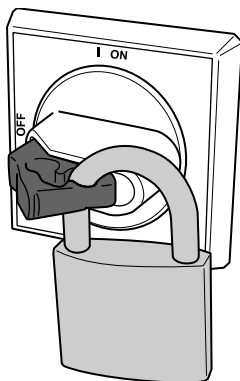

- 1 Pull out the handle.
- 2 Secure it with a padlock.



- Prepare a commercially available padlock.

## 2. Start and Stop the Machine

Start and stop the machine using the bar switch located under the table.

### 2-1. Start the machine

#### ⚠ Caution

- ! Before starting the machine, for safety, pay attention to the surrounding area. You may be injured by a moving needle bar or frame.
- ⊘ Do not use the bar switch as a grip. The machine may start unexpectedly, which may lead to injury.

#### [To start the machine immediately]

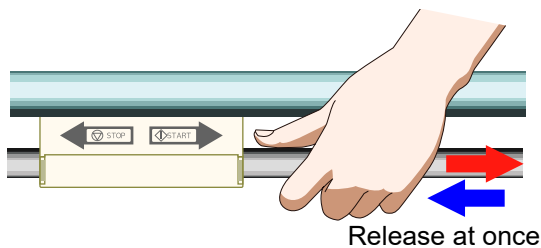

Move the bar switch to the right and release it immediately.

The needle bar moves up and down slowly (in an inching manner) and then the machine starts.



- You can configure the number of inching stitches (during startup) using a parameter. For details, refer to the separate "Parameter Settings" manual.

#### [To start the machine gradually]

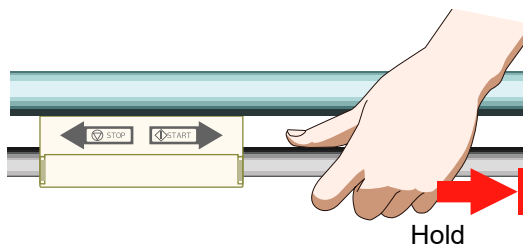

Move the bar switch to the right and hold it in that position.

While you are holding it, the needle bar moves up and down slowly (in an inching manner).



- When you release the bar switch, the machine starts normal embroidery operation.

### 2-2. Stop the machine

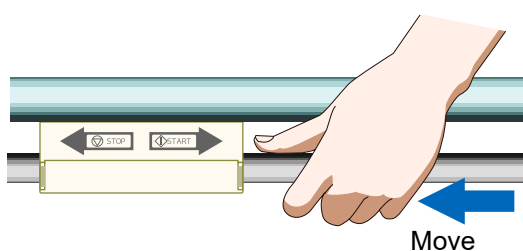

Move the bar switch to the left.

The machine stops.



- You can use the bar switch, not only to start and stop the machine, but also to move the frame along the stitches path for repair stitching at thread breakage (Frame Back/Frame Forward). For details, refer to "Chapter 4 1. Moving the Frame Back or Forward Using Stitches".

# 3. Multi-color LEDs

The tension base multi-color LEDs light up or blink in a particular color to indicate the machine operation status or the occurrence of thread breakage.

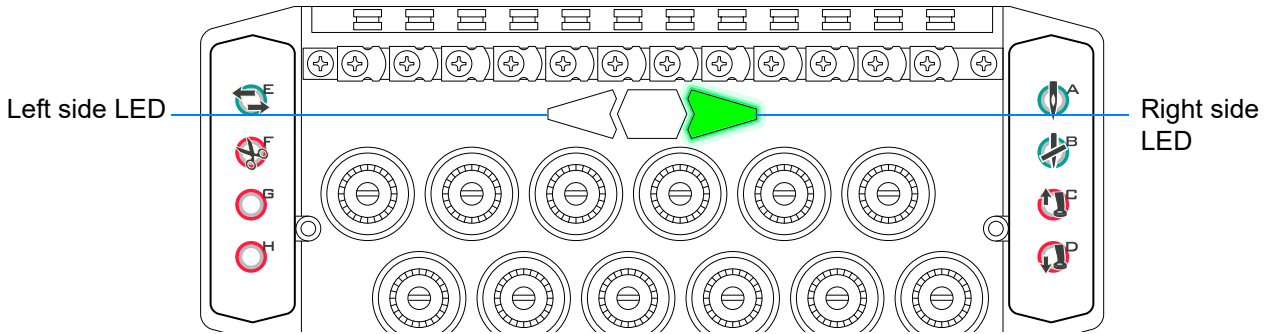





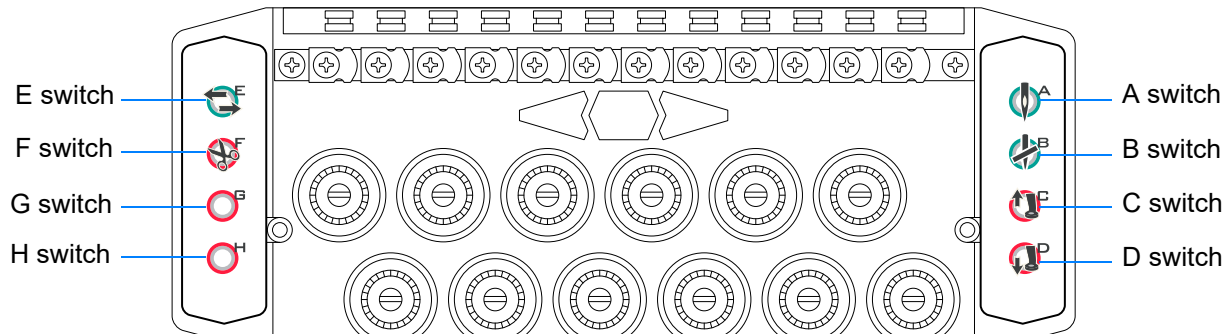

LED	Color	Condition
Right/left	Lit in light blue 	Both LEDs are lit during start-up until the main screen appears.
	Unlit 	Both LEDs will be off when the head is suspended.
Right side	Lit in green 	Lit when embroidery is available or in progress.
	Blinking in green 	Indicates that the frame is moving back (along the stitches) and that the head is one without thread breakage.
	Lit in red 	Lights up if the upper thread is broken.
	Blinking in red 	Blinks if the under thread is broken.
	Lit in orange 	Lights up if the start method of sewing after Frame Back is set to "return stitching" and "repair stitching".* 1
Left side	Lit in blue 	If you stop the machine during embroidery and manually move the frame, this LED lights up. It does so to indicate that the frame is not at the original position (i.e., the position where it was when you stopped the machine).

\*1: To change the start method of sewing after Frame Back, use the A switch on the tension base. For details, refer to "Chapter 1 4. Direct Command Switch".

## 4. Direct Command Switch

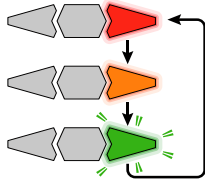



The following functions are assigned to the direct command switches on the left and right sides of the tension base.



Switch	Function
<p>A switch</p> 	<p>Changes the head to "active".</p> <p>The multi-color LED lighting color switches as follows every time you press the A switch after you have performed Frame Back due to thread breakage.* 1</p>  <p>Red: The machine performs repair stitching.</p> <p>Orange: The machine performs return stitching and repair stitching.</p> <p>Blinking green: The machine does not perform repair stitching.</p>
<p>B switch</p> 	<p>Changes the head to "suspended".</p> <p>If the head is suspended, the multi-color LEDs go off and the needle bar will not move up/down when you start the machine.</p>
<p>C switch</p> 	<p>Press this switch to raise the presser foot.</p>
<p>D switch</p> 	<p>Press this switch once to lower the presser foot to the F.B. lower dead point. Press it again to lower the presser foot to the lower dead point.</p>
<p>E switch</p> 	<p>Toggles between Frame Back and Frame Forward.</p>

\*1: Even when you are not performing Frame Back, the multi-color LED lighting color changes every time you press the A switch.

4. Direct Command Switch

Switch	Function
<p>F switch</p> 	<p>Press this switch (for 1 second) to trim the upper and under threads.</p>
<p>G switch</p>  <p>H switch</p> 	<p>Parameter settings allow you to assign any of the functions below to the G and H switches respectively.</p>  <div style="background-color: #e0ffe0; padding: 10px;"> <ul style="list-style-type: none"> <li>• For functions involving movement, hold down the G switch or the H switch (for 1 second). Release the switch when the warning buzzer sounds. The selected function will be executed.</li> <li>• This function can be operated only when the machine is stopped at the main shaft fixed position and the main screen is displayed.</li> <li>• When the LED on the tension base is off, this function does not work.</li> </ul> </div> <ul style="list-style-type: none"> <li>• Presser foot Up at tracing (High)</li> <li>• Presser foot Up at tracing (Low)</li> <li>• Offset return</li> <li>• Manual offset</li> <li>• Frame travel to optional position</li> <li>• Start position return</li> <li>• 1 stitch dropping <sup>*1</sup></li> <li>• Needle bar Up</li> <li>• Stop at lower dead point <sup>*2</sup></li> <li>• Under thread trimming ATH</li> <li>• Needle bar lowering all at once</li> <li>• Reset of Preset Halt by Stitches</li> <li>• Reset of Preset Halt by Data</li> <li>• Reset of Preset Halt by Designs</li> <li>• Light ON/OFF</li> <li>• ATH at repair stitches (ON/OFF)</li> </ul>

\*1. When the G or H switch is pressed and held, the needle bar will drop one stitch.  
 If the multi-color LED (right side) is blinking green, "1 stitch dropping" cannot be performed.

\*2. When raising the needle bar, use the operation panel.

## 5. Screen Operations

Use the operation panel to perform operations for embroidery and configure various settings.

The touch panel allows you to switch the display screen and configure various settings by lightly touching the icons displayed on the screen.

### ⚠ Caution

- ! Touch them with your finger.
- ⊘ Do not strongly press or poke the touch panel with something sharp. Doing so may damage the panel.

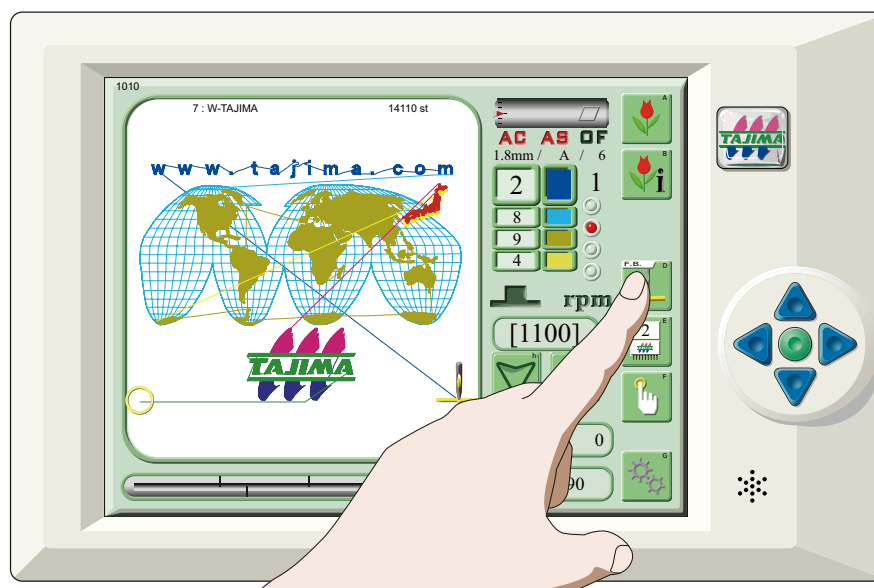

## 5-1. Changing the display background color

When the design color and the background color are the same, making the design image difficult to see, you can change the background color.

By continuously pressing the screen, the background of the display will change in the following order: white → black → red → green → blue → yellow → white.

### ■ Screen color rotation

#### Main screen

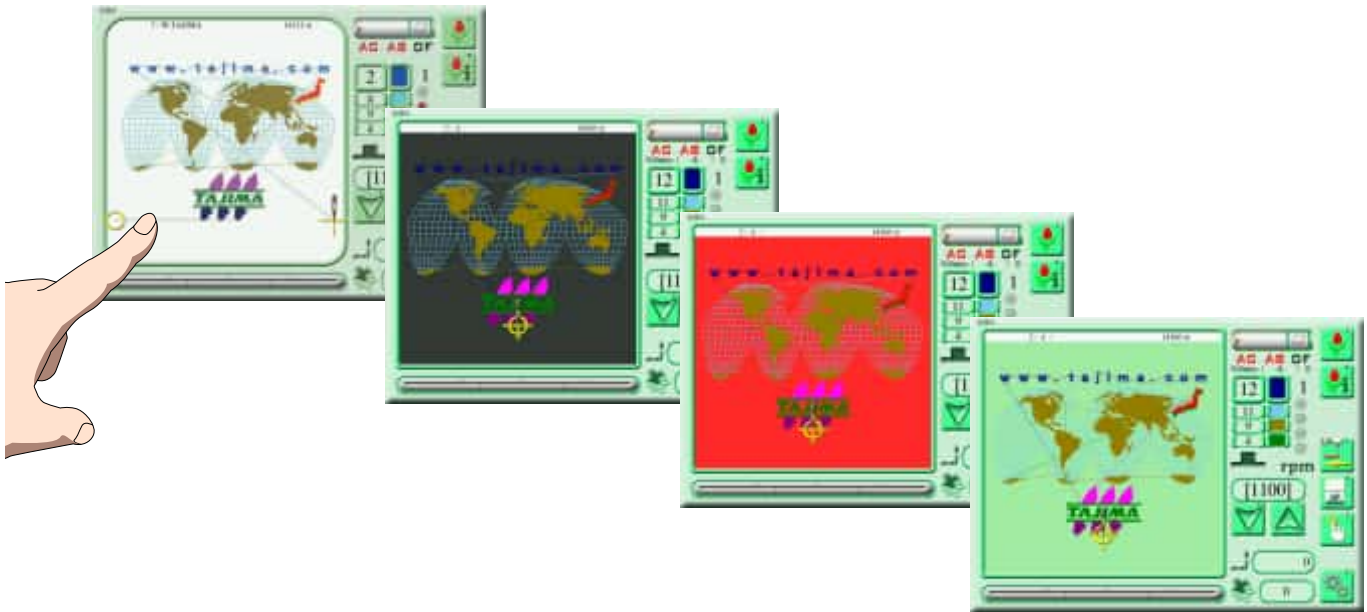

In addition to the main screen, the following screens can also be changed:

- Design confirmation screen, frame back/forward screen, manual color change screen, manual operation screen, needle bar setting screen, per step setting screen

#### Example:

Design confirmation screen

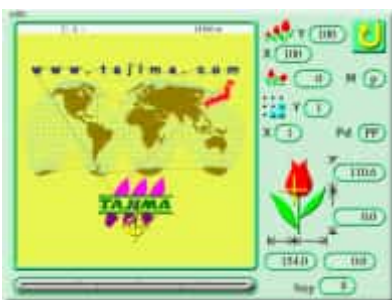

Needle bar selection screen

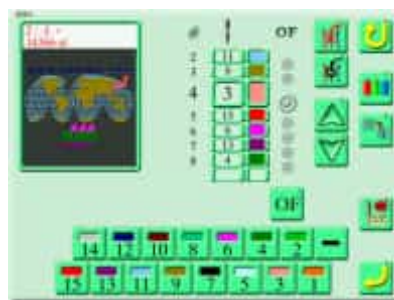







Per step setting screen

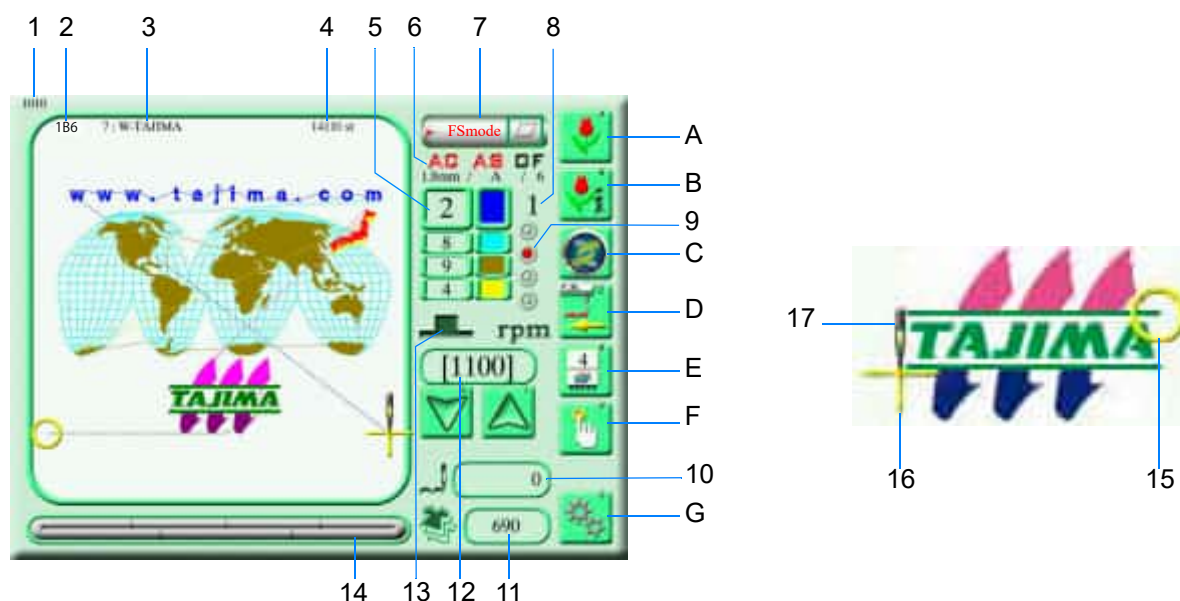

## 5-2. Main screen

The main screen appears once you turn ON the power and the system successfully starts up. You can begin to configure various settings and operate the machine from the main screen.



No.	Description	No.	Description	
1	Screen number	14	Embroidery progress (indicated by red scale marks)	
2	Stop factor (displayed during stops of the machine)	15	Embroidery end point	
3	Design name	16	Embroidery start point	
4	Total number of stitches of design	17	Current embroidery position	
5	Needle bar No. of the current step	A	Navigate to the design selection screen	
6	AC (Auto Color Change), AS (Auto Start), and OF (Automatic Offset) setting status (displayed in red if the setting is enabled)	B	Navigate to the detailed information screen of design	
7	FS mode setting status ("FS mode" is displayed if enabled)	C	i-TM mode display (when equipped with optional i-TM)	
8	Current needle bar step No.		 : Auto mode	
9	Setting status of offsetting at automatic color change (displayed in red if enabled)		 : Manual mode Navigate to the detailed information screen of design while in manual mode. Hold down the icon to switch modes.	
10	Current number of stitches	D	Navigate to the current FB (Frame Back)/FF (Frame Forward) setting condition and FB/FF screens	
11	Cumulative embroidery count (even if the power is turned OFF/ON, counting will continue.)			
12	High-speed R.P.M.	E	Navigate to the manual color change screen (the displayed number is the current needle bar No.)	
13	Current main shaft angle  Fixed position		F	Navigate to the manual operation screen
	 "Main shaft brake" is set to "No".  Outside of fixed position range		G	Navigate to the parameter setting screen

### 5-3. Design selection screen

This screen lets you save, select, or edit your design.

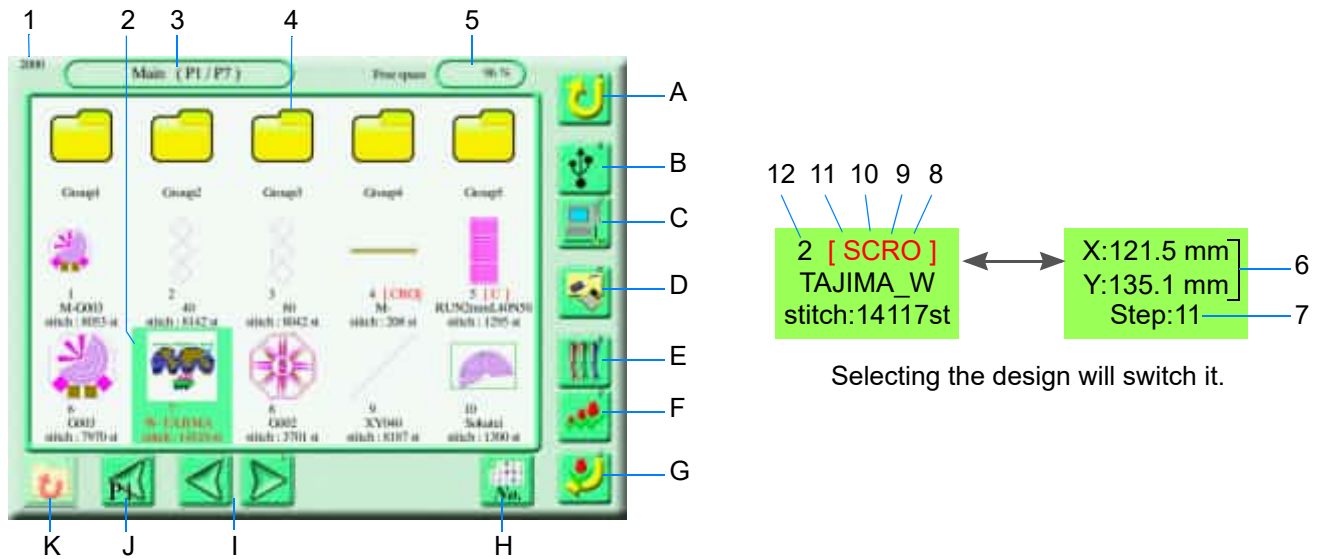

Selecting the design will switch it.

No.	Description	No.	Description
1	Screen number	A	Back (return to the previous screen)
2	Design stored in the machine memory	B	Navigate to the USB memory screen
3	Folder and screen page	C	Navigate to the design screen registered in DG by Pulse
4	Design storage folder (You cannot change the folder names "Group1" to "Group5")	D	Navigate to the design edit screen
5	Machine memory capacity (40,000,000 stitches) (Free space percentage (%) is displayed. The remaining number of stitches is displayed if the free space is less than 20%.)	E	Navigate to the needle bar selection screen
6	Design size	F	Navigate to the design enlargement/reduction and repeat screens
7	Number of needle bar steps	G	Save Changes (navigate to the data set screen)
8	With setting of automatic offset	H	Rearrangement of designs (Designs are reordered every time you touch the icon.) • No.: In the ascending order of machine memory numbers • Name: Design name alphabetical order • Time: Uploading order
9	With setting of repeat		
10	With setting of scaling up/down and rotate of design	I	Navigate to the previous or next page
11	Indicates that the embroidery condition for the needle bar step has been changed	J	Back (return to the first page)
12	Machine memory No. (When you store a design in the machine memory, machine memory numbers are assigned in the order saved)	K	Back (return to the "Main" folder screen if the "Group" folder is selected)



- Icon C is not displayed if a LAN cable is not connected.
- When there is no design in the machine memory, icons D, E, and F are not displayed.

## 5-4. Description of basic icons

There are common icons you can use to switch the display screen, save settings, or enter alphanumeric characters.

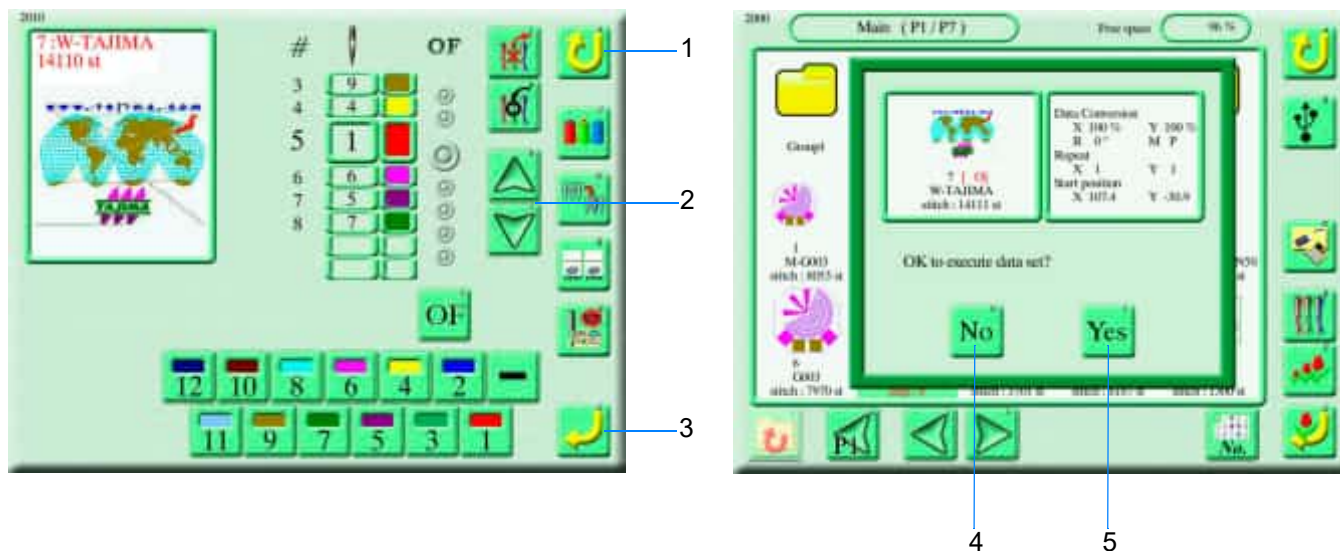

### Common icons

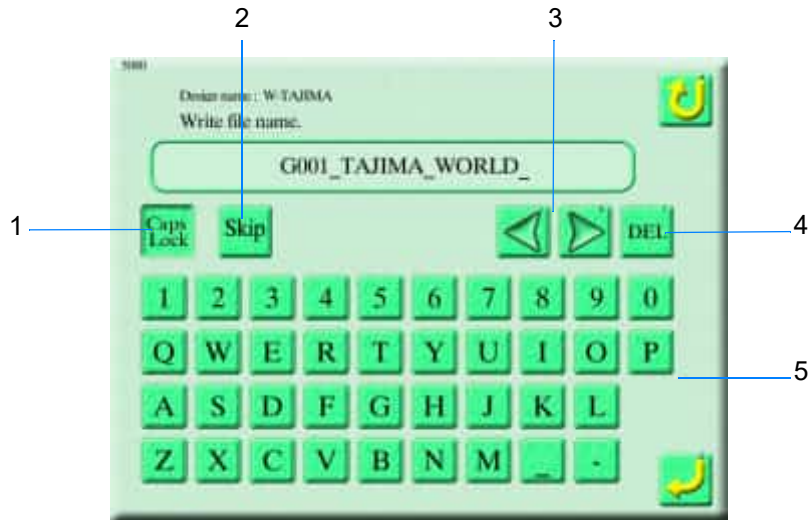

No.	Description
1	The screen will return to the previous screen by one.
2	Increase/decrease the value or scroll up/down the screen up/down.
3	Put the setting into effect.
4	Cancel the operation and disable the setting.
5	Save or enable the setting.

**■ Entering alphanumeric characters**



No.	Description
1	Toggle between uppercase and lowercase.
2	<p> : If there is a design with the same name in the USB memory, it will be overwritten and saved.</p> <p> : If there is a design with the same name in the USB memory, the new design will be saved under the file name appended with (1) at the end.</p>
3	Move the cursor.
4	Delete the character at the cursor position.
5	Enter a character by pressing the corresponding icon.

## 6. Frame Travel

To manually move the frame, use the frame travel keys on the operation panel.

To change the frame travel speed, use the speed switching key.

### 6-1. How to move the frame

While you are holding down one of the frame travel keys, the frame keeps moving in that direction.

#### **⚠ Caution**

- Do not put your hand on the table or bring your hand close to the frame. Doing so may cause your finger or hand to be injured when the frame moves.

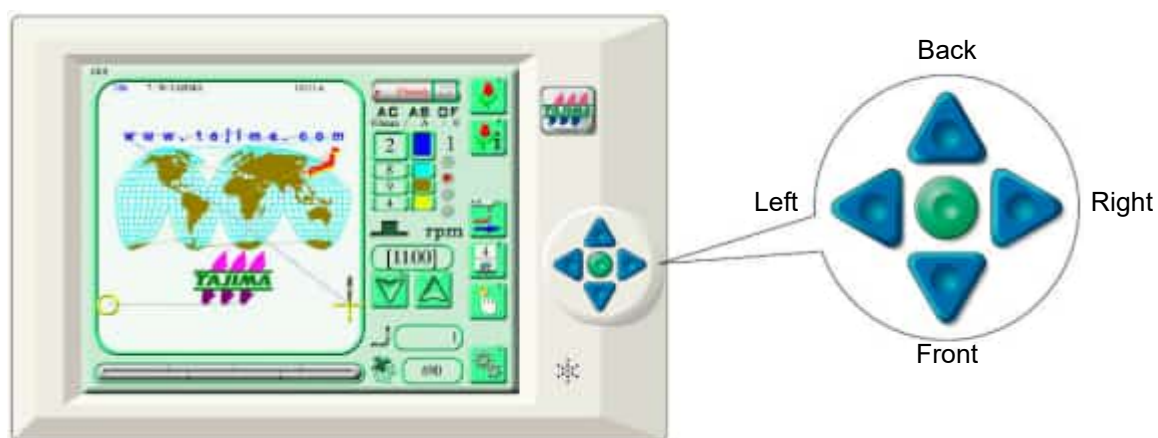

- The machine stops and a message screen appears when the frame reaches edge of the embroidery space. Cancel the stop code and correct the embroidery position.
- If you have moved the frame by hand with the power OFF, turn ON the power and perform power resume. For details about power resume, refer to "Chapter 4 4-7. Power resume".

## 6-2. Changing the travel speed

You can toggle between the low and middle frame travel speeds by pressing the speed switching key. You can also move the frame at high speed by pressing one of the frame travel keys while holding down the speed switching key.

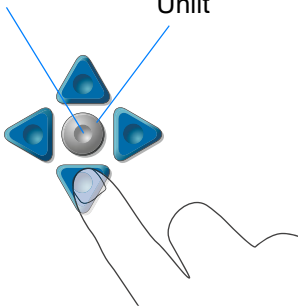
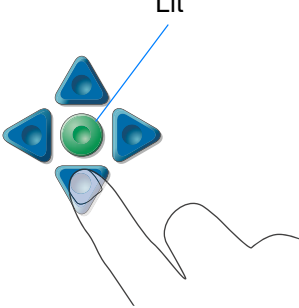
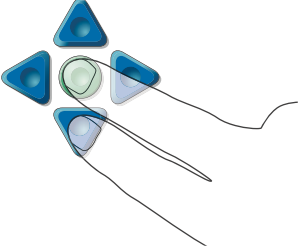
Low speed	Middle speed	High speed
<p>Press the speed switching key to turn off its back light, then press one of the frame travel keys.</p> <p>Speed switching key      Unlit</p> 	<p>Press the speed switching key to turn on its back light, then press one of the frame travel keys.</p> <p>Lit</p> 	<p>Press one of the frame travel keys while holding down the speed switching key.</p> 

### 6-3. Checking the frame position (coordinates)

You can check the current frame position (coordinates) on the manual operation screen.



- To display the manual operation screen, press  on the main screen.

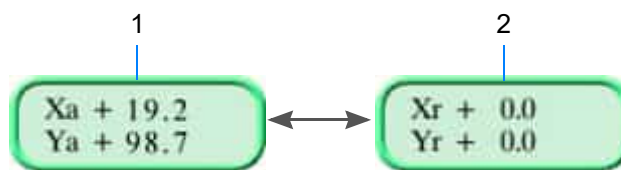
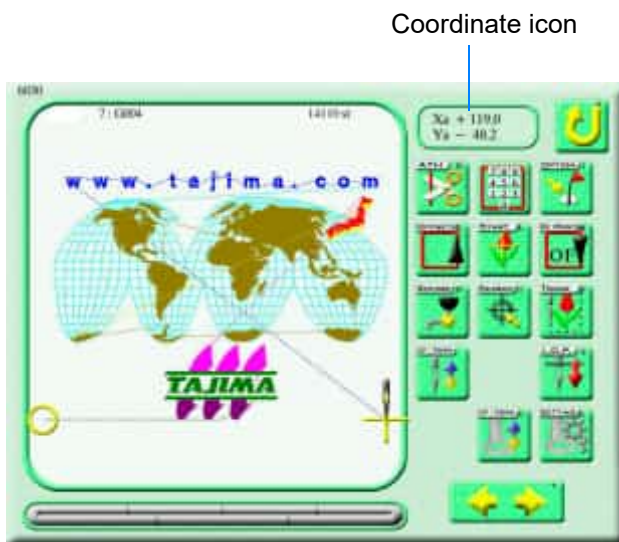

Pressing the coordinate icon will change the indication.

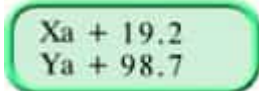
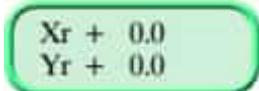
No.	Coordinate icon	Description
1		The coordinates based on the absolute origin of the frame appear.
2		The coordinates based on the start position of the design whose data is set appear.



- If the coordinates are not correctly displayed, the absolute origin may not be correctly set. Execute absolute origin search. For more information on absolute origin search, refer to "Chapter 4 4-6. Absolute origin search".







## 7. Data Input/Output

The USB port is located on the right side of the operation panel, and the LAN port is located on the operation panel side of the machine.

### 7-1. Connecting a USB memory

Insert a USB memory into the USB port of the operation panel. You can use a USB memory to input/output designs and upgrade the software version.

#### Caution

-  Do not turn ON the machine power with a USB memory inserted into the operation panel. Otherwise the system will fail to start up normally.
-  Do not insert a USB memory if it contains dirt or dust into the connector.
-  Do not insert or remove a USB memory while the machine is running.
-  Do not forcibly insert a USB memory.
-  Insert a USB memory slowly.
-  Insert a USB memory straight into the USB port. Diagonally inserting a USB memory may cause the connector to interfere with and possibly destroy the internal circuit board.
-  Do not attempt to use a USB memory until at least five seconds elapse after you insert it.

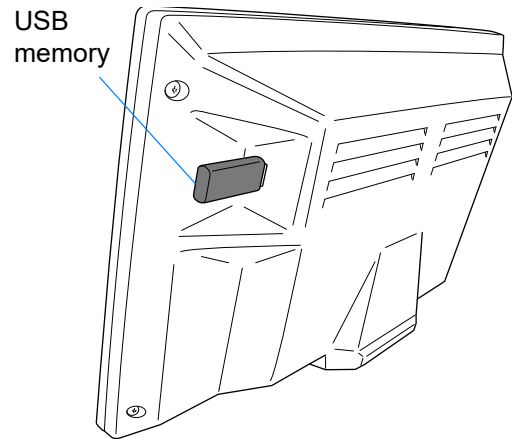

- The machine does not work with USB memories of certain types and capacities.
- Use a recommended USB memory (i.e., a USB 2.0-compliant USB memory formatted in the FAT/FAT32 format).

## 7-2. Connecting a LAN cable

Connect a LAN cable to the LAN port on the operation panel side of the machine. Use the LAN cable to connect the machine to your PC via LAN.

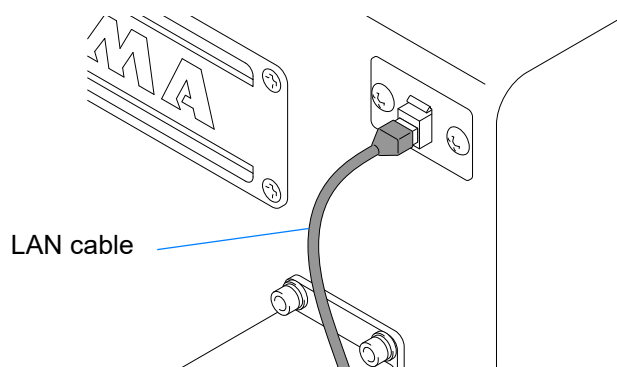

- To connect the machine via a router to your PC, use an aftermarket straight cable.
- To directly connect the machine to your PC, use a cross cable available on the market.
- For more information on connecting the machine to your PC, refer to "Chapter 5 1-2. How to connect the machine to your PC".

1

2

3

4

5

6

7

8

9

10

# 8. Table Offset Switch (Some Models)

A table offset switch may be equipped under the table, depending on the machine model. When the table offset switch is operated while the machine is stopped, it allows you to move the frame from its stopping position to a preset position (table offset position). Use this feature when the frame obstructs threading and similar tasks.

- You can configure the table offset position using a parameter. For details, refer to the separate "Parameter Settings" manual.
- The start and stop switches on the switch box can also be used for the regular machine start and stop operations.
- If the frame does not move to the table offset position, the absolute origin may be misaligned. Execute absolute origin search. For more information on absolute origin search, refer to "Chapter 4 4-6. Absolute origin search".

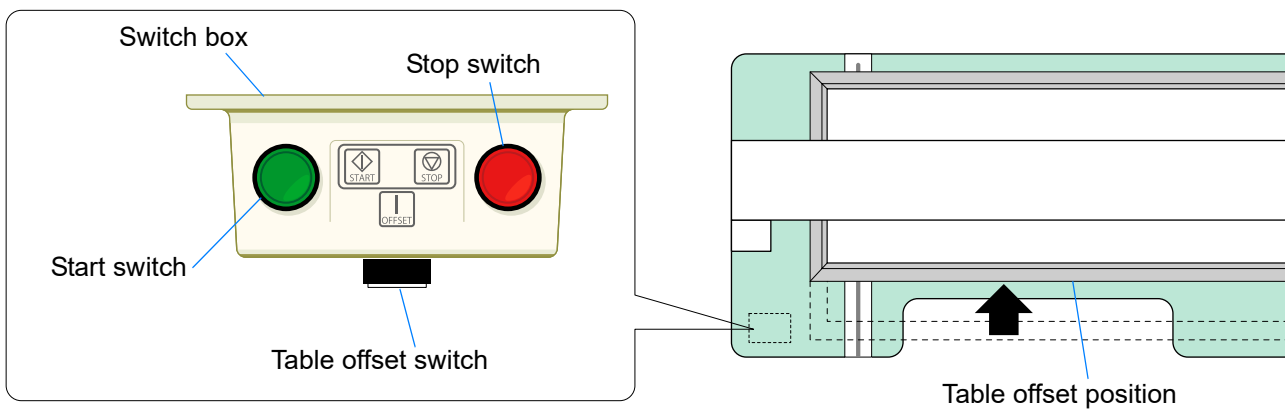

## 8-1. Move the frame to the table offset position.

The way to press the table offset switch differs depending on whether or not you perform thread trimming.

### ⚠ Caution

Do not put your hands on the table when you operate the machine. Doing so may cause your finger or hand to be injured when the frame or needle moves.

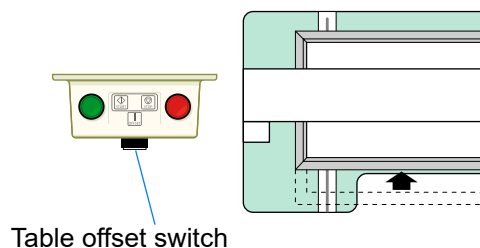



Moving method	Switch operation
When moving the frame immediately	Press and release immediately
When moving the frame after cutting the thread	Press and hold for at least two seconds.

## 8-2. Return the frame to the previous position.

The switch operation differs depending on the frame return method.

### Caution

-  Do not put your hands on the table when you operate the machine. Doing so may cause your finger or hand to be injured when the frame moves.
-  Do not use the bar switch. You may be injured by a moving needle bar or frame.

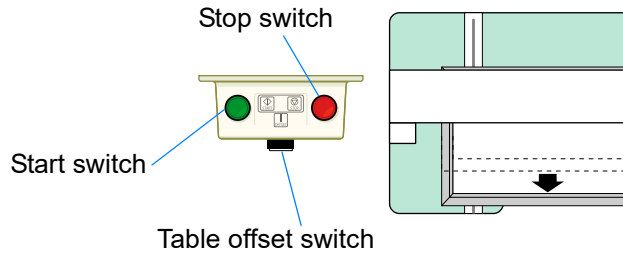

Frame return method	Switch	Switch operation
When returning the frame to the previous position	Table offset switch	Press and release immediately
When resuming embroidery immediately after returning the frame to the previous position <sup>*1</sup>	Start switch	Press and release immediately
When performing a frame-back by one stitch after returning the frame to the previous position (Each press returns the frame by one stitch) To perform a continuous frame-back, hold the switch to keep moving the frame back.	Stop switch	Press and release immediately

\*1. Resuming embroidery immediately after returning the frame to the previous position is only possible if the "Return the frame after manual frame travel" parameter is set to "Yes". For details, refer to the separate "Parameter Setting" manual.

# Chapter 2

## How to Embroider

### 1. Basic Flow of Embroidery

For details, refer to the corresponding guides and chapters.

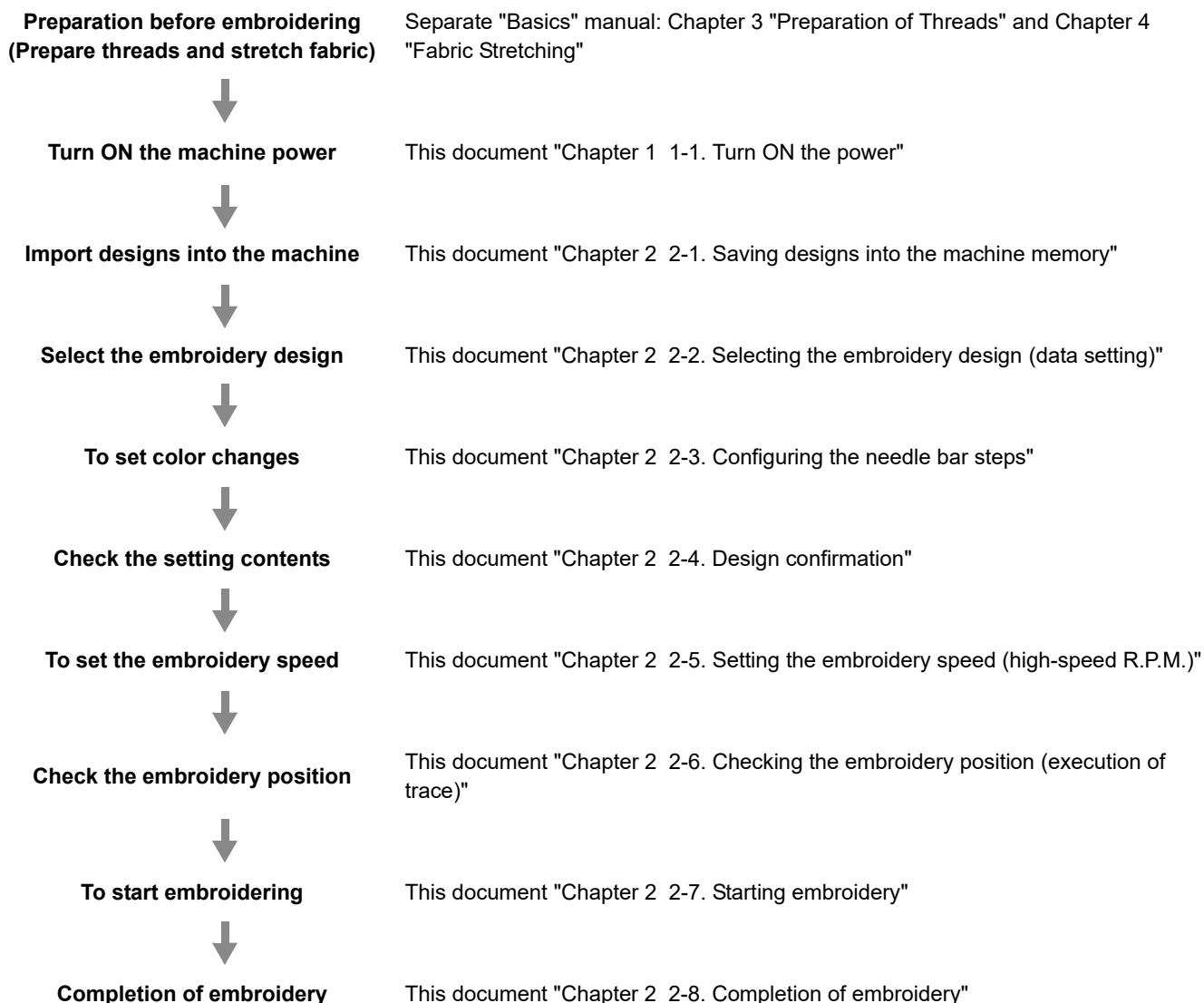

## 2. Embroidery Procedures

This section describes the procedures for importing the desired designs into the machine memory and starting and completing embroidery.

### 2-1. Saving designs into the machine memory

Save the embroidery design in the machine memory using one of the following methods:

- A USB memory
- Your PC
- A bar code reader

The following example shows how to select two designs from a USB memory and store them in the "Main" folder in the machine memory.



- The "Main" folder can store up to 200 designs and the folders from "Group1" to "Group5" can each store up to 90 designs (thus up to 650 designs in all). The maximum number of designs you can store may, however, be smaller than mentioned above depending on the free space of the machine memory.
- The start position for designs that have been embroidered is saved as condition data in the corresponding design data.
- The machine memory can store designs using your PC and bar code reader as well. For details, refer to "Chapter 5 1-3. Storing designs from your PC into the machine memory".



1 Insert a USB memory containing designs into the USB port on the operation panel.

2 Press  on the main screen.



3 Press .

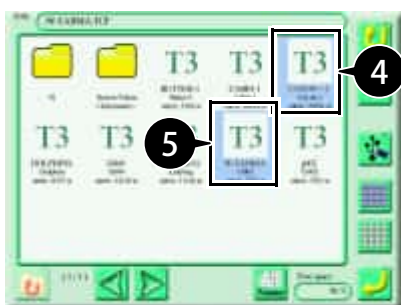

4 Select the first desired design.



• Press  to select all of the designs.

• Press  to deselect all of the designs.

5 Select the second desired design.



6 Press  .



- If the maximum number of designs you can store is exceeded or the machine memory is short of free space, error No. 2BA appears.

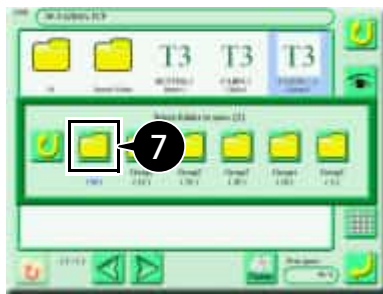

7 Press  "Main".

The selected designs are stored into the machine memory.

### ■ About the display of a design

If there is no design data in the USB memory, the following is displayed:

If there is design data, a thumbnail is displayed.

 ← Saving format of design  
 G0003 ← File name (indicated on your PC)  
 MADELENE ← Design name  
 stitch:30034st ← Number of stitches in design

Saving format of design

- T: TAJIMA format (DST)
- T2: TAJIMA binary format (TBF)
- T3: TAJIMA integrated file (TCF)

Depending on the saving format of the design, the designs will not be displayed like the ones above.

## 2-2. Selecting the embroidery design (data setting)

Select the embroidery design so that the machine can start embroidery.

### ⚠ Caution

- ⊘ Do not put your hands on the table when you operate the machine. Doing so may cause your finger or hand to be injured when the frame moves.

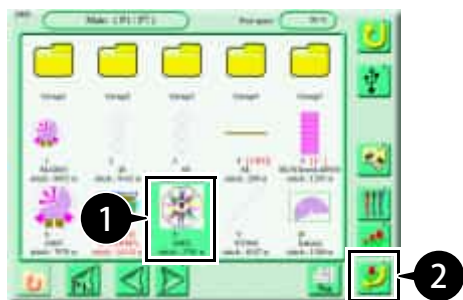

1 Select the embroidery design on the design selection screen.

2 Press  .





3 Press  .

The design data is set.

### [If the design contains start and offset positions]

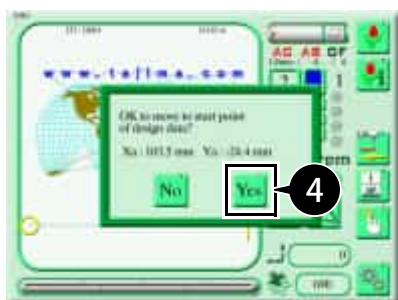
If the design contains a "start position" (i.e., the previous embroidery start position of the selected design) and "offset position", the frame travel message screen appears after the data is set.



4 Press  .

The frame moves to the start position or the offset position.

If you select "No", the current frame position will be the design start position.



- For more information on Automatic Offset settings, refer to "Chapter 7 1-2. Registering the offset position".

**[If the design contains a message]**

If the design contains a message created with DG by Pulse (optional design creation software), the message will appear after you set the data and upon completion of embroidery. For more information, refer to the user's manual for DG by Pulse.

Example: After you set the data

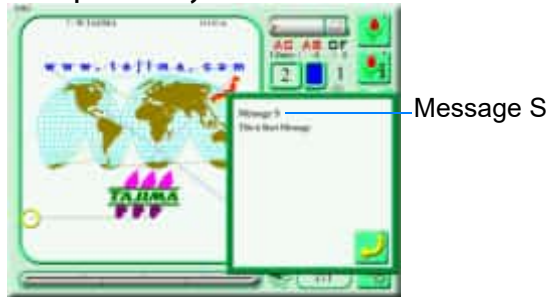

- Writing a message into the design data (\*\*\*\*.TCF) requires DG15 by Pulse or later.

## 2-3. Configuring the needle bar steps

Set a needle bar to use (sewing order) for each needle (Up to 999 steps) bar step of the selected design.

The machine performs embroidery while automatically changing the color based on those settings.

The following example shows how to assign needle bar No. 4 to needle bar step 1 and needle bar No. 6 to needle bar step 2.



- If the "Auto Color Change" parameter is set to "No", the machine will not automatically change the color. For details, refer to the separate "Parameter Settings" manual.
- This procedure is not required when a needle bar step setting is included as the condition data in the design.



1 Select the desired design on the design selection screen.

2 Press .

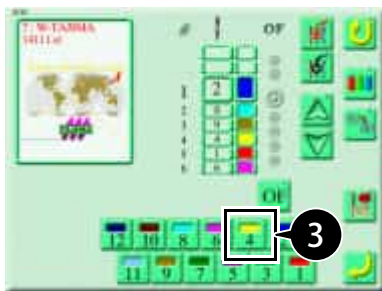

3 Press .

Needle bar No. 4 is assigned to needle bar step 1 and the screen proceeds to the next needle bar step.



- To select an arbitrary needle bar step,

press  .

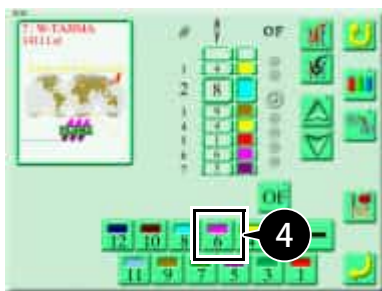





4 Press .

Needle bar No. 6 is assigned to needle bar step 2 and the screen proceeds to the next needle bar step.



- The selection of needle bar step 2 or later will display

. Pressing  for needle bar step 3 will display    and repeat needle bar steps 1 and 2 only.

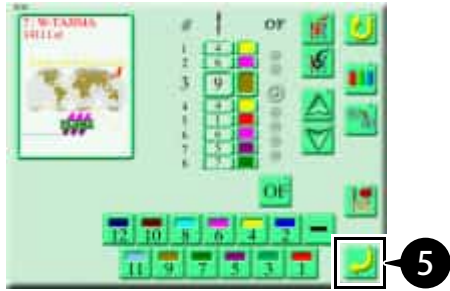

5 Press  .

Now you are done configuring the needle bar steps.

### 2-4. Design confirmation

You can check settings such as the size and orientation of the design whose data is set.



1 Press  .

2 To check the settings, use the following confirmation screen.

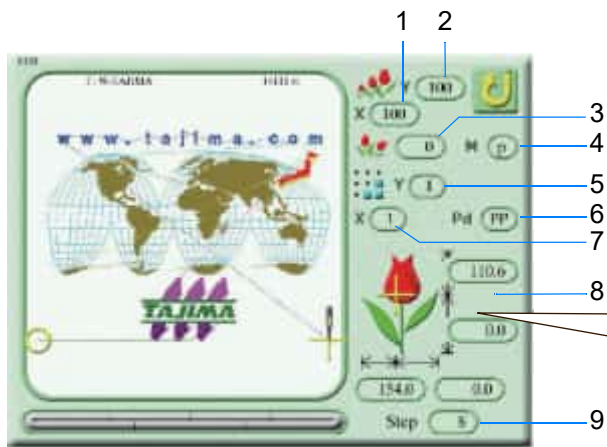

Example of display:

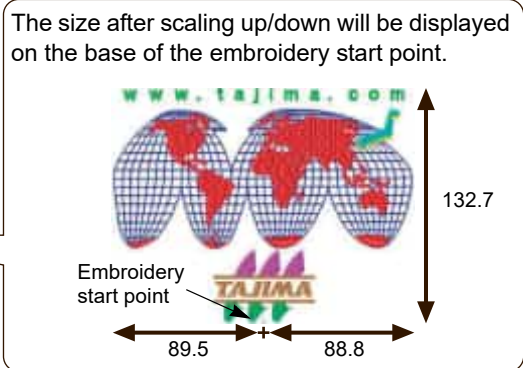

No.	Description	No.	Description
1	Scale ratio of design (Horizontal)	6	Design repetition pattern
2	Scale ratio of design (Vertical)	7	Number of design repeats (Horizontal)
3	Rotation angle of design	8	Size of design (mm)
4	Design reversal (p = normal, q = reversed)	9	Number of needle bar steps of design
5	Number of design repeats (Vertical)		



• For more information on the settings, refer to "Chapter 6 4. Design Layout".

## 2-5. Setting the embroidery speed (high-speed R.P.M.)

You can set the maximum embroidery speed (high-speed R.P.M.).

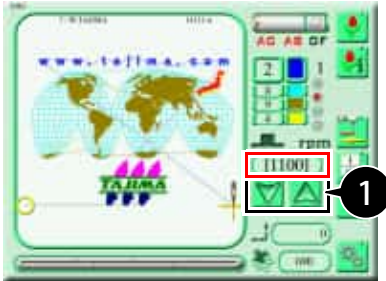

During operation, the embroidery speed changes according to the stitch length of the design without exceeding the configured limit.



1 Press   to set the R.P.M. limit.

The new setting appears in the red box.



- Hold   down to change the value continuously.
- You can also configure the setting during embroidery operation.

## 2-6. Checking the embroidery position (execution of trace)

Before starting embroidery, you can move the frame along the contour of the design without running the machine (referred to as "tracing") to check if the embroidery position (start position) is correct and make sure the design fits the frame or space to be used.

### Outline of trace

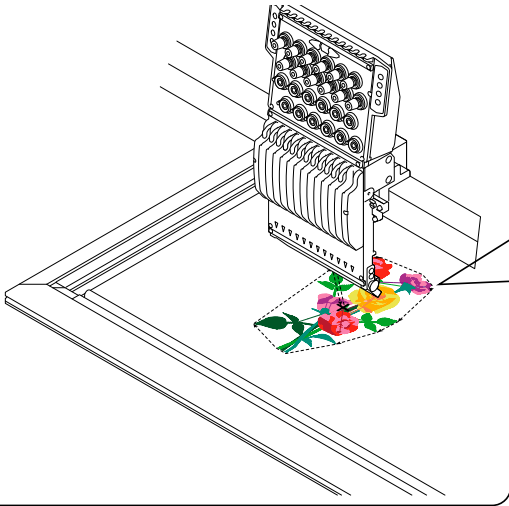

Tracing starts at the start position and proceeds along the contour of the design.

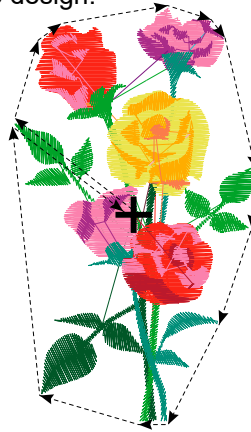

⊕ : Start position

[If Automatic Offset setting is enabled for the frame]

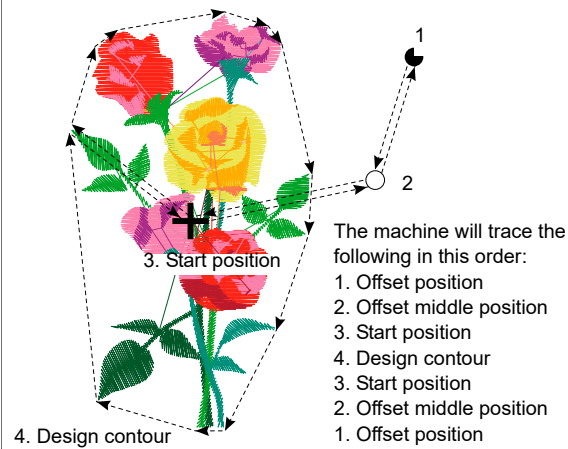

[If the repetition setting is enabled for the design]

The machine will trace all designs as a whole after tracing the first design.

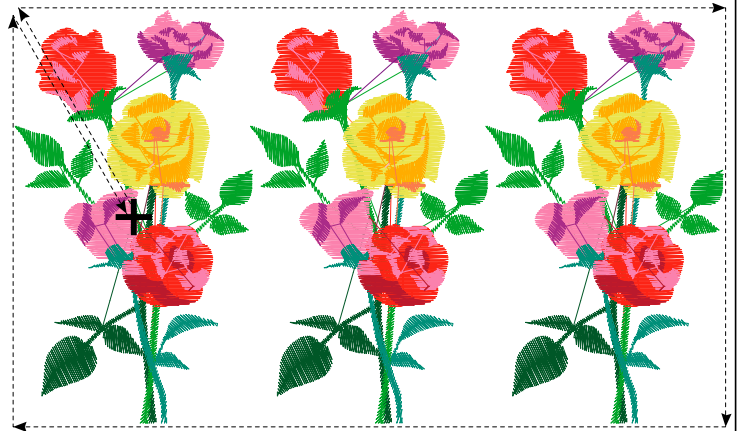

- For more information on Automatic Offset settings, refer to "Chapter 7 1-2. Registering the offset position".
- For more information on repetition settings, refer to "Chapter 6 5. Settings for Repetition".
- If the start position is not correct, the frame stops during tracing and error No.225 appears. Correct the start position and perform tracing again.

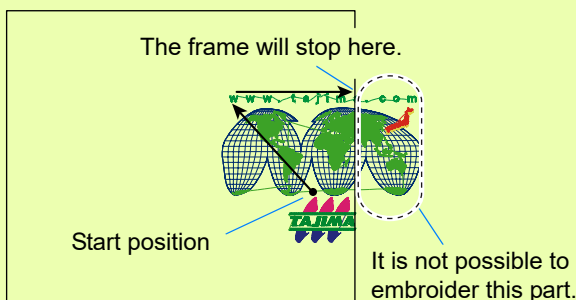

**How to operate**

**Caution**

Do not put your hands on the table when you operate the machine. Doing so may cause your finger or hand to be injured when the frame moves.

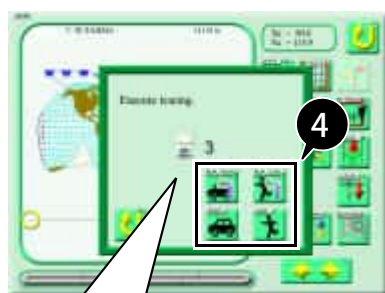
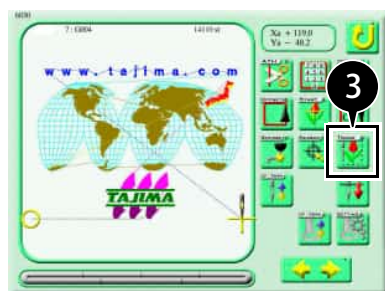
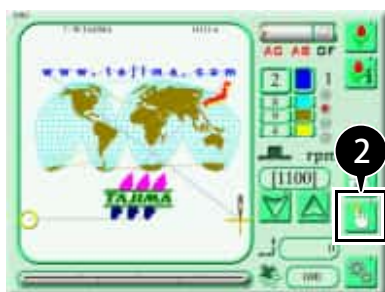
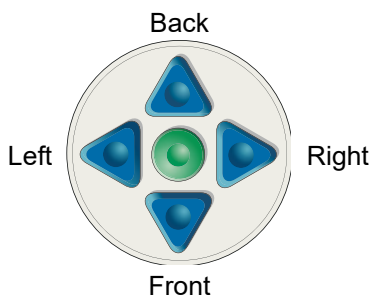

**3** Current needle bar No.

**1** Using the frame travel key, move the frame to the start position.



For more information on moving the frame, refer to "Chapter 1 6-1. How to move the frame".

**2** Press  on the main screen.

**3** Press .

**4** Execute trace.



: High-speed trace after raising the presser foot



: Low-speed trace after raising the presser foot



- The position where tracing was executed is stored as the start position.
- To suspend tracing, stop the machine. To resume tracing, follow instructions on the screen.

Icons are added if "Presser foot Up at tracing" is set to "No" in the parameters.



: High-speed trace without changing presser foot height



: Low-speed trace without changing presser foot height

## 2-7. Starting embroidery

### ⚠ Caution

! Before starting embroidery, for safety, pay attention to the surrounding area. You may be injured by a moving needle bar or frame.

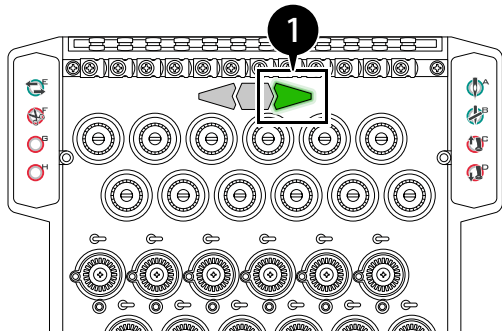

1 Check that the multi-color LED (on the right side) of the embroidery head is lit in green.



- If it is not lit, press the A switch on the tension base.

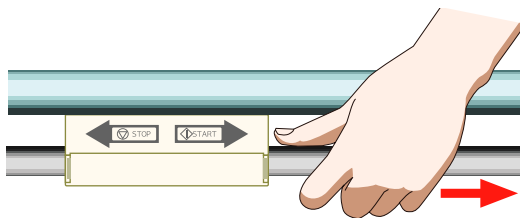

2 Move the bar switch to the right.

The needle bar moves up and down slowly (in an inching manner) and then embroidery starts.



- For more information on operating the bar switch, refer to "Chapter 1 2-1. Start the machine".

### ■ Checking the embroidery progress

The embroidery progress is indicated by red scale marks in the lower part of the main screen.

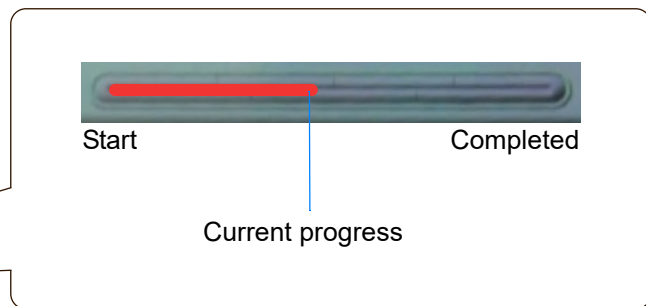
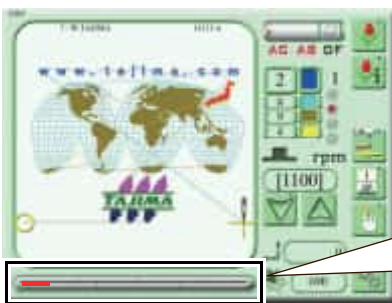

### ■ How to resume embroidery after moving the frame

After you manually move the frame during embroidery, you can resume embroidery by one of the following methods:

- Return the frame to the previous position using manual offset operations and then resume embroidery using the bar switch.
- Move the bar switch to the right. The frame returns to the previous position, and the operation resumes automatically. (This method is only available if the "Return the frame after manual frame travel" parameter is set to "Yes".)



- For more information on manual offset, refer to "Chapter 4 4-2. Moving the frame to the previous position (manual offset)".
- If the "Return the frame after manual frame travel" parameter is set to "No", the frame does not return to the previous position and embroidery resumes from the position the frame was moved to. The parameter is set to "No" by factory default. For details, refer to the separate "Parameter Settings" manual.

## 2-8. Completion of embroidery

Upon completion of embroidery, the frame moves to the start position and the machine stops.

### Caution

-  Do not put your hands on the table after embroidery is completed. Doing so may cause your finger or hand to be injured when the frame moves.



- If the "Automatic origin return" parameter is set to "Yes", the frame moves to the design start position upon completion of embroidery. If it is set to "No", the frame stops at the position where embroidery is completed. For details, refer to the separate "Parameter Settings" manual.

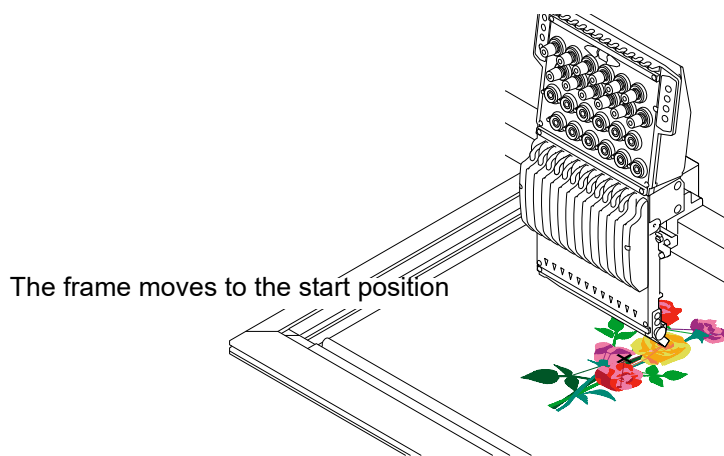

### [If Automatic Offset setting is enabled for the frame]

Upon completion of embroidery, the frame moves to the offset position and the machine stops.



- For more information on Automatic Offset settings, refer to "Chapter 7 1-2. Registering the offset position".

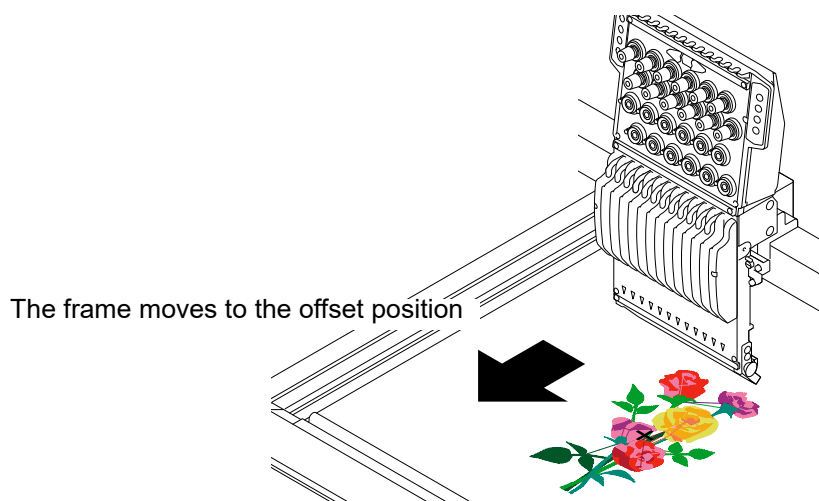

# 3. Making Use of the DCP

The Digitally Controlled Presser Foot (DCP) is a system that uses a motor and digitally controls the presser foot to press the fabric.

It is possible to set the height and stroke of the presser foot according to the type and thickness of the fabric, which reduces the fluttering of the fabric and achieves more stable stitching.

In addition, by using the touch panel, the DCP allows ease of presser foot adjustments, which operators previously needed to make manually.

## 3-1. Presser foot setting items

Although presser foot settings are made with parameters in advance, you can change the following settings according to the type and thickness of the fabric.



- No operation is possible while in "Auto Mode" on i-TM machines (optional). Hold down the "Auto Mode" icon to switch to the "Manual Mode".

### ■ Presser foot lower dead point settings

Set the height from the needle plate to the presser foot lower dead point. Make settings with consideration of the fabric thickness.

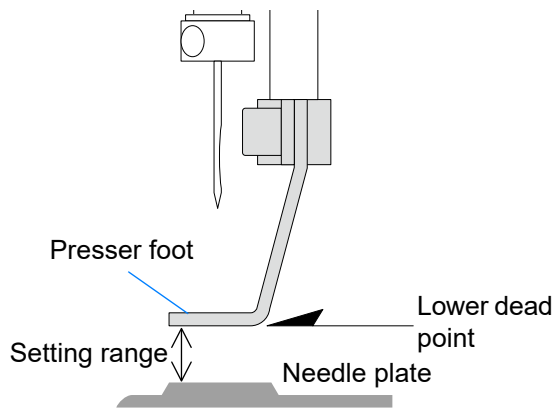

### ⚠ Caution

- Do not set the value lower than the thickness of the fabric. Doing so may cause the presser foot to come in contact with a part where the fabric is piled up and raised, and the machine may be damaged.

Setting range: 0.3 to 6.3 mm

### ■ Presser foot stroke settings

Set the presser foot stroke.

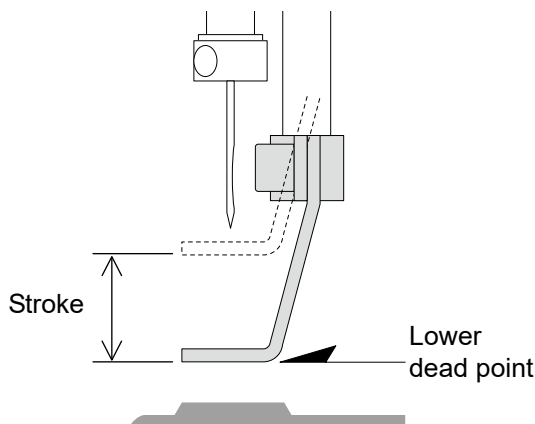

- If the stroke becomes too large, problems can easily occur. Set the value by checking the embroidery condition.

Setting range: Functional limit level 1: 5.0 to 22.0 mm  
 Functional limit level 2, SEL: 2.0 to 22.0 mm

## ■ Presser foot timing settings

Set the timing for when the presser foot starts to move down.

The smaller the setting value, the earlier the moving down timing of the presser foot. A larger setting value causes the timing to be delayed.

The mutual relation between the lower dead point, the stroke, the setting range of the presser foot timing, and the position of the needle is roughly illustrated below for your reference.

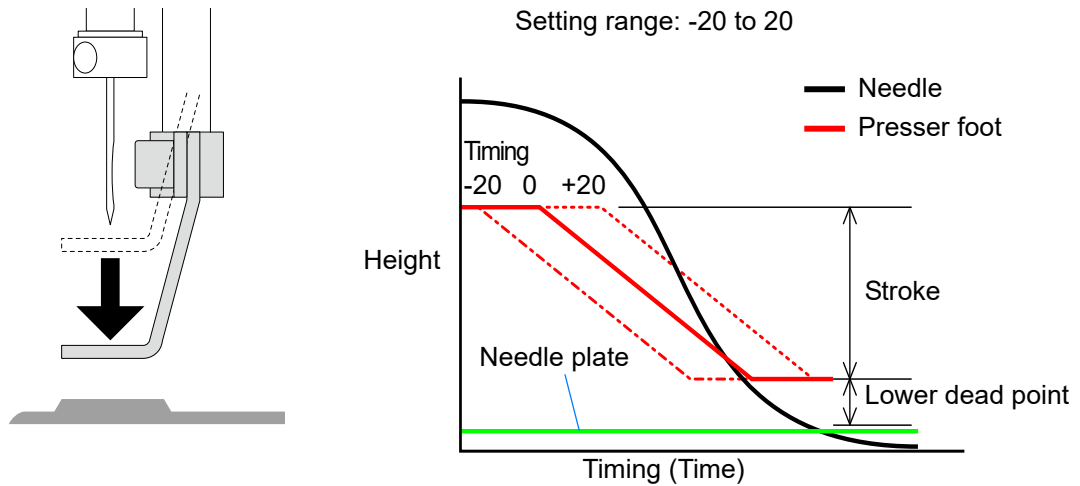

## ■ Presser foot F. B. lower dead point settings

Set the presser foot height (from the presser foot lower dead point to the presser foot F.B. lower dead point) when performing Frame Back.

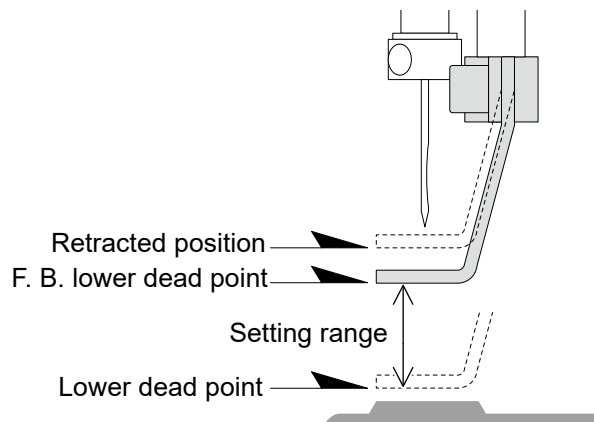

Setting range: 5.0 to 22.0 mm, R. (retracted position)

## 3-2. About the setting operation

Presser foot settings are possible using any of the following three screens: Parameter setting screen, needle bar setting screen, and manual operation screen.

In the case of duplicated settings, those set in the needle bar setting screen will take precedence, followed by those set in the parameter setting screen or manual operation screen.

### Settings on parameter setting screen

Make presser foot settings that serve as the basis of the entire machine or individual needle bars.

These are basic settings, so the machine will continue sewing with the same settings regardless of design changes.

Initial settings are registered in advance using parameters.

Furthermore, if settings are made on the needle bar setting screen, settings on the needle bar setting screen take precedence over parameter settings.

### Settings on the needle bar setting screen

Make presser foot settings for the selected design per needle bar step.

You can make presser foot settings that vary with each step for the same needle bar.

Values set on the needle bar setting screen are saved with the design data.

### Settings on the manual operation screen

You can change presser foot settings during embroidery.

Make presser foot settings for the needle bar currently being used.

Like parameter settings, the machine will continue sewing with the same settings regardless of design changes.

Values set on the manual operation screen are saved as parameter settings.



- For more information about the needle bar setting screen, refer to "Chapter 2 3-3. Settings on the needle bar setting screen".
- For more information about the manual operation screen, refer to "Chapter 2 3-4. Settings on the manual operation screen".

### 3-3. Settings on the needle bar setting screen

Make presser foot settings for the selected design per needle bar step. The set value will be stored with the design data.

You can make the following presser foot settings on the needle bar setting screen: presser foot lower dead point, presser foot stroke, presser foot timing, and presser foot F.B. lower dead point.

The following example shows how to set the height of the "presser foot lower dead point".



- 
 Settings for the "Presser foot lower dead point" are not possible while in "Auto Mode" on i-TM machines (optional). Hold down the "Auto Mode" icon to switch to the "Manual Mode".



1 Press  on the main screen.

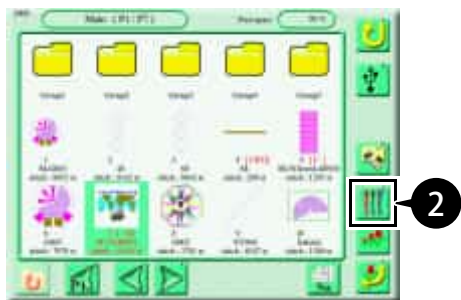

2 Press .

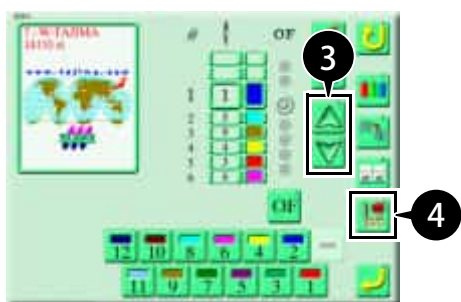



3 Press  , and select the step.

4 Press .



5 Select the "Presser foot lower dead point".

6 Press  , and set the height of the lower dead point.

7 Press .

### 3-4. Settings on the manual operation screen

Make presser foot settings for the entire machine "Any" or for the needle bar step.

Values set manually are saved as parameter settings for the entire machine or for individual design steps.

You can make the following presser foot settings on the manual operation screen: lower dead point, stroke mode, stroke, timing, and F.B. lower dead point.

The following example shows how to set the height of the "lower dead point" of the needle bar currently being used.



- This operation cannot be performed when the functional limit level is set to "2".
-  Settings for the "Presser foot lower dead point" are not possible while in "Auto Mode" on i-TM machines (optional).

Hold down the icon to switch to the "Manual Mode".

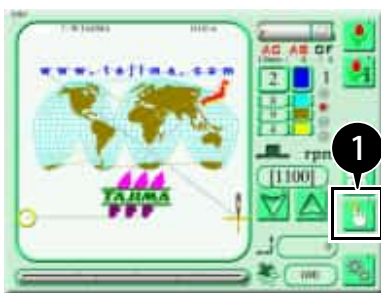

1 Press  on the main screen.

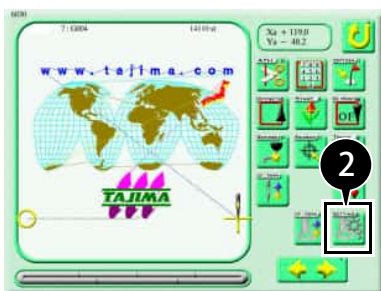

2 Press .

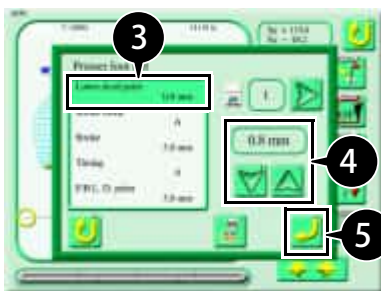

3 Select "Lower dead point".

4 Press , and set the height of the lower dead point.



- When making "Stroke" settings, first set the "Stroke Mode" to "M" (Manual).

5 Press .

## 4. Responding to Thread Breakage

### 4-1. How to respond to a thread breakage indicator

When a thread breakage is detected, the machine automatically stops and the multi-color LED (right side) on the head where the thread breakage occurred lights up or blinks in red. In addition, error No. 291 or 293 appears on the operation panel.

How to respond to a thread breakage differs, depending on whether the LED lights up or blinks and which error No. is displayed.

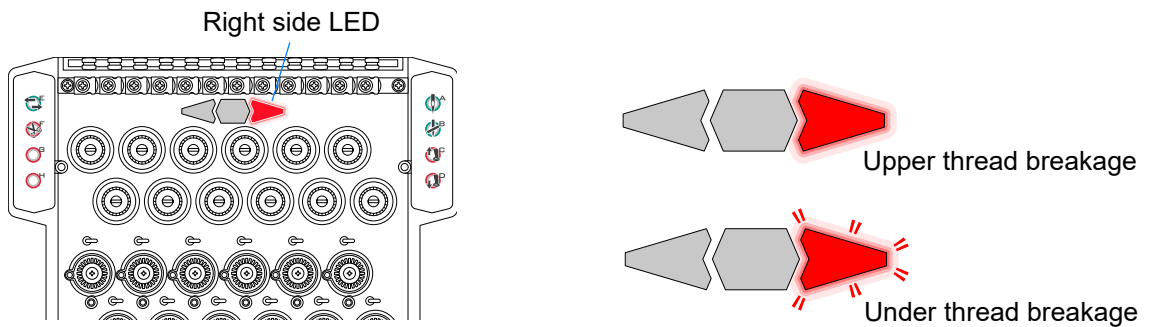

Display	Condition	Troubleshooting
Lit (Error No. 291)	Upper thread breakage	Pass the broken upper thread through the needle.
Blinking (Error No. 293)	Under thread breakage	Remove the bobbin from the rotary hook and check the condition of the under thread. If the under thread is gone or the remainder is low, replace the bobbin with a new one.



- Once you pass the upper thread or replace the under thread and resume embroidery, the error message screen disappears.

## 4-2. Repair stitches

During the period between when a thread breakage occurs and when the machine stops, the frame advances without the thread for several stitches and thus a part of the design goes missing. To resume embroidery after a thread breakage, move the frame back from the position where it was stopped and resume embroidery at such a position that the stitches overlap a little for better finishing.

### ■ An overview of repair stitches

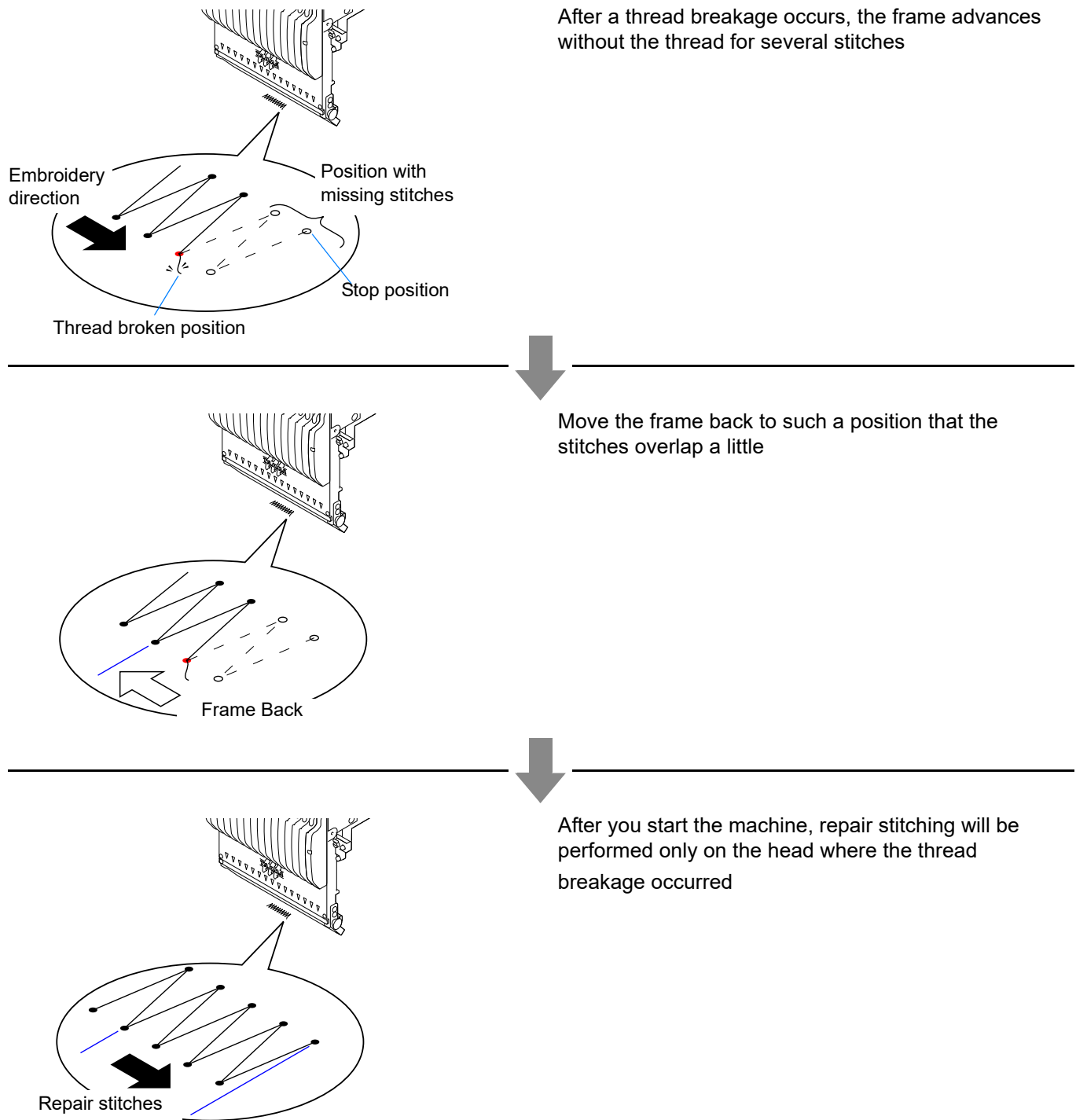

- If the "Auto F.B. after T. Detection" parameter is set to "Yes", the frame automatically moves back after a thread breaks. For details, refer to the separate "Parameter Settings" manual.

## How to operate

The following example shows how to perform return stitching and repair stitching only with the head where a thread breakage occurred.



- For more information on return stitching, refer to "Chapter 1 4. Direct Command Switch".

## Caution



Do not put your hands near the needles or on the table when you operate the machine. Doing so may cause your finger or hand to be injured when the needle bar or frame moves.

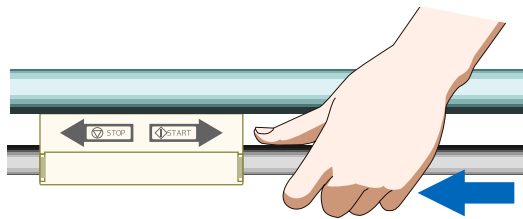

- 1 Move the bar switch to the left to move the frame back to a position where the stitches slightly overlap.



- For more information on moving the frame back (Frame Back), refer to "Chapter 4 1. Moving the Frame Back or Forward Using Stitches".

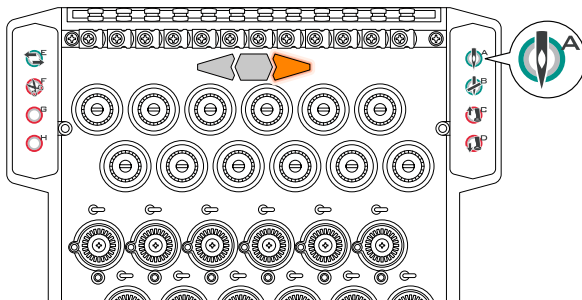

- 2 Press once on the tension base of the head where the thread breakage occurred. The multi-color LED (right side) changes in color from red to orange.

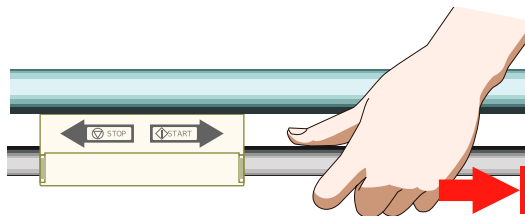

- 3 Move the bar switch to the right. The machine starts, and only the head with broken threads performs return stitching and repair stitching.

# Chapter 3

## i-TM

### 1. Features of the i-TM System

The i-TM system optimizes the embroidery finish by pre-reading stitch data of the data-set design, determining the stitch type (running or satin stitch), sewing direction, and sewing pitch, and controlling the supply of upper thread on a stitch-by-stitch basis according to the result of that determination.

Upper thread control will be automatically controlled on the i-TM tension base when embroidering, thus eliminating the operator’s need to adjust the tension of each upper thread. This will save time and effort in tension adjustment and test sewing.

#### ■ Function outline

When a design is stored in the machine memory, the i-TM function will automatically calculate predetermined control data for each stitch. Furthermore, control data is grouped per needle bar step and stored as a control pattern for the design.

Therefore, in the case of sewing the same design, the supply of upper thread will be controlled according to the stored control pattern of the design.

Each control pattern is stored for the design with the Pattern Number (Machine number\_N Needle bar No.).

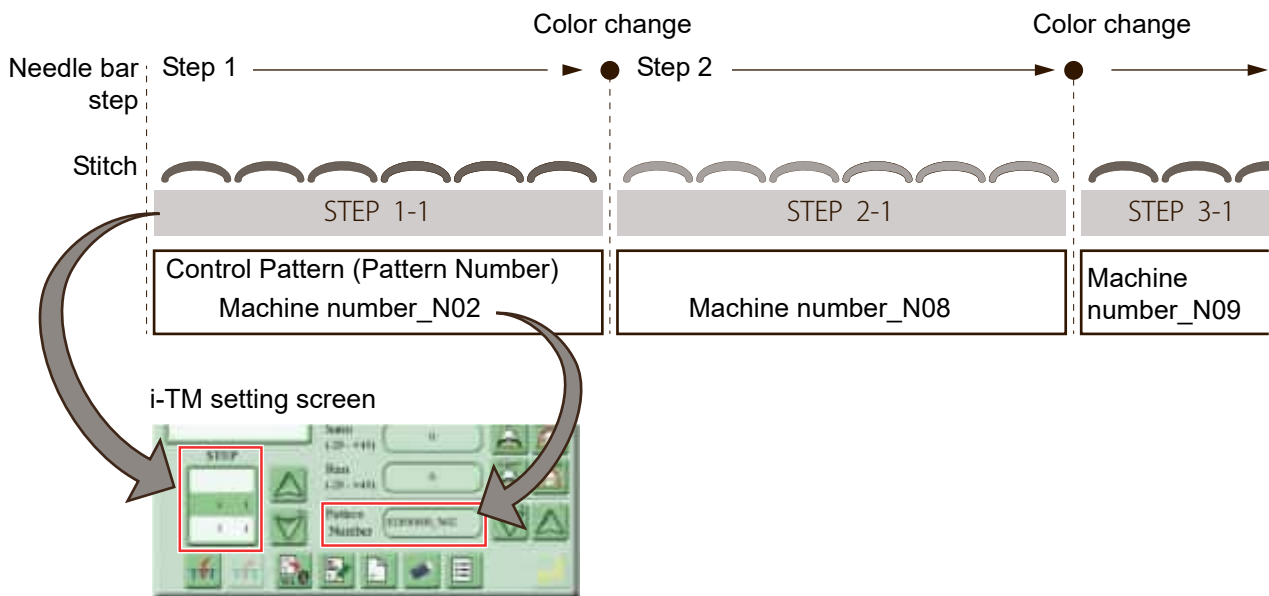

In addition, the following adjustments and changes are also possible according to the finished embroidery condition.

- Splitting the control pattern for each needle bar step and sub-splitting the control pattern.
- Overwriting and saving the adjusted control pattern or storing it with a different name.

#### ■ Mode switching

i-TM has Auto mode and Manual mode. Switch modes on the main screen or by parameters.

- Auto mode: Each i-TM parameter will be adjusted automatically by measuring the fabric thickness (Default).
- Manual mode: Each i-TM parameter can be adjusted manually.

## 2. i-TM Setting Screen

On the main screen, holding down  or  for more than two seconds will allow you to switch between "Auto Mode" and "Manual Mode".

### 2-1. Auto mode

Pressing  displays the i-TM adjustment screen. Then, you can adjust both satin and running stitches simultaneously.



No.	Description	No.	Description
1	Tighten	3	Loosen
2	Return to the previous screen	4	Settings take effect

## 2-2. Manual mode

Pressing  displays the i-TM setting screen. Then, you can individually adjust satin and running stitches and register the values.

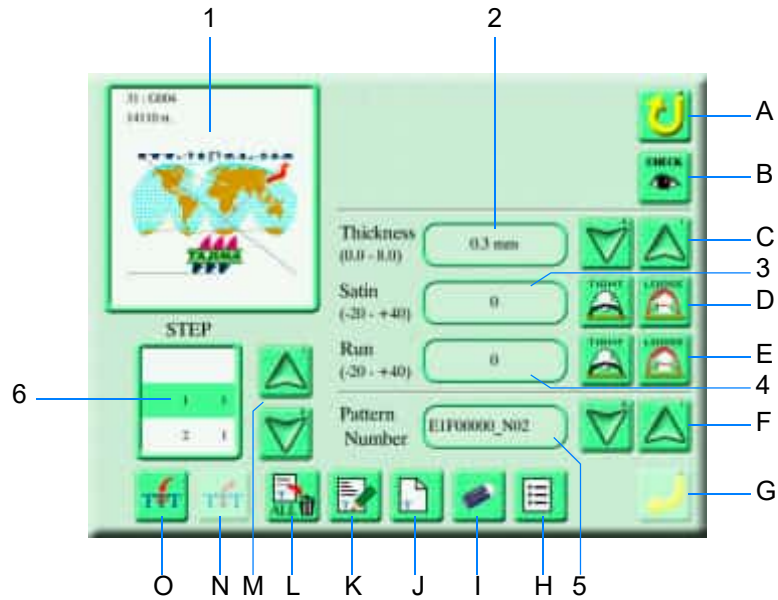

No.	Description	No.	Description
1	The selected step blinks	E	Running stitch change
2	The setting value of the current fabric thickness	F	Control pattern change
3	The setting value of the current satin stitch	G	Saving the setting
4	The setting value of the current running stitch	H	Navigate to the pattern list screen
5	Current control pattern (Pattern Number)	I	Resetting of the selected control pattern
6	Selected step	J	Storing the control pattern with a name
A	Back (return to the previous screen)	K	Overwriting and saving the control pattern
		L	Batch resetting all of the control patterns
B	Navigate to the check screen	M	Step selection and scroll
C	Fabric thickness change	N	Step deletion
D	Satin stitch change	O	Step division

# 3. Adjusting the Embroidery Finish

When the i-TM mode is set to the "Manual mode", thread tightening can be adjusted for each stitch type based on the design's embroidery results.

## 3-1. Adjusting the thread tightening

### Fabric thickness change

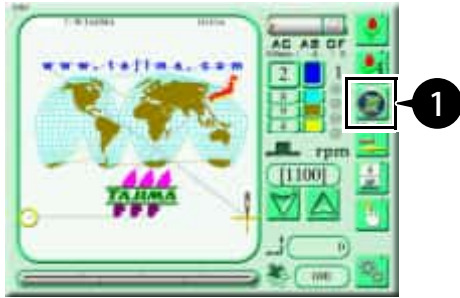



1 Press  on the main screen.



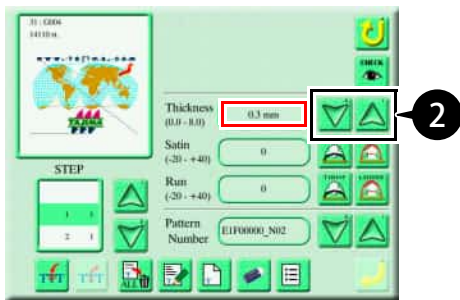

-  While in "Auto Mode", hold down the "Auto Mode" icon to switch to the "Manual Mode".



2 Press   to set the fabric thickness (Thickness).  
The new setting appears in the red box.

### Satin stitch adjustment



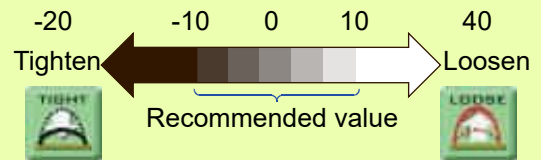

3 Press   to adjust the satin stitch (Satin) thread tightening.  
The new setting appears in the red box.

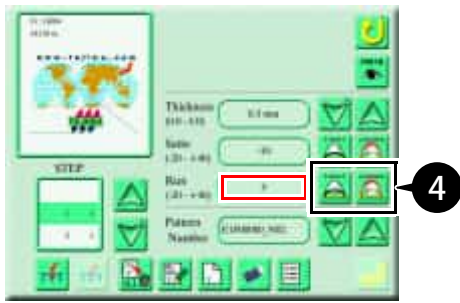

- Lower the detecting sensitivity for thread breakage in the case of thread breakage mis-detection if the satin stitch is set to an extremely high or low value. For details, refer to the separate "Parameter Settings" manual.

### Running stitch adjustments



- 4 Press   to adjust the running stitch (Run) thread tightening.  
The new setting appears in the red box.

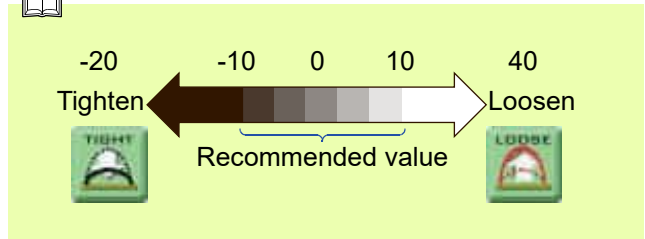

- Lower the detecting sensitivity for thread breakage in the case of thread breakage mis-detection if the running stitch is set to an extremely high or low value. For details, refer to the separate "Parameter Settings" manual.

### Storing control pattern



- 5 Store the setting value in the control pattern.



: Storing with a name



: Overwriting and saving



- For details of storing the setting value with a name, refer to "Chapter 3 4-1. Storing the control pattern with a name".
- For details of overwriting and saving the setting value, refer to "Chapter 3 4-2. Overwriting and saving the control pattern".



- 6 Press .

The setting will be stored.

### 3-2. Adjusting the thread tightening during operation

You can check and make thread tightening adjustments while the machine is in operation.



- Satin stitch and running stitch changes are possible while the machine is in operation.



- 1 Temporarily adjust the thread tightening of the satin stitch and running stitch on the i-TM setting screen while the machine is in operation.



- For adjustments to the thread tightening of the satin stitch and running stitch, refer to "Chapter 3 3-1. Adjusting the thread tightening".

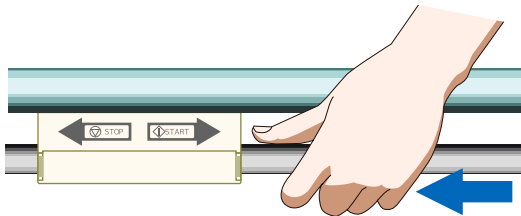

- 2 Stop the machine using the bar switch and check the stitch.

When the machine stops, the temporary adjustment value returns to the value before adjustment.



- The temporary adjustment values will not be reflected in the control pattern when the machine is stopped.



- 3 Press .

The temporary adjustment value is displayed.



- If the control pattern changes during temporary adjustment, the temporary adjustment value will be cleared, and the value will not be displayed with

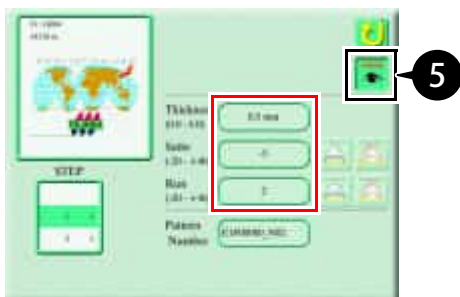

- 4 Check the value of temporary adjustment (red frame part).

- 5 Press .

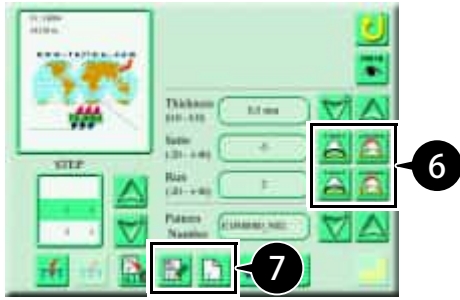

6 Set the thread tightening of the satin stitch or running stitch by referring to the temporarily adjusted value confirmed at for step 4.



- For thread tightening settings for the satin stitch and running stitch, refer to "Chapter 3 3-1. Adjusting the thread tightening".

7 Store the setting value in the control pattern.



: Storing with a name



: Overwriting and saving



- For details of storing the setting value with a name, refer to "Chapter 3 4-1. Storing the control pattern with a name".
- For details of overwriting and saving the setting value, refer to "Chapter 3 4-2. Overwriting and saving the control pattern".



8 Press  .

The setting will be stored.

## 4. Storing the Control Pattern (Pattern Number)

You can store the changed fabric thickness and thread tightening settings for the adjusted stitch in a control pattern.



- The default setting for a control pattern is "Machine number\_N Needle bar No.", and all control pattern setting values are the same.
- You can create up to 1,000 control patterns per design.

### 4-1. Storing the control pattern with a name

You can store the changed fabric thickness or thread tightening settings for the adjusted stitch in a control pattern with a name.



- 1 Make fabric thickness settings or thread tightening settings for the stitch on the i-TM setting screen.



- For fabric thickness settings or stitch thread tightening settings, refer to "Chapter 3 3. Adjusting the Embroidery Finish".



- 2 Press  .



- 3 Enter the new control pattern name (for example TT001).



- You can enter a control pattern name up to 24 characters long.
- Press  to toggle between uppercase and lowercase.

- 4 Press  .

The setting for the new control pattern will be stored.

## 4-2. Overwriting and saving the control pattern

You can overwrite and save the changed fabric thickness and thread tightening settings for the adjusted stitch in a control pattern.



- 1 Make fabric thickness settings or thread tightening settings for the stitch on the i-TM setting screen.



- For fabric thickness settings or stitch thread tightening settings, refer to "Chapter 3 3. Adjusting the Embroidery Finish".



- 2 Press  .



- The save method is different if there is more than one control pattern with the same name in one design. For details, refer to "Chapter 3 5-1. Step division and setting".



- 3 Press  .

The setting for the control pattern will be overwritten and saved.

## 5. Step Division

You can divide the control pattern for each needle bar step for the segmentation of the control pattern.

[In the case of dividing the needle bar step 2]

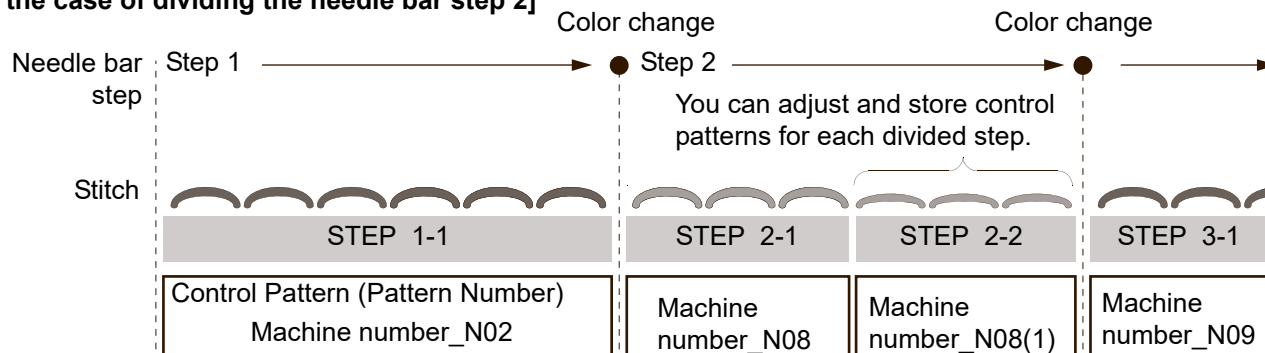

### 5-1. Step division and setting

You can divide the step before and after the specified stitch No. and set a control pattern.



The previous step includes all the stitches before the specified stitch No.

The following example shows how to divide the step with stitch No. 912 specified.

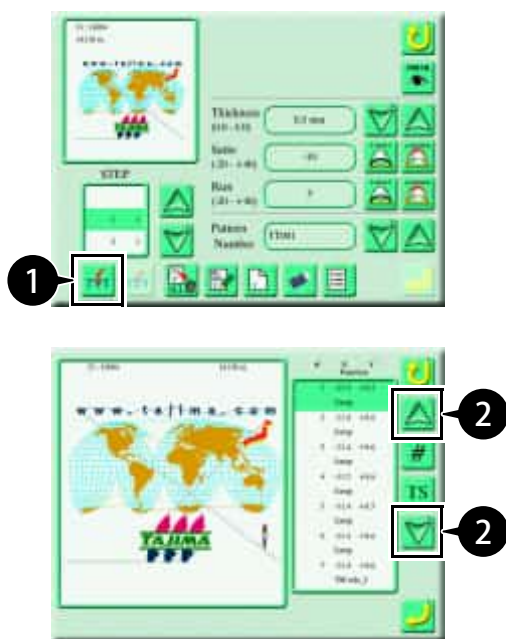

#### ■ Step Division



1 Press  on the i-TM setting screen.

2 Press   and move to the stitch count to the dividing position.



- Hold down   to change the display in units of seven stitches.
- Pressing  will display a numerical key so that you can input the stitch No. of the dividing position and move to the target position.

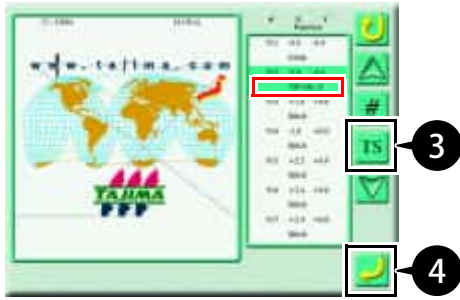

3 Press **TS** and specify the stitch position for division.

The function code display of your specified stitch will change (as shown in the red box).



- Function code display change  
 "TSCode\_S" : Stitch  
 "TSCode\_J" : Jump

4 Press  .

5 Press **Yes** .

The step is divided.



**Setting and storing a control pattern**

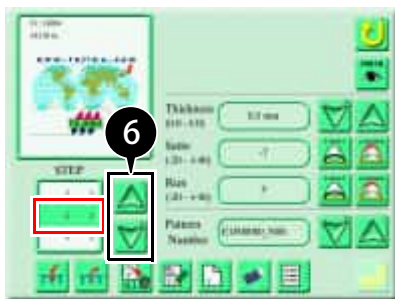

6 Press  and select the divided step.

The selected step appears in the red box.

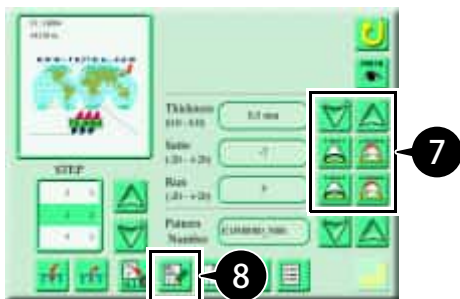

7 Make fabric thickness settings or stitch thread tightening settings.



- For fabric thickness settings or stitch thread tightening settings, refer to "Chapter 3 3. Adjusting the Embroidery Finish".

8 Press  .



9 Select the storage method.



: Overwriting and saving the selected control pattern



: Overwriting and saving all the control patterns with the same name



10 Press  .

The setting for the control pattern will be stored.





- If there are two or more control patterns with the same name, a number will be added at the end of the control patterns (as shown in the red box).

## 5-2. Deleting a divided step

You can delete a divided step.

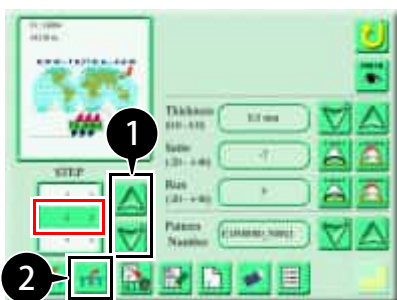
You cannot delete steps unless they have been divided and created.



1 Press  and select the divided step on the i-TM setting screen.

The selected step appears in the red box.

2 Press  .



-  is valid only if the divided step is selected.

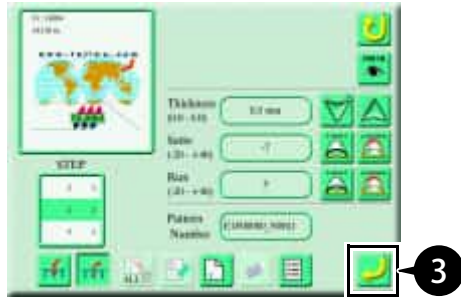

3 Press  .

The selected step is deleted.

## 6. Resetting of the Control Pattern

### 6-1. Resetting of the selected control pattern

You can reset the name and set value of the selected control pattern.

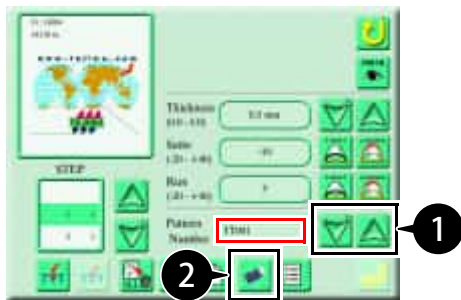

- 1 Press  and select the target control pattern on the i-TM setting screen.  
The selected control pattern appears in the red box.

- 2 Press .

- 3 Press .

The control pattern is reset.



- Setting value after the control pattern is reset.  
Fabric thickness: 0.3 mm  
Satin stitch: 0  
Running stitch: 0  
Pattern Number: Machine number\_N Needle bar No.



## 6-2. Batch resetting all of the control patterns

You can batch reset the names and set values of all control patterns saved for the design.



- Divided steps will remain, but the set values of the control patterns allocated will be reset.



1 Press  on the i-TM setting screen.



2 Press .

The control pattern is reset.



- Setting value after the control pattern is reset.  
Fabric thickness: 0.3 mm  
Satin stitch: 0  
Running stitch: 0  
Pattern Number: Machine number\_N Needle bar No.

# 7. List Display and Editing of Control Patterns



You can display a list of data-set design control patterns. Furthermore, you can edit or delete any of them independently.

## 7-1. List display of control patterns

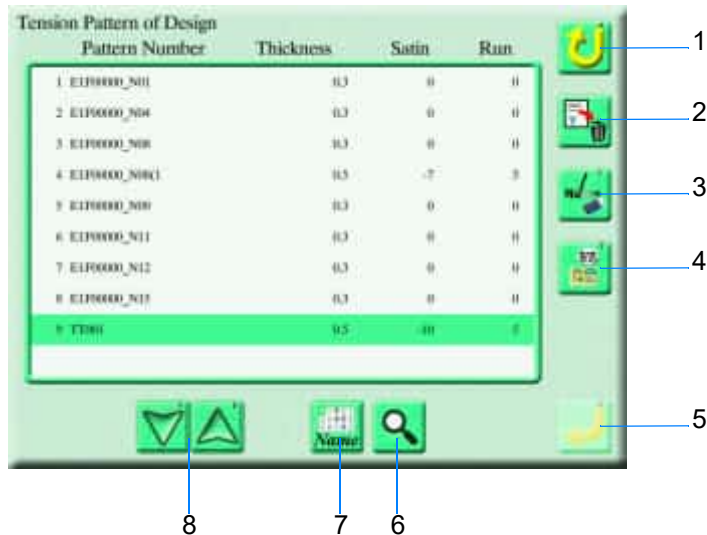

- 1 Press  on the i-TM setting screen.  
The pattern list screen appears.



No.	Description
1	Return to the previous screen
2	Delete control patterns (Control patterns grouped per needle bar step will not be deleted but their names and setting values will be reset)
3	Change control pattern name
4	Navigate to the detailed setting screen
5	Decision
6	Search by control pattern name
7	Switch ascending order  : Name  : Updating time
8	Switch display page

## 7-2. Searching control pattern by name



1 Press  on the pattern list screen.



2 Enter the control pattern name (for example E1F0000\_N08 (1)) to be searched for.



- You cannot search unless you enter the full name.
- Press  to toggle between uppercase and lowercase.

3 Press .

The input control pattern appears in the red box.

## 7-3. Adjusting fabric thickness and stitch thread tightening (detailed setting screen)

You can change the fabric thickness of the specified control pattern or change the adjustment for stitch thread tightening.



- Contact your distributor for adjustments other than fabric thickness, satin stitch, and running stitch.

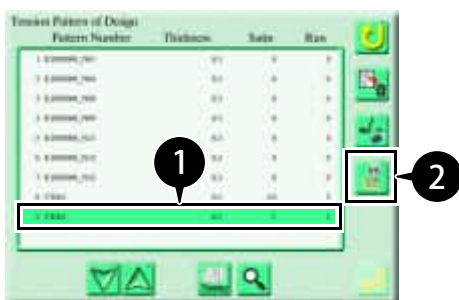

1 Select the target control pattern (for example TT002) to change the setting on the pattern list screen.

2 Press .

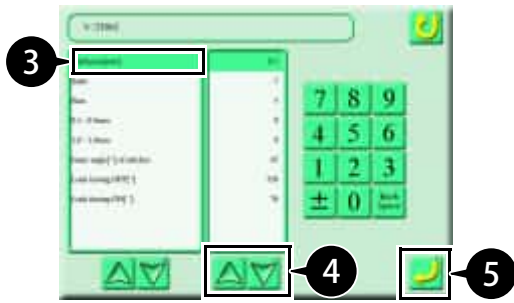

3 Select the setting you want to change (for example Thickness [mm]).

4 Press   and change the value.

5 Press  .  
The setting will be changed.

## 7-4. Deleting control pattern

You can delete the specified control pattern.

You cannot delete control patterns grouped per needle bar step but their names and setting values will be reset.



1 Select the target control pattern (for example E1F00000\_N08 (1)) to be deleted on the pattern list screen.

2 Press  .



3 Press  .  
The selected control pattern will be deleted.



- In the case of control patterns grouped per needle bar step, their names and setting values will be reset.
- Setting value after the control pattern is reset.  
Fabric thickness: 0.3 mm  
Satin stitch: 0  
Running stitch: 0  
Pattern Number: Machine number\_N Needle bar No.

### 7-5. Changing control pattern name



1 Select the target control pattern (for example E1F00000\_N08 (1)) for the name to be changed, on the pattern list screen.

2 Press .



3 Input the control pattern name (for example TT002).



- You can enter a control pattern name up to 24 characters long.
- Press  to toggle between uppercase and lowercase.

4 Press .

The control pattern name will be changed.

# Chapter 4

## Manual Operation

### 1. Moving the Frame Back or Forward Using Stitches

You can move the frame back (Frame Back) or forward (Frame Forward) using stitches with the machine stopped. This feature is useful when you want to:

- Resume embroidery from a stitch before the position where a thread breakage occurred for the purpose of performing repair stitching.
- Resume embroidery from within the design or from an intermediate step
- Skip an area within the design or an intermediate step

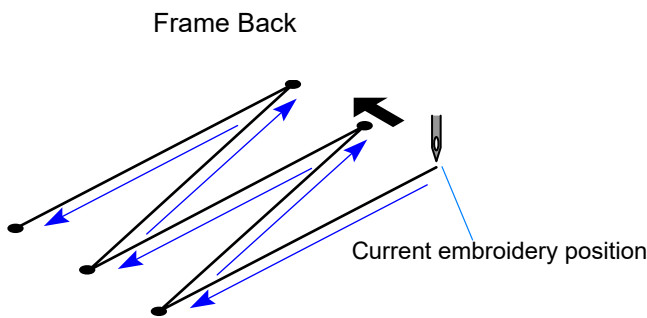

The frame will be moved in the direction where stitches return with the machine stopped.

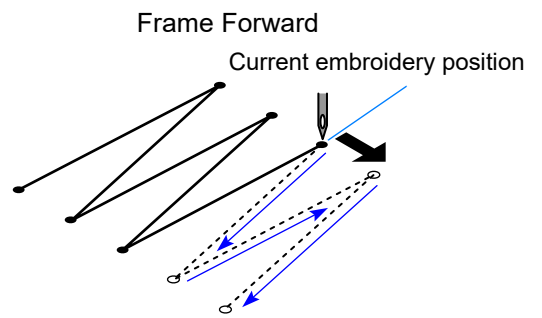

The frame will be moved in the direction where stitches advance with the machine stopped.

You can use the Frame Back and Frame Forward features in one of the following three ways:

Method	Unit	Detail
Bar switch	Stitch	Move the frame back/forward on a stitch by stitch basis using stitches.
Operation panel		Move the frame back/forward using the stitch count you specify.
Operation panel	Color change	Move the frame back/forward by the number of color change codes you specify.

## 1-1. Frame Back/Frame Forward by 1-stitch unit

You can use the bar switch to move the frame back or forward on a stitch-by-stitch basis.

### ⚠ Caution

- Do not put your hands on the table when you operate the machine. Doing so may cause your finger or hand to be injured when the frame moves.

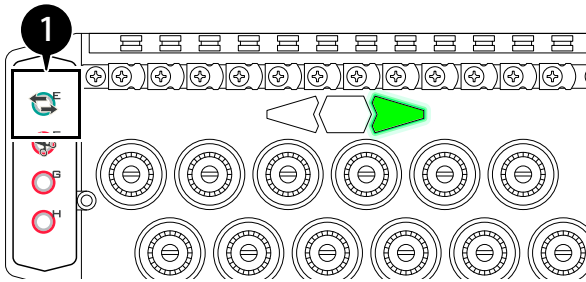

- Press  on the tension base to switch between Frame Back and Frame Forward.



- The multi-color LED lighting color changes every time you press the switch and blinks white for 2 seconds once the setting has changed.



: Frame Back (left side lights up)

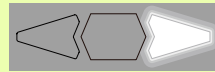

: Frame Forward (right side lights up)

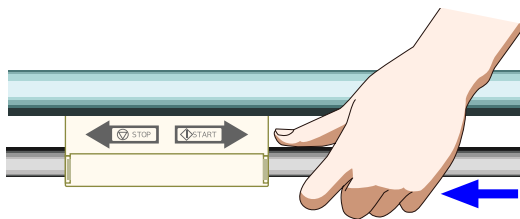

- Move the bar switch to the left and hold it in that position.  
The frame moves on a stitch by stitch basis along the stitches.
- Release the bar switch when the frame moves to the desired frame position (within 10 stitches).  
The frame stops moving.

### ■ High-speed travel of Frame Back/Frame Forward

Moving the bar switch to the left and hold it for 11 or more stitches, the frame switches to high-speed travel (feed unit). To stop high-speed travel, move the bar switch to the left again.

For this mode, you can configure the frame feed amount for high-speed travel. For details, refer to the separate "Parameter Settings" manual.

[Frame Back]

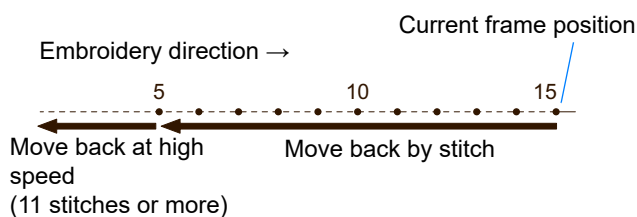

[Frame Forward]

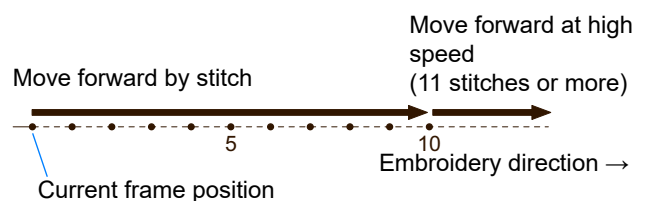

## 1-2. Frame Back/Frame Forward by specifying a number of stitches

You can move the frame back or forward by the number of stitches you specify.

### Caution

-  Do not put your hands on the table when you operate the machine. Doing so may cause your finger or hand to be injured when the frame moves.

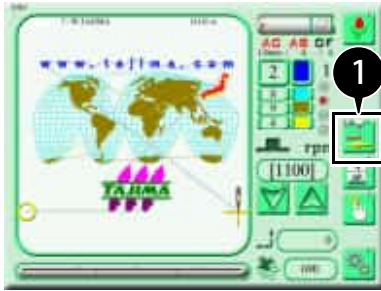

1 Press  on the main screen.

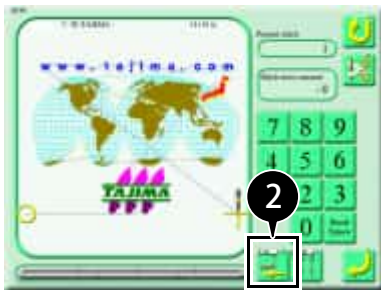

2 Select the direction in which to feed the frame.



: Frame Back



: Frame Forward



3 Input the number of stitches (for example, 500).

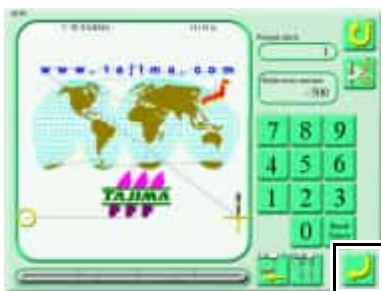

4 Press .

The frame moves through the design by the specified number of stitches.

1  
2  
3  
4  
5  
6  
7  
8  
9  
10

### 1-3. Frame Back/Frame Forward by specifying a number of color change codes

You can move the frame back or forward by specifying the number of color change codes.

#### Caution

 Do not put your hands on the table when you operate the machine. Doing so may cause your finger or hand to be injured when the frame moves.

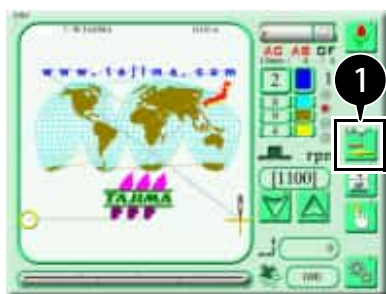

1 Press  on the main screen.

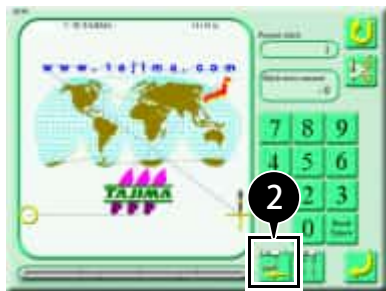

2 Select the direction in which to feed the frame.



: Frame Back



: Frame Forward

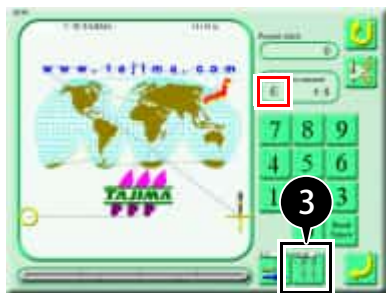

3 Press  for as many times as the desired number of color change codes.



- For the "C" display, "E" appears in the red box if there is no next color change and the current color change is the last one.

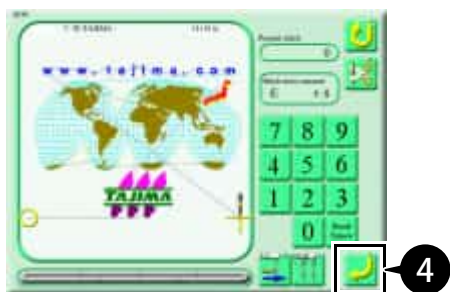

4 Press .

The frame moves through the design by the selected number of color change codes to the specified point of the design.

# 2. Thread Trimming

## 2-1. Operating the ATH

You can trim both the upper and under threads or only the under thread.

### ⚠ Caution

Do not put your hands near the needles or on the table when you operate the machine. Doing so may cause your finger or hand to be injured when the needle bar or frame moves.



You can also perform thread trimming by holding down the F switch on the tension base. For details, refer to "Chapter 1 4. Direct Command Switch".

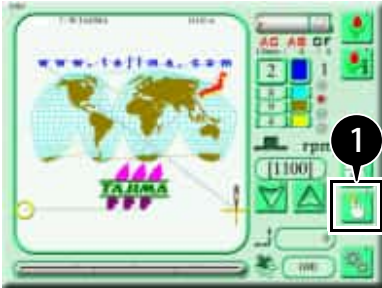

1 Press  on the main screen.

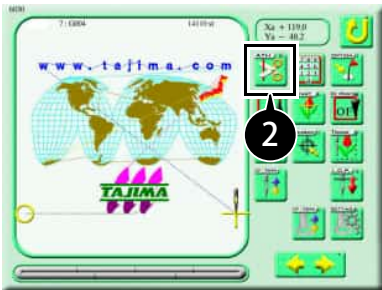

2 Press .

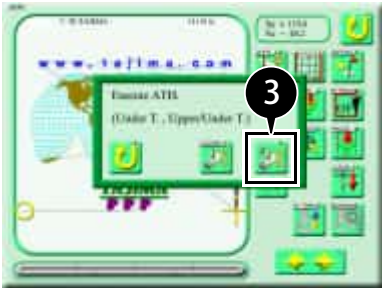

3 Execute thread trimming.

 : Under thread only

 : Upper and under threads

# 3. Needle Bar Related Operations

## 3-1. Color change

A color change is performed by sliding the needle bar case and switching from one needle bar to another.

### ⚠ Caution

- ⊘ Do not bring your hand close to the needle bar case when you operate the machine. Doing so may cause your finger or hand to be injured when the needle bar case moves.



- If the thread is connected to the fabric, trim the thread before the color change.
  - If you manually switch the needle bar and want to use the new one for embroidery, set the "Auto Color Change (AC)" parameter to "NO".
- For details, refer to the separate "Parameter Settings" manual.

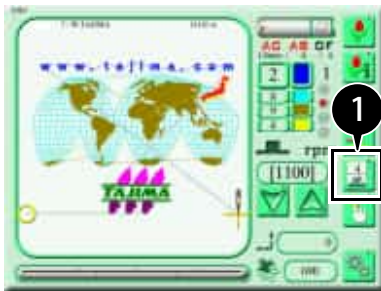

1 Press  on the main screen.

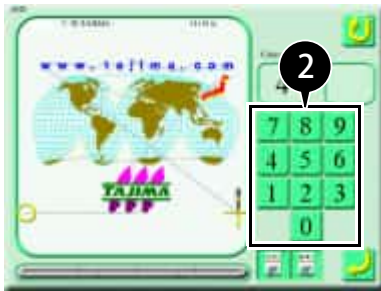

2 Select the new needle bar No. (for example, needle bar No. 8).

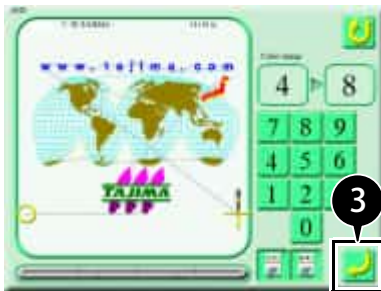

3 Press  .  
The needle bar case slides to the new one.

## 3-2. Raising or lowering the needle bar

You can drop the selected needle bar by one stitch or raise/lower it.

### Caution

-  Do not put your hands near the needles when you operate the machine. Doing so may cause your finger or hand to be injured when the needle bar moves up and down.

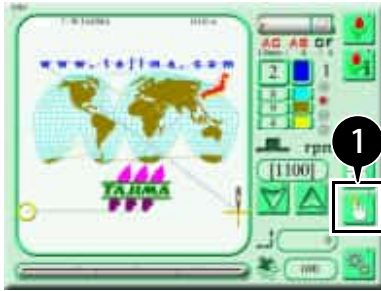

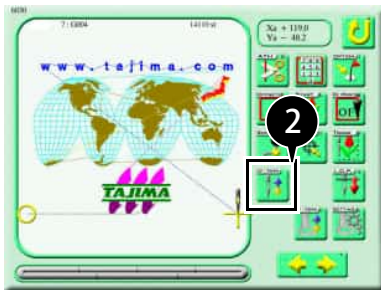

- 1 Press  on the main screen.



- 2 Press .



- 3  : Drop the needle bar once.

 : Lower the needle bar.

 : Raise the needle bar.

### 3-3. Stopping the needle bar at the lower dead point

You can lower the selected needle bar for all heads to the lower dead point.



- Since the needle bar lowers to the lower dead point, the needle remains penetrating the fabric. This feature is useful when you switch fabric while embroidering consecutively on long fabric.

#### Caution

- Do not put your hands near the needles when you operate the machine. Doing so may cause your finger or hand to be injured when the needle bar moves down.

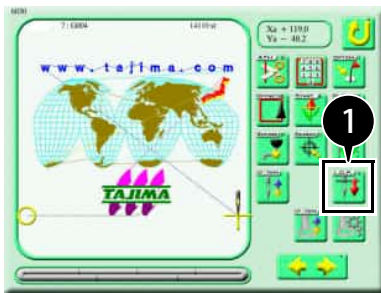

1 Press on the manual operation screen.

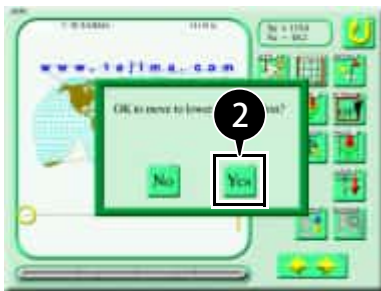

2 Press .  
The needle bar lowers to the lower dead point.

### 3-4. Raising or lowering the presser foot

You can lower or raise the presser foot of the current needle bar.

#### Caution

-  Do not put your hands near the needles when you operate the machine. Doing so may cause your finger or hand to be injured when the presser foot raises or lowers.

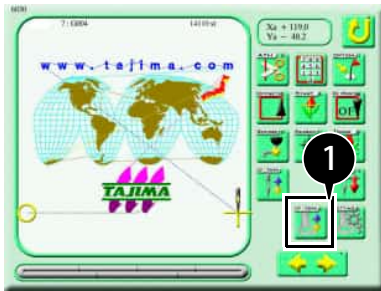

- 1 Press  on the manual operation screen.

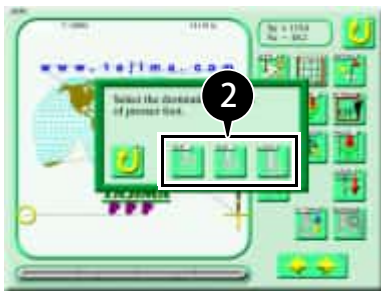

- 2 Raise or lower the presser foot.



: Retracted position



: Frame Back Position



: Presser foot lower dead point

1

2

3

4

5

6

7

8

9

10

# 4. Various Frame Movement Operations

## 4-1. Moving the frame to the preset optional position

You can move the frame to a preset optional position.



- For more information on presetting a frame position, refer to the separate "Parameter Settings" manual.

### ⚠ Caution



Do not put your hands on the table when you operate the machine. Doing so may cause your finger or hand to be injured when the frame moves.

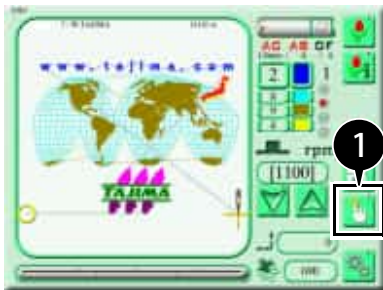

1 Press  on the main screen.

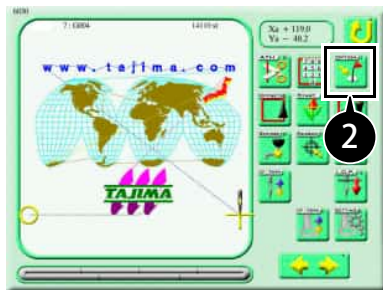

2 Press .

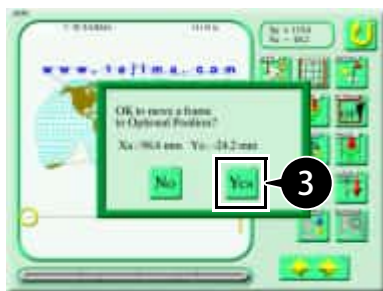

3 Press .

The frame moves to the preset optional position.

## 4-2. Moving the frame to the previous position (manual offset)

You can move the frame to the previous position after you have moved it manually.

### ⚠ Caution

- Do not put your hands on the table when you operate the machine. Doing so may cause your finger or hand to be injured when the frame moves.

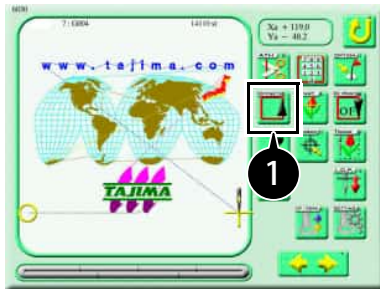

- Press  on the manual operation screen.



- Press  .  
The frame moves to the previous position.

## 4-3. Moving the frame to the start position

You can move the frame to the start position.

### ⚠ Caution

- Do not put your hands on the table when you operate the machine. Doing so may cause your finger or hand to be injured when the frame moves.

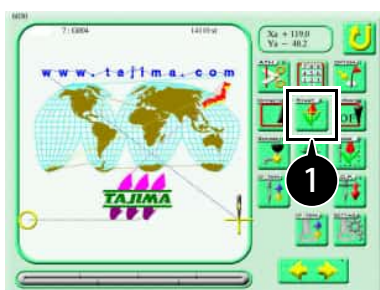

- Press  on the manual operation screen.



2 Press  .

The frame moves to the start position.

### 4-4. Moving the frame to the offset position

You can move the frame to the offset position.

The offset position is a position where the frame is automatically moved (offset toward you) during and after embroidery and put into standby for ease of replacing the frame or fabric.



- To move the frame to the offset position, you must preset it. details, refer to the "Chapter 7 1-2. Registering the offset position".

#### Caution

-  Do not put your hands on the table when you operate the machine. Doing so may cause your finger or hand to be injured when the frame moves.

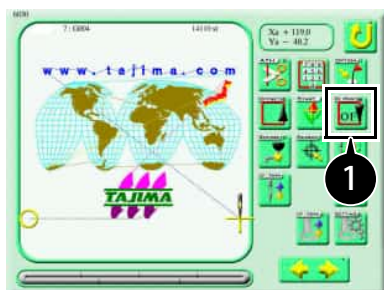

1 Press  on the manual operation screen.

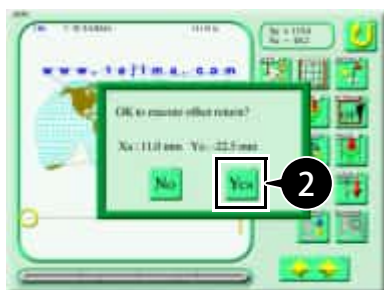

2 Press  .

The frame moves to the offset position.

## 4-5. Moving the frame by entering a numeric value

You can move the frame by entering a numeric value.





- The value you enter is the amount of travel from the current frame position.

### ⚠ Caution

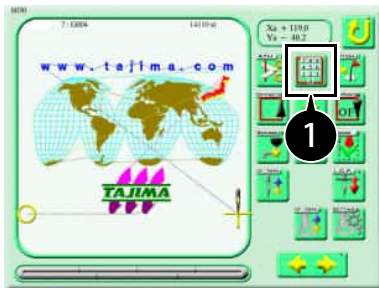

Do not put your hands on the table when you operate the machine. Doing so may cause your finger or hand to be injured when the frame moves.



1 Press  on the manual operation screen.



- Pressing the coordinate icon will change the indication.

- Current frame position

$Xa + 19.2$   
 $Ya + 98.7$  : Based on absolute origin

$Xr + 0.0$   
 $Yr + 0.0$  : Based on the start position

- Frame Travel amount from current frame position

$Xm - 20.0$   
 $Ym + 15.0$  : Travel amount you enter

$Xm -$  (minus sign): Frame moves to the right

$+$  (plus sign): Frame moves to the left

$Ym -$  (minus sign): Frame moves to the rear

$+$  (plus sign): Frame moves to the front

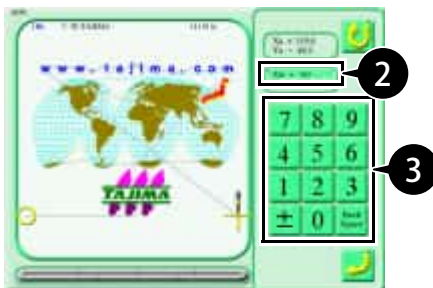

2 Press  $Xm + 0.0$ .

3 Enter the X-axis travel amount (for example, +60.0).

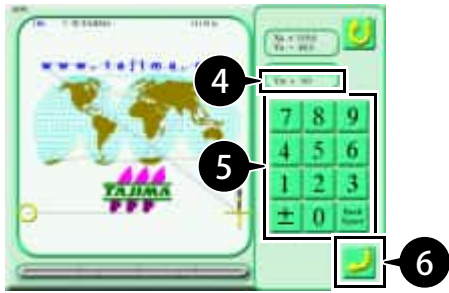

- 4 Press **Ym + 0.0** .
- 5 Enter the Y-axis travel amount (for example, -85.0).
- 6 Press  .  
The frame moves to the specified position.

### 4-6. Absolute origin search

Be sure to execute absolute origin search after you have moved the frame by hand with the power OFF.





The absolute origin of the frame is a reference point ( $X_a = 0.0$ ,  $Y_a = 0.0$ ) to calculate the current frame position. If the absolute origin is not correctly registered, the following problems may occur:

- The frame coordinates are not displayed correctly.
- After emergency stop or power failure, turning ON the power fails to return the frame to the position where the operation was interrupted.

#### Caution

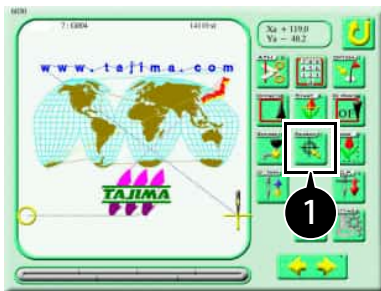
-  Do not put your hands on the table when you operate the machine. Doing so may cause your finger or hand to be injured when the frame moves.



- 1 Press  on the manual operation screen.

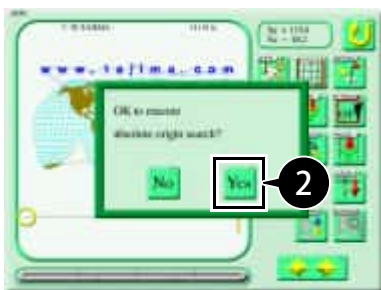

- 2 Press **Yes** .  
The frame will move to the absolute origin and return to the previous position.

## 4-7. Power resume

You can return the frame to the same position as just before the power turned off after unexpected power failure during embroidery or due to emergency stop.



- If you moved the frame by hand with the power OFF during embroidery and now want to return it to the previous position, turn ON the power and manually perform power resume. This feature requires that the absolute origin of the frame is correctly registered.

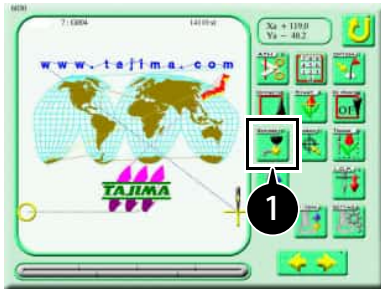

- 1 Press  on the manual operation screen.



- 2 Select the power resume method.



: Perform power resume after trimming the thread.



: Perform power resume without trimming the thread.



- When you perform power resume, the machine resets the absolute origin and the frame moves to a position several stitches prior to the position where the power was interrupted.

# 5. Other Operations

## 5-1. Turning ON/OFF the LED lamp

You can turn ON/OFF the LED lamp.

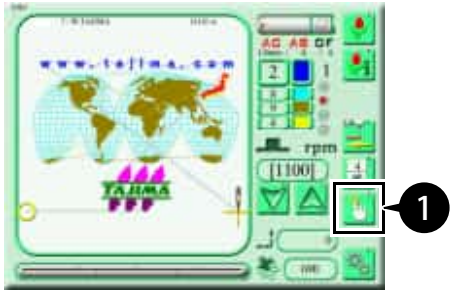

1 Press  on the main screen.

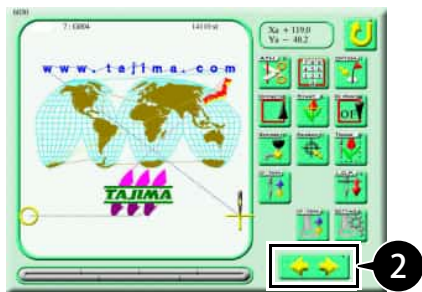

2 Press .



3 Turn ON/OFF the LED lamp.

 : Turn OFF

 : Turn ON

## 5-2. Auto lubrication system

You can operate the automatic lubrication system.

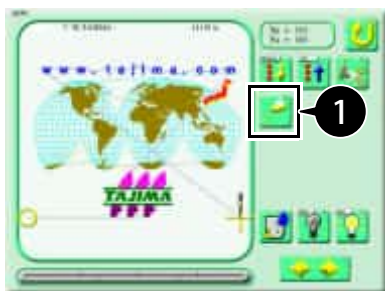

- 1 Press  on the manual operation screen.



- 2 Lubricate the rotary hook or the rotary hook and head.



: Rotary hook



: Rotary hook and head

## 5-3. Raising/Lowering the optional device

You can raise or lower the optional device (sequin or seed beads device).



- Operation is not possible unless the needle bar with the optional device is selected.

### Caution



Do not approach the raising/lowering device while it is in operation. Doing so may cause your face or hand to be injured when the device moves.

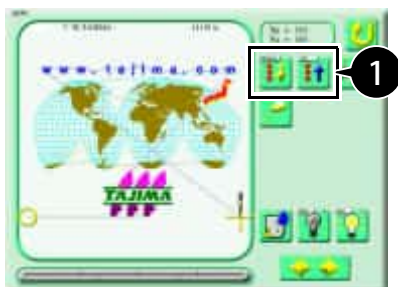

- 1 Raising/Lowering the optional device.



: Lower the optional device



: Raise the optional device



2 Press  .

The optional device lowers or raises.

# Chapter 5

## Design Management

### 1. Design Input/Output

#### 1-1. Saving designs to a USB memory

To save designs from the machine memory to a USB memory, use the following steps.

The following example shows how to select two designs and store them as "T3" data in a USB memory.



- This feature is only available if the functional limit level is set to "SEL".



1 Insert a USB memory into the USB port of the operation panel.

2 Press  on the main screen.

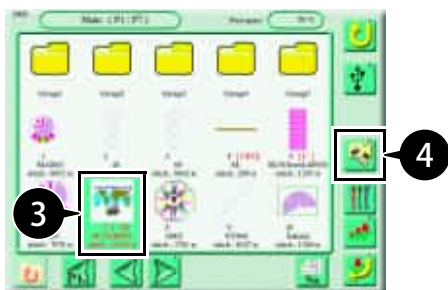

3 Select the first design you want to save.

4 Press .

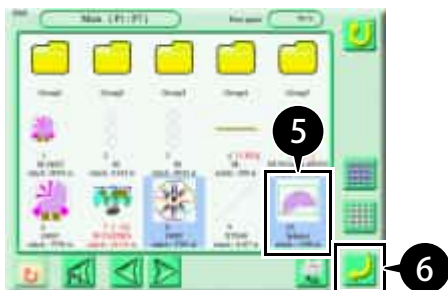

5 Select the second design you want to save.



- Press  to select all of the designs.

- Press  to deselect all of the designs.

6 Press .



7 Press  .



- If you want to save the design without changing the file name, skip to step 9.

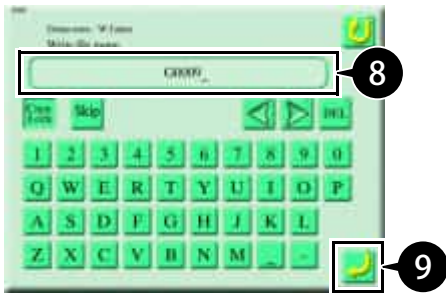

8 Change the file name of the first design you want to save.  
(For example, change to "G0009".)



- Enter up to 20 alphanumeric characters. The file name you enter will be displayed on your PC ("G0009.TCF" in this example).

9 Press  .

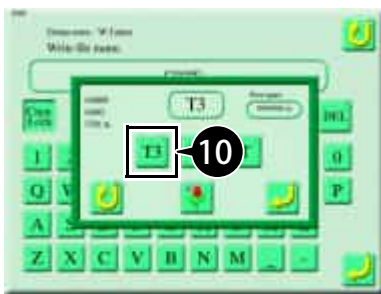

10 Press  .



- Usually, select  . For more information on the storage format, refer to "Chapter 2 2-1. Saving designs into the machine memory".

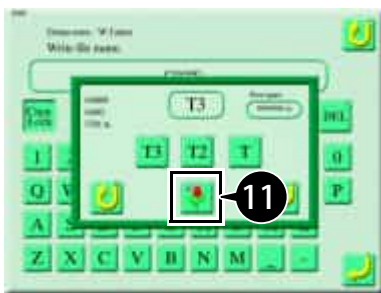

11 Select the storage format.



: Specify the storage format for each design you save.



: Save the selected designs in the same storage format.

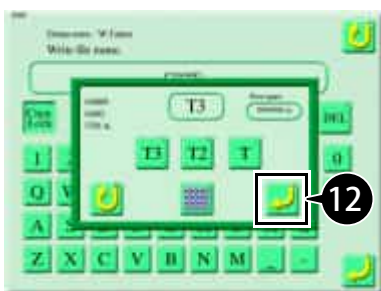

12 Press  .



- If you want to save the design without changing the file name, skip to step 14.



**13** Change the file name of the second design you want to save.  
(For example, change to "G0010".)

**14** Press .  
The designs are saved in a USB memory.

### ■ About the design display on your PC

When you read the designs saved in a USB memory (for example, file name "G0003") into your PC, they are displayed as follows:

Saving format	Display on your PC	Use
T3 (TCF)* <sup>1</sup>	G0003.TCF	Data integrating T2 (CT0, DGF, TBF) and CT1 The following conditions are included in CT1. Message S Message E
T2 (TBF)* <sup>2</sup>	G0003.CT0	Condition data (color change sequence, start position)
	G0003.DGF	Thumbnail data
	G0003.TBF	Stitch data in TAJIMA binary format
T (DST)	G0003.DST	Stitch data in TAJIMA ternary format

\*1: The T3 format consists of the following four sets of data combined into a single file:

TBF (TAJIMA binary format)	CT0 (Condition data)
DGF (Thumbnail data)	CT1 (Message)

\*2: The T2 format consists of the following three sets of data but they are not combined into a single file.

TBF (TAJIMA binary format)	CT0 (Condition data)
DGF (Thumbnail data)	

## 1-2. How to connect the machine to your PC

You can load designs saved on your PC and store them into the machine's memory.



- This operation requires you to install DG by Pulse (optional design creation software) on your PC. For more information, refer to the user's manual for DG by Pulse.

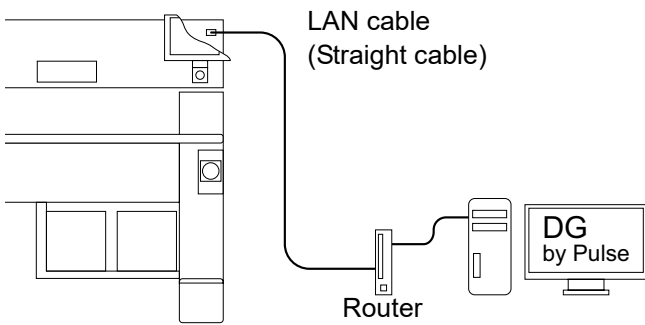

- 1 Turn OFF the PC, router, and machine and connect the LAN between the PC and machine.



- To connect the machine via a router to your PC, use an aftermarket straight cable.

- 2 Turn ON the router.
- 3 Turn ON the PC and start "DG by Pulse".
- 4 Turn ON the machine.

- 5 Press  on the main screen.



- To use this feature, enter the password to set the functional limit level to "SEL".



- 6 Press  .

- 7 Select "78. Optional device (software)".



- 8 Press  .



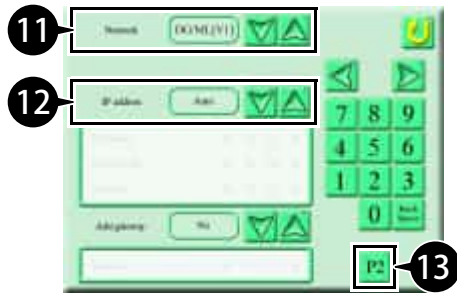

- 9 To select "1. Network".

- 10 Press  .



11 Press   next to "Network" and select "DG/ML[V1]" or "DG/ML[V2]".

12 Press   next to "IP address" and select "Auto".

13 Press  .

Various addresses are automatically acquired.



- If automatic acquisition fails, check the LAN cable connection, operating steps, and the settings of DG by Pulse.



14 Press  .

The machine and PC are connected.

1

2

3

4

5

6

7

8

9

10

### 1-3. Storing designs from your PC into the machine memory

The following example shows how to specify designs saved in your PC and store them into the machine "Main" memory.



1 Press  on the main screen.

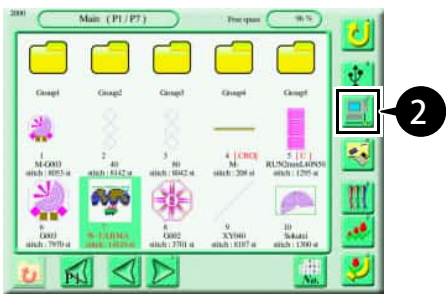

2 Press  .  
 Designs stored in DG by Pulse are displayed.



- If an icon  is displayed, it means that DG by Pulse is not connected to your PC. Refer to "Chapter 5 1-2. How to connect the machine to your PC" and connect it to your PC.



3 Select a design.  
 4 Press  .



5 Press  "Main".  
 The process of storing the design completes.

## 1-4. Storing designs from your PC into the machine memory using a barcode reader

Once you read a barcode using a barcode reader, the design is stored in the machine memory and the data is automatically set.

If you read multiple barcodes, the last design data is set.



- You can create barcodes using the print function of DG by Pulse. For more information, refer to the user's manual for DG by Pulse.
- Use an aftermarket USB-connectable barcode reader.

Barcode reader

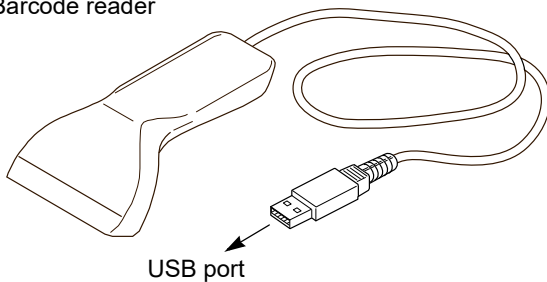

**1** Insert the barcode reader into the USB port on the operation panel.



**2** Display the main screen.



- You can also read barcodes also from the following screen numbers:  
No. 2000, No. 4100, No. 4150

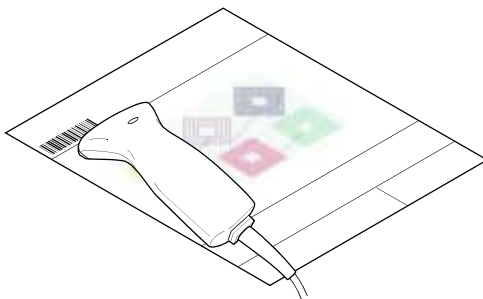

**3** Read the barcode using the barcode reader.  
The design data is set.



- If you repeatedly read the same barcode, as many times as you read it, that many designs will be stored in the machine memory.

### [If you read a barcode during embroidery]

During embroidery, you can pre-read the next embroidery design using the barcode reader.



- You can pre-read only one design.
- If you read multiple barcodes during operation, the last design you read will be selected.
- When suspending embroidering a design during operation and setting the data of another design, the pre-read design will be deleted.
- When suspending embroidering a design during operation and to perform the data setting of the pre-read design, read the barcode again.

# 2. Deleting Designs

This section describes how to delete designs from the machine memory.

## 2-1. Deleting a design from the machine memory (one design at a time)

To delete one design at a time, use the following steps.



1 Press  on the main screen.

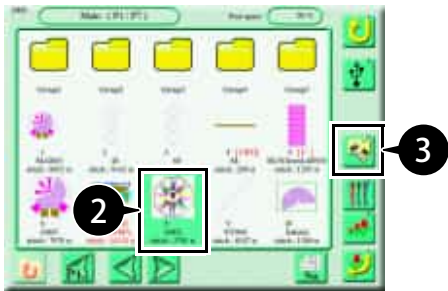

2 Select the design you want to delete.

3 Press .



- Press  to select all of the designs.

- Press  to deselect all of the designs.

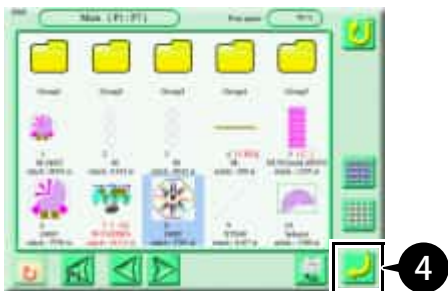

4 Press .



5 Press .



6 Press  .

The deletion is performed.



- If you delete the design whose data is set, you cannot continue embroidery.

## 2-2. Deleting designs from the machine memory (two or more designs at once)

To delete two or more designs at once, use the following steps.

The following example shows how to delete two selected designs at once.

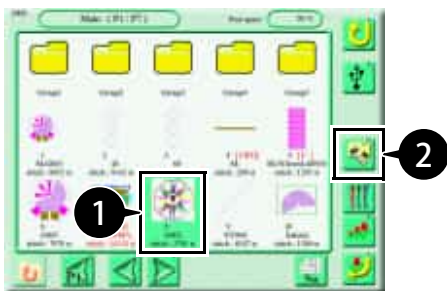

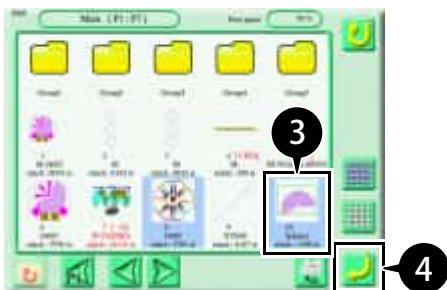

1 On the design selection screen, select the first design you want to delete.

2 Press  .



3 Select the second design you want to delete.



- Press  to select all of the designs.
- Press  to deselect all of the designs.

4 Press  .



5 Press  .



6 Press  .

The deletion is performed.



- If you delete the design whose data is set, you cannot continue embroidery.

### 2-3. Deleting designs from a USB memory

To delete designs in a USB memory, use the following steps.

The following example shows how to delete two selected designs.

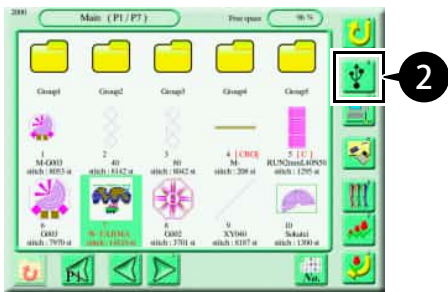

1 Insert a USB memory containing designs into the USB port on the operation panel.

2 Press  .

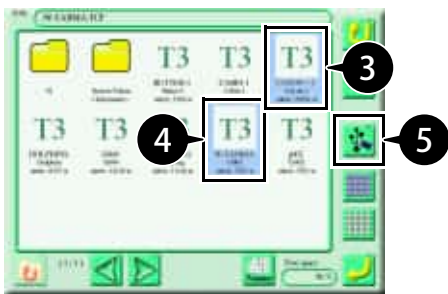

3 Select the first design you want to delete.



• Press  to select all of the designs.

• Press  to deselect all of the designs.

4 Select the second design you want to delete.

5 Press  .

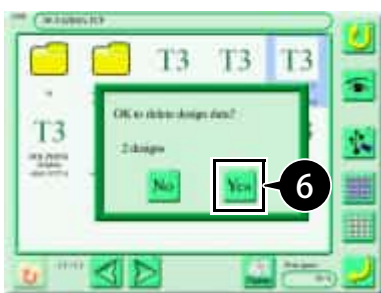

6 Press  .

The deletion is performed.

## 3. Changing a Design Name and a Storage Location

### 3-1. Changing a design name

To rename designs saved in the machine memory one by one, use the following steps.

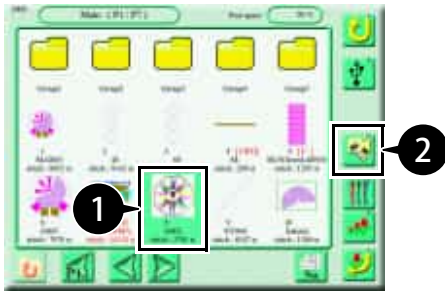

1 Select the design you want to rename on the design selection screen.

2 Press .

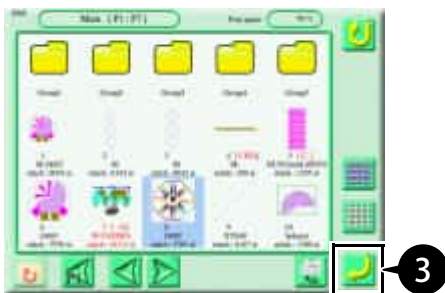

3 Press .



4 Press .

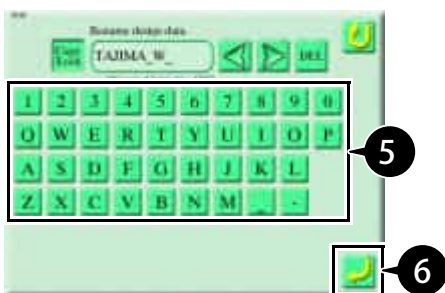

5 Enter the new design name.



- You can enter a design name up to 8 characters long.

6 Press .

The design is renamed.

### 3-2. Changing the design storage location

To move designs to a different storage location in the machine memory, use the following steps. The following example shows how to select two designs and move them to the "Group2" folder.

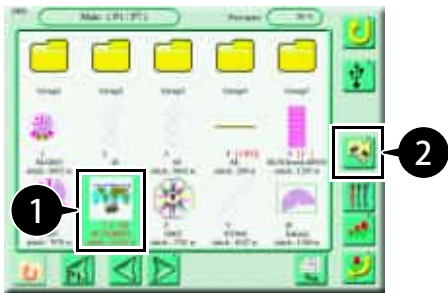



1 On the design selection screen, select the first design you want to move.

2 Press  .



3 Select the second design you want to move.



- Press  to select all of the designs.
- Press  to deselect all of the designs.

4 Press  .

5 Press  .



6 Press  "Group2".

The designs are saved in the "Group2" folder.

## Chapter 6

# Editing Needle Bar Steps and a Design

## 1. Editing Needle Bar Steps

You can individually change embroidery conditions (such as the needle bar No. and RPM) for each needle bar step.



- For items overlapping with the setting values of a machine parameter, the value here will take priority.

### 1-1. Setting needle bar step embroidery conditions

The following example shows how to change the embroidery conditions for needle bar step 5 by changing the needle bar No. from 1 to 9 and changing the RPM limit from 1200 rpm to 700 rpm.



1 Press  on the main screen.

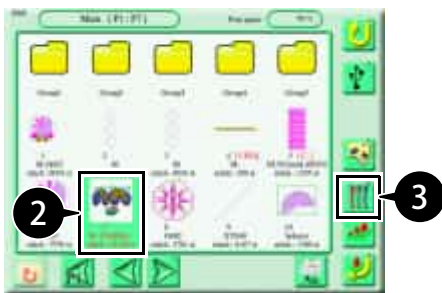

2 Select your desired design.

3 Press .

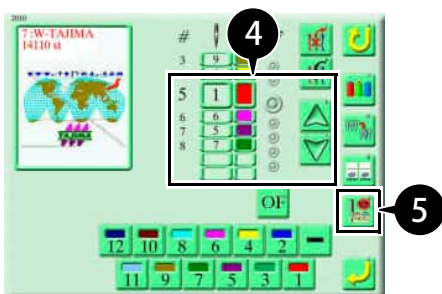

4 Press  to select needle bar step 5.

5 Press .



6 Press  and select needle bar No. 9.



7 Select "Speed limit".





8 Press  and select "700 rpm".

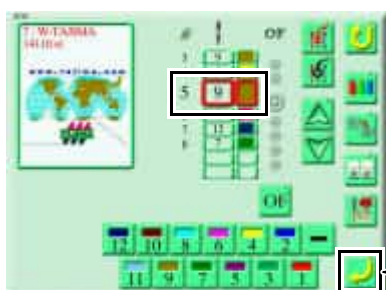

9 Press .  
The embroidery conditions are changed.

10 Press .



11 Press .  
The needle bar step whose embroidery conditions have been changed is highlighted in a red frame.

■ Details of the settings screen

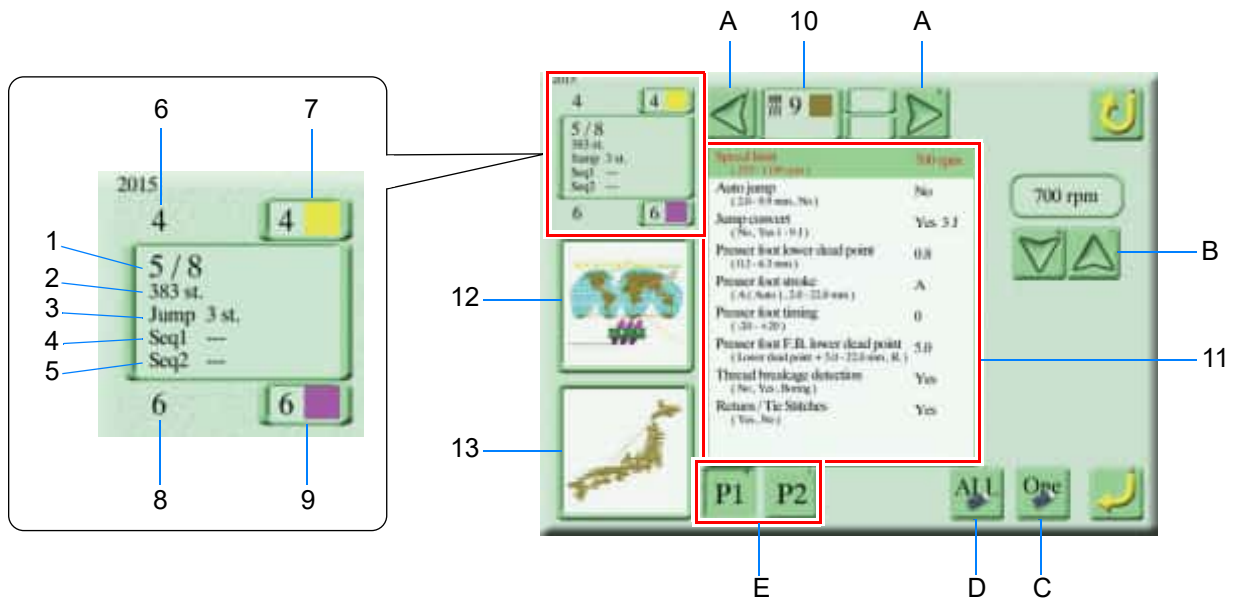

No.	Description	No.	Description
1	Currently selected step / Total number of steps in the design	10	Display of the needle bar No. and thread color for the currently selected step
2	Number of stitches in the step	11	Display of embroidery conditions (changed items are highlighted in red)
3	Number of jump codes in the step	12	Display of entire design
4	Number of sequin output 1 in the step	13	Enlarged view of the portions embroidered for the currently selected step
5	Number of sequin output 2 in the step	A	Change the needle bar No.
6	Previous step	B	Change the value
7	Display of the needle bar No. and thread color for the previous step	C	Initialize the value of the selected step's items.
8	Next step	D	Revert all items for the selected step to the initial value.
9	Display of the needle bar No. and thread color for the next step	E	Switch the screens (between P1 and P2)

**■ Embroidery condition items**

P1

Embroidery conditions	Setting range
Revolution Limit	250 rpm to Maximum rpm of machine
Auto Jump	2.0 to 9.9 mm, No
Jump Convert	No, Yes1 to 9J
Presser Foot Lower Dead Point	0.3 to 6.3
Presser Foot Stroke	A, 2.0 to 22.0
Presser Foot Timing	-20 to +20
Lower Dead Point for Presser Foot at F.B.	Lower dead point +5.0 to 22.0, R.
Thread Breakage Detection	No, Yes
Return / Tie Stitches	Yes, No

P2

Embroidery conditions	Setting range
Satin Stitch (Area) <sup>*1</sup>	Whole, part, No
Satin Stitch (Density) <sup>*1</sup>	0.4 to 1.0 mm
Satin Stitch (Expansion) <sup>*1</sup>	-1.0 to +1.0 mm
FS mode	Yes, No

\*1: Displayed only when the functional limit level is "SEL".

## 1-2. Insertion of a needle bar step

A new needle bar step is to be inserted after the specified needle bar step.

All the needle bar steps will follow the inserted one.

The following example shows how to insert a new needle bar step after needle bar step 4.

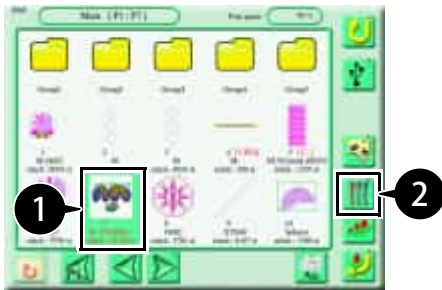

1 Select your desired design on the design selection screen.

2 Press .

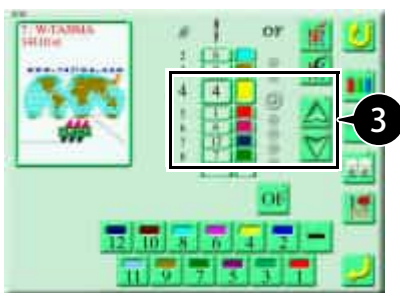

3 Press  to select needle bar step 4.

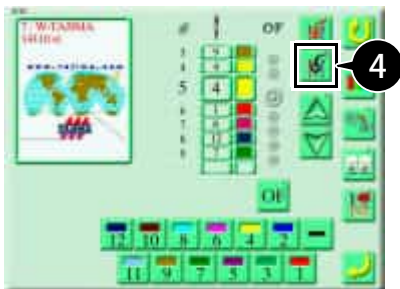

4 Press .

A new needle bar step is inserted.



- The inserted needle bar step is given the same needle bar No. as the one that precedes it. Change the needle bar No. as needed.

## 1-3. Deletion of a needle bar step

You can delete a specified needle bar step.

All the needle bar steps after the deleted one will move up.

The following example shows how to delete needle bar step 4.



1 Select your desired design on the design selection screen.

2 Press .

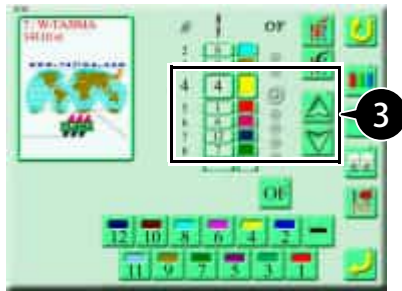

3 Press  to select needle bar step 4.

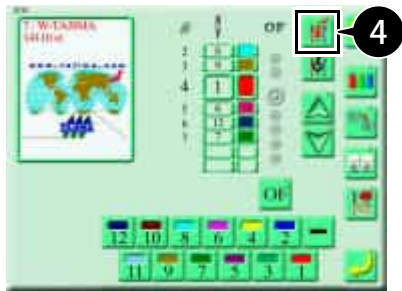

4 Press  .  
Needle bar step 4 is deleted.

### 1-4. Replacing the needle bar numbers all at one time

You can replace all the instances of a needle bar No. in the needle bar sequence with another needle bar No. all at one time.

Replacing a needle bar No. also changes the color of the design image displayed on the operation panel.

The following example shows how to replace the instances of needle bar No. 8 in the needle bar steps with needle bar No. 6 all at one time.

Before change			After change	
Needle bar step	Needle bar No.		Needle bar No.	
1	8	⇒	6	
2	5		5	
3	8	⇒	6	
4	5		5	
5	1		1	
6	8	⇒	6	

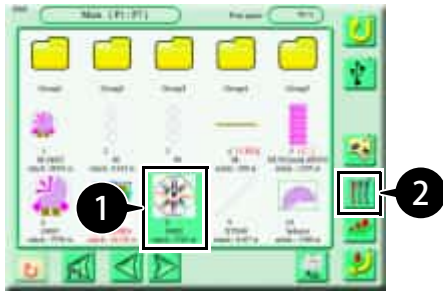

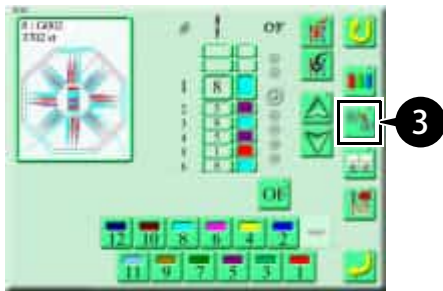

1 Select your desired design on the design selection screen.

2 Press .

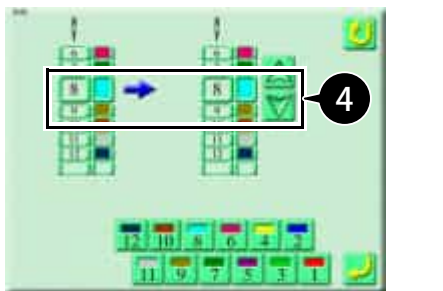

3 Press .



4 Press  and select needle bar No. 8.

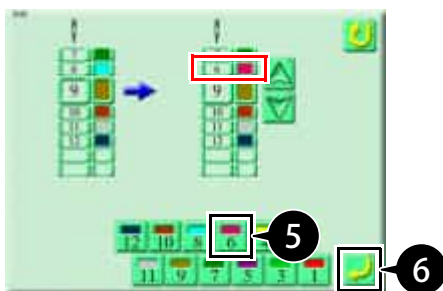

5 Press .  
Needle bar No. 8 is changed to No. 6 (highlighted in red).

6 Press .

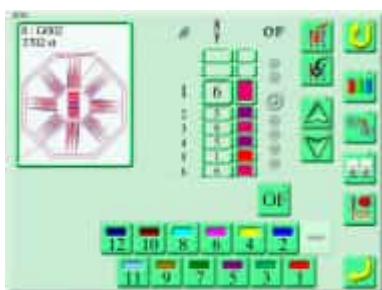

The specified needle bar Nos. are replaced all at one time.

1  
2  
3  
4  
5  
6  
7  
8  
9  
10

# 2. Needle Bar Management Function

## 2-1. Setting the needle bar thread color

You can change the thread color assigned to each needle bar.

Changing the thread color also changes the color of the design image displayed on the operation panel.

The following example shows how to change needle bar numbers 1 and 5 to yellow and black, respectively.

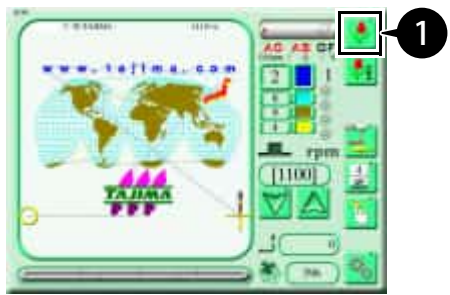

1 Press  on the main screen.



2 Select the design you want to change.

3 Press .

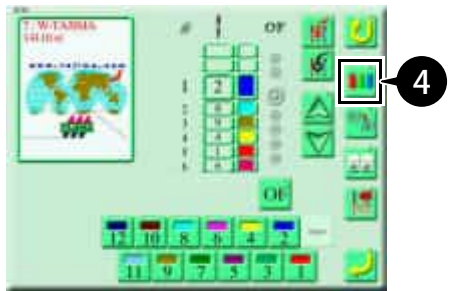

4 Press .

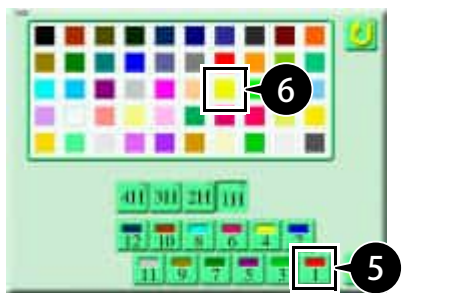

5 Press .

Needle bar No. 1 is selected.

6 Select yellow from the color palette.  
The thread color of needle bar No. 1 changes to yellow.

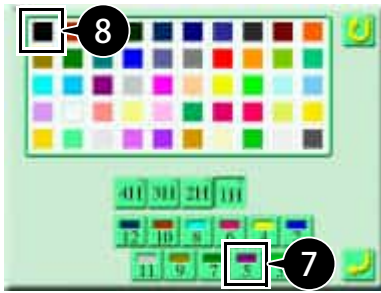

7 Press  .  
Needle bar No. 5 is selected.

8 Select black from the color palette.  
The thread color of needle bar No. 5 changes to black.



9 Press  .  
The specified thread colors are set.

1

2

3

4

5

6

7

8

9

10

# 3. Editing a Design

## 3-1. Copying a design

Before you divide a design, you should copy the design in the machine memory so that the original design will be maintained. You can specify a folder in the "main" layer and each folder in the machine memory as the copying destination. You can copy as many designs as you like.

The following example shows how to select two designs and copy them into the "Group2" folder.



1 Press  on the main screen.

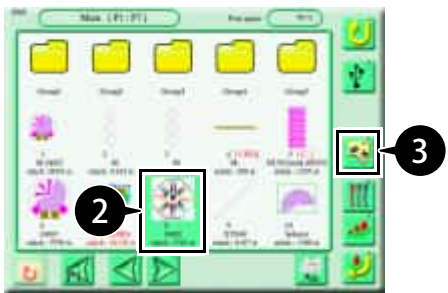

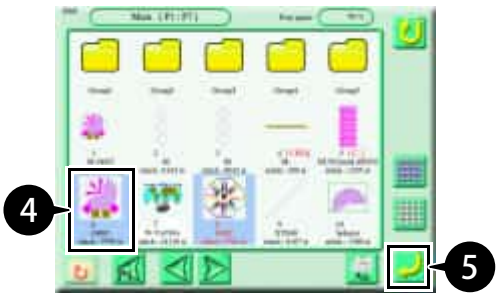

2 Select the 1st design you want to copy.

3 Press .



4 Select the 2nd design.



- Press  to select all of the designs.
- Press  to deselect all of the designs.

5 Press .  
The design is selected.



6 Press .



7 Press  "Group2".

The designs are copied into the "Group2" folder.

## 3-2. Dividing a design

You can divide a design before and after your specified stitch No. Note that the first divided design will include all of the stitches prior to the specified stitch No.

The following example shows how to search for a design by Color Change function code and divide it before and after your specified stitch.



- This operation divides the original design. Copy the design in advance as needed.

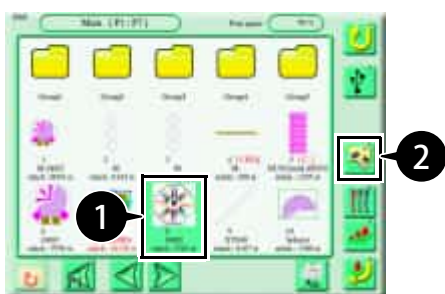

1 Select the design you want to divide on the design selection screen.

2 Press .



3 Press .  
The design is selected.



4 Press .

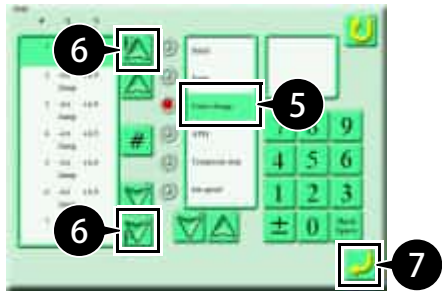

5 Select "Color change".

6 Start search.



: Stitches before the selected stitch will be searched.



: Stitches after the selected stitch will be searched.

Stitches that include the selected function code will be searched in order.



- For details on how to search stitches, refer to "Chapter 6 6-1. Search by stitch No.".

7 Press .

8 Press .

The design is divided.



- The following example shows how to divide design No. 8 in the machine memory and save them as No. 8 and No. 155.

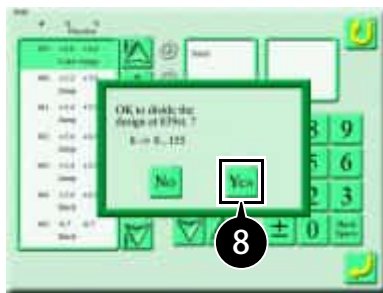

### 3-3. Combining designs

You can combine multiple designs into a new design and save it in the same layer in the machine memory. The following example shows how to combine three designs.

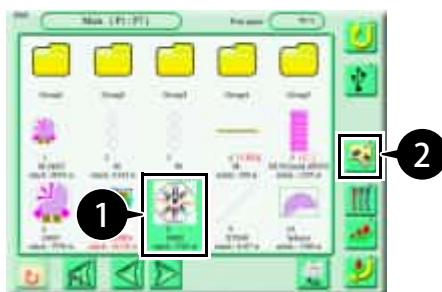

1 On the design selection screen, select the first design you want to combine.

2 Press .

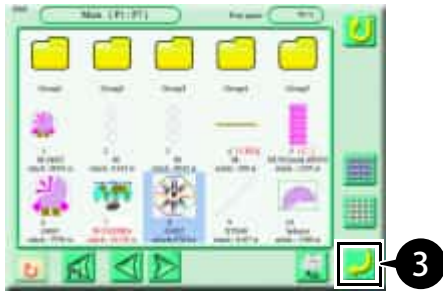

- 3 Press  .  
The 1st design is selected.



- 4 Press  .

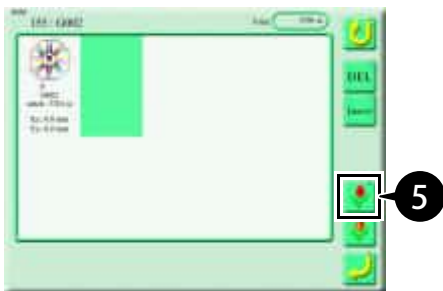

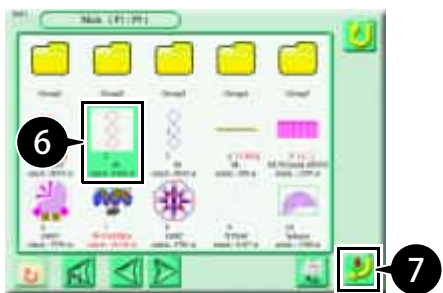

- 5 Press  .



- 6 Select the 2nd design.

- 7 Press  .  
The 2nd design is selected.



- To change the 2nd or 3rd design, select the design you wish to change and press  to select another design.
- Press  to delete the design.
- Press  to insert the design.
- If you only want to combine two designs, proceed to step 12.

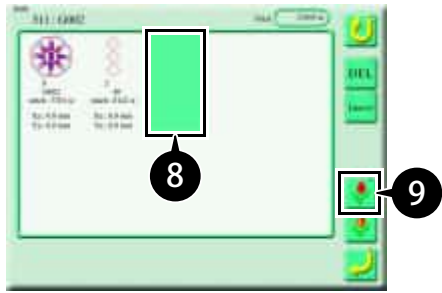

8 Press on the side of the 2nd design.  
A (green) space for a 3rd design is created.

9 Press  .

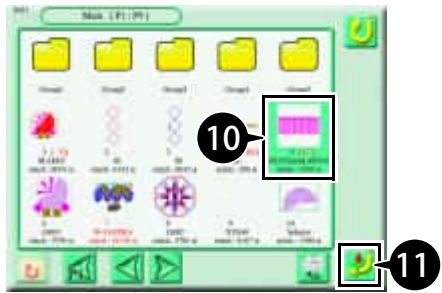

10 Select the 3rd design.

11 Press  .  
The 3rd design is selected.

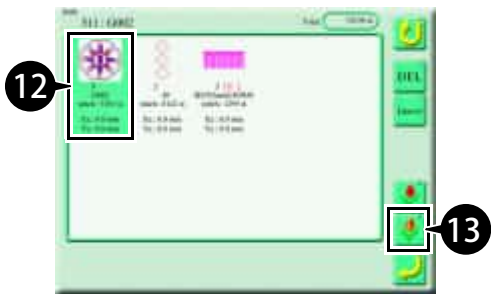

12 Select the 1st design.

13 Press  .

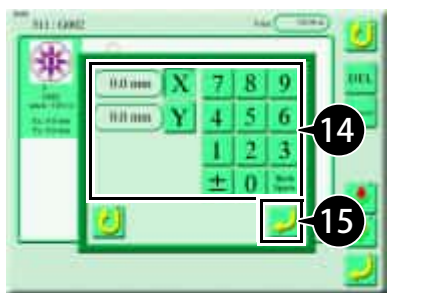

14 Enter the start position (X and Y coordinates) of the 1st design.



- You cannot use the Frame Travel key to enter the start position.

15 Press  .  
The start position is set.

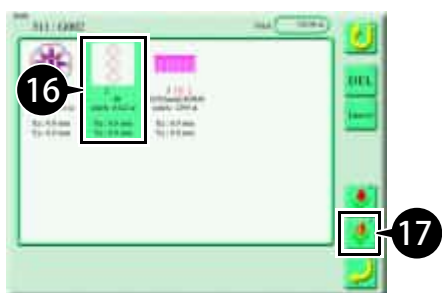

16 Select the 2nd design.

17 Press  .

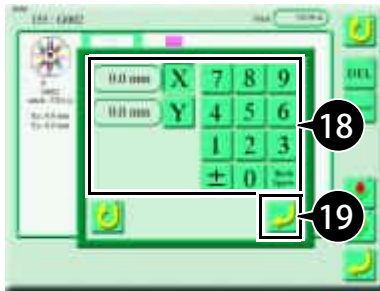

18 Enter the start position (X and Y coordinates) of the 2nd design.

19 Press .

The start position is set.



- If you only want to combine two designs, proceed to step 24.

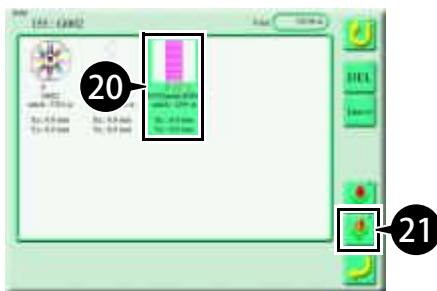

20 Select the 3rd design.

21 Press .

22 Enter the start position (X and Y coordinates) of the 3rd design.

23 Press .

The start position is set.

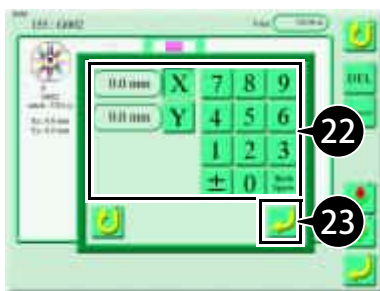

24 Press .

The designs are combined.

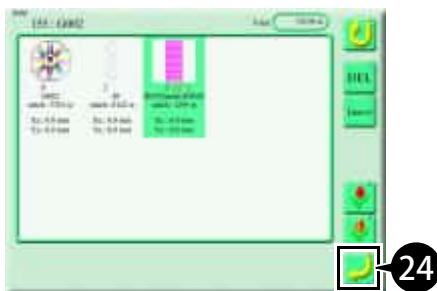

1

2

3

4

5

6

7

8

9

10

# 4. Design Layout

## 4-1. Scaling up/down a design

You can enlarge/reduce your specified design. You can also enlarge/reduce a design at different ratios for the Y (vertical) and X (horizontal) axes.

Example: Y (vertical)/X (horizontal) enlargement to 150%

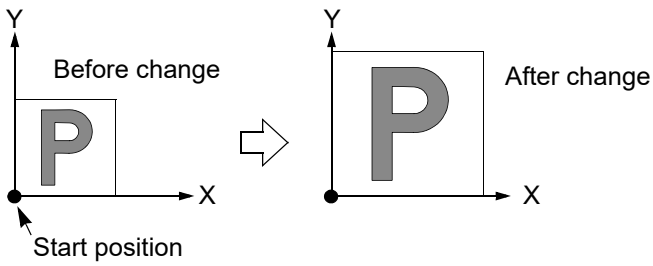

1 Press  on the main screen.



2 Select your desired design.

3 Press .



4 Press .





5 Enter the X (horizontal) ratio (for example, 150%). The Y ratio field is automatically filled in with the same value.



6 Press  .

Your specified ratio value is set.



- To configure a Y (vertical) ratio different than the X (horizontal) ratio, press  and enter your desired Y (vertical) ratio. Then press  .

## 4-2. Rotating a design

You can rotate your specified design clockwise in 45° or 1° increments.

### ■ To rotate a design by 45°

Example: Rotation by 45°

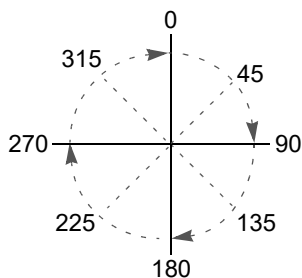
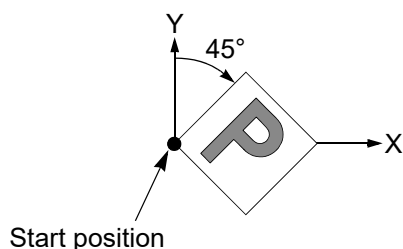

1 Select your desired design on the design selection screen.

2 Press  .



3 Press the rotation angle (for example,  for 45°).



- 4 Press  .  
Your specified rotation angle value is set.

**■ To rotate a design in 1° increments**

Example: Rotation by 5°

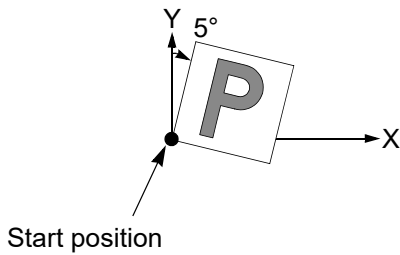

- 1 Select your desired design on the design selection screen.
- 2 Press  .



- 3 Press  .



- 4 Enter the rotation angle (for example, "5").
- 5 Press  .  
Your specified rotation angle value is set.

### 4-3. Reversing a design

You can reverse your specified design horizontally.

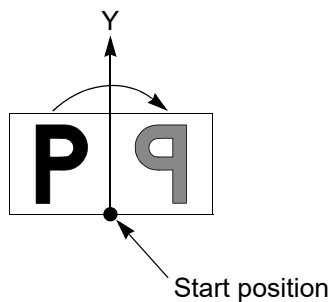

1 Select your desired design on the design selection screen.

2 Press .



3 Press .

The display changes every time you press the button.

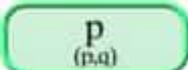
 : Do not reverse

 : Reverse



4 Press .

The design is reversed.

1

2

3

4

5

6

7

8

9

10

# 5. Settings for Repetition

You can repeat your specified design.

If the design is enlarged/reduced or rotated/reversed, the changed shape is repeatedly placed.

## 5-1. Repeating a design by specifying the number of repetitions

You can repeat a design by specifying the number of repetitions and the vertical and horizontal distances.

Example:

- Repeat 3 times horizontally at a distance of 50 mm
- Repeat 2 times vertically at a distance of 60 mm
- Priority direction: Horizontal

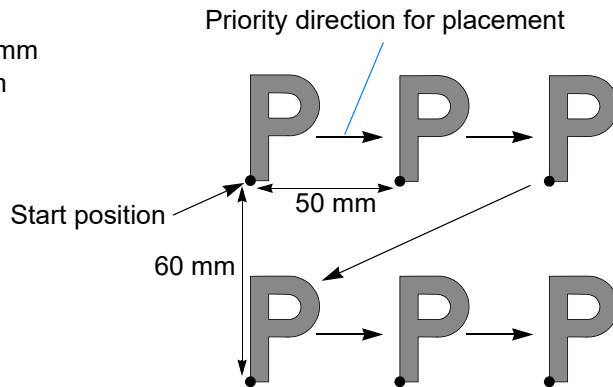

1 Press  on the main screen.



2 Select your desired design.

3 Press .

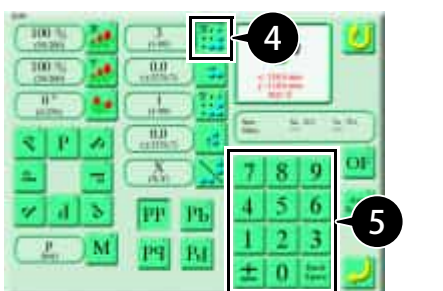

4 Press .



5 Enter the horizontal number of repetitions (for example, "3").





6 Press .

7 Enter the horizontal distance (for example, "+50.0").

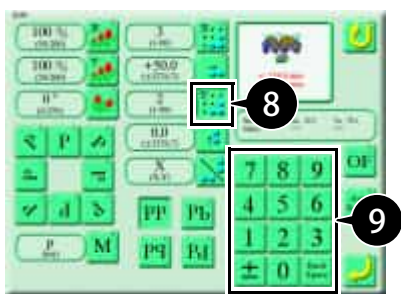

- To repeat on the right side, press  to select [+].
- To repeat on the left side, press  to select [-].



8 Press .

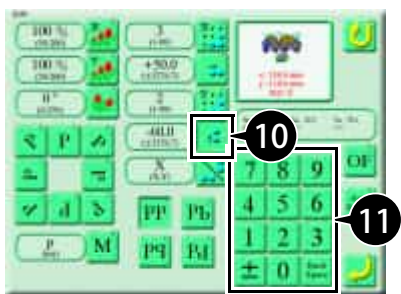

9 Enter the vertical number of repetitions (for example, "2").



10 Press .

11 Enter the vertical distance (for example, "-60.0").



- To repeat on the upper side, press  to select [+].
- To repeat on the lower side, press  to select [-].



12 Press .

Your specified number of repetitions is set.



- The X (horizontal)/Y (vertical) scale changes every time you press .

## 5-2. Repeating a design by automatically calculating the number of repetitions

You can repeat a design by specifying the distance and automatically calculating the number of designs that can be placed in the embroidery space.

Example:

- Horizontal distance: 50 mm
- Vertical distance: 60 mm
- Placement position: Center

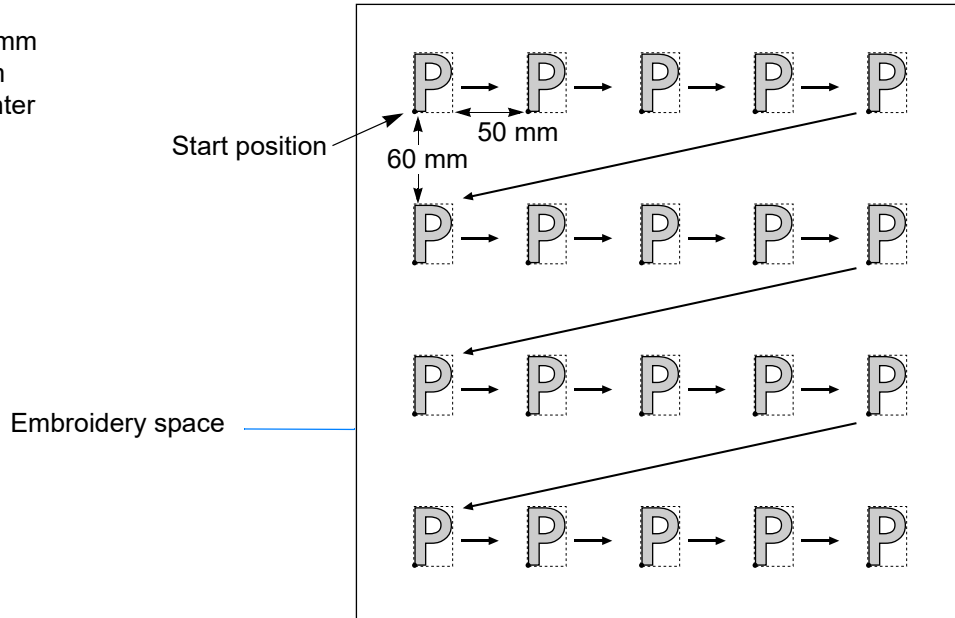

1 Select your desired design on the design selection screen.

2 Press .



3 Press .



4 Enter the horizontal distance (for example, "50.0").

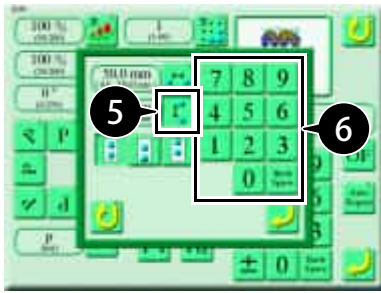

5 Press  .

6 Enter the vertical distance (for example, "60.0").

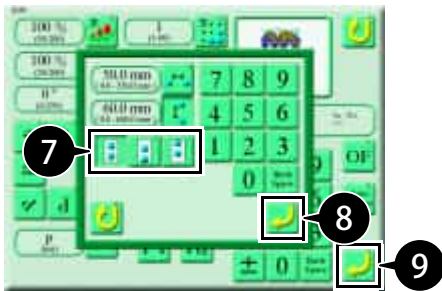

7 Select the placement method.



: Place in the center



: Place from the front side



: Place from the rear side

8 Press  .

The number of repetitions is automatically calculated.

9 Press  .

Auto repeat is set.

1

2

3

4

5

6

7

8

9

10

### 5-3. Reversing or rotating a design alternately

You can place the design by reversing or rotating alternately at the odd numbered times and the even numbered times.

Reverse based on X-axis

Example: **Pb** (Vertical priority)

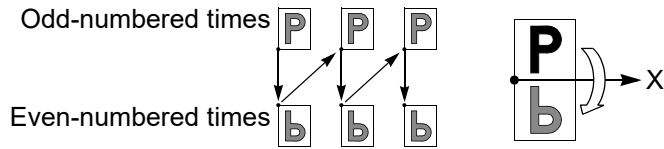

Reverse based on Y-axis

Example: **Pq** (Vertical priority)

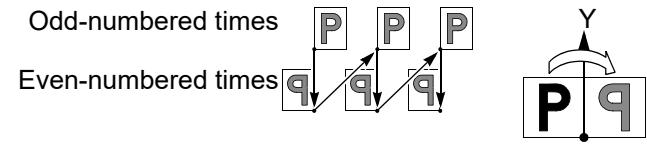

180° rotation

Example: **Pd** (Vertical priority)

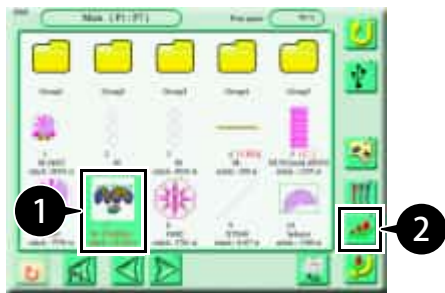
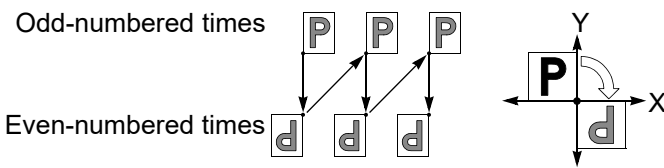

1 Select your desired design on the design selection screen.

2 Press  .



3 Configure the X (horizontal) and Y (vertical) numbers of repetitions, distances, and priority directions.

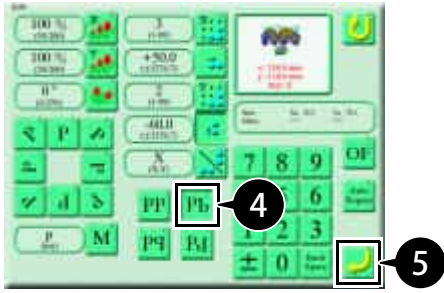

For this setting

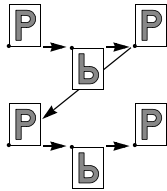

4 Select the method of placement (whether to reverse or rotate them).

 : Reverse based on X-axis

 : Reverse based on Y-axis

 : Rotate 180°

5 Press .

The placement method is set.

- 1
- 2
- 3
- 4
- 5
- 6
- 7
- 8
- 9
- 10

## 6. Editing Stitches

You can search for stitch data (hereinafter "stitches") of designs saved in the machine memory.



- To change stitches, enter the password to set the functional limit level to "SEL".

### 6-1. Search by stitch No.



1 Press  on the main screen.

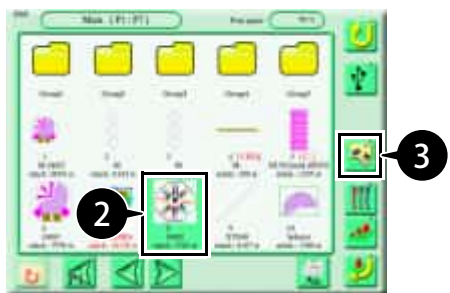

2 Select your desired design.

3 Press .



4 Press .  
The design is selected.



5 Press .

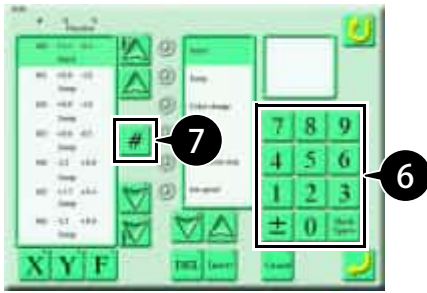

6 Enter your desired stitch No. (for example, "480").

7 Press .

The entered stitch No. is displayed.

## 6-2. Search by function code

You can select more than one function code to search for stitch data.

For more information on the function codes, operations, and details, see the table below.

Function code	Movement	Detail
Stitch	Stitches will be sewn.	
Jump	Jumping will be performed. (Frame travel while needle bar is idle)	
Color change	Stop and color change will be performed.	
ATH	Upper thread or upper/under threads will be trimmed automatically.	Upper thread *1, upper/under threads
Temporary stop	Temporary stop will be performed at stitch or jump.	Stitch, jump
Low speed	A low speed operation will be performed in the specified stitch section.	Start S, end S Start J, end J
Satin stitch	Satin stitch conversion will be performed in the specified section.	Start, end
Automatic free-setting offset	Frame travel will be performed according to the setting of the automatic offset.	
Sequin	The sequin device will work in the specified section.	Start, end, Output 1, output 2
ATH prohibited	Thread trimming will not be performed in the specified stitch section.	Start S, end S Start J, end J
Seed beads	The seed beads device will work in the specified section.	Start, end, Output 1, output 2
AFC frame feed	Open and close the AFC frame valve to perform the fabric feed operation.	

\*1: The machine trims upper/under threads even if "Upper thread" is selected.

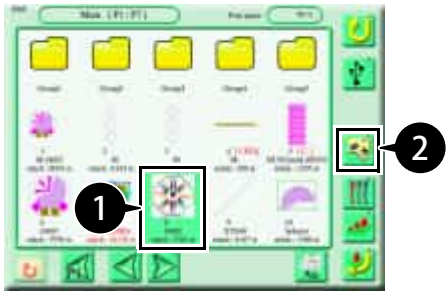

1 Select your desired design on the design selection screen.

2 Press  .

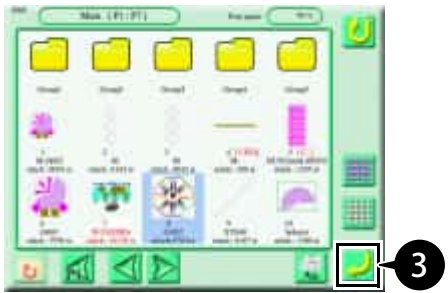

3 Press  .  
The design is selected.



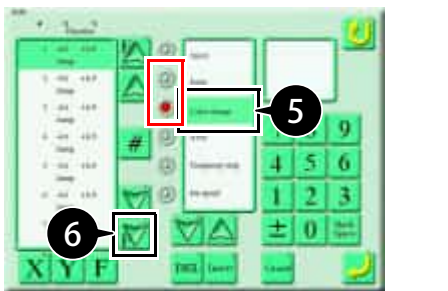

4 Press  .

5 Select a function code (for example, "Color change").  
The radio buttons to the left of the code are lit in red.



6 Start search.

 : Stitches before the selected stitch will be searched.

 : Stitches after the selected stitch will be searched.

Stitches that include the selected function code will be searched in order.

### 6-3. Modification of a stitch

You can change the function code of your specified stitch.



- This operation overwrites the original design. Copy the design in advance as needed.
- If an embroidery stitch after the change differs in length from the embroidery stitch before the change, all of the subsequent stitches in the design will be displaced.



- To change stitches, enter the password to set the functional limit level to "SEL".



1 Press  on the main screen.

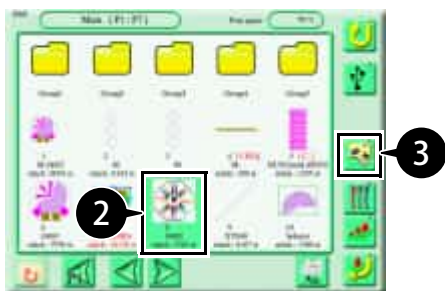

2 Select your desired design.

3 Press .

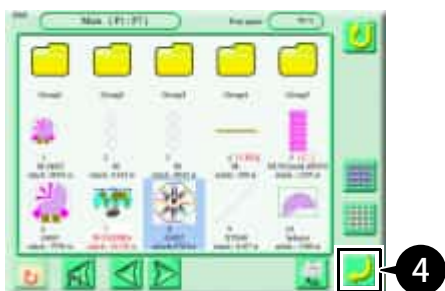

4 Press .  
The design is selected.



5 Press .

1  
2  
3  
4  
5  
6  
7  
8  
9  
10

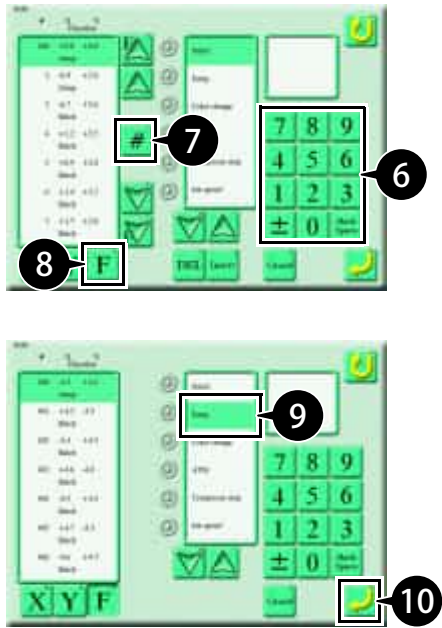

6 Enter the stitch No. (for example, "480") for which you want to change the function code.

7 Press  .

8 Press  .

9 Select a function code (for example, "Jump").

10 Press  .

The function code is changed.

### 6-4. Insertion of a stitch

You can insert a new stitch before the selected stitch.



- This operation overwrites the original design. Copy the design in advance as needed.
- Inserting a stitch with a length displaces all the subsequent stitches in the design.



- To insert a stitch, enter the password to set the functional limit level to "SEL".

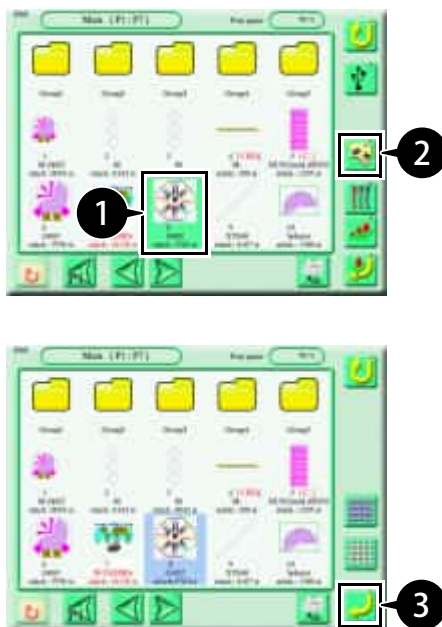

1 Select your desired design on the design selection screen.

2 Press  .

3 Press  .

The design is selected.



4 Press  .

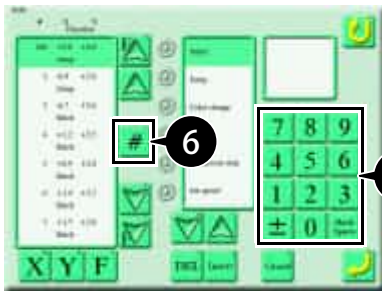

5 Enter the stitch No. for the new stitch you want to insert (for example, "480").

6 Press  .

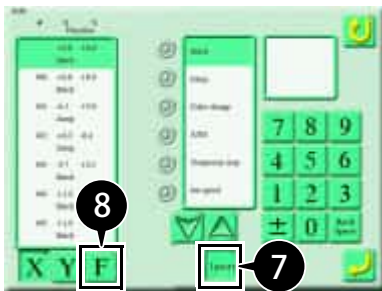

7 Press  .

8 Press  .

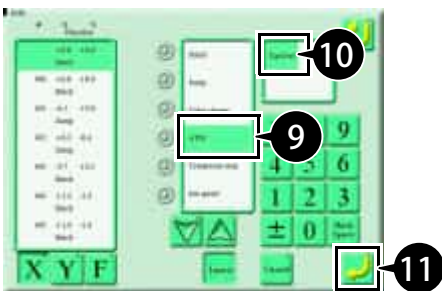

9 Select a function code (for example, "ATH").

10 Select a thread trimming method (for example, "Up/Und").

11 Press  .

A new stitch is inserted.

1

2

3

4

5

6

7

8

9

10

## 6-5. Deletion of a stitch

You can delete your specified stitch.



- This operation overwrites the original design. Copy the design in advance as needed.
- Deleting a stitch with a length displaces all the subsequent stitches in the design.



- To delete a stitch, enter the password to set the functional limit level to "SEL".

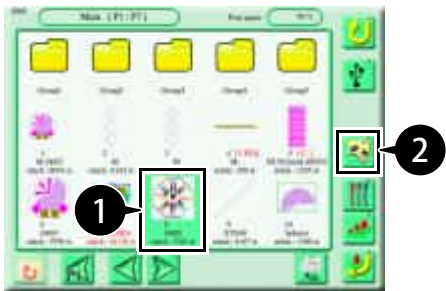

1 Select your desired design on the design selection screen.

2 Press  .



3 Press  .  
The design is selected.



4 Press  .

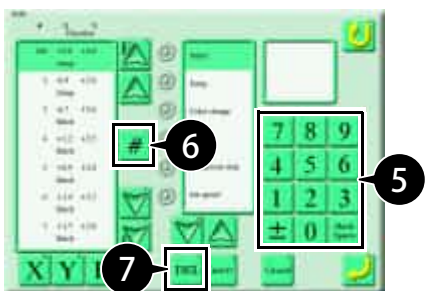

5 Enter the stitch No. of the stitch you want to delete (for example, "480").

6 Press  .

7 Press  .

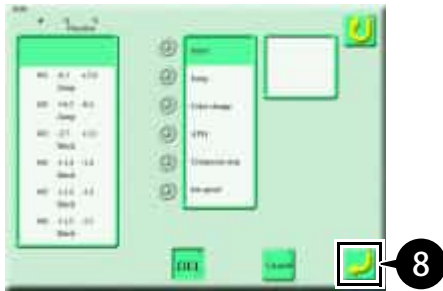

8 Press .

Your specified stitch is deleted.

## 6-6. Removal of tiny stitches

You can remove tiny stitches by merging them into the previous and next stitches.

This feature can reduce thread cast-offs and thread breakages.

If the designs are on the same screen, you can process multiple designs at once.

The following example shows how to remove 0.5 mm and smaller stitches by selecting two designs.



- This operation overwrites the original design. Copy the design in advance as needed.

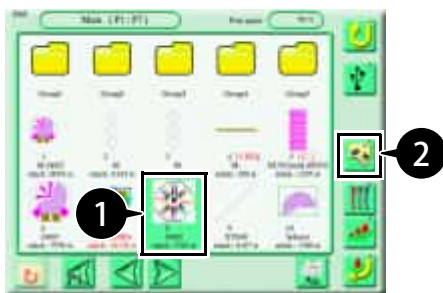

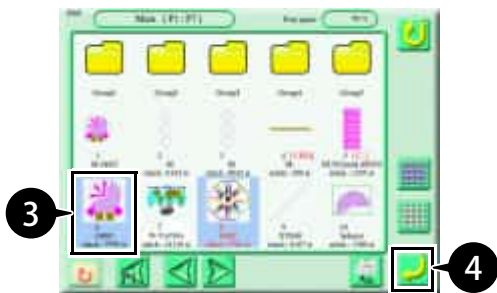

1 Select your desired design (the 1st design) on the design selection screen.

2 Press .



3 Select the 2nd design.



- Press  to select all of the designs.
- Press  to deselect all of the designs.

4 Press .

The design is selected.

1

2

3

4

5

6

7

8

9

10



5 Press  .

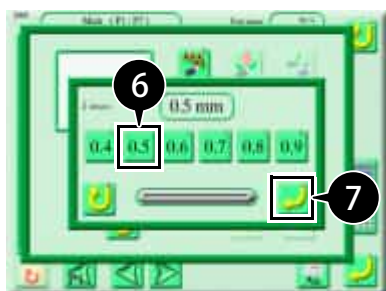

6 Press  .



- If you select one design and press  , the number of stitches to be removed is displayed.



7 Press  .

8 Press  .

0.5 mm and smaller stitches are removed.

# Chapter 7

## Various Functions

### 1. Offset Frame Travel

#### 1-1. Function outline

To make it easy to exchange the frame or fabric, set an applique fabric, and check the embroidery finish, you can automatically move the frame to an arbitrary position (where work is easier) after or during embroidery.

To use this feature, register the position for where the frame should move to (hereinafter the "offset position") in advance.

Select any of the following three types of offset frame travel according to the timing of use.

#### ■ Automatic Offset

Move the frame to the offset position upon completion of embroidery.

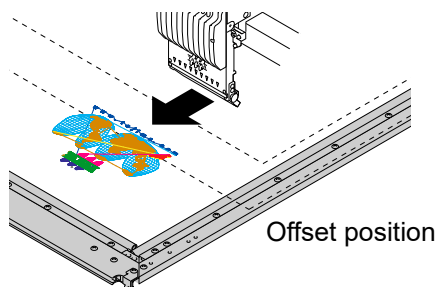

The frame moves to the offset position upon completion of embroidery.

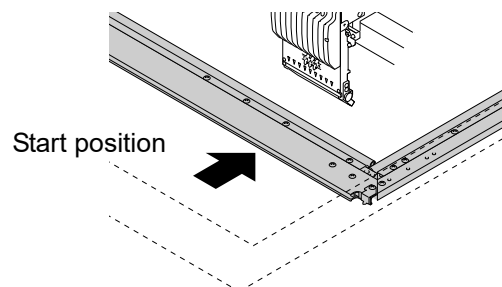

Once you replace the fabric and start the machine, the frame automatically moves to the start position and embroidery starts.

#### [If you have registered the offset middle position]

The frame moves via the offset middle position to the offset position upon completion of embroidery.

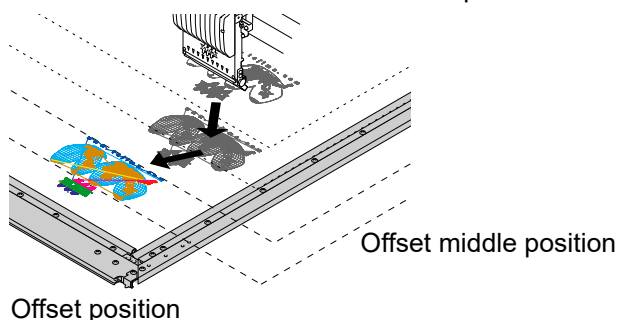

Offset position



- Registering an offset middle position also allows you to move the frame to avoid the head while placing an applique fabric.
- You can register two offset points (one middle and one offset point).

### ■ Automatic free-setting offset

You can stop the machine at your specified stitch position and move the frame to the offset position. Moving the frame to the front side makes it easy to set an applique fabric, for example.

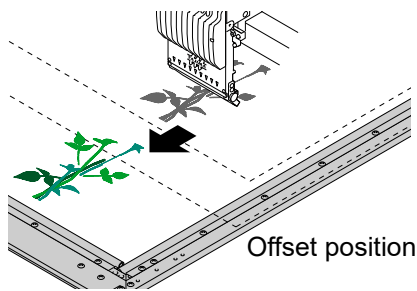

The frame automatically moves to the offset position during embroidery.

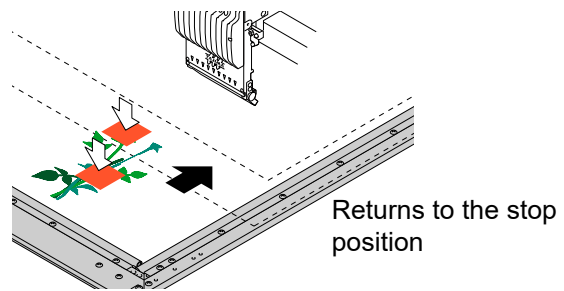

The frame automatically returns to the stop position and resumes embroidery once the machine starts after placing the applique fabric.

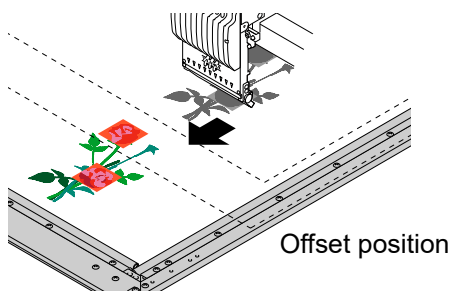

The frame automatically moves to the offset position upon completion of embroidery.



- Register the offset position in advance.
- The frame moves to the offset position during and after embroidery.

### ■ Automatic color change offset

You can stop the machine at the color change position and move the frame to the offset position. Moving the frame to the front side makes it easy to set an applique fabric, for example.

The frame moves in the same manner as that for an automatic free-setting offset.

## 1-2. Registering the offset position

You have to register an offset position on a design by design basis.

The following example shows how to register the start position, the offset middle position (OF1), and the offset position (OF2).

### Caution



Do not put your hands on the table when you operate the machine. Failure to observe this may result in injury due to frame travel.



- The offset position is registered for each design. You do not need to register it again the next time you embroider the same design.

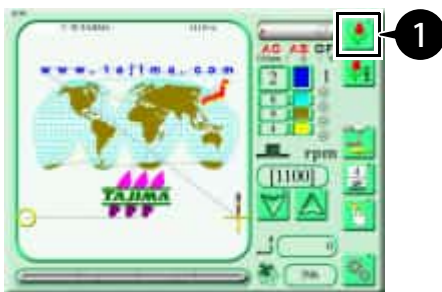

1 Press  on the main screen.



2 Select your desired design.

3 Press .



4 Press .

The offset settings screen appears.

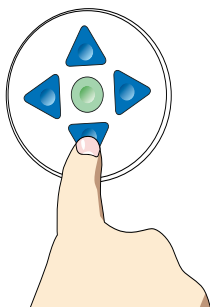

● Start position

5 Using the frame travel key, move the frame to the start position.

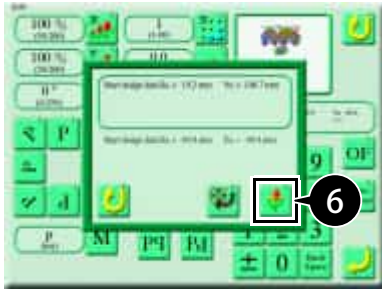

6 Press  .

The current frame position is set as the start position.



- You can move the frame to the start position of the design by pressing  when the current position is set as the start position.

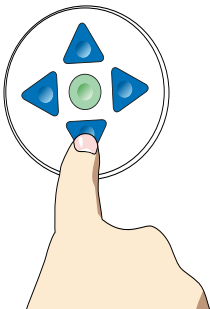

Start position  
Offset middle position

7 Using the frame travel key, move the frame to the offset middle position.



- If you do not want to register the offset middle position, proceed to step 8.

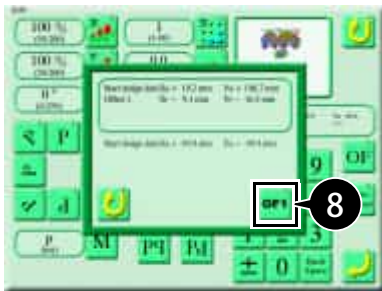

8 Press  .

The current frame position is set as the offset middle position.

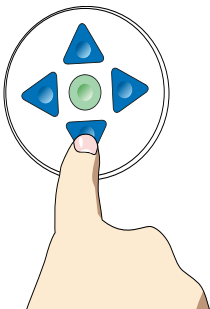

Start position  
Offset middle position  
Offset position

9 Using the frame travel key, move the frame to the offset position.

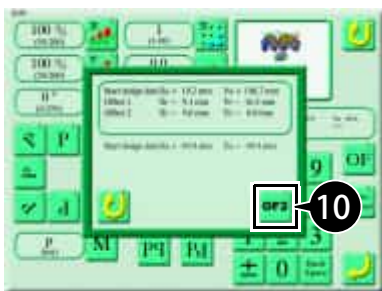

10 Press  .

The current frame position is set as the offset position.



- 11 Press  .  
Each position is registered.

### 1-3. Erasing the offset position

#### Caution

 Do not put your hands on the table when you operate the machine. Failure to observe this may result in injury due to frame travel.



- 1 Select your desired design on the design selection screen.

- 2 Press  .



- 3 Press  .



- 4 Press  .

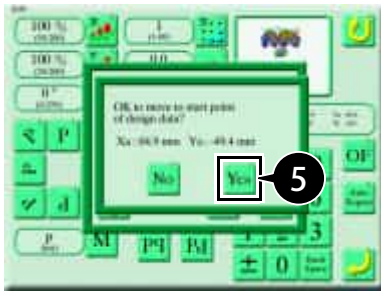

5 Press  .  
The frame moves to the start position.

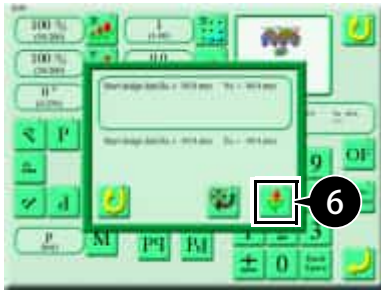

6 Press  .

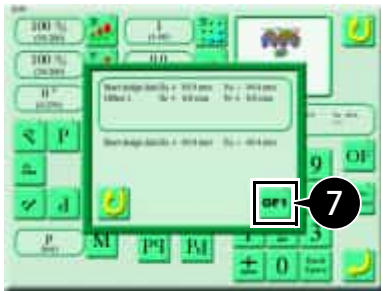

7 Press  .



8 Press  .  
If the design's start position and offset 1 are set to the same position, the offset position is deleted.

## 1-4. Moving the frame by selecting a specific stitch

The following example shows how to insert an automatic free-setting offset code at the 480th stitch.



- To use this feature, enter the password to set the functional limit level to "SEL".
- Register the offset position in advance.



1 Select your desired design on the design selection screen.

2 Press .

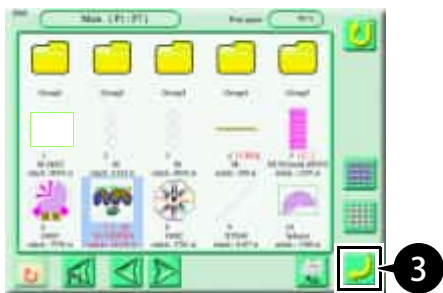

3 Press .  
The design is selected.



4 Press .

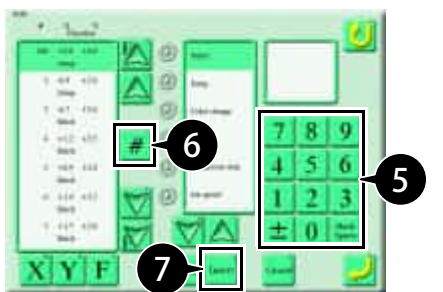

5 Enter "480".

6 Press .

7 Press .

1

2

3

4

5

6

7

8

9

10

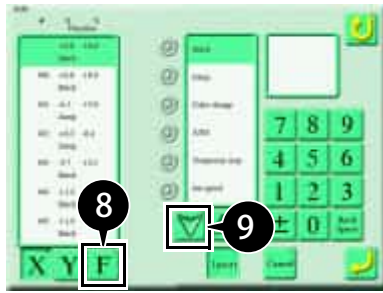

8 Press  .

9 Press  .

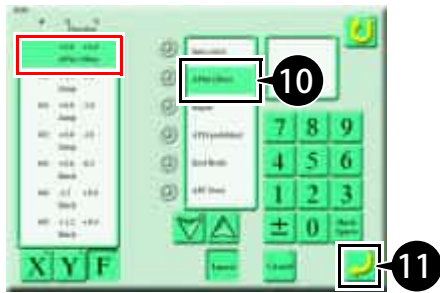

10 Select "AFSet Offset".  
An automatic free-setting offset code (in the red box) appears at the 480th stitch.

11 Press  .  
An automatic free-setting offset code is inserted.

## 1-5. Moving the frame using the color change sequence

The following example shows how to add an offset (OF) between the needle bar steps 4 and 5.





- Register the offset position in advance.

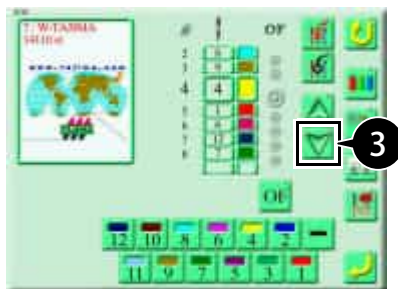

1 Select your desired design on the design selection screen.

2 Press  .



3 Press  to select needle bar step 4.

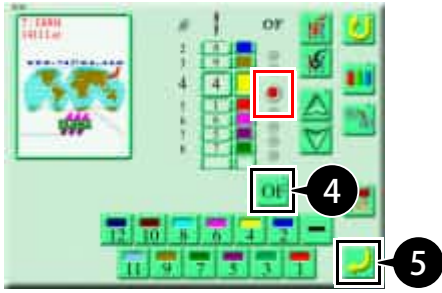

4 Press .

The automatic color change, offset radio button (OF) is lit in red.

5 Press .

An automatic color change offset is added.

1

2

3

4

5

6

7

8

9

10

# 2. Selecting Active Heads

## 2-1. Outline of function

You can select and activate particular heads.

This feature allows you to activate only the odd- or even-numbered heads or specify the heads you want to activate for each needle bar step.

### ■ Activating only the odd- or even-numbered heads

Odd-numbered heads only

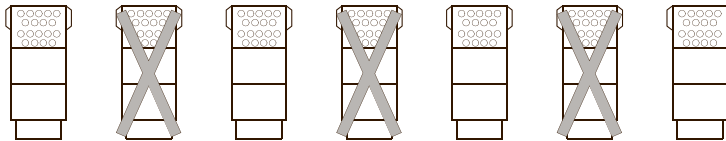

Even-numbered heads only

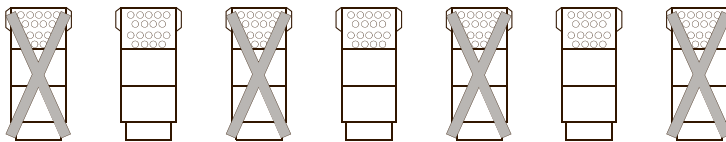

### ■ Specifying active heads for each needle bar step

You can register patterns of active heads in advance and specify active heads for each needle bar step.

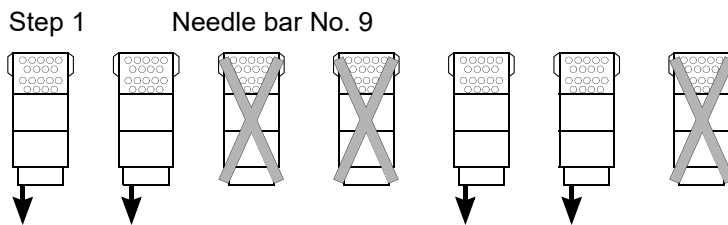

↓ The arrows show the needle bars used for embroidery.

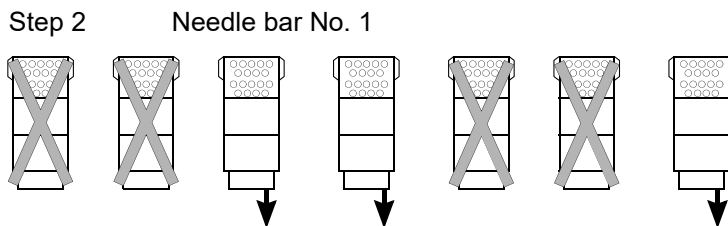

- You can register up to 20 patterns.

## 2-2. Activating only the odd- or even-numbered heads



1 Press  on the main screen.

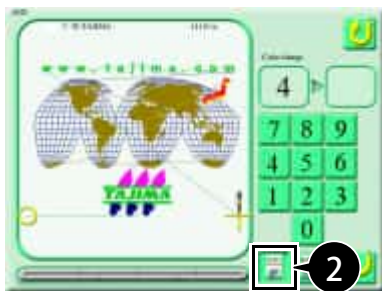

2 Select active heads.



: Activate odd-numbered heads only



: Activate even-numbered heads only



: Activate all heads



3 Press .

Only the selected heads are activated.

## 2-3. Specifying active heads for each needle bar step

### ■ Registering patterns of active heads

You can register combinations of active heads as patterns.

The following example shows how to register patterns under the conditions shown below:

Pattern No.	Active head number
P1	2, 4, 6, 8, 10, 12, 14, 16, 18, 20
P2	1, 3, 4, 6, 7, 9, 10, 12, 13, 15, 16, 18, 19

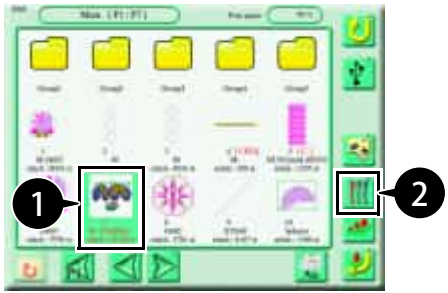

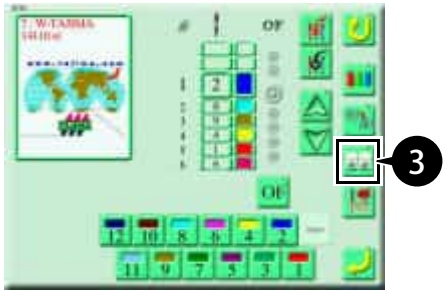

1 Select your desired design on the design selection screen.

2 Press  .

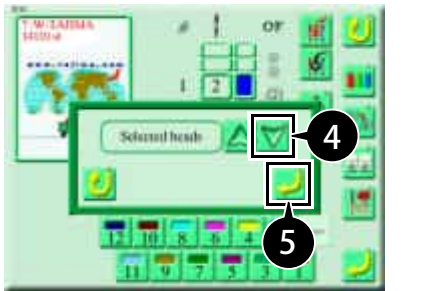

3 Press  .



4 Press  and select "Selected heads".

5 Press  .

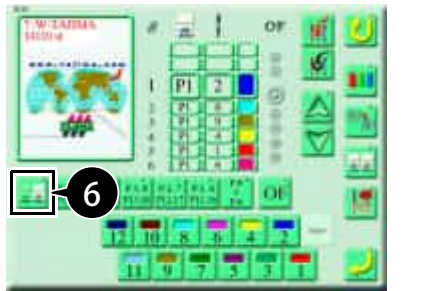

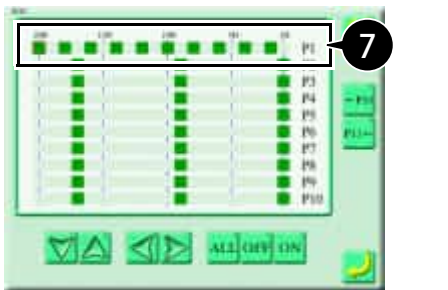

6 Press  .



7 Activate (green) only the head number 2, 4, 6, 8, ...20 for P1.

 : Select or deselect all

 :  Suspended head.

 :  Active head



8 Activate (green) only the head number 1, 3, 4, 6, 7, ...19 for P2.

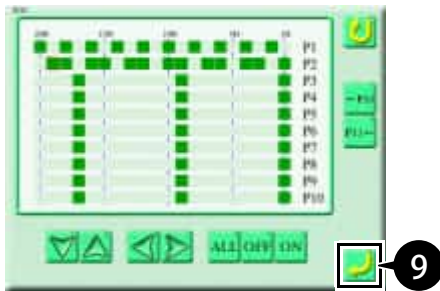

9 Press .

The patterns of active heads are registered.

### ■ Registering the patterns for each needle bar step

You can set the pattern numbers for each needle bar step. This allows you to automatically change the active and suspended heads for each needle bar step.

The following example shows how to register pattern numbers for each needle bar step under the conditions shown below:

Needle bar step	Pattern No. Numbers in ( ) mean active heads
1	P6 (1, 2, 5, 6, 9 ...)
2	P2 (1, 3, 4, 6, 7 ...)



- This setting is registered for each design. You do not need to register it again the next time you embroider the design.



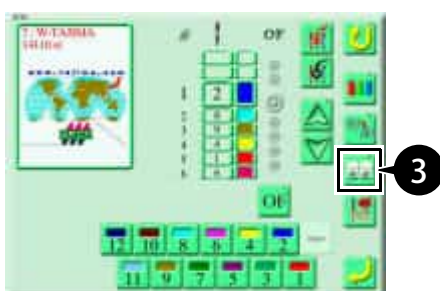

1 Select your desired design on the design selection screen.

2 Press .



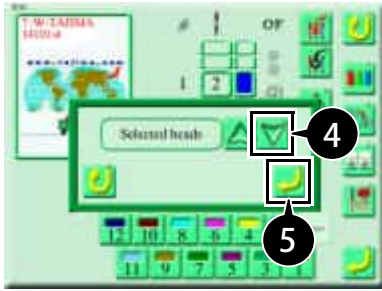

3 Press .

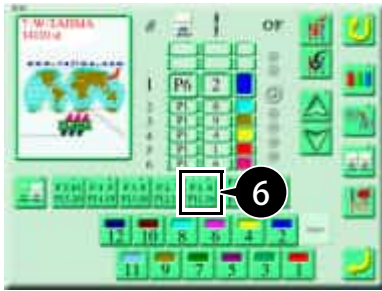

4 Press  and select "Selected heads".

5 Press .





6 Press  twice.

P6 is set for needle bar step 1.

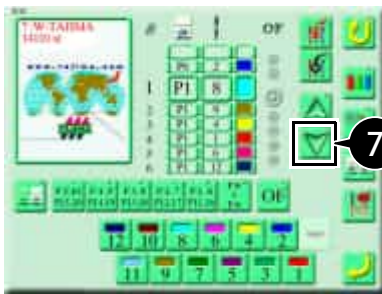

- To set the same pattern as the previous step, press



7 Press  to select the needle bar step 2.

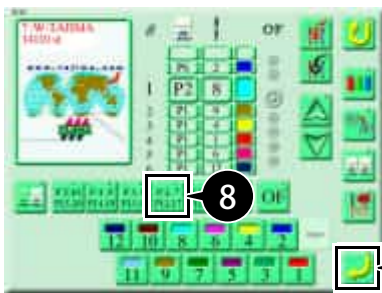

8 Press  three times.

P2 is set for needle bar step 2.

9 Press .

Each needle bar step is configured with the active head patterns.

## 3. Grouping Heads

### 3-1. Outline of function

You can group up to four heads to create a head group. This allows you to embroider a color scheme that exceeds the number of needles per one head or a large design that exceeds the embroidery space.



- The maximum number of colors available with a head group differs depending on the number of needles of the machine and the frame specifications.

Head group types		Description
All heads		Embroidery with an ordinary single head.
2H		Embroidery of one design by two adjacent heads grouped into one.
3H		Embroidery of one design by three adjacent heads grouped into one.
4H		Embroidery of one design by four adjacent heads grouped into one.
TE2H (All heads+two heads)		Embroidery of one design per head by two adjacent heads grouped into one.

### 3-2. Examples of making use of head groups

**■ Embroidering a design with a color scheme that exceeds the number of needles per one head**

You can use a head group to embroider a design with a color scheme that exceeds the number of needles per one head. For example, when you are using a nine-needle machine, you can use a group of two heads (2H) to embroider a design with up to 18 colors (if the frame spec. is D [Double]).

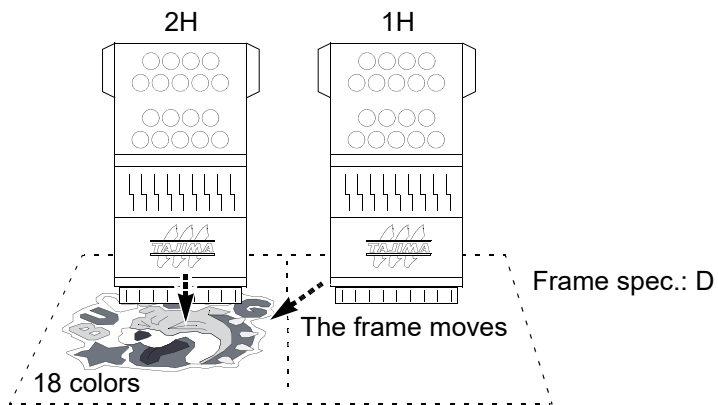

The frame moves to the right (the space of the first head) after the machine embroiders step 1 by needle bar No. 9 (yellow) of the second head, then the machine embroiders step 2 by needle bar No. 1 (purple) of the first head.

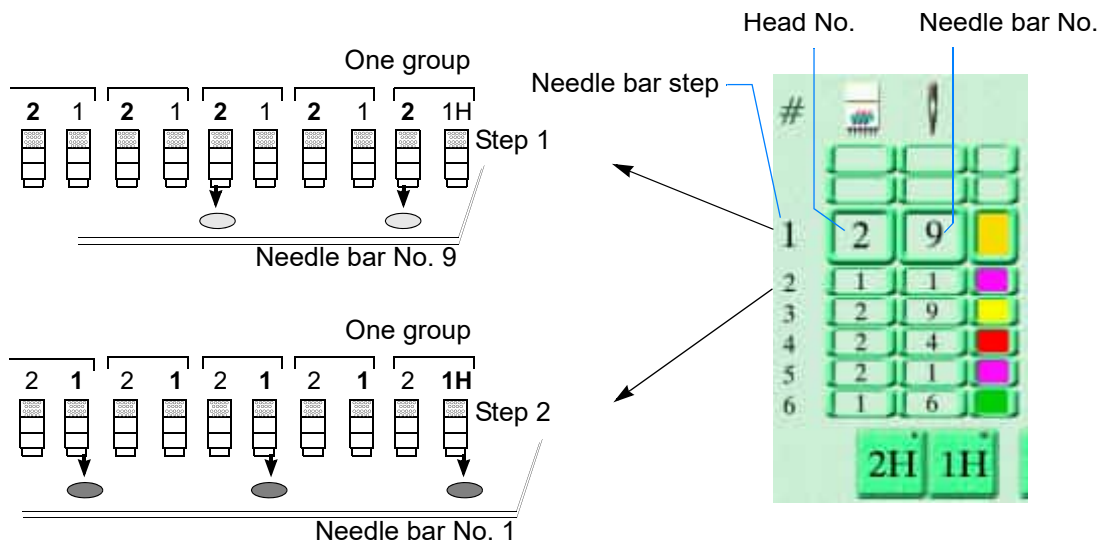

**■ Embroidering one design in an embroidery space of multiple heads**

You can use a head group to embroider a design with an embroidery space larger than supported by one head. For example, you can create a group of two heads (2H) to embroider step 1 with the 1st head (1H) and step 2 with the 2nd head (2H), respectively. (If the frame spec. is S [Single].)

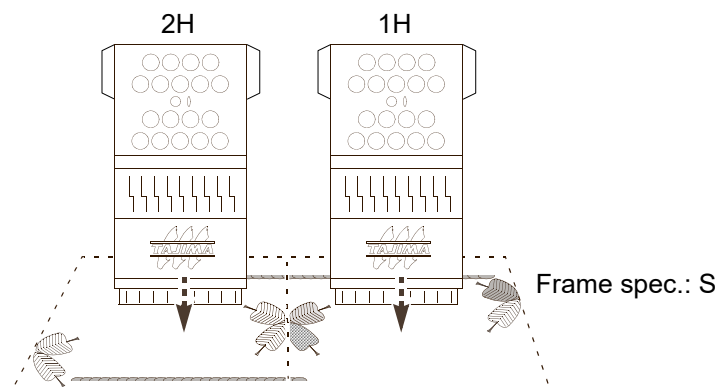

### A more advanced example (TE2H)

You can use a head group to embroider a design that combines all heads and 2H groups.

"TE2H" is available only if the machine's frame spec. is T, Q, TE, or T2E.



- If the frame spec. is T or Q, one or more last heads may not be able to perform embroidery (depending on the number of heads).



- The head offset is fixed to (and thus cannot be changed from) "H.OF YES Frame step".

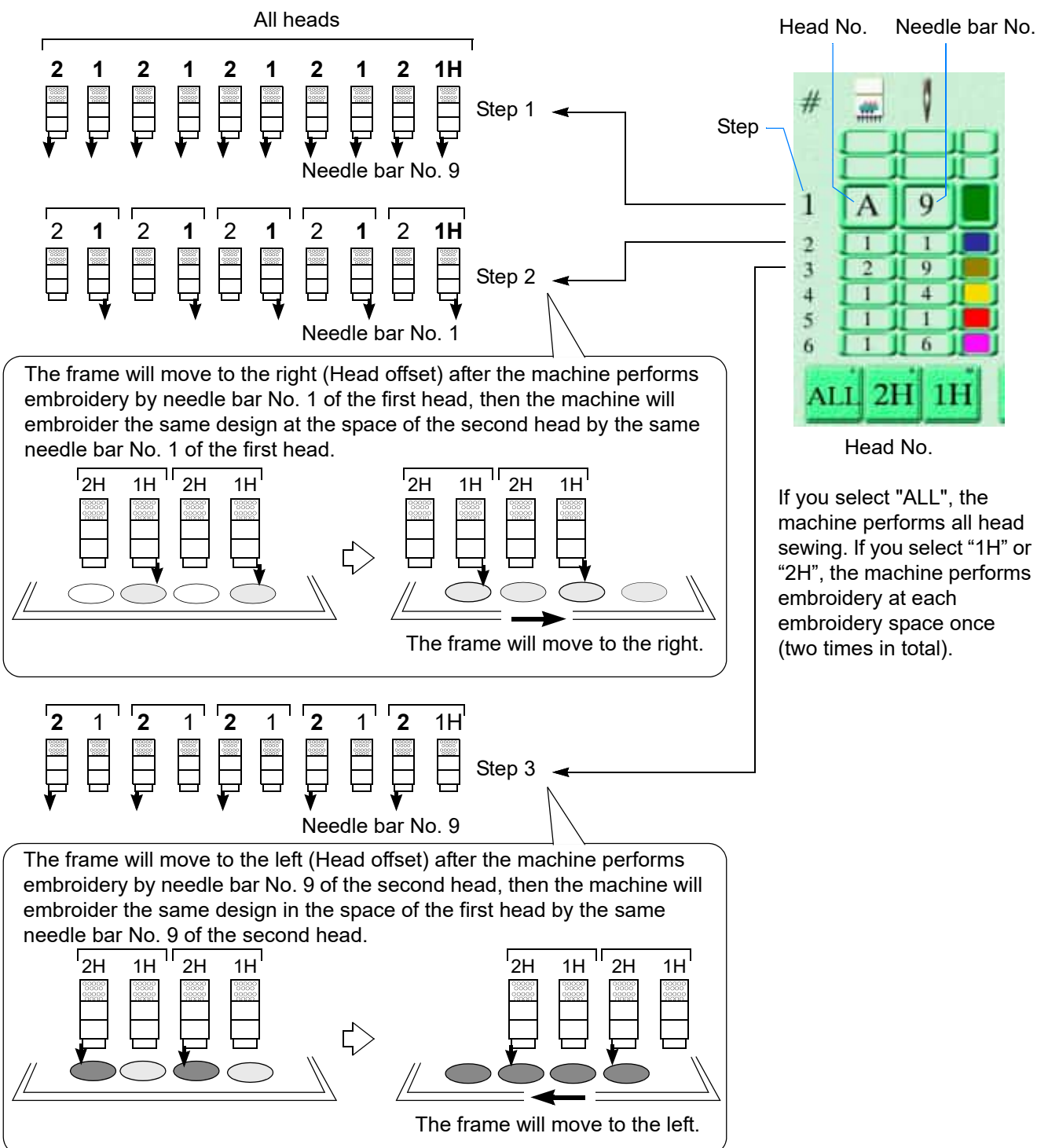

### 3-3. Grouping heads and editing needle bar steps

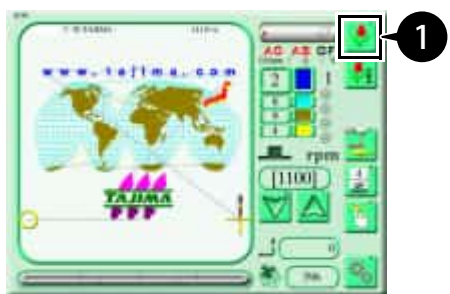

1 Press  on the main screen.



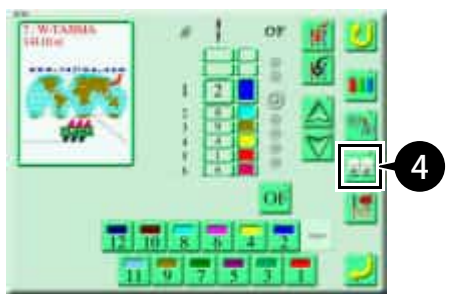

2 Select your desired design.

3 Press .



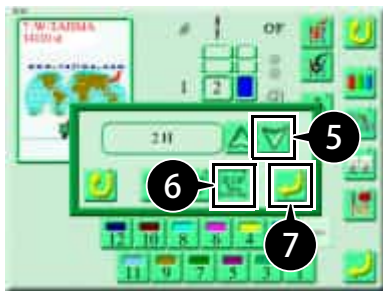

4 Press .





5 Press  and select the number of heads you want to group (for example, 2H).

6 Press .



- The frame spec. determines whether or not the icons , , and  are displayed and available for selection.

-  : Head offset is not performed.
-  : When the sewing head changes, the frame will move automatically to the next head position.
-  : When the sewing head changes, the frame will move automatically to the next head position with the frame stepping (recommended).

7 Press .

8 Select the head for needle bar step 1 (for example, 1H).  
The first head is selected.

9 Select a needle bar No. (for example, 4) of needle bar step 1.

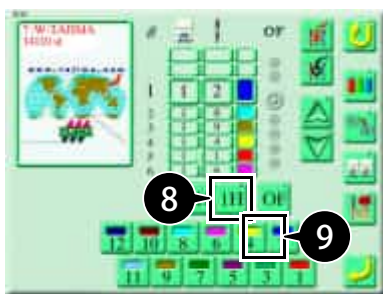

10 Select the head for needle bar step 2 (for example, 2H).  
The second head is selected.

11 Select a needle bar No. (for example, 6) of needle bar step 2.  
Configure needle bar steps 3 and later.

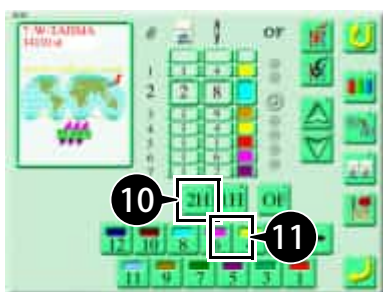

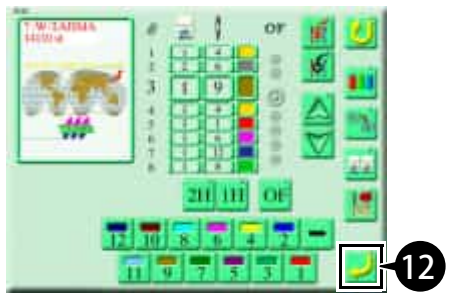

12 Press  .

Multiple heads are grouped.









## 4. Marking

### 4-1. Function outline

Before you perform applique embroidery or placement embroidery, you can create basting data (marking design) to help to correctly place the material.

There are two types of marking designs: "Point" and "Contour". "Points" are used to manually create marking designs. "Contours" are used to automatically mark the contours of designs.

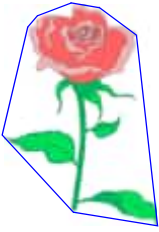
Marking is available in the following combinations. Use the combination that best suits your requirement.

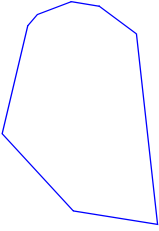
Marking Design	With or without design	Embroidery image	Description
Point 	With design 		Register the point and design in the machine memory.* 1
	Without design 		Register only the point in the machine memory.
Contour 	With design 		Register the contour and design in the machine memory.* 1
	Without design 		Register only the contour in the machine memory.

\*1: If selecting "With design", an automatic free-setting offset code is automatically added to the end of the marking design. If you register an offset position, the frame automatically moves to the offset position after the marking design is completed.

For details, refer to "Chapter 7 1. Offset Frame Travel".

## 4-2. Creating a marking design

The following example shows how to set the marking type as "Point", create a marking "With design", and set the stitch length to "5.0 mm".



- Once you create a marking design, it is automatically registered as "M-" in a free number on the design selection screen.
- If you set the marking type as "Contour", skip steps 10 to 15 and proceed to step 16 because marking is automatically created.

### ⚠ Caution



Do not put your hands on the table when you operate the machine. Failure to observe this may result in injury due to frame travel.



1 Press  on the main screen.



2 Select your desired design.

3 Press .



4 Press .



5 Press .

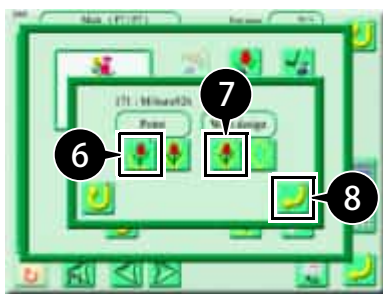

6 Press  .

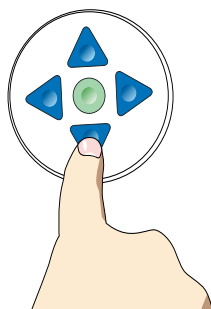

7 Press  .

8 Press  .



9 Using the frame travel keys, move the frame to the start position of the design.



- You can specify up to 10 marking points.
- You can also move the frame to the start position of the design by pressing  and  .

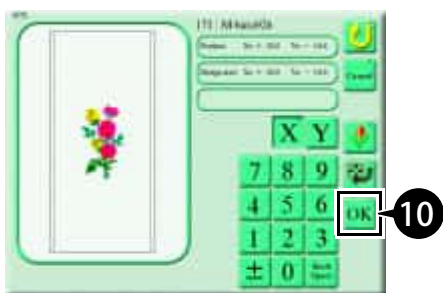

10 Press  .

The start position of the design is set.

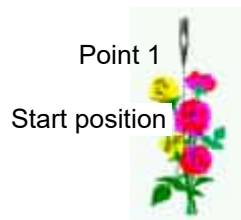
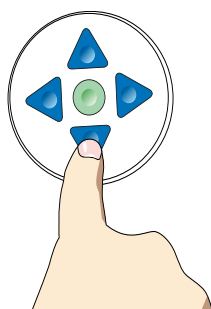

11 Move the frame to point 1 by pressing the frame travel key.



- Enter the coordinates for point 1 (based on the start position) using numeric keys and press  and



to move the frame.

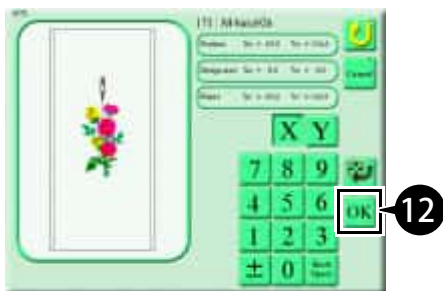

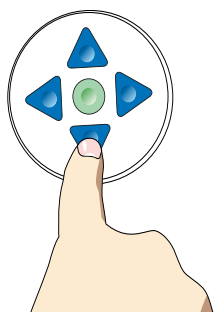

12 Press  .

Point 1 is registered.



13 Move the frame to the point 2 by pressing the frame travel keys.



- Enter the coordinates for point 2 (based on point 1) using numeric keys and press  and  to move the frame.

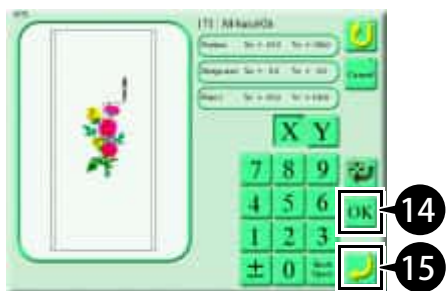

14 Press .

Point 2 is registered.



- Once you register two or more points, a new marking design is automatically registered.

15 Press .

The points have been set. Numerical keys for setting the stitch length are displayed.

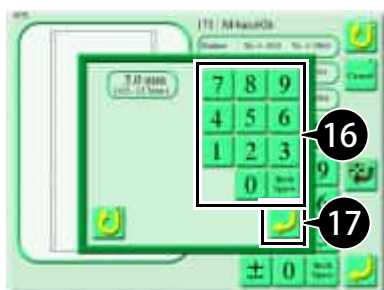

16 Enter "50".

17 Press .





The marking design is registered.

# Chapter 8



# Maintenance

## 1. Maintenance Precautions

### Warning

-  Be sufficiently trained and instructed on how to perform maintenance work such as lubrication and adjustment before actually doing so.
-  Greasing, inspection of drive systems, and repair of the machine must be performed by your distributor or service personnel assigned and trained by TAJIMA. Failure to observe this may result in injury, electric shock, or other serious accidents.
-  Ensure safety by turning OFF the machine power and removing the power plug from the outlet before starting maintenance work.
-  Upon completion of maintenance work, re-install all the covers you removed. Running the machine with covers removed may result in something getting caught in moving parts.

### Caution

-  Perform maintenance work periodically. Lack of maintenance may result in early deterioration or failure of parts. Damage arising from lack of maintenance may be excluded from warranty replacement.
-  If the machine will not be used for a long period, turn ON the power switch in regular intervals. Although each card of the machine has a backup battery, data may be lost in about one month because voltage of the battery gradually dissipates due to discharge when the power switch is turned OFF.
-  When you work underneath the machine table, ensure sufficient lighting.

## 2. Maintenance Item List

Daily maintenance and inspection are important to prevent machine trouble.

Use the following maintenance and inspection items for maintenance schedules, etc.

### ■ Maintenance and inspection items

Frequency	Parts	Maintenance and inspection content
Once per 5 to 6 hours	Rotary hook	Lubrication
Every day	Inside of the cylinder bed	Cleaning
Once/week	Head and its surroundings	Cleaning
	Inside of head	Lubrication
	Drive system	Cleaning
	Presser foot shaft	Cleaning
Once every three months	Inside of head	Greasing
	Each belt in main shaft drive system	Periodic inspection
	X- and Y-axis drive belts	Periodic inspection
	Rotating, sliding section	Periodic inspection
Once every six months	Cylinder bed gear	Greasing

## 3. Cleaning

Clean accumulated lint and dust, using a commercially available cleaning tool, an air gun, and the supplied brush.

### 3-1. Inside the rotary hook base

Frequency: Every day

#### ■ Manually operating the ATH (automatic thread trimming and holding device)

Open the movable knife of the ATH before cleaning, using the operation panel.

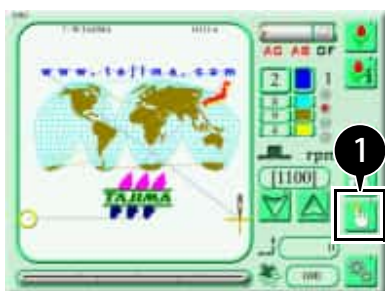

1 Press  on the main screen.

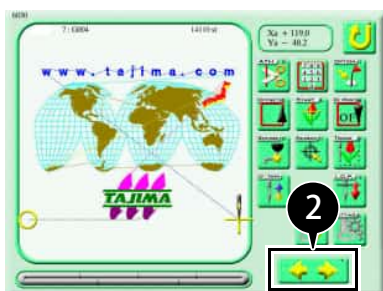

2 Press .

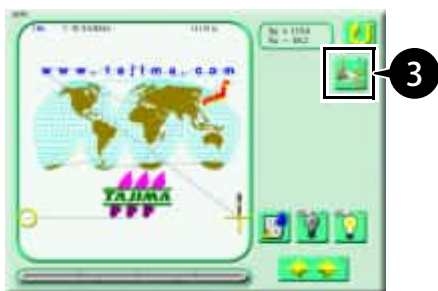

3 Press .

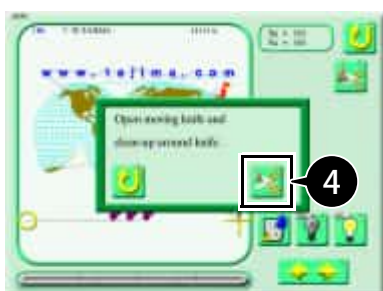

4 Press .  
The trimmer-movable knife opens.

### ■ Cleaning of the interior

Remove the needle plate and clean the inside of the rotary hook base.

#### Warning

 To prevent an accident due to an unexpected startup, be sure to turn off the power before accessing the machine.

---



- The open movable knife automatically closes when you turn ON the power after cleaning.

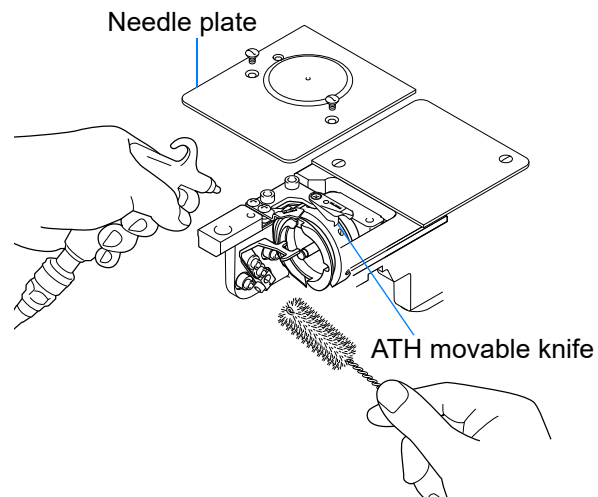

### 3-2. Head and its surroundings

Frequency: Once a week

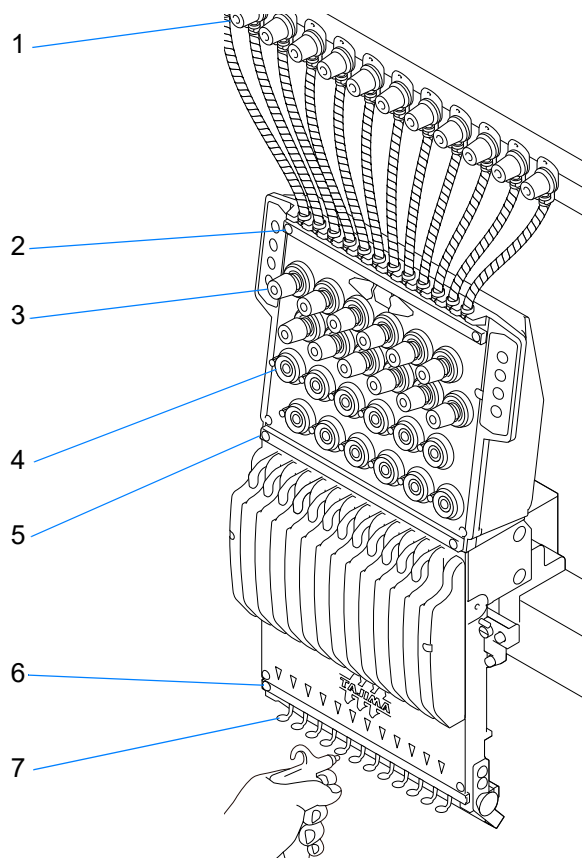

	Cleaning area
1	First thread tension regulator
2	Thread presser (1)
3	Second thread tension regulator
4	Thread break detection device
5	Thread presser (2)
6	Upper thread lock
7	Presser foot

### 3-3. X-axis drive system and Y-axis drive system

Frequency: Once a week

Using an air gun, blow out dust and debris from the slits of each drive system under the table cover.

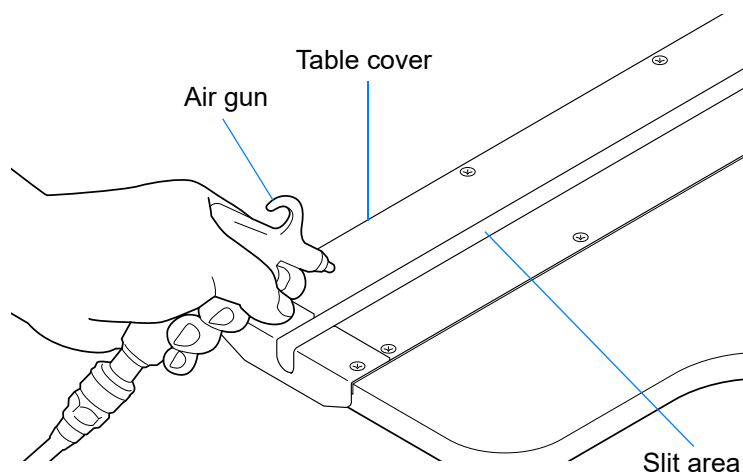

### 3-4. Controller filter

Frequency: Once a week

Remove the filter and vacuum out the dust.

If there is significant dirt, oil, or dust, wash the filter with a mild liquid detergent. After washing, make sure the filter is completely dry before using.

#### **Caution**

 Failure to clean the filter may cause clogging, leading to higher internal temperatures and malfunction.

---



- The filter is a consumable part; replace it regularly with a new one.

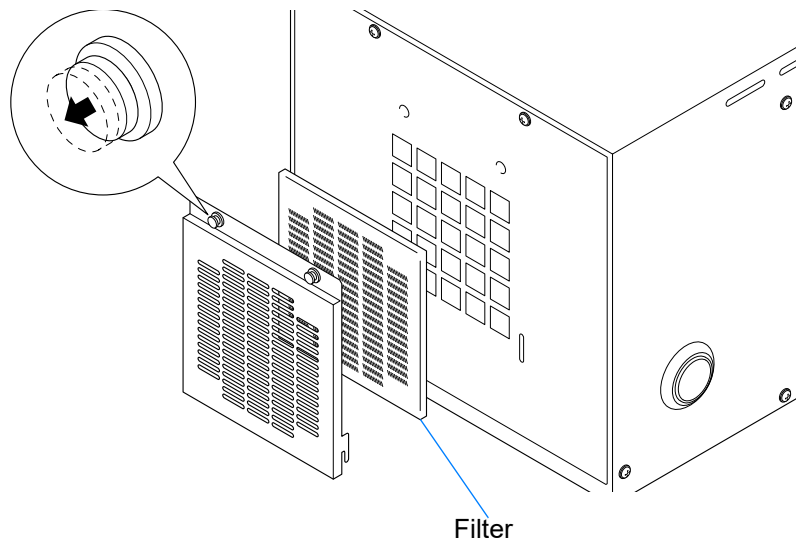

## 4. Lubrication

Perform lubrication using the supplied oiler.

### ⚠ Warning

- ! Maintenance work should be performed by personnel who are trained adequately.
- ! To prevent an accident due to an unexpected startup, be sure to turn off the power before accessing the machine.

### ⚠ Caution

- ! Use only TAJIMA's genuine TF oil or equivalent (Viscosity grade = VG20).
- ! Pour a few drops of oil for lubrication. Using too much oil may cause the oil to drip or scatter, possibly soiling or staining the fabric or thread. Wipe off excess oil with a cloth.

### 4-1. Rotary hook

Frequency: Once every 5 to 6 hours



- To lubricate a lubrication hole, attach the nozzle (accessory) to the tip of the oiler.

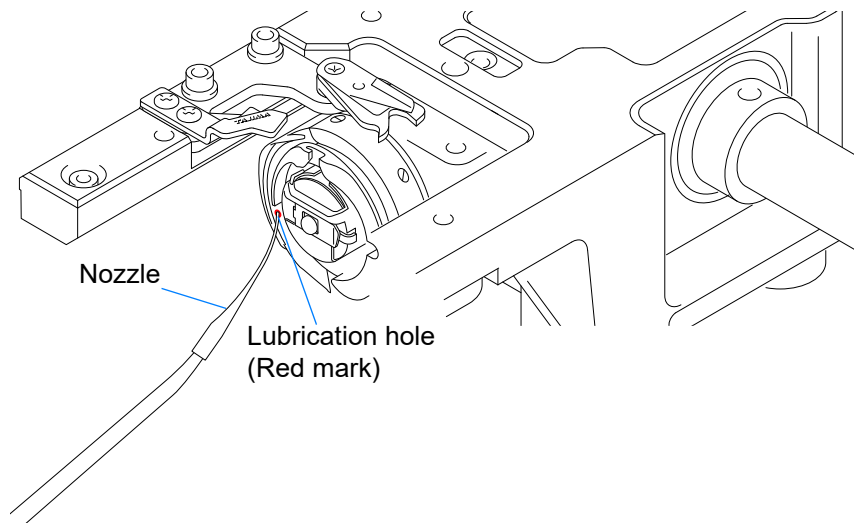

## 4-2. Inside the head

Frequency: Once a week

### Internal lubrication

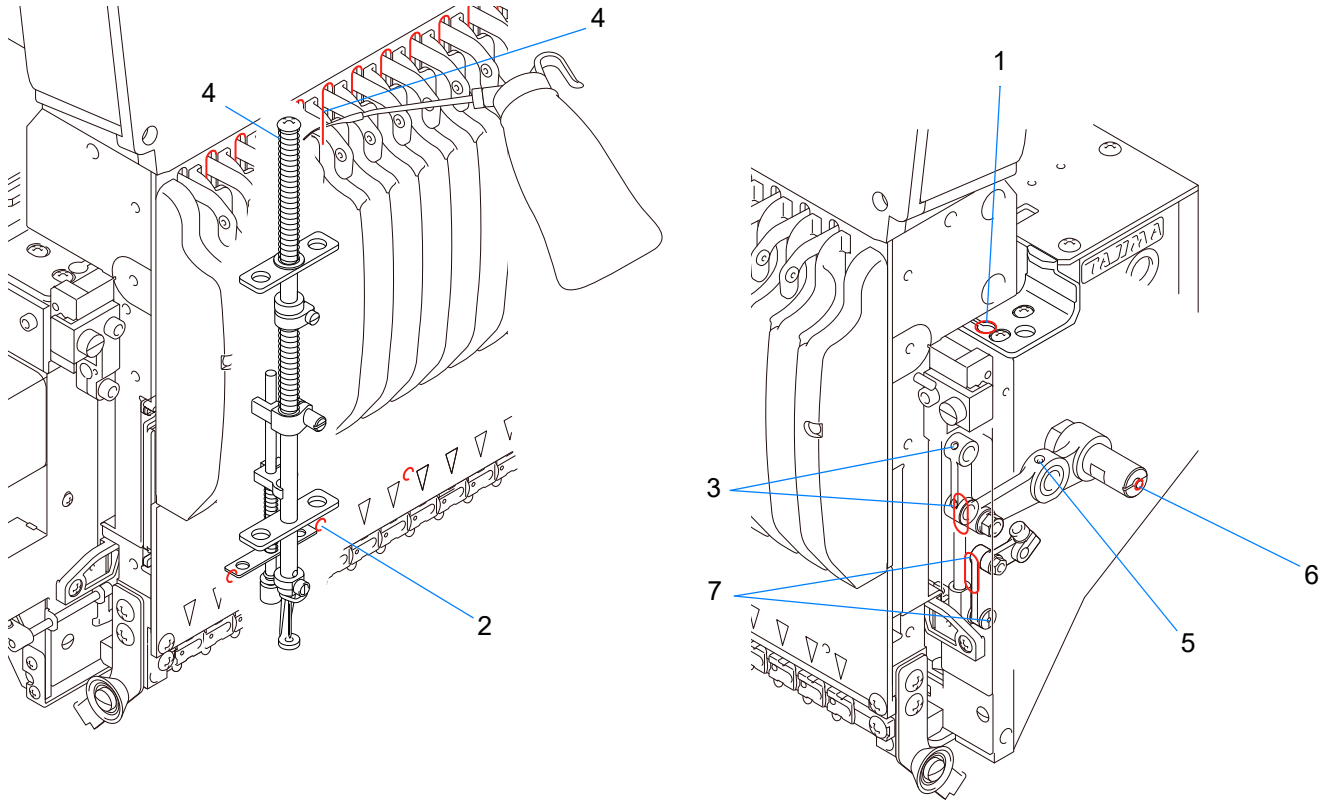

	Lubricating spot
1	Needle bar drive shaft
2	Needle bar (spot indicated by red marks)
3	Lubrication hole of connecting rod
4	Needle bar (all needles)
5	Lubrication hole of needle bar lever
6	Lubrication hole of stepped pin
7	Presser foot drive system

## 5. Greasing

This section contains information intended for use by service personnel authorized and trained by TAJIMA.

### Warning

- ! Greasing must be performed by your distributor or service personnel authorized and trained by TAJIMA.
- ! To prevent an accident due to an unexpected startup, be sure to turn off the power before accessing the machine.

### Caution

- ! Use a grease specified (described below) by TAJIMA or equivalent to maintain proper lubrication inside of the head. Use of grease other than those listed below could cause trouble due to lack of or poor lubrication.

Manufacturer of grease specified by TAJIMA: NIPPON GREASE Co., Ltd.				
Parts to be greased	Part name	Item No.	Base oil	Thickener
Rotary hook base gear	KING STAR EP NO.2: 400G	750103004000	Refined mineral oil (about 75%)	Lithium soap (about 15%)
Inside of head	NIG LUBE PG: 300ML	750104001000	Olefinic synthetic oil	Lithium soap



- For questions regarding greasing and how to obtain grease, consult your distributor.

### 5-1. Rotary hook base gear

Frequency: Once every six months

Grease the rotary hook base gear using the grease specified by TAJIMA.

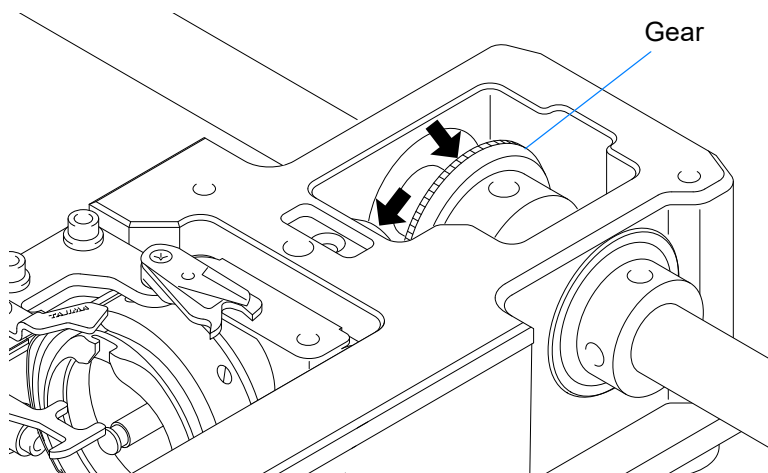

## 5-2. Inside the head

Frequency: Once every three months

Grease up the moving parts of the head, using grease specified by TAJIMA.

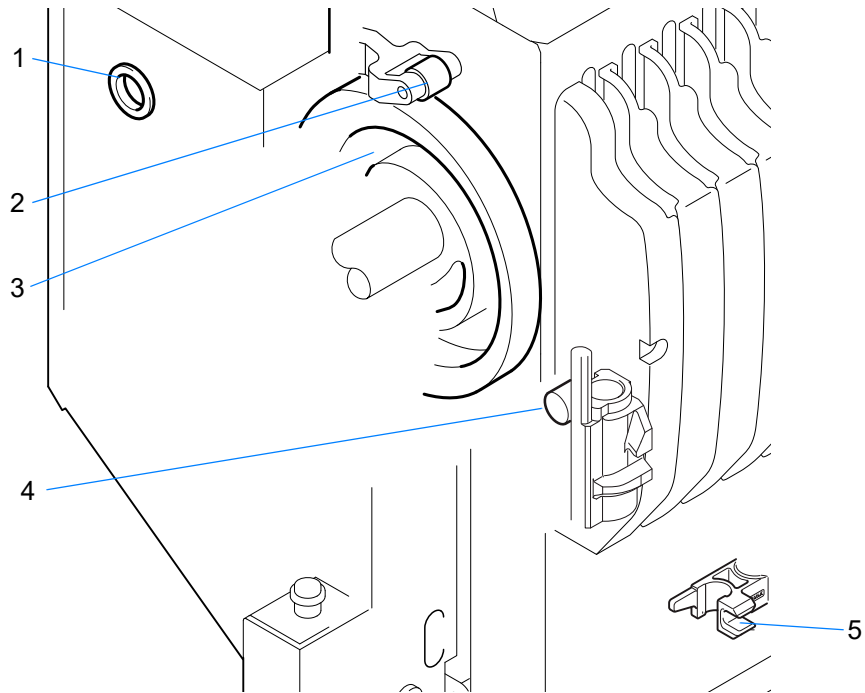

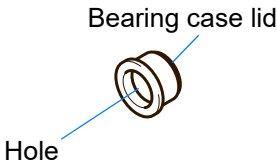
Greasing points	
1	<p>Take-up lever shaft holder</p> <p>Inject grease from the hole in the bearing case lid, using a syringe.</p> 
2	Take-up lever roller
3	Take up lever cam
4	Jump roller
5	Presser foot reciprocator



## 6. Inspection and Repair

This section contains information intended for use by service personnel authorized and trained by TAJIMA.

### 6-1. Inspection of drive systems and sliding parts

Frequency: Once every three months

#### **Warning**

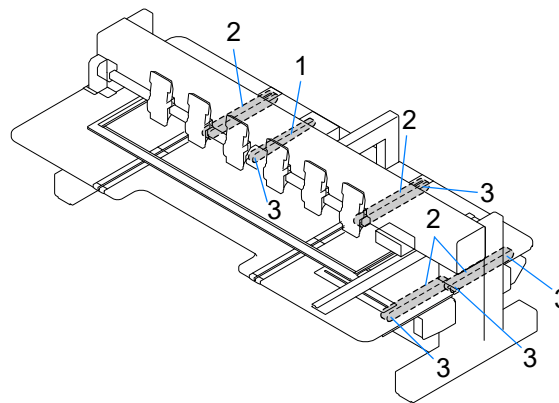

-  Inspection of drive systems must be performed by your distributor or service personnel authorized and trained by TAJIMA.
-  Before work, turn OFF the power and remove the power plug from the outlet. Some circuits hold residual voltage even after you remove the power plug. Wait until they are completely discharged (for at least 4 minutes), and then start your work.



Inspection point		Inspection content
1	Each belt in main shaft drive system	Belt tension, extent of wear, presence of cracking
2	X- and Y-axis drive belts	Belt tension, extent of wear, presence of cracking
3	Rotating, sliding section	Extent of wear of shaft, bearings, etc.

### 6-2. Repair

#### **Warning**

-  Repair of the machine must be performed by your distributor or service personnel authorized and trained by TAJIMA.
-  Do not change the specification nor modify the parts of the machine without due consultation with TAJIMA. Such modification may risk the operational safety.
-  Before work, turn OFF the power and remove the power plug from the outlet. Some circuits hold residual voltage even after you remove the power plug. Wait until they are completely discharged (for at least 4 minutes), and then start your work.

#### **Caution**

-  For the machine repairs, use TAJIMA genuine replacement parts.

# 7. Checking and Adjustment

This chapter describes how to check the height of the needle bar's lower dead point and how to adjust the thread take-up spring stroke amount.

## Warning

! Maintenance work should be performed by personnel who are trained adequately.

## Caution

! Take care to prevent the needle from sticking you in the finger.



### 7-1. Checking the needle bar lower dead point

The machine is adjusted by default so that the needle bar reaches the lower dead point (the lowest point) when the main shaft angle is at 178°. If you often encounter problems such as frequent thread or needle breakage or poor stitch quality, the needle bar lower dead point may be incorrect. Check the status using the supplied lower dead point gauge.

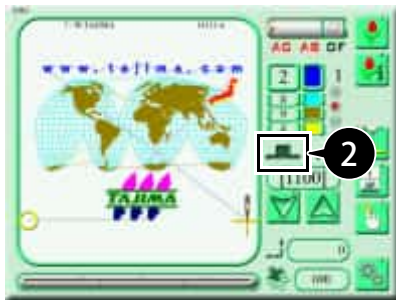
The following example shows how to check the first needle bar.



1 Make sure the machine is on needle number 1 using the operation panel.

2 Hold down  for more than two seconds.  will blink, and the main shaft brake will be released.

When you hold down  again, the main shaft brake will be re-engaged.

3 Press  on the tension base twice to lower the presser foot to the lower dead point.

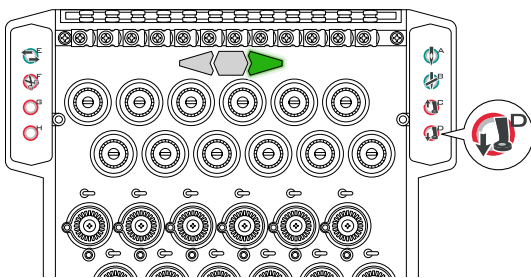

4 Insert the main shaft handle into the machine left side box.

5 Turn main shaft handle 1 counterclockwise to set the main shaft angle to 178° (needle bar lower dead point).

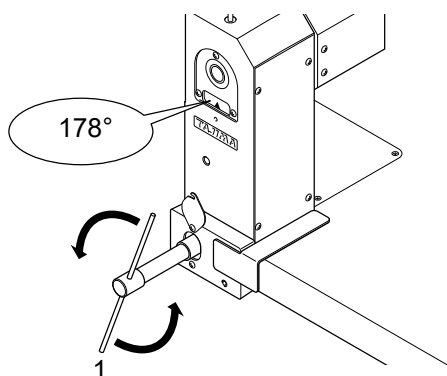

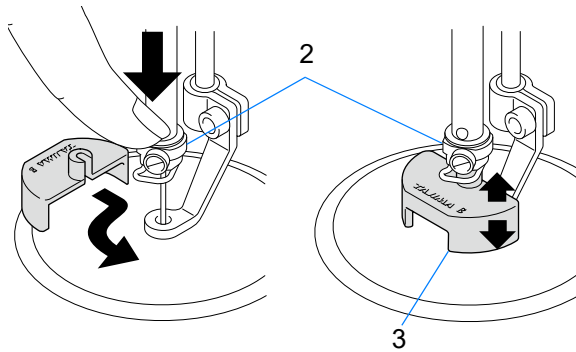

6 Manually lower needle clamp 2 and lower the needle bar.

7 Insert lower dead point gauge 3 into the needle clamp.



- Use the lower dead point gauge with a "B" mark. Gauges without a "B" mark are for other models and cannot be used.

8 Ensure that lower dead point gauge 3 has no play.



- If there is play in the lower dead point gauge, refer to the "Setup Manual" for adjustment.

9 Remove lower dead point gauge 3.

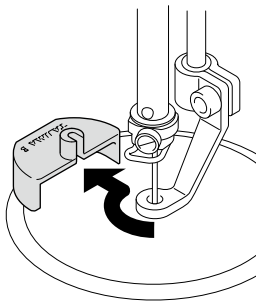

10 Turn main shaft handle 1 clockwise to set the main shaft angle to 100° (stop position).

11 Remove main shaft handle 1.

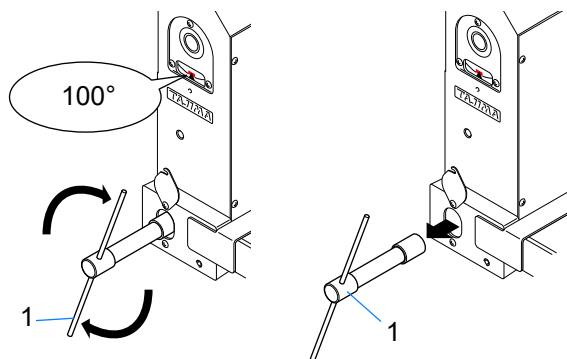

12 Press  on the tension base to retract the presser foot.

13 Hold down  .  
The main shaft brake is engaged.

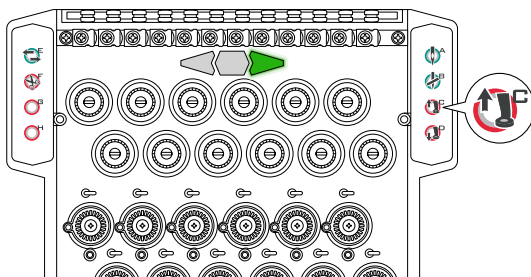

## 7-2. Adjusting the thread take-up spring stroke amount

When you want to strengthen or weaken the thread tightening, adjust the stroke amount of the thread take-up spring inside the middle thread guide.

### ■ Removing the middle thread guide

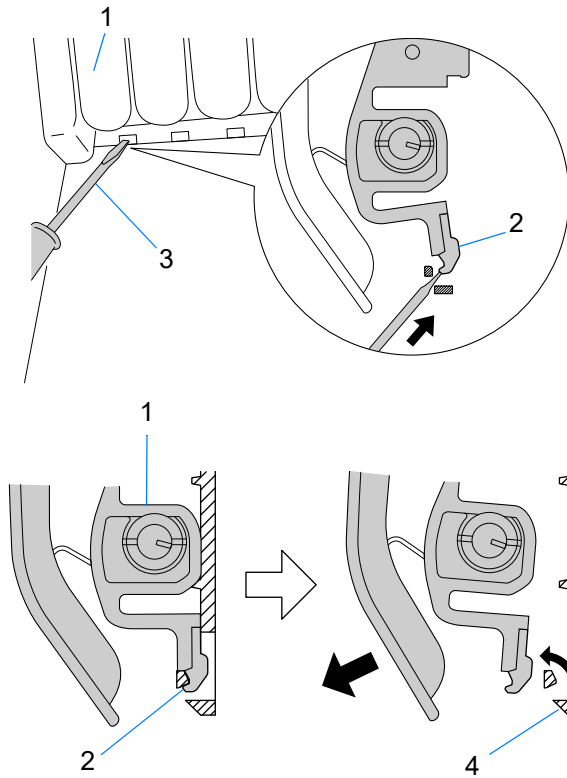

- 1 Remove middle thread guide, 1 from the top cover, 4 by pushing the pawl, 2 with something that has a sharp tip, 3 and pull it towards you.

## ■ Stroke amount adjustment

Adjust the thread take-up spring stroke amount by turning the spring shaft using a coin or the like inserted into its groove.

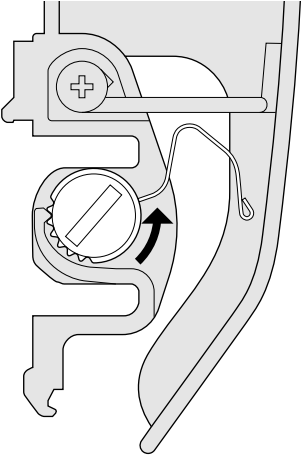
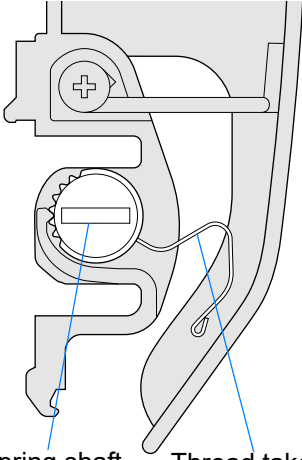
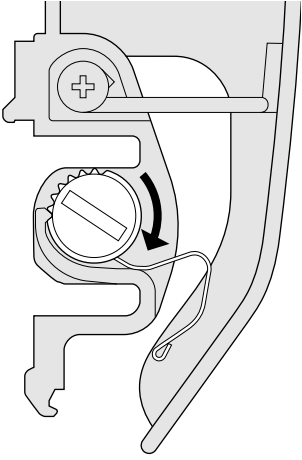
Thread tightening	Getting weaker	Standard	Getting stronger
Stroke	Minimum	Standard	Maximum
Maximum adjustment	Three notches in the counterclockwise direction	Position by factory default	Two notches in the clockwise direction
Condition			

## ■ Installing the middle thread guide

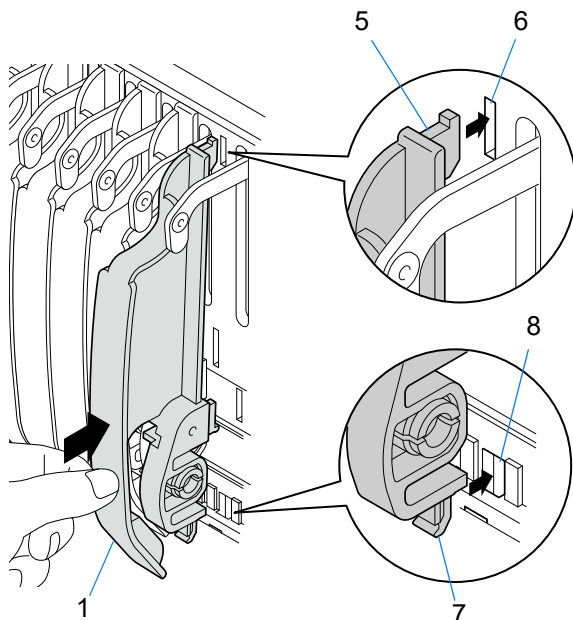

- 1 Insert the upper pawl, 5 of the middle thread guide, 1 into slit, 6 and fit locking pawl, 7 into hole, 8 by pushing it up with your finger.
- 2 Push the middle thread guide, 1 until it clicks into place.

# 8. Others

This section contains information intended for use by service personnel authorized and trained by TAJIMA. After you remove the tension base cover for such purposes as replacing a card, fasten the harness with the coated clip and pull it out so that the tube marker is outside of the grommet.

## ⚠ Caution

! Failure to observe this precaution may cause the harness to get caught on the card, possibly destroying the card and/or harness.

### 8-1. Precautions to take when installing the tension base cover

[Fasten with the coated clip]

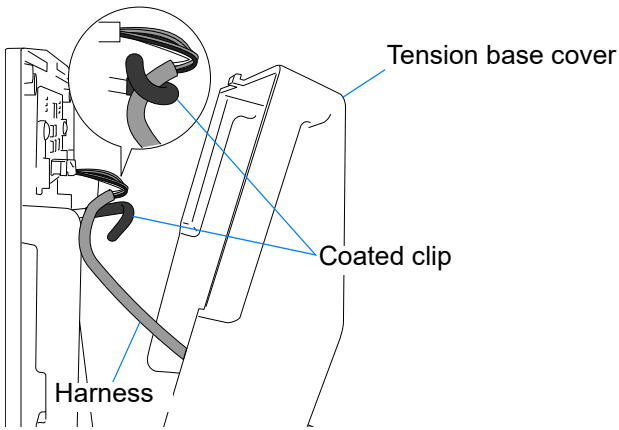

[Pull out the tube marker]

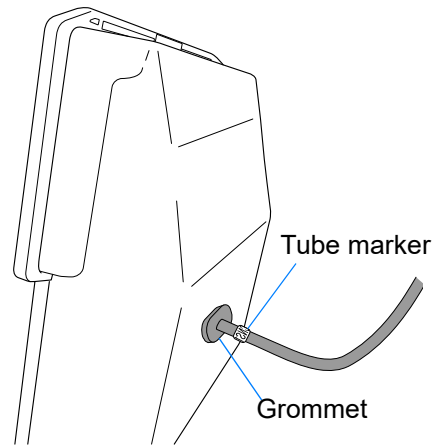

# Chapter 9

## Troubleshooting

### 1. Message Screen

When the machine stops during operation, a message screen appears on the operation panel. Perform troubleshooting based on the code No. and message displayed on the message screen.



#### Warning

 Code numbers affixed with \* in the following table must be corrected by your distributor or service personnel authorized and trained by TAJIMA. Failure to observe this may result in injury, electric shock, or other serious accidents.

Code	Stop factor	Corrective action
1B1	Stop by frame stepping code Not caused by a malfunction.	Perform "Start", "Frame Back/Forward", or press any operation key to continue machine operation.
1B2	Stop by color change code Not caused by a malfunction.	
1B3	Stop by end code Not caused by a malfunction.	
1B4	Stop by thread trimming code Not caused by a malfunction.	
1B5	Stop by sequin code Not caused by a malfunction.	Perform "Start", "Frame Back/Forward", or press any operation key to continue machine operation.
1B6	Stop by automatic arbitrary offset code Not caused by a malfunction.	
1B8	Stop by pause code Not caused by a malfunction.	
1C1	Stop by the stop button Machine stopped by operator.	Continue the operation of the machine if needed. Turning OFF the main power with the code 1C1 displayed on the message screen may render it impossible to continue embroidery.
1C2	Stop by manual ATH	Continue the operation of the machine if needed.

1. Message Screen

Code	Stop factor	Corrective action
1C3	Halt by input of external stop signal Machine stopped by the stop signal from an external device.	Continue the operation of the machine if needed.
1C4	Stop by tension base switch. The machine stopped by changing the tension base switch from clutch to normal during ESQ-C operation.	Perform "Start" to continue machine operation as necessary.
1D1	Halt at Frame Back start point Machine stopped by the halt setting at the start point of embroidery for all heads after Frame Back operation.	Perform "Start" to continue embroidery.
1D2	Preset Halt Machine stopped by the preset halt setting.	Reset the machine by pressing the reset button. Perform "Start" to continue embroidery.
1D3	Stop for material processing Machine stopped by automatic stop setting for material processing.	Cut or trim the material as needed or otherwise process the material. Continue machine operation if needed.
211-01	Fixed position signal error Machine stopped at other than the fixed position.	Return the main shaft to the fixed position. Adjust the encoder/encoder Z signal.
212	The needle bar is out of position The needle bar has been lowered.	Raise the needle bar and operate the machine.
213	Lower dead point error Machine is stopping at the lower dead point.	Raise the needle bar and operate the machine.
*214	Main shaft position signal error Main shaft position information is not changing.	Check and replace the high-speed communications harness connecting the CPU, IDU, and Head cards.
221	+X axis limit signal detection The embroidery frame moved to the limit (left). (+X direction)	Move the frame manually to embroider within the embroidery space.
222	-X axis limit signal detection The embroidery frame moved to the limit (right). (-X direction)	Move the frame manually to embroider within the embroidery space.
223	+Y axis limit signal detection The embroidery frame moved to the limit (front). (+Y direction)	Move the frame manually to embroider within the embroidery space.
224	-Y axis limit signal detection The embroidery frame moved to the limit (rear). (-Y direction)	Move the frame manually to embroider within the embroidery space.
251	Oil level error The lubricating device's oil level is abnormal.	Add oil to the oil tank.
*258	Upper dead point sensor error Upper dead point sensor error detected.	Check/replace the upper dead point sensor of the ESQ-C.
*259	Lower dead point sensor error Lower dead point sensor error detected.	Check/replace the lower dead point sensor of the ESQ-C.
*25A	Sequin color change sensor failure Color change sensor error detected.	Check/replace the color change sensor of the ESQ-C.

Code	Stop factor	Corrective action
25C	Cord cutting device error The cord cutting device encountered a positioning error or did not complete initial operation.	Turn OFF/ON the main power. Check/adjust the cord cutting device.
274	Presser foot error The target position is not detected, even if 3 seconds have passed since the presser foot movement.	Check/adjust the presser foot.
281	Color changing error The target needle position is not detected even if 8 seconds have passed since the start of color change.	Correct the needle position. Adjust or replace the potentiometer.
291	Upper thread breakage Machine detected upper thread breakage.	Check the upper and under threads. Check or replace the tension base card.
293	Under thread breakage Machine detected under thread breakage.	Check the under thread. Check or replace the tension base card.
294	Material runout detected Machine detected that sequin material has run out.	Check/replace Sequin material.
*2A1	Thread trimming position adjustment error Adjustment time of thread trimming position was exceeded.	Return the ATH movable knife to the fixed position. Check or replace the thread trimming motor or the thread trimming motor encoder.
2A3	ATH thread separation error	Check the upper and under threads and perform "Start" to continue embroidery.
2A4	ATH Skip stitch error	
2B3	End code contains data Data is found in end code.	Delete "X/Y travel amount of the end code" from the design data.
2B4	Function code error Function code error occurred.	There is a function code that is not defined. Correct the design data.
2B7	Data set incomplete Data set is not completed.	Operate the machine after setting the data for an embroidery design.
2B8	Data pre-reading buffer error Output data cannot be prepared.	During operation: decrease the machine RPM. During Frame Forward: do not perform Frame Forward any more.
*2B9	Memory write error Cannot write data into memory.	Check and replace CPU card/operation panel.
2BA	Memory capacity exceeded Remaining memory space is insufficient.	Increase the free space of the memory by deleting unnecessary designs registered in the memory (after taking the backup if needed).
2BB	Frame Back limit over Frame Back exceeded available range.	Do not perform Frame Back any further.
2BC	Design No. error Design No. is not found. Cannot edit the design because the data is currently set. The design is not registered in memory.	Set the data for the same or other design and then edit the desired design. Register designs in the memory.
2BE	Incorrect function code segment Start/end codes are not registered in a pair for the function which has start/end.	Modify/set the design again so that the codes of start/end become a pair.

1. Message Screen

Code	Stop factor	Corrective action
*2BF	Memory read error Memory cannot be read.	Check/replace the operation panel.
2C1	Insufficient program setting	Operate after exiting the parameter setting screen, the other setting screens, the manual operation screen.
2C6	Operation of the machine was performed during bobbin changer operation.	Do not operate the machine during bobbin changer operation.
2C7	Password requested Password is required. The password you entered is not valid.	Input the correct password.
2CE	Stop by safety device Machine was stopped by a safety device stop signal.	After confirming safety, continue machine operation if needed.
2E2	Air pressure error Air pressure has become lower than the required level.	Check/adjust the supplied air pressure.
2E3	Power failure during operation The power supply was cut/shut off during main shaft operation.	Turn ON the main power and perform power resume.
2F1	i-lever position error An i-lever position error was detected	Turn OFF/ON the main power. Check/replace the head BB card.
*311-01	Encoder A signal error	Check the encoder signal lines. Check the main shaft driver for excitation.
*312-01	Encoder Z signal error	Check the encoder signal lines.
*314	Main shaft revolution error	Make sure the rotary hook and the main shaft are not jammed. Remove whatever has them jammed.
*316-01	Main shaft motor error	Turn OFF/ON the main power. Check or replace the main shaft motor/IDU amp.
*321-01	Frame driver irregular signal	Decrease the machine speed. Check/replace the IDU amp/frame motor.
*331	Abnormal bobbin changer signal detected.	Operate the bobbin changer manually after resetting the error, and check/adjust the section that caused the error.
*361-04	Jump Driver signal error	Turn OFF/ON the main power. Decrease the machine speed. Check or replace Head card A.
376	Presser foot position error	Turn OFF/ON the main power. Decrease the machine speed. Check/replace the Head card B or BB.
*382-01	Time elapsed to move to selected position	Check/replace the color change motor/encoder and potentiometer (needle position sensor).
*383-01	Needle position error	Move the needle bar position into the setting range. Check or replace the potentiometer (needle position sensor) or the color change encoder.
*384	One-turn signal is not detected	Check/replace the photo interrupter (1-rotation sensor) and color change encoder.
*3A1-01	Thread trimming driver error detected	Turn OFF/ON the main power. Check/replace the thread trimming motor/joint 31 card.

Code	Stop factor	Corrective action
*3A6	ATH Movable Knife Open	Check the position of ATH movable knife.
*3B6	Communication error	Check/replace the high-speed communications harness connecting the CPU and Head cards.
3BE-**	Network communication error	Check the network connection settings. Turn OFF/ON the machine and the connected devices such as DG/ML. Check the connection cable.
*3C1	Start/Stop switch error	Check or replace the connector/connection terminal/limit switch. Turn OFF/ON the main power.
*3C2-01	Frame travel key error	Check or replace the frame travel switch. Turn OFF/ON the main power.
*3D1	Battery signal error	Charge/replace the battery. (operation panel)
*3D2	Battery signal error	Charge/replace the CPU card's battery.
*3D9	Fan Motor error	Replace the power supply box's fan motor.
*3DA	Permanent Counter error	Check/replace the connection of the permanent counter.
3F4	Tension control overload error i-TM driver error	Turn OFF/ON the main power. Check/replace the Head card BB.
5C3	Color change sequin setting error	Check/change the sequin device parameter setting on the operation panel.
5C6	General external device is operating.	Do not operate the machine during the operation of general external devices.
*6B5-**	Communication error	Turn OFF/ON the main power. Install the system software. Check or replace the related cards.
*6D4	Shunt connection error	Connect the harness for Shunt.
OIL	Preset Halt Machine stopped by the preset halt (Lubrication) setting.	After lubricating the necessary spots, reset the machine by pressing the reset button. Perform "Start" to continue embroidery.
B01	Formatting error The memory media is formatted incorrectly. Cannot read or write data.	After making a backup, format the memory media. Use new memory media.
B03	Write protect error The memory media is write-protected.	After canceling the write-protection for the memory media, perform the writing.
B04	Empty media error Memory media is not inserted.	Insert memory media.
BC1	Unregistered design No. Design No. is not found.	Perform design selection again.

## 1. Message Screen

---

<b>Code</b>	<b>Stop factor</b>	<b>Corrective action</b>
BC3	Disk file error This memory media cannot be read.	After making a backup, format the memory media. Use new memory media.
BC4	Verify error Abnormal Stitch Data found on Media.	Perform writing again.
BC5	Memory capacity insufficient error	Replace the memory media with one that has enough remaining capacity. Then press the reset button to continue the operation.

## 2. When the Machine Does not Stitch Well

If the machine does not stitch well, investigate the cause with reference to the following.

If the cause is unknown or the problem recurs, consult your distributor.

### 2-1. Frequent thread breakage

Cause	Troubleshooting
Improper thread tension	Adjust the tension. Upper thread = 120 to 140 g, under thread = 20 to 30 g
Poor thread flow	Use silicone.
Direction of needle is bad or needle is bent.	Adjust to face to the front or to the right a bit. Replace the needle.
Applique glue is built up on the needle.	Remove the glue.
Lint/dust build up, rotary hook is dry	Clean and lubricate.
Numerous tiny stitches of 0.5 mm or less in the design	Remove tiny stitch(es).
The fabric is floating too much from the needle plate or is touching too hard.	Replace the clips. Stretch the fabric again so that it lightly touches or is slightly above the needle plate.
Needle bar is dried out.	Add lubrication.
There is a scratch on the thread course and /or rotary hook.	Remove the scratch with extra fine sandpaper etc. Replace the rotary hook or the thread course.
Bad presser foot height	Adjust it so that the height is appropriate for the fabric/material.
The combination of frame drive timing and embroidery condition is inappropriate.	Change the setting.

### 2-2. Needle breaks

Cause	Troubleshooting
Improper thread tension	Adjust the tension. Upper thread = 120 to 140 g, under thread = 20 to 30 g
Density of design data is very high	Correct the design data. Delete unnecessary underlay stitching.
The material is too thick or hard.	Use material suitable for embroidery.
Bobbin is deformed and the needle touches it.	Replace the bobbin.
Needle deterioration, mis-matched for embroidery condition	Replace the needle. Use an appropriate needle that fits the conditions.
Vibration of the machine is excessive.	Center support is too loose. Tighten the support by hand. Adjust leveling.
The combination of frame drive timing and embroidery condition is inappropriate.	Change the setting.

### 2-3. Poor embroidery results

Cause	Troubleshooting
Improper thread tension	Adjust the tension. Upper thread = 120 to 140 g, under thread = 20 to 30 g
Poor thread flow	Use silicone.
Density of design data does not match with material and/or thread.	Correct the design data.
Poorly attached frame and loose fabric/backing	Attach the frame correctly. Re-hoop the fabric/backing properly.
The combination of thread, needle and/or the size of needle plate are inappropriate for the embroidery conditions.	Use the appropriate combination that fits the design/material.
R.P.M. is too high.	Decrease the R.P.M.
The combination of frame drive timing and embroidery condition is inappropriate.	Change the setting.

## 3. Power Resume after Power Failure

If the power is interrupted due to a power failure or the emergency stop switch during embroidery, turn ON the power and perform power resume.

### ⚠ Caution

- ⊘ Do not put your hands on the table when you operate the machine. Doing so may cause your finger or hand to be injured when the needle bar or frame moves.



- 1 Press  on the message screen.  
The power resume selection screen appears.

- 2 Select the power resume method.



: Perform power resume after trimming the thread.



: Perform power resume without trimming the thread.



- When you perform power resume, the machine resets the absolute origin and the frame moves to a position several stitches prior to the position where the power was interrupted.

1

2

3

4

5

6

7

8

9

10

# 4. Obtaining Backup Data

The machine operation history and communication history are recorded as backup data in the machine. If the distributor requests you to provide backup data for the purpose of investigating the cause of a problem, save the backup data in a USB memory using the following procedure.

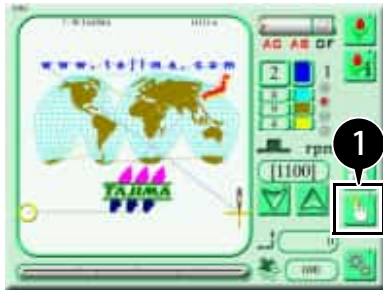

1 Insert the USB memory into the USB port of the operation panel and then press  on the main screen.

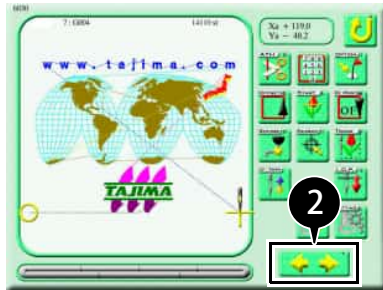

2 Press .



3 Press .

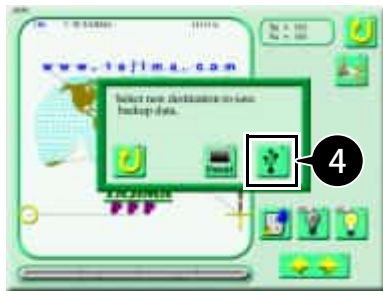

4 Press .

The backup data saved on the CFast card in the operation panel and the backup data you have obtained will be saved on the USB memory.



- Pressing  saves the backup data on the CFast card in the operation panel up to 50 times. After exceeding 50 times, the existing backup data will be overwritten.

5 Remove the USB memory from the USB port.

# Chapter 10

## Appendix

### 1. Improving Embroidery Quality (FS Mode)

FS mode improves the embroidery finish even if you use roughly finished (tinsel, thick thread) or loosely twisted thread.

This function is especially effective for embroidery using loosely twisted thread that was previously considered inappropriate for embroidery machines.



- You can configure FS mode using a parameter. For details, refer to the separate "Parameter Settings" manual.

#### 1-1. Function outline

##### ■ Improvements by FS mode

- Decreasing thread breakage (Tinsel)
- Improvement of thread tightening for satin stitches (Loosely twisted thread, thick thread)
- Stabilization of satin stitches (Loosely twisted thread)
- The balance between upper and the under threads is stable on the back side of the fabric. (All thread types)
- Decrease of loosely tightened stitches for emblem embroidery (Polyester yarn)



- The above information is not applicable to all embroidery conditions. No improvement may be gained for certain embroidery conditions.

##### ■ Movement of the machine in FS mode

FS mode is a function that gives priority to embroidery quality. Therefore, productivity will be lower under the following conditions.

Please use it keeping the following in mind.

- Maximum RPM will be limited.

## 1-2. Stitch comparison

### ■ Stitch comparison showing the difference between standard and FS mode

Thread type: Rayon 300 d/1

FS mode



Standard



### ■ Sewing comparison between different threads

The following sewing samples (A, B, and C) were embroidered in FS mode. Even if you use a loosely twisted thread, you can perform embroidery as shown in samples A and B.



- If samples A and B (especially A) are embroidered in standard mode, problems such as fluffing and looping will occur.

Loosely twisted thread  
(Rayon 300 d/1)



Thread twisted a little looser  
(Middle level of twist between A  
and C)  
(Polyester 120 d/2)



Normal embroidery thread  
(Rayon 120 d/2)



## 1-3. Making use of optional parts

We can provide optional parts to improve the embroidery quality.

Consult your TAJIMA distributor to arrange optional parts that best suit the threads and embroidery fabric you plan to use.

### ■ Examples of using optional parts

Embroidery conditions	Optional parts
In case of using tinsel	Thread guide, snarl prevention
In case of using thick thread	Dedicated needle plates
In case of using loosely twisted thread	Thread guide, dedicated needles

\* Optional parts may not be applicable to your conditions, depending on the threads, designs, and fabrics you use.



- Thread guides, dedicated needles and needle plates are not sold as "set" items.
- Sample items, thread guides and needles for 2 needle bars come with your machine.

### ■ Thread guide

In case of using roughly finished thread, the upper thread tension will be too tight. Therefore, detach the spiral tube, and attach this thread guide.

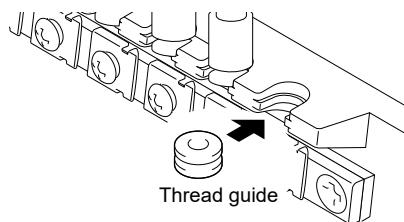

Part name	Part No.
Thread guide: 2.2 MM DIA.	516501040000



- When a large interval change is performed, thread tangles may occur.

### ■ Dedicated needle plates

The hole diameter has been increased to accommodate thick thread.

Part name	Part No.
Needle plate: 2.5 MM DIA.	050340551010

1

2

3

4

5

6

7

8

9

10

### Dedicated needles

Needles developed especially for FS mode. They are effective for loosely twisted threads that would otherwise be conventionally difficult to embroider.

Part name	Part No.
Needle: DB-K5Z1 FS #11 U	616500570000
Needle: DB-K5Z1 FS #11 Y	616500580000
Needle: DB-K5Z1 FS #14 U	616500590000
Needle: DB-K5Z1 FS #14 Y	616500600000



- Not suitable for fabric that requires increased force for the needle to penetrate through.

### Snarl prevention

This feature prevents snarl (tangling of thread) when unwinding thread from bobbins.

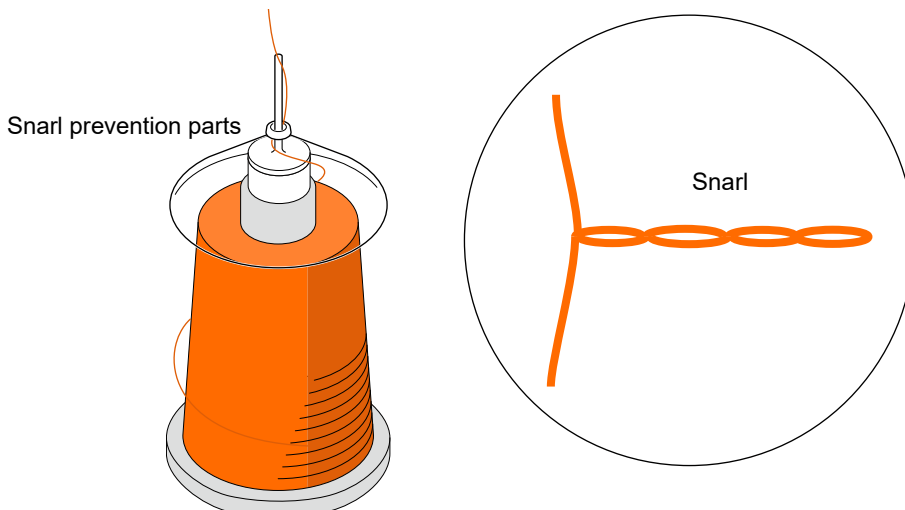

Part name	Part No.
Snarl prevention parts	911400100T00

## 2. Upgrading the Software Version

The latest software is installed in this machine at the time of production. When it is necessary to upgrade the software at a later time, install the latest version of software.

Regarding the contents and how to obtain the latest version of software, please consult your distributor.



- This operation requires input of your password. After you enter the password, you cannot perform the following operations until you turn off and back on the power. For details, consult your distributor.

### Explanation on the screen

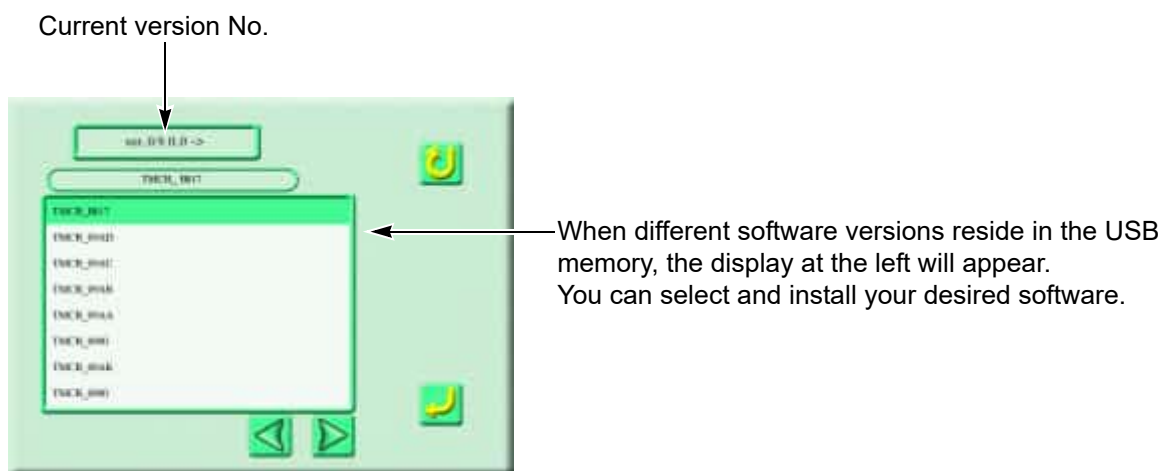

### How to operate

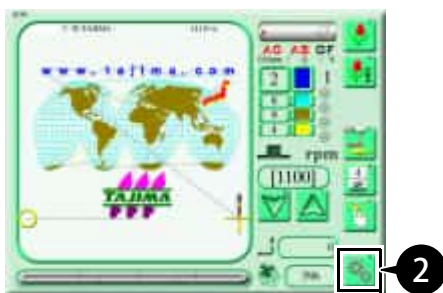

1 Insert a USB memory containing software into the USB port on the operation panel.

2 Press  on the main screen.



3 Press  twice.

1

2

3

4

5

6

7

8

9

10



4 Press  .



5 Input your password.

6 Press  .

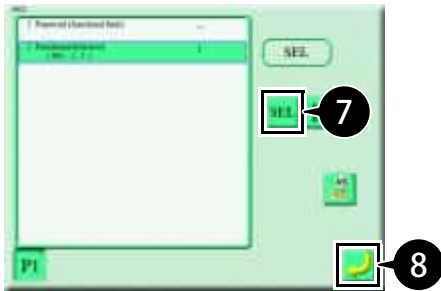

7 Press  .

8 Press  .



9 Press  .



10 Select "85. Machine adjustment".

11 Press  .

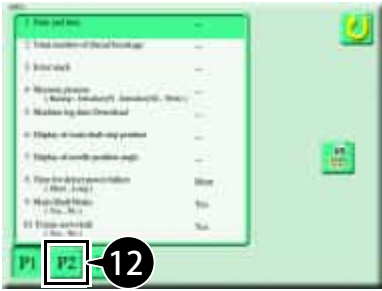

12 Press  .

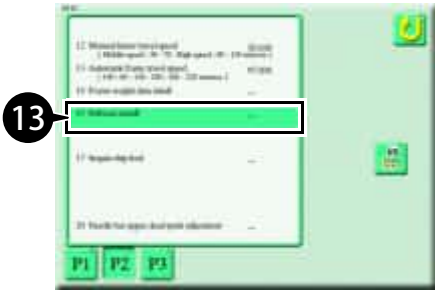

13 Select "15. Software install".



• If the software installation is not displayed, refer to "Display/hide each parameter item" in the separate "Parameter Setting" manual.



14 Press  .



15 Press  .

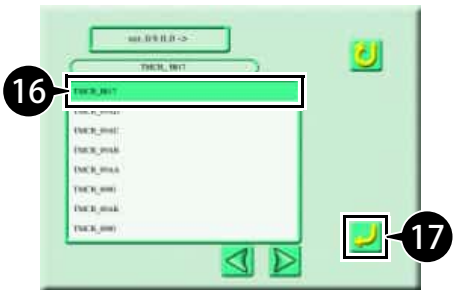

16 Select your desired software.

17 Press  .

1  
2  
3  
4  
5  
6  
7  
8  
9  
10



18 Select the installation method.

**Default** : Only install the necessary systems

**ALL Yes** : Install all of the systems



• To overwrite the same software, select



19 Press .

The software is installed.

20 When the completion screen appears, remove the USB memory from the USB port on the operation panel.

21 Turn ON the power again.



**⚠ Caution**



To turn ON the power again, wait for 30 seconds or more. Otherwise the system will fail to start up normally.

## 3. Specifications

### 3-1. Electrical specifications

Allowable voltage range	Within $\pm 10\%$ of the rated voltage
Frequency	50/60 Hz
Apparent power	2.1 kVA
Active power	1.2 kW
Insulated resistance	10 M ohms or greater (500 megger insulation tester)

### 3-2. Ambient noise level

The ambient noise level of the machine is less than 85 dB. Measuring conditions are as follows.

Measuring ambience	Refer to the illustration on the right.
Measuring position	Measured at position A at a height of 1.6 m from the floor and a distance of 1.5 m from the needle bar case.
Working machine condition	Fabric is stretched on the border frame, and embroidered a design which has 4 mm width.
R.P.M.	Maximum number of revolutions of machine
Measuring instrument	Compliant to IEC61672-1: 2002 Class 1

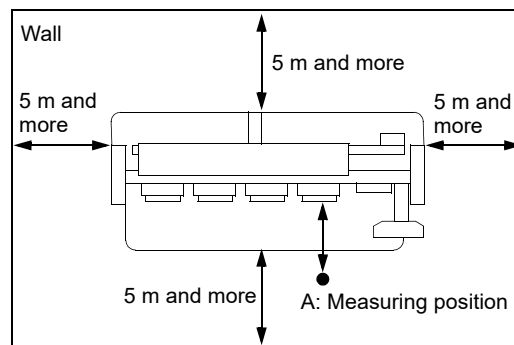

### 3-3. Machine weight

Machine weight is described on the Specification Plate.

## 4. Terminology

The following terms are common to all the models. They may not apply to some models.

### <A>

#### Absolute origin

An anchoring point to calculate the current frame position (Xa + 0.0, Ya + 0.0).

#### ATH

The abbreviation of Automatic Thread Trimming and Holding Device.

#### Auto Jump

To make a stitch divided into two stitches as less than setting value automatically when its stitch length exceeds the setting value. It is effective to prevent the slippage of the frame and the displacement of the design.

### <B>

#### Backlash

A play (gap) generated at the drive system and/or around the frame by shock when a stitch returns (when frame drive is reversed). It may affect embroidery finish.

### <C>

#### Cleanup

To remove tiny stitches included in design data to make before and after stitches absorb it. It has an effect on decreasing thread breakages.

#### Condition data (CT0)

Embroidery condition included in the design (needle bar selection, data conversion, repeat, start position, automatic offset).

#### CT0

File including the information of needle bar selection and start position. It is necessary to handle TBF, CT0, and DGF as a set on a personal computer.

### <D>

#### Data mode

Saving format of design (T, T2, T3).

#### Data set

To set the design data in the memory of the machine to start the machine.

#### D-axis

Driving shaft to rotate sewing needle and N-Pipe (TCMX series).

#### DG by Pulse

Embroidery design creation software developed by Pulse Microsystems Ltd. It provides the ability to quickly convert vector data to stitches. It also provides the ability to send designs to the machine by connecting DG by Pulse to the machine via LAN.

#### DGF

File that indicates design image. It is necessary to handle TBF, CT0, and DGF as a set on a personal computer.

#### Driver

Control card to make the frame or main shaft drive. X-axis driver, Y-axis driver, main shaft driver, etc. are included.

#### DST

Stitch data for Tajima ternary format. Data saving format is T.

### <E>

#### Excitation

To keep frame motor drive. It is not possible to move the frame by hand during excitation.

**<F>****Fine stitch**

Fine stitch as a factor causing thread breakage.  
Stitch of which the stitch length is 0.5 mm or less.

**Fixed pitch movement**

Horizontal frame travel to the neighboring head by head interval.

**Fixed position**

Angle of the main shaft at which the main shaft motor stops (stop position).

**Frame Back**

To move the embroidery frame only to the direction where the stitches return with the needle bar(s) stopped.

**Frame coordinates**

Frame position in embroidery space. It is indicated like "X: -153.2, Y: +120.4".

**Frame Forward**

To move the embroidery frame only to the direction where the stitches advance with the needle bar(s) stopped.

**Frame Limit**

Limit position that the frame can move (it is indicated by mark-off line on the table).

**Frame stepping**

To move the embroidery frame only with the main shaft of the machine is stopped during embroidery.

**Function Code**

Command code that controls general movements of the machine. All design data consists of function codes (Stitch, Jump, Color, etc.).

**<H>****Head group**

Function that assumes multiple heads as one head by grouping them. This enables large design embroidery or multi-color embroidery with more colors than the number of needles per head.

**<I>****Inching**

Movement to stabilize start of sewing by moving needle bar slowly before the main shaft enters normal operation. It is also executed before thread trimming to stabilize thread trimming.

**<J>****Jump**

To make only the frame move in the state that needle bar does not move down during operation. It is possible to make a longer stitch than one stitch of the maximum length.

**<M>****Main shaft brake**

To hold the main shaft with the brake of the main shaft motor so that the main shaft does not rotate when it stops.

**M-axis**

Drive shaft to rotate N-Pipe and bobbin (TLMX series).

**<O>****Offset start position (Offset position)**

Frame travel start position that is configured by operating the Automatic Offset. The position to make the frame stand by to facilitate changing of frame and/or fabric by moving the frame to the front automatically in the middle of sewing or at the end of sewing.

1

2

3

4

5

6

7

8

9

10

## <P>

### Parameter

Setting items that decide the working condition of the machine.

### Pseudo-fixed position (stop at the lower dead point)

The machine should be stopped with the needle stuck in the cloth at the end of embroidery. Moving the frame in this condition will enable consecutive embroidery.

## <R>

### Return stitches

Tie stitch to be executed at start of sewing (stitch to prevent mis-stitching at start.).

### Running stitch

Decorative stitch of straight line or curved line only.

## <S>

### Satin Stitch

Repeated zigzag stitches. It is mainly used for hem of applique, logo, mark, flower design, etc.

### Seed beads needle

Needle that embroiders with beads by seed beads device. It indicates the first needle or the last needle.

### Sequin needle

Needle that embroiders with sequins by sequin device. It indicates the first needle or the last needle.

### Sidekick

Name of the network application software manufactured by Pulse Microsystems Ltd. It is possible to input the design data to the machine by wireless LAN as a main function.

### Step

The section divided by a color change code in the design. The first section is called Step 1 and the next section is called Step 2.

## <T>

### Table offset

To move the frame to the rear direction temporarily to facilitate threading. It is mainly effective when the frame is positioned at the table cut section.

### Tatami stitch

Stitches to fill in a certain amount of area. They are mainly used for a big logo, background, underlay etc.

### TBF

Stitch data for Tajima binary format. Data saving format is T2. It can support more function codes than DST. It is necessary to handle TBF, CT0, and DGF as a set on a personal computer.

### TCF

Data that integrates TBF, CT0, and DGF. Integration facilitates handling of designs. Data saving format is T3.

### Tie stitches

Tie stitch to be executed before thread trimming (stitch to prevent fray).

## <X>

### X-axis drive system

Drive system to make the embroidery frame move in the horizontal (X) direction.

### X data

The data that makes the embroidery frame move right/left direction (X direction). It is indicated by moving direction (code: +/-) and the value (mm).

**<Y>****Y-axis drive system**

Drive system to make the embroidery frame move in the vertical (Y) direction.

**Y data**

The data that makes the embroidery frame move front/rear direction (Y direction). It is indicated by moving direction (code: +/-) and the value (mm).

**<Z>****Z-axis**

Drive shaft to change needle height (TCMX series).

1

2

3

4

5

6

7

8

9

10

■ **Manufactured by: TISM Co.,Ltd.**

NO.1800, Ushiyama-cho, Kasugai, Aichi-pref., 486-0901, Japan  
Telephone: 81-568-33-1161

■ **Distributed by: Tajima Industries Ltd.**

NO.1800, Ushiyama-cho, Kasugai, Aichi-pref., 486-0901, Japan  
Telephone: 81-568-37-1130