



USER'S MANUAL

Operation

This manual describes the procedures for operating the machine, performing embroidery, and performing maintenance.

TMAR-KC TYPE-2
TMAR-VC

Foreword

Thank you for purchasing the TAJIMA embroidery machine.

Please read this manual thoroughly, understand the contents, and then use the machine.

This manual may contain discrepancies in detailed specifications when compared with the actual product. If you have any question, please ask the distributor for information.

Purpose of This Document



This manual and other documents contain the following information. Refer to the necessary documents depending on the application and purpose. The user's manual and other documents are stored as PDF files on the supplied DVD.

■ USER'S MANUAL

For Safe Use	This manual contains instructions on using the machine safely. Make sure to read the manual before use.
Basics	This manual describes the basic knowledge and procedures that are common to all the models and required to use the machine. If you are a novice to or unfamiliar with the machine, be sure to read this manual first.
Operation (this document)	This manual describes the procedures for operating the machine, performing embroidery, and performing maintenance.
Parameter Setting	This manual describes various parameters.
Frame Change	This manual describes how to change the frames. This does not come with some models.
Various Documents	Electrical system diagrams and other technical documents.
■ Other manuals	
Quick Guide	This sheet is the Quick reference regarding embroidery methods as well as frequently used functions and their operating procedures. Keep the Quick Guide handy so that you can reference it quickly.
Optional Device	This manual describes how to set up, operate, and maintain various optional devices.

Safety Precautions and Symbols



Items that require your special attention on handling the machine are specified below.

Description	Meaning
 DANGER	Indicates that there is a lot of danger of death or serious injuries ^{*1} .
 WARNING	Indicates that there is a likelihood of death or serious injuries ^{*2} .
 CAUTION	Indicates a potentially hazardous situation that may result in minor or moderate injury ^{*2} or physical damage.



*1 A condition caused by electric shock, injury, fracture of a bone, etc., leading to aftereffects or an injury that necessitates hospitalization or visits to a hospital over a long period.

*2 An injury that does not necessitate hospitalization or visiting a hospital over a long period.

The symbols used throughout this document have the following meanings.

Symbol	Meaning
	Item to be prohibited
	Items that may cause electric shock if not observed
	Items to keep safety

Other Precautions

Description	Meaning
	Items that may affect sewing if not observed.
	Recommended and useful tips.



Disclaimer, etc.

- The external views and specifications of the machine and the contents of this manual are subject to change without notice due to improvement.
- The screen captures and figures contained in this manual may differ depending on the machine specifications, the number of heads or needles, and the presence of optional device.
- TAJIMA bears no responsibility regarding any damage arising from not observing the instructions in the manual or any fault or damage resulting from repair, disassembly, or modification not indicated in the manual.
- You may not copy, reproduce, or transcribe a part or whole of this manual without consent of TAJIMA.

Function Limit

To prevent unnecessary export of design and incorrect parameter settings, functional limit levels are used to restrict the use of particular functions.

The following functions are restricted at each functional limit level.

Functional limit level	Limit contents
	No limit <ul style="list-style-type: none"> • All parameters are displayed • All functions are enabled • Parameter display is freely selectable
	<ul style="list-style-type: none"> • Only certain parameters (P1 to P6 pages) are displayed ^{*1} • Saving designs in the USB memory • Design data in the machine memory is protected from edits (Insertion of stitch, deletion of stitch, modification of stitch) • Detailed needle bar settings are hidden (Satin stitch (area), Satin stitch (density), Satin stitch (expansion))
	<ul style="list-style-type: none"> • All parameters except for "2. Functional limit level" on the P8 page are hidden • Saving designs in the USB memory • Design data in the machine memory is protected from edits (Insertion of stitch, deletion of stitch, modification of stitch) • Detailed needle bar settings are hidden (Satin stitch (area), Satin stitch (density), Satin stitch (expansion)) • Presser foot settings

*1 Press P6 twice to display "2. Functional limit level" on the P8 page.

- The functional limit level is set to  at shipment. Changing the functional limit level requires you to enter the password. For details, consult the distributor.

1. Turning ON/OFF the Power.....	12
1-1. Turn ON the power.....	12
1-2. Turn OFF the power.....	13
1-3. Lock the power switch.....	13
2. Start and Stop of the Machine.....	14
2-1. Start the machine.....	14
2-2. Stop the machine.....	14
3. Multi-color LEDs.....	15
4. Direct Command Switch.....	17
5. Screen Operations.....	19
5-1. Main screen.....	20
5-2. Design selection screen.....	22
5-3. Description of basic icons.....	24
6. Travel of Frame.....	26
6-1. How to move the frame.....	26
6-2. Changing the travel speed.....	26
6-3. Checking the frame position (coordinates).....	27
7. Data Input/Output.....	28
7-1. Connecting a USB memory.....	28
7-2. Connecting a LAN cable.....	29

1. Basic Embroidery Process.....	30
2. Embroidery Procedures.....	31
2-1. Saving or storing designs into the machine memory.....	31
2-2. Selecting the embroidery design (data setting).....	33
2-3. Setting of needle bar step.....	34
2-4. Confirmation of design.....	36
2-5. Setting the embroidery speed (High speed R.P.M).....	37
2-6. Checking the embroidery position (execution of trace).....	38
2-7. Starting embroidery.....	41
2-8. Completion of embroidery.....	42

Table of contents >>

3. Making Use of DCP	43
3-1. Setting items for presser foot	43
3-2. About setting operation	45
3-3. Settings on needle bar setting screen	46
3-4. Settings on manual operation screen.....	47
4. Responding to Thread Breakage	48
4-1. How to respond to a thread breakage indicator	48
4-2. Repair stitches.....	49

Chapter 3

Manual Operation

1. Moving Back or Moving Forward the Frame along the Stitches	51
1-1. Frame Back/Forward by 1-stitch unit.....	52
1-2. Frame Back/Forward by specifying the number of stitches.....	53
1-3. Frame Back/Forward by specifying the number of color change	54
2. Thread Trimming	55
2-1. ATH	55
3. Needle Bar Related Operations.....	56
3-1. Color change	56
3-2. Raising or lowering the needle bar.....	57
3-3. Stopping the needle bar at the lower dead point.....	58
3-4. Raising or lowering the presser foot.....	59
4. Various Frame Movement Operations.....	60
4-1. Moving the frame to the preset optional position.....	60
4-2. Moving the frame to the original position (manual offset).....	61
4-3. Moving the frame to the start position	61
4-4. Moving the frame to the offset position	62
4-5. Moving the frame by entering a numeric value	63
4-6. Absolute origin search.....	64
4-7. Power Resume.....	65
5. Other Operation.....	66
5-1. Turning ON/OFF the LED lamp.....	66
5-2. Automatic lubrication system.....	67
5-3. Moving up or down optional device	67

Chapter 4 Design Management

1. Design Input/Output.....	68
1-1. From the USB memory to the machine memory	68
1-2. From the machine memory to the USB memory	68
1-3. How to connect to Your PC	71
1-4. From a PC to the machine memory.....	73
1-5. From a PC to the machine memory (bar code reader).....	74
2. Deleting Designs	75
2-1. Deleting single design in the machine memory	75
2-2. Deleting plural designs in the machine memory (plural designs at once)	76
2-3. Deleting designs in the USB memory	77
3. Changing the Design Name and Storage Location	78
3-1. Renaming a design name.....	78
3-2. Changing the design storage location	79

Chapter 5 Editing Needle Bar Steps and Designs

1. Editing Needle Bar Steps	80
1-1. Setting needle bar step embroidery conditions	80
1-2. Insertion of needle bar step	83
1-3. Deletion of needle bar step.....	84
1-4. Replacing the needle bar numbers at once.....	85
2. Needle Bar Management Function	87
2-1. Setting the needle bar thread color	87
3. Editing a Design	89
3-1. Copying a design.....	89
3-2. Division of design	90
3-3. Combine of designs.....	91
4. Design Conversion	95
4-1. Scale up/down of design	95
4-2. Rotation of a design.....	97
4-3. Reverse of design.....	99
5. Setting for Repeat.....	100
5-1. Repeating a design by specifying the number of repetitions	100
5-2. Repeating a design by automatically calculating the number of repetitions	102
5-3. Reversing or rotating a design alternately	104

Table of contents >>

6. Editing Stitch Data	106
6-1. Search by stitch No.	106
6-2. Search by function code.....	107
6-3. Modification of stitch.....	109
6-4. Insertion of stitch	110
6-5. Deletion of stitch.....	112
6-6. Removal of tiny stitches	113
6-7. Arbitrary block settings	115

Chapter 6

Various Functions

1. Moving the Offset Frame	118
1-1. Outline of function	118
1-2. Registration of the offset position	120
1-3. Erasing the offset position	122
1-4. Moving the frame at an arbitrary stitch	124
1-5. Moving the frame at the color change position.....	125
2. Selecting Active Heads	126
2-1. Outline of function	126
2-2. Activating only the odd- or even-numbered heads.....	127
2-3. Specifying active heads for each needle bar step.....	128
3. Marking	131
3-1. Outline of function	131
3-2. Creating a marking design	132

1. Precautions for Maintenance	135
2. Maintenance Item List	136
3. Cleaning	137
3-1. Inside of the cylinder bed.....	137
3-2. Head and its surroundings.....	139
3-3. X-axis drive system, Y-axis drive system	140
3-4. Presser foot shaft	140
4. Lubrication	141
4-1. Rotary hook	141
4-2. Inside of head.....	142
5. Applying grease.....	143
5-1. Cylinder bed gear	143
5-2. Inside of head.....	144
5-3. Gear box.....	145
6. Inspection and Repair.....	146
6-1. Inspection of drive systems and sliding parts	146
6-2. Repair	146
7. Checking and Adjustment.....	147
7-1. Checking the needle bar lower dead point	147
7-2. Adjusting the stroke amount of the thread take-up spring	149
8. Others.....	151
8-1. Precautions to take when installing the tension base cover	151

Chapter 8 **Troubleshooting**

1. Message Screen.....	152
2. When the Machine Does not Sew Well	160
2-1. Frequent thread breakages	160
2-2. Needle breaks	160
2-3. Embroidery results not good	161
3. Power Resume after Power Failure.....	162
4. Obtaining Log Data.....	163

Chapter 9 **Appendix**

1. Improving the Sewing Finish Quality (FS Mode)	164
1-1. Outline of function	164
1-2. Sewing comparison	165
1-3. Making use of optional parts	166
2. Upgrading the Software Version.....	168
3. Specifications.....	172
3-1. Electrical specifications	172
3-2. Ambient noise level	172
3-3. Machine weight	172
4. Terminology.....	173

Chapter 1

Machine Basic Operation

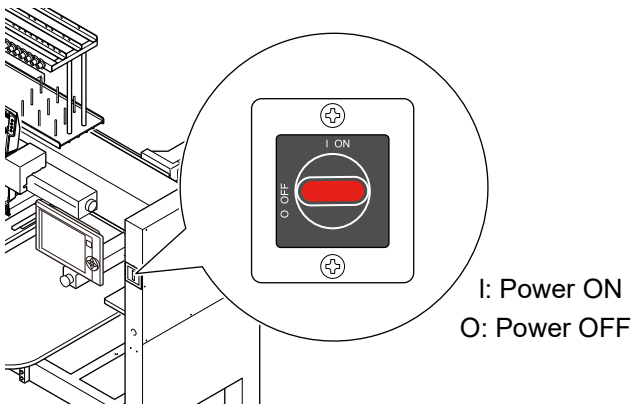

1. Turning ON/OFF the Power

The power switch is located on the right side box of the machine.



1-1. Turn ON the power

CAUTION

-  To turn ON the power again, wait for 30 seconds or more. Otherwise the system may fail to start up normally.
-  Do not turn ON the power with the USB memory connected to the operation panel. Otherwise the system may fail to start up normally.

1 Turn ON the power.

Once the power is turned ON, the system starts up and the software version screen appears.

The tension base multi-color LEDs (left and right) are lit in light blue while the system is starting up.

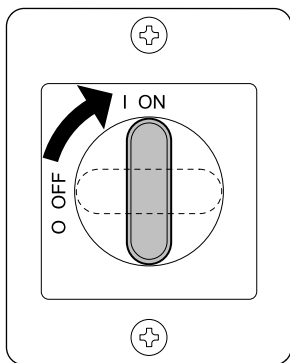

Software version

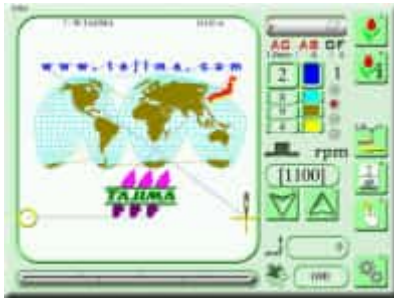

Once the system starts up, the main screen appears. In addition, the tension base multi-color LED (right) lights up in green.



- The color and lighting status of the multi-color LEDs after system start-up differ depending on the status before turning OFF the power.

For details, refer to "Chapter 1 3. Multi-color LEDs".

1-2. Turn OFF the power

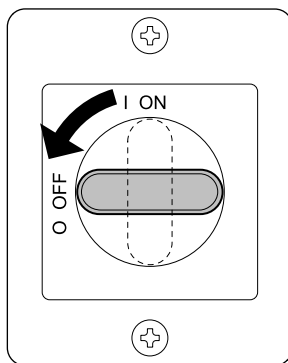

- 1 Turn OFF the power.



- Unless in an emergency, do not turn OFF the power by pressing the emergency stop switch.

1-3. Lock the power switch

You can lock the power switch to prevent the power from being inadvertently turned ON.

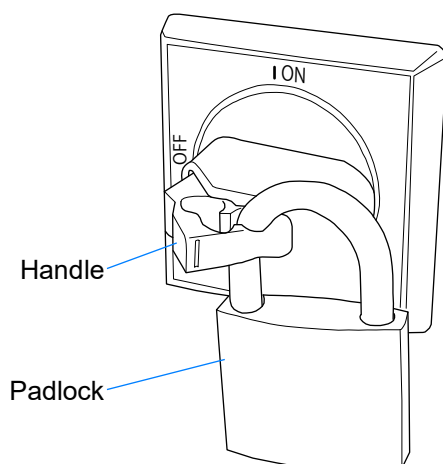

- 1 Pull out the handle.

- 2 Padlock it.



- Use a padlock available on the market.

2. Start and Stop of the Machine

To start and stop the machine, use the start/stop switch located on the front face of the machine.

⚠ CAUTION

! Before starting the machine, pay enough attention to the surrounding safety. You may be injured by a moving needle bar or frame.

2-1. Start the machine

[To start the machine immediately]

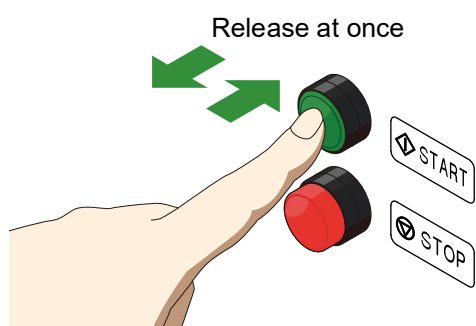

Press the start switch and release it immediately. The needle bar moves up and down slowly (in an inching manner) and then the machine starts operation.



- You can configure the number of inching times (during startup) with a parameter. For details, refer to the separate "Parameter Settings" manual.

[To start the machine gradually]

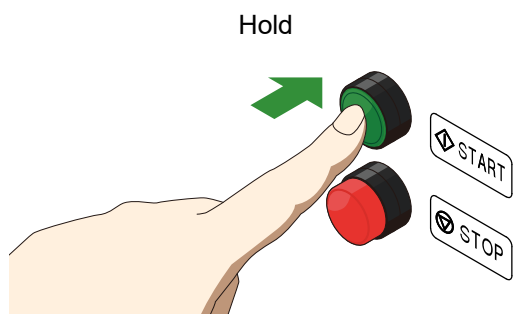

Press the start switch and hold it in that position. While you are holding it, the needle bar moves up and down slowly (in an inching manner).



- When you release the start switch, the machine starts normal embroidery operation.

2-2. Stop the machine

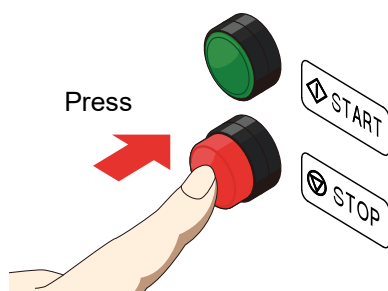

Press the stop switch. The machine stops operation.



- You can use the start/stop switch, not only to start and stop the machine, but also to move the frame along the stitches for repair stitching at thread breakage (Frame Back/Frame Forward). For details, refer to "Chapter 3 1. Moving Back or Moving Forward the Frame along the Stitches".

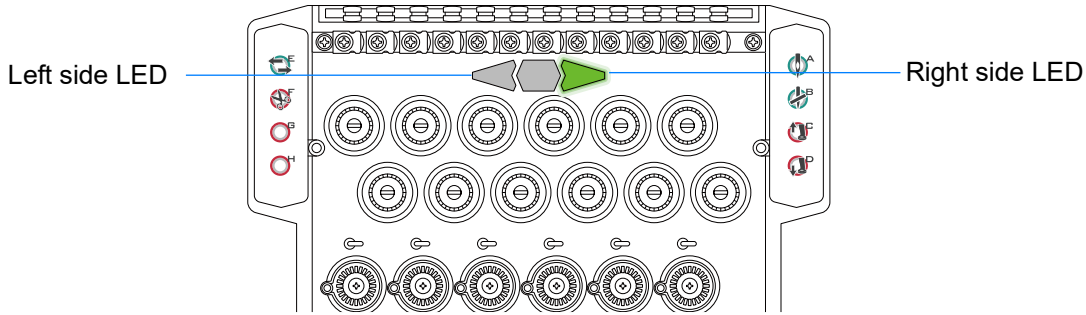

3. Multi-color LEDs

The tension base multi-color LEDs light up or blink in a particular color to indicate the machine operation status or the occurrence of thread breakage.



LED	Color	Condition
Right/ left	Lit in light blue 	The both LEDs are lit during start-up until the main screen appears.
	Unlit 	The both LEDs go off when the head is suspended.
Right side	Lit in green 	Lights when embroidery is available or in progress.
	Blinking in green 	During Frame Back (i.e., while moving back the frame along the stitches), the LED blinks if the head is one without thread breakage.
	Lit in red 	Lights up if the upper thread is broken.
	Blinking in red 	Blinks if the under thread is broken.
	Lit in orange 	Lights up if the start method of sewing after Frame Back is set to "return stitching" and "repair stitching".*1

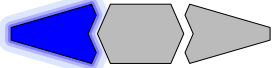
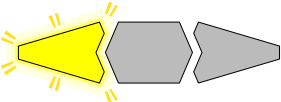



*1 To change the start method of sewing after Frame Back, use the A switch on the tension base. For details, refer to "Chapter 1 4. Direct Command Switch".

Left side	<p>Lit in blue</p> 	<p>Lights up when the frame is moved manually while the operation is stopped during embroidery. Illumination indicates that the frame is not in its original position (i.e., the position when the operation was stopped).</p>
	<p>Blinking in yellow</p> 	<p>Blinks when there is an abnormality in the presser foot motor or other components.</p>
	<p>Lit in yellow</p> 	<p>Lights up when various adjustment items are selected in parameter (85. Machine adjustment). [Examples]</p> <ul style="list-style-type: none"> • 18. Presser foot lower dead point adjustment • 19. Presser foot installation

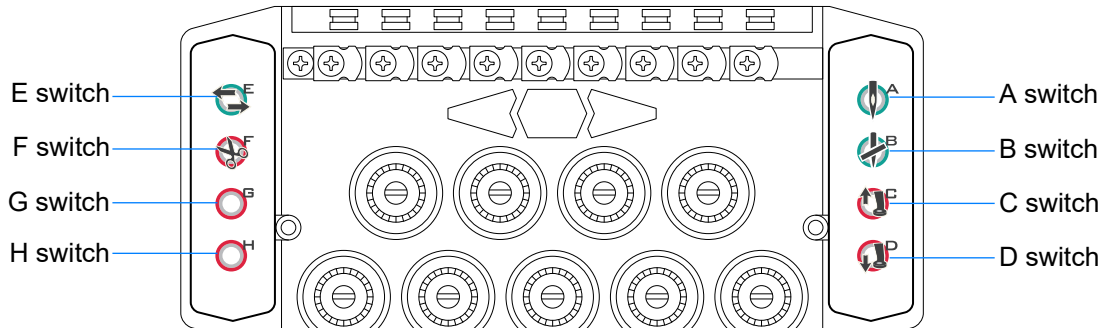

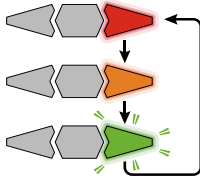

4. Direct Command Switch

The following functions are assigned to the direct command switches on the left and right sides of the tension base.



Switch	Function
<p>A switch</p> 	<p>Changes the head to "active".</p> <p>The multi-color LED lighting color switches every time you press the A switch after performing Frame Back by the thread breakage.*1</p>  <p>Red: The machine performs repair stitching.</p> <p>Orange: The machine performs return stitching and repair stitching.</p> <p>Blinking in green: The machine does not perform repair stitching.</p>
<p>B switch</p> 	<p>Changes the head to "suspended".</p> <p>For the suspended head, the multi-color LEDs go off, and the needle bar will not move even if you start the machine.</p>
<p>C switch</p> 	<p>Hold down this switch (for 1 second) to move up the needle bar.</p>
<p>D switch</p> 	<p>Hold down this switch (for 1 second) to move down the needle bar.</p>
<p>E switch</p> 	<p>Toggles between Frame Back and Frame Forward.</p>

*1 Even when you are not performing Frame Back, the multi-color LED lighting color changes every time you press the A switch.

Switch	Function
<p>F switch</p> 	<p>Press and hold this switch for 1 second to trim the upper and under threads 1 second after releasing your hand.</p>
<p>G switch</p>  <p>H switch</p> 	<p>Parameter settings allow you to assign any function below to the G and H switches respectively.</p> <p> Pressing and holding the G or H switch will cause the warning buzzer to sound and releasing the switch will execute the selected function.</p> <ul style="list-style-type: none"> • This function can be operated only when the machine is stopped at the main shaft fixed position and the main screen is displayed. • When LED at the tension base is unlit, this function does not work. <ul style="list-style-type: none"> • 1 stitch dropping^{*1} • Trace (High) • Trace (Low) • Presser foot Up at trace (High) • Presser foot Up at trace (Low) • Offset return • Manual offset • Frame travel to optional position • Start position return • Needle bar Up • Under thread trimming ATH • Stop at lower dead point^{*2} • Reset of Preset Halt by Stitches^{*3} • Reset of Preset Halt by Data^{*3} • Reset of Preset Halt by Designs^{*3} • Light ON/OFF • ATH at repair stitches (ON*/OFF)

*1 When the G or H switch is pressed and held, the needle bar will drop one stitch for this head only.

If the multi-color right LED is blinking in green (not at the time of repair stitching), "1 stitch dropping" cannot be operated.

*2 When raising the needle bar, operate the operation panel.



*3 When you stop this machine during embroidery and press the G switch or H switch, the preset halt value will be reset, and the value of the parameter "6 Total Stitch Counter" will be cleared.

5. Screen Operations

Use the operation panel to perform operations for embroidery and configure various settings.

The touch panel allows you to switch the display screen and configure various settings by lightly touching the icons displayed on the screen.

CAUTION

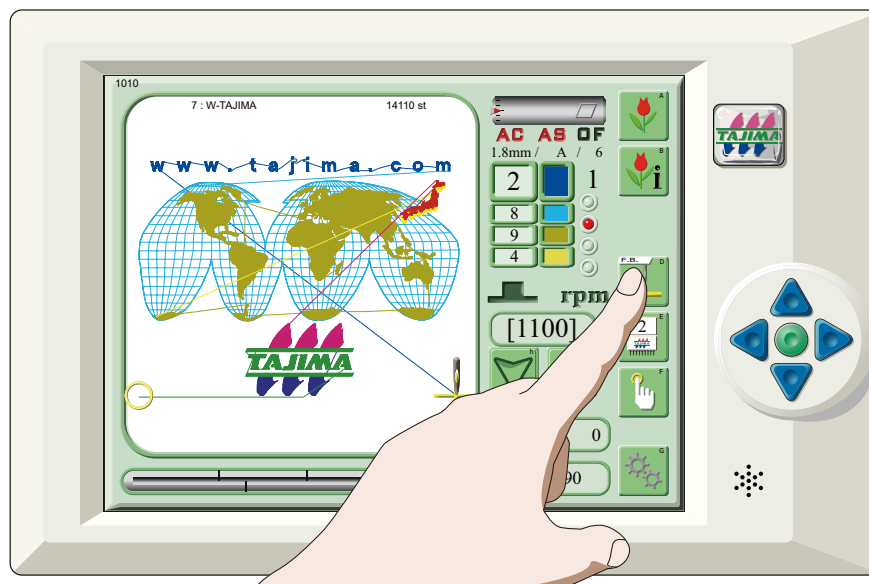

-  Touch them with your finger.
-  Do not press hard on the touch panel or do not press on the touch panel with pointed objects. Doing so may damage the panel.





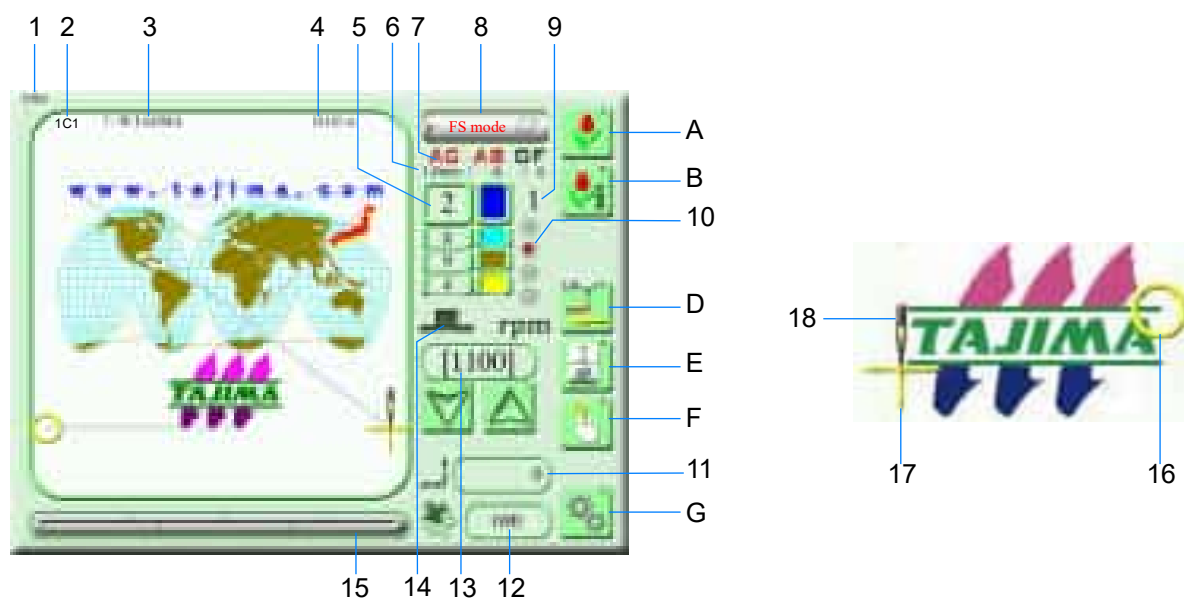

5-1. Main screen

The main screen appears once you turn ON the power and the system successfully starts up. You can begin to configure various settings and operate the machine from the main screen.



No.	Description	No.	Description
1	Screen number	7	AC (Auto Color Change), AS (Auto Start), and OF (Automatic Offset) setting status (displayed in red if the setting is enabled)
2	Stop factor (displayed during stop of the machine)	8	FS mode setting status (displayed as "FS mode" when enabled) and currently selected frame type  Border frame  Tubular goods frame  Cap frame
3	Design name	9	Current needle bar step No.
4	Total number of stitches of design	10	Setting status of offsetting at automatic color change (displayed in red if enabled)
5	Needle bar No. of the current step	11	Current number of stitches
6	Presser foot settings Blue characters: The current stitch is in an arbitrary block. Red characters: Presser foot settings have been changed per step (needle bar setting screen). ^{*1}	12	Cumulative embroidery count (even if the power is turned OFF/ON, counting will continue.)

^{*1} All the characters will be red if a design with registered presser foot settings is entered into the machine's memory, and then the data is set.

13	High speed	A	Navigate to the design selection screen
14	<p>Current main shaft angle</p>  Fixed position  "Main shaft brake" is set to "No".  Outside of range of fixed position  Each long press (2 seconds or more) toggles the main shaft brake ON/OFF.	B	Navigate to the detailed information screen of design
15	Embroidery progress (indicated by red scale marks)	D	Navigate to the current FB (Frame Back)/FF (Frame Forward) setting condition and FB/FF screens
16	Embroidery end point	E	Navigate to the manual color change screen (the displayed number is the current needle bar No.)
17	Embroidery start point	F	Navigate to the manual operation screen
18	Current embroidery position	G	Navigate to the parameter setting screen

5-2. Design selection screen

This screen lets you save, select, or edit your design.

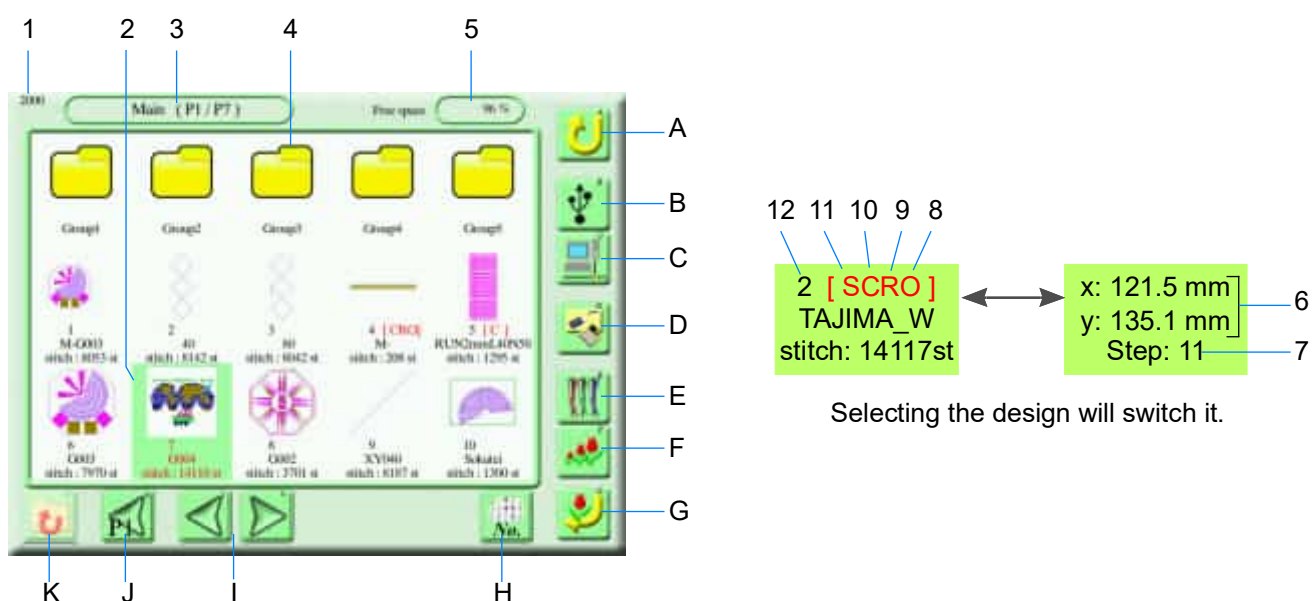

Selecting the design will switch it.

No.	Description	No.	Description
1	Screen number	A	Back (return to the previous screen)
2	Design stored in the machine memory	B	Navigate to the USB memory screen
3	Screen page	C	LAN cable connected
4	Design storage folder (You cannot change the folder names "Group1" to "Group5")	D	Navigate to the design edit screen
5	Machine memory capacity (40,000,000 stitches) (Free space percentage (%) is displayed. The remaining number of stitches is displayed instead if the free space is 20% or lower.)	E	Navigate to the needle bar selection screen
6	Design size	F	Navigate to the design enlargement/reduction and repeat screens
7	Number of needle bar steps	G	Save Changes (navigate to the data set screen)
8	With setting of automatic offset	H	Rearrangement of designs (Designs are reordered every time you touch the icon.) No.: In the ascending order of machine memory numbers Name: Alphabetical design name order Time: Updating order
9	With setting of repeat		

10	With settings of scaling up or down or rotation of the design	I	Navigate to the previous or next page
11	Indicates that the embroidery condition for the needle bar step has been changed	J	Back (return to the first page)
12	Machine memory No. (When you store a design in the machine memory, the next available machine memory No. is assigned)	K	Back (return to the "Main" folder screen if the "Group" folder is selected)



- The icon C is not displayed if a LAN cable is not connected.
- When there is no design in the machine memory, the icons D, E, and F are not displayed.

5-3. Description of basic icons

There are common icons you can use to switch the display screen, save settings, or enter alphanumeric characters.

Common icons

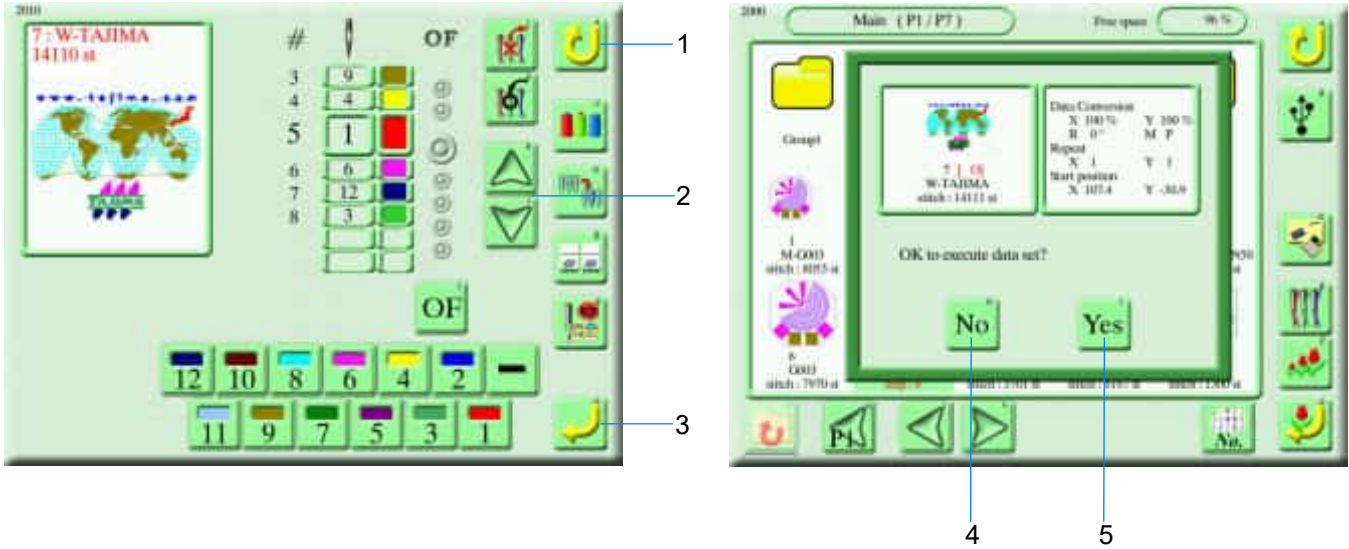

No.	Description
1	The screen will return to the previous screen by one.
2	Move a step up and down.
3	Put the setting into effect.
4	Cancel the operation and disable the setting.
5	Save or enable the setting.

■ Entering alphanumeric characters

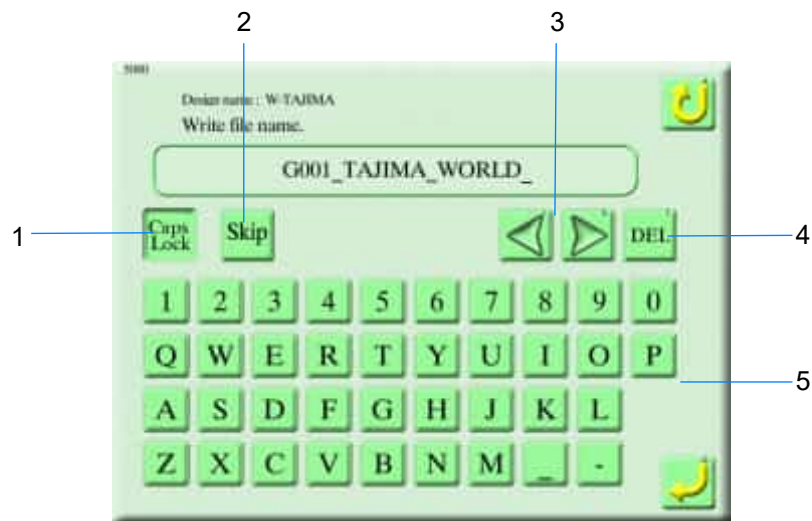

No.	Description
1	Toggle between uppercase and lowercase.
2	<p>Skip : If there is a design with the same name in USB memory, it will be overwritten and saved.</p> <p>Skip : If there is a design with the same name in USB memory, the new design will be saved under the file name appended with (1) at the end.</p>
3	Move the cursor.
4	Delete the character at the cursor position.
5	Enter a character by pressing the corresponding icon.

6. Travel of Frame

To manually move the frame, use the frame travel keys on the operation panel.

To change the frame travel speed, use the speed switching key.

6-1. How to move the frame

While you are holding down one of the frame travel keys, the frame keeps moving in that direction.

CAUTION

- Do not place your hands on the table or near the perimeter of the frame. The frame moves and may cause injury to your fingers and hand.

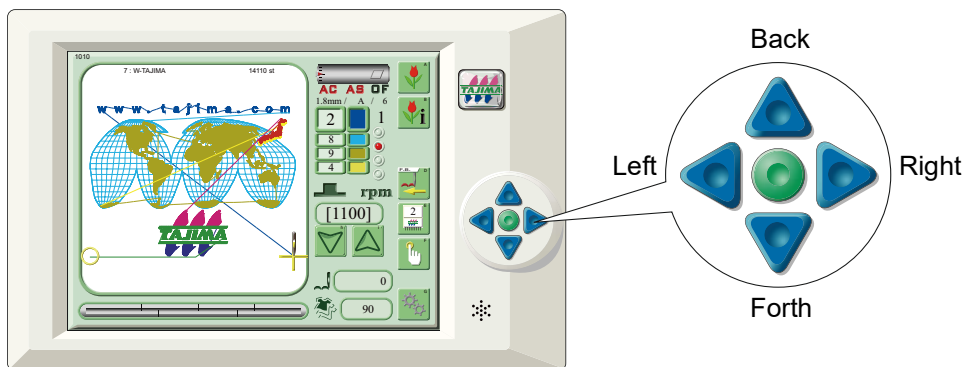

- The machine stops and a message screen appears when the frame reaches the limit of the embroidery space. Cancel the stop code and change the embroidery position.
- If you have moved the frame by hand with the power OFF, turn ON the power and execute an absolute origin search. For more information on absolute origin search, refer to "Chapter 3 4-6. Absolute origin search".

6-2. Changing the travel speed

You can toggle between the low and middle frame travel speeds by pressing the speed switching key.

Also, you can move the frame at high speed by pressing one of the frame travel keys while holding down the speed switching key.

Low speed	Middle speed	High speed
Press the speed switching key to turn off its back light, then press one of the frame travel keys.	Press the speed switching key to turn on its back light, then press one of the frame travel keys.	Press one of the frame travel keys while holding down the speed switching key.

6-3. Checking the frame position (coordinates)

You can check the current frame position (coordinates) on the manual operation screen.



- To display the manual operation screen, press  on the main screen.

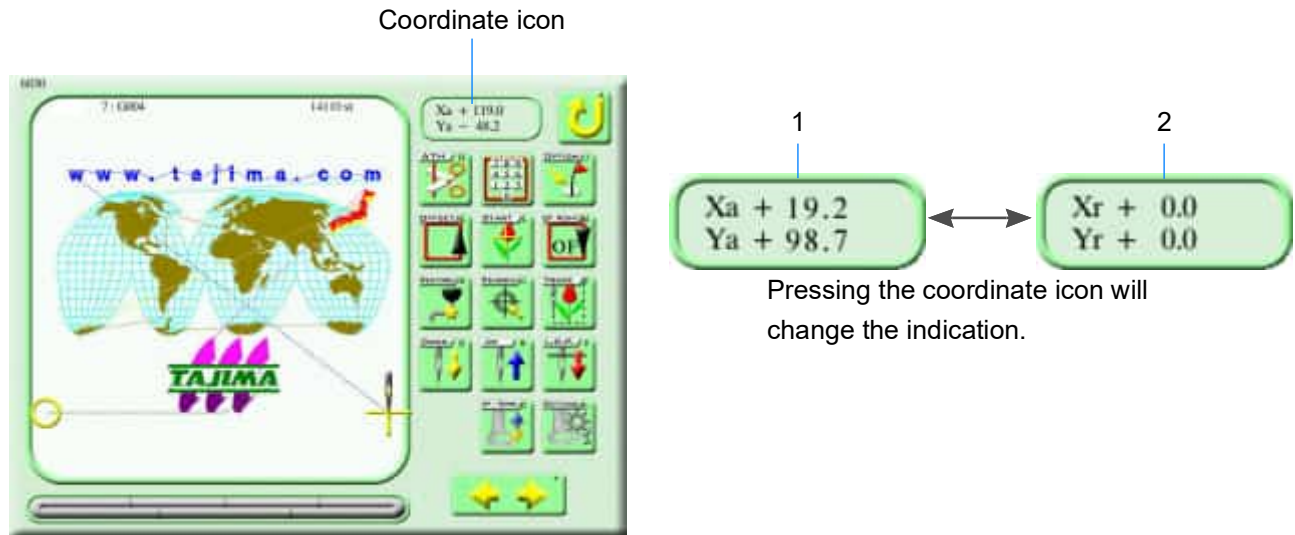

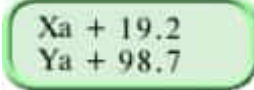
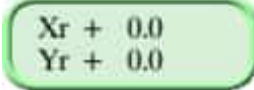
No.	Coordinate icon	Description
1		The coordinates based on the absolute origin of the frame appear.
2		The coordinates based on the start position of the design whose data is set appear.



- If the coordinates are not correctly displayed, the absolute origin may not be correctly set. Execute absolute origin search. For more information on absolute origin search, refer to "Chapter 3 4-6. Absolute origin search".







7. Data Input/Output

The machine is equipped with a USB port on the right side of the operation panel and a LAN port on the right side of the machine.

7-1. Connecting a USB memory

Insert a USB memory into the USB port on the operation panel. You can use a USB memory to input/output designs and upgrade the software version.

CAUTION

-  Do not turn ON the machine power with a USB memory inserted into the operation panel. Otherwise the system may fail to start up normally.
-  Do not insert a USB memory if it contains dirt or dust inside the connector.
-  Do not insert or remove a USB memory while the machine is running.
-  Do not forcibly insert a USB memory.
-  Insert a USB memory slowly.
-  Insert a USB memory straight into the USB port. Diagonally inserting a USB memory may cause the connector to interfere with and possibly destroy the internal circuit board.
-  Do not operate a machine until at least five seconds elapses after you insert a USB memory.

USB memory

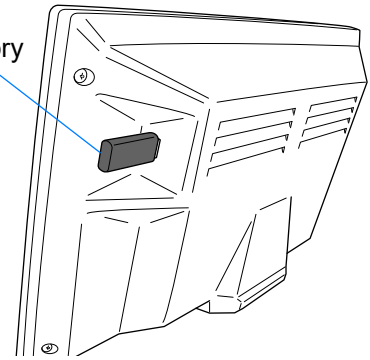

- The machine does not work with USB memories of certain types and capacities.
- Use a recommended USB memory (i.e., a USB 2.0-compliant USB memory formatted in the FAT/FAT32 format).

7-2. Connecting a LAN cable

Connect a LAN cable to the LAN port on the right side box, which is located on the back of the machine. Use the LAN cable to connect the machine to your PC via LAN.

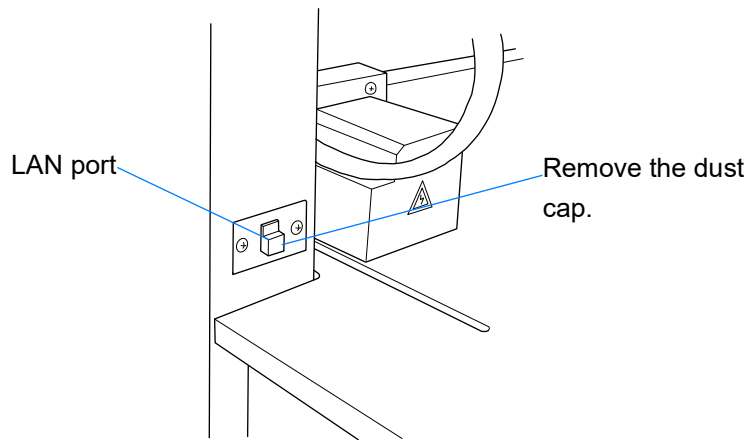

- To connect the machine via a router to your PC, use a straight cable available on the market.
- To directly connect the machine to your PC, use a cross cable available on the market.
- For more information on connecting the machine to your PC, refer to "Chapter 4 1-3. How to connect to Your PC".

Chapter 2

How to Embroider

1. Basic Embroidery Process

For details, refer to the corresponding guides and chapters.

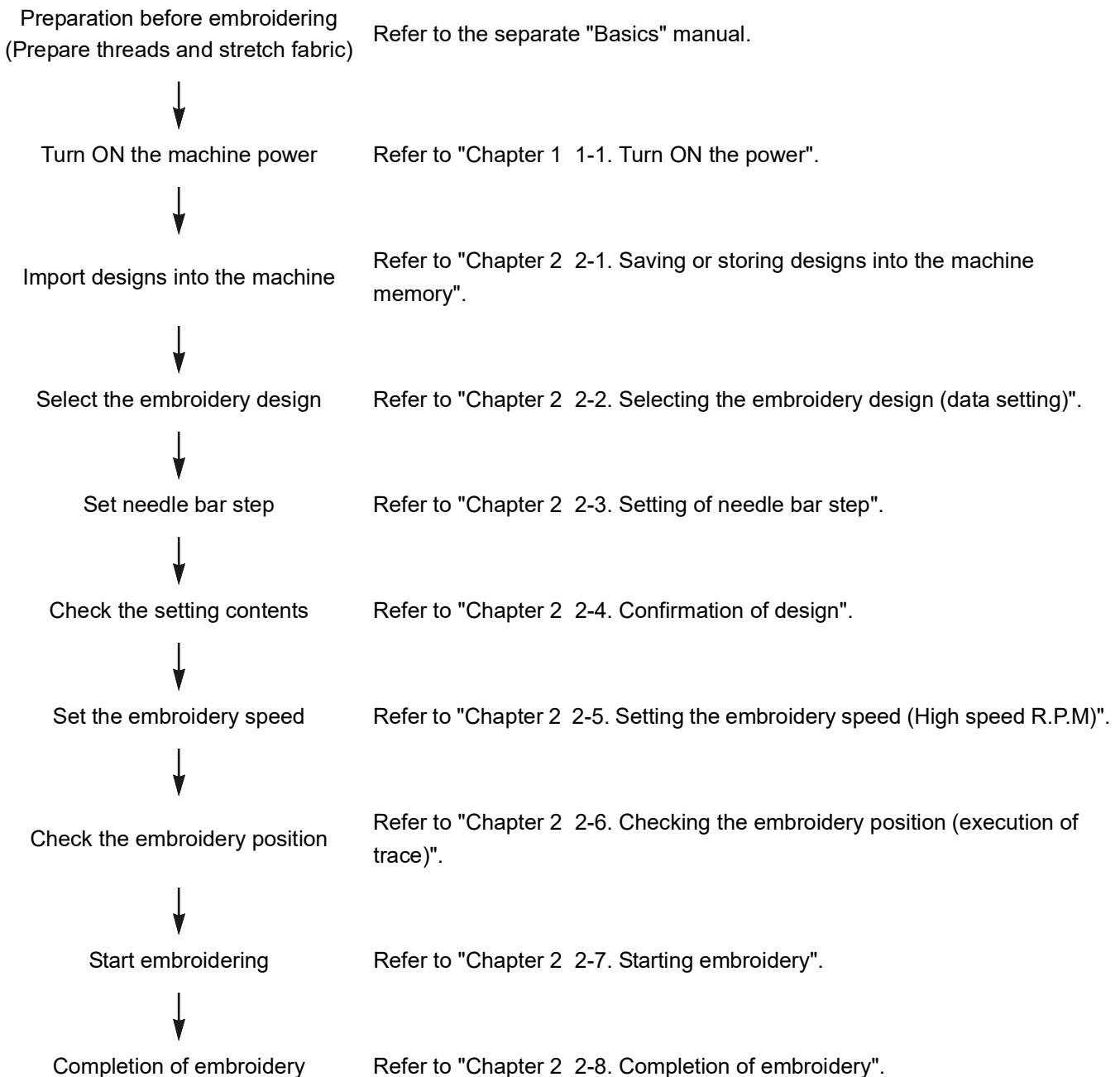

2. Embroidery Procedures

This section describes the procedures for importing the desired designs into the machine memory and starting and completing embroidery.

2-1. Saving or storing designs into the machine memory

Save the embroidery design in the machine memory by one of the following methods:

- A USB memory
- Your PC
- A bar code reader

The following example shows how to select two designs from a USB memory and store them in the "Main" folder in the machine memory.



- The "Main" folder can store up to 200 designs and the folders from "Group1" to "Group5" can each store up to 90 designs (thus up to 650 designs in all). The maximum number of designs you can store may, however, be smaller than mentioned above depending on the free space of the machine memory.
- The design data which was embroidered once, the start position is stored in the design data as the condition data.
- The machine memory can store designs from your PC and bar code reader as well. For details, refer to "Chapter 4 1-4. From a PC to the machine memory".

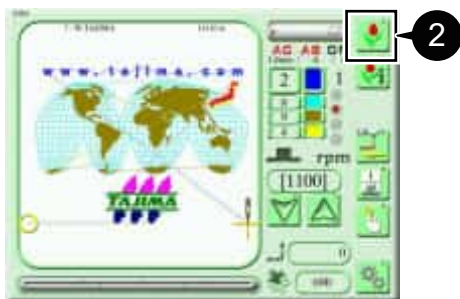

1 Insert a USB memory containing designs into the USB port on the operation panel.

2 Press  on the main screen.

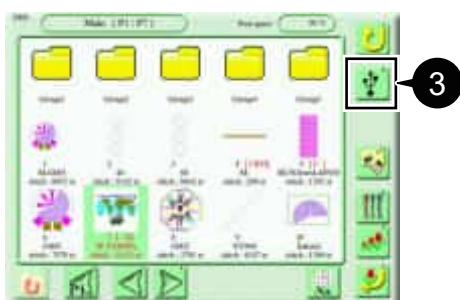

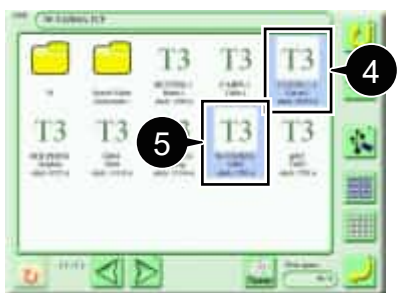

3 Press .



4 Select the first desired design.



- All designs are selected when  pressed.
- All designs are deselected when  pressed.

5 Select the second desired design.



6 Press .



- If the maximum number of designs you can store is exceeded or the machine memory is short of free space, error No.2BA appears.

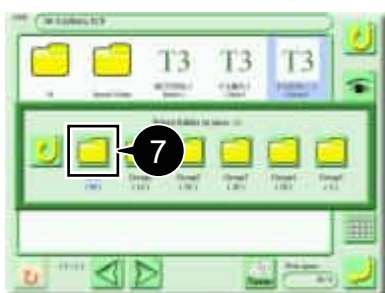

7 Press  "Main".

The selected designs are stored into the machine memory.

■ About the display of a design

A design saved on the USB memory is displayed on the operation panel, as shown below.

T ← Saving format of design
G0003 ← File name (indicated on your PC)
MADELENE ← Design name
stitch:30034st ← Number of stitches of design

Saving format of design

- T: TAJIMA format (DST)
- T2: TAJIMA binary format (TBF)
- T3: TAJIMA integrated file (TCF)

Depending on saving format of the design, the design except above one will be displayed.

2-2. Selecting the embroidery design (data setting)

Select the embroidery design so that the machine can start embroidery.

CAUTION

 Do not put your hand on the table when you operate the machine. The frame moves and may cause injury to your fingers and hand.

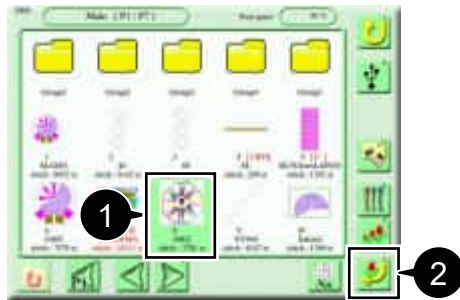

1 Select the embroidery design on the design selection screen.

2 Press .

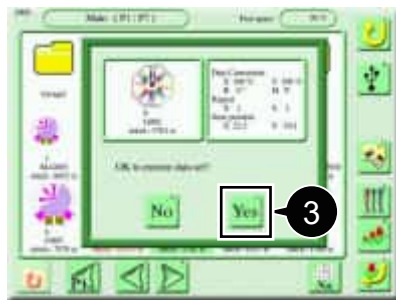

3 Press .

The design data is set.

■ If the design contains the start and the offset positions

If the design contains the "start position" (i.e., the previous embroidery start position of the selected design) and "offset position", the frame travel message screen appears after the data is set.

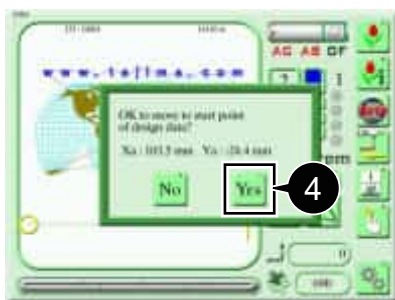

4 Press .

The frame moves to the start position or the offset position.

If you select "No", the current frame position will be the design start position.



- For more information on Automatic Offset settings, refer to "Chapter 6 1. Moving the Offset Frame".

■ If the design contains a message

If the design contains a message created with DG by Pulse (optional design creation software), the message will appear after you set the data and upon completion of embroidery. For more information, refer to the user's manual for DG by Pulse.

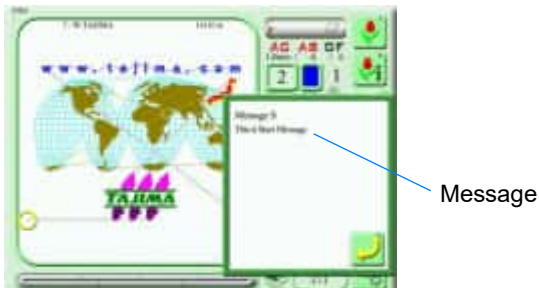

- Writing a message into the design data (*.TCF) requires DG15 by Pulse or later.

2-3. Setting of needle bar step

Set a needle bar to use (sewing order) for each needle bar step of the selected design.

The machine performs embroidery while automatically changing the color based on those settings.

The following example shows how to assign the needle bar No. 4 to the needle bar step 1 and the needle bar No. 6 to the needle bar step 2.



- If the "Auto Color Change" parameter is set to "No", the machine will not automatically change the color. For details, refer to the separate "Parameter Settings" manual.
- This procedure is not required when a needle bar step setting is included as the condition data in the design.

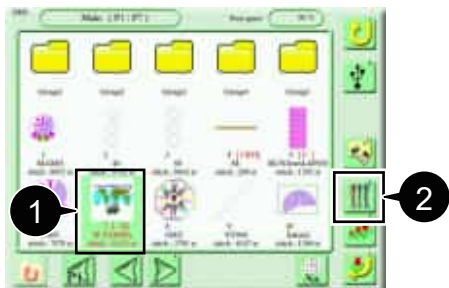

1 Select the desired design on the design selection screen.

2 Press .

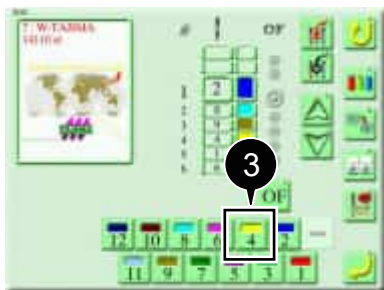

3 Press .

Needle bar No. 4 is assigned to the needle bar step 1 and the screen proceeds to the next needle bar step.



- To select an arbitrary needle bar step,

Press  .

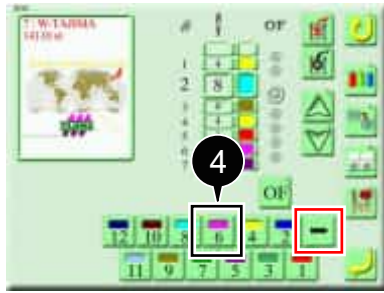

4 Press .

Needle bar No. 6 is assigned to the needle bar step 2 and the screen proceeds to the next needle bar step.



- The selection of needle bar step 2 or later will display the



(red frame). Pressing  for the needle bar

step 3 will display    and repeat needle bar steps 1 and 2 only.

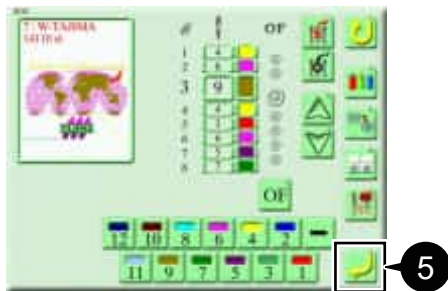

5 Press .

Now you are done configuring the needle bar steps.

1
2
3
4
5
6
7
8
9

2-4. Confirmation of design

You can check the settings of the size and orientation of the design whose data is set.

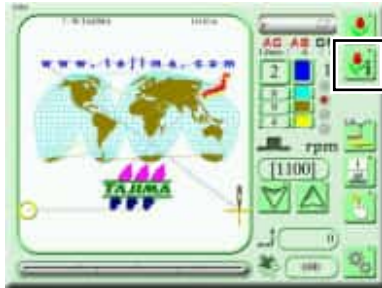

1 Press



2 To check the settings, use the following confirmation screen.

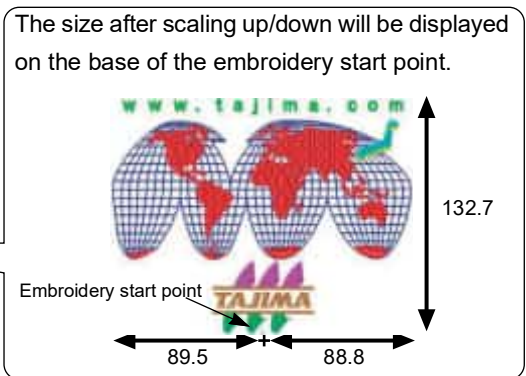
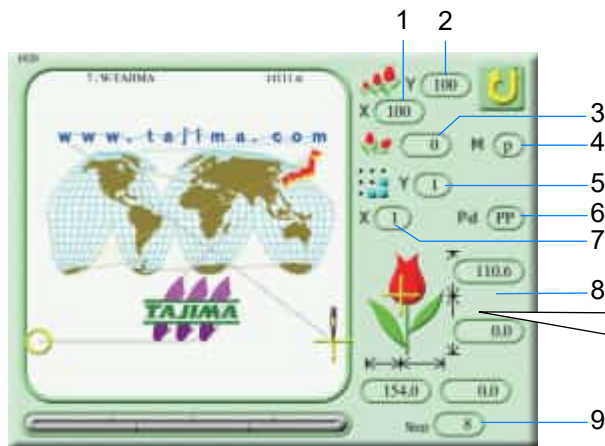

No.	Description	No.	Description
1	Scale ratio of design (Horizontal)	6	Design repeat pattern
2	Scale ratio of design (Vertical)	7	Number of repeats of design (Horizontal)
3	Rotating angle of design	8	Size of design (mm)
4	Reversion of design (p = do not reverse, q = reverse)	9	Number of needle bar steps of design
5	Number of repeats of design (Vertical)		



• For setting details, refer to "Chapter 5 4-1. Scale up/down of design".

2-5. Setting the embroidery speed (High speed R.P.M)

You can set the upper limit of the embroidery speed.

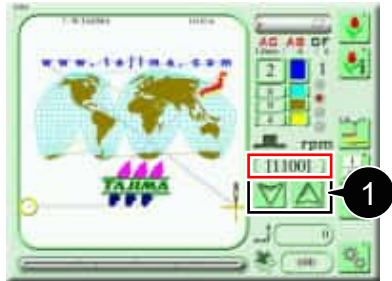

During operation, the embroidery speed changes according to the stitch length of the design without exceeding the configured upper limit.



- 1 Press   to set the speed upper limit.

The new setting appears in the red box.



- The value increases or decreases continuously when   pressed and held.
- You can configure the setting in the middle of embroidery.

2-6. Checking the embroidery position (execution of trace)

Before starting embroidery, you can move the frame along the contour of the design (as referred to as "tracing") to check if the embroidery position (start position) is correct and check if the design will fall within the embroidery space.

Outline of trace

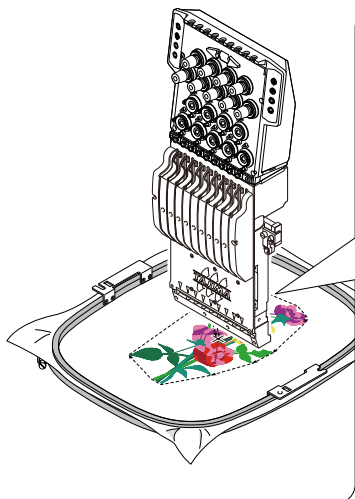

Tracing starts at the start position and proceeds along the contour of the design.

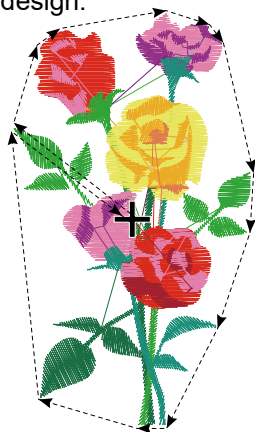

⊕ : Start position

[If the Automatic Offset setting is enabled for the frame]

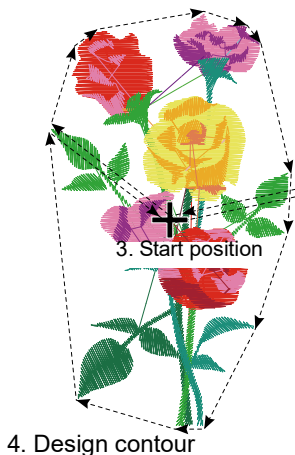

- The machine will trace the following in this order:
1. Offset position
 2. Offset middle position
 3. Start position
 4. Design contour
 3. Start position
 2. Offset middle position
 1. Offset position

[If the repetition setting is enabled for the design]

The machine will trace whole designs after tracing the first design.



- For more information on Automatic Offset settings, refer to "Chapter 6 1. Moving the Offset Frame".
- For more information on repetition settings, refer to "Chapter 5 5. Setting for Repeat".
- If the start position is not correct, the frame stops during tracing and error No.225 appears.
Correct the start position and perform tracing again.

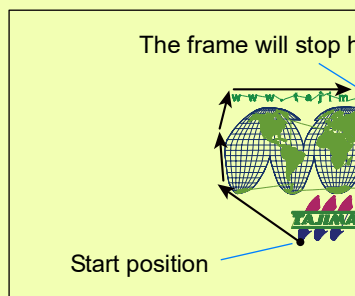

The frame will stop here.

Start position

It is not possible to embroider this part.

How to operate

CAUTION

- Do not put your hand on the table when you operate the machine. The frame moves and may cause injury to your fingers and hand.

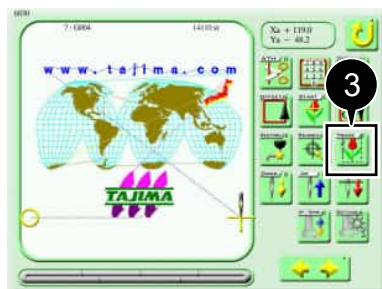
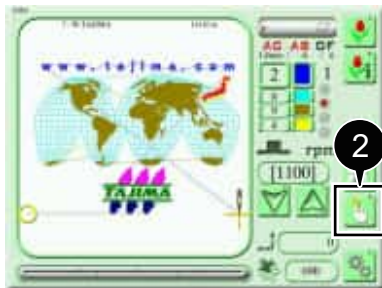
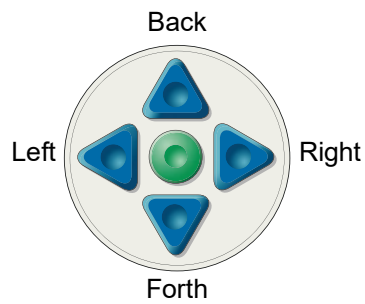

- Using the frame travel key, move the frame to the start position.



- For more information on moving the frame, refer to "Chapter 1 6-1. How to move the frame".

- Press  on the main screen.

- Press .

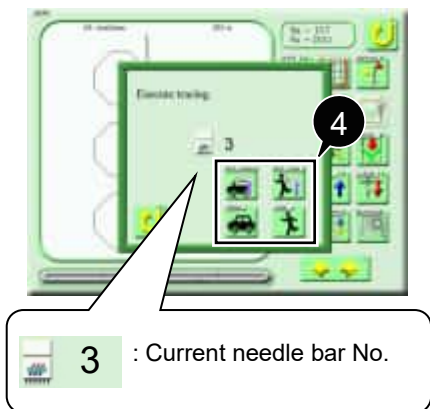

4 Execute Tracing.



: High-speed tracing with the presser foot raised



: Low-speed tracing with the presser foot raised

- The position where tracing was executed is stored as the start position.
- To suspend tracing, stop the machine. To resume tracing, follow instructions on the screen.

The icon display will be added if "Presser Foot Up at Tracing" is set to "No" in the parameter.



: High-speed tracing with the presser foot height as it is.



: Low-speed tracing with the presser foot height as it is.

2-7. Starting embroidery

CAUTION

-  Before starting embroidery, pay enough attention to the surrounding safety. You may be injured by a moving needle bar or frame.

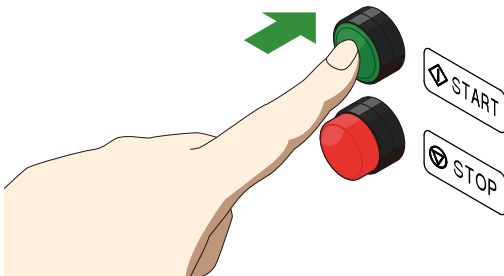
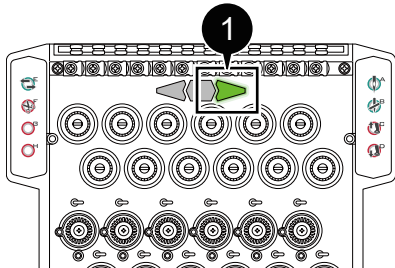

- 1 Check that the multi-color LED (on the right side) of the embroidery head is lit in green.



- If it is not lit, press the A switch on the tension base.

- 2 Press the start switch.
The needle bar moves up and down slowly (in an inching manner) and then embroidery starts.



- For more information on operating the start/stop switch, refer to "Chapter 1 2. Start and Stop of the Machine".

Checking the progress of embroidery

The progress of embroidery is indicated by red scale marks in the lower part of the main screen.

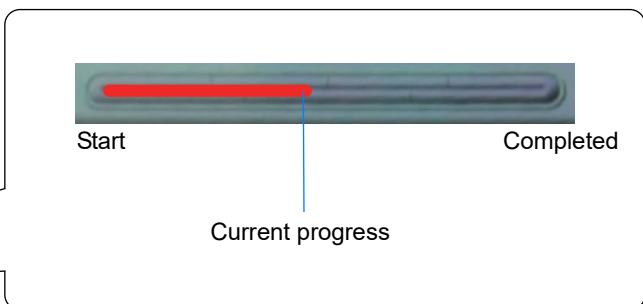
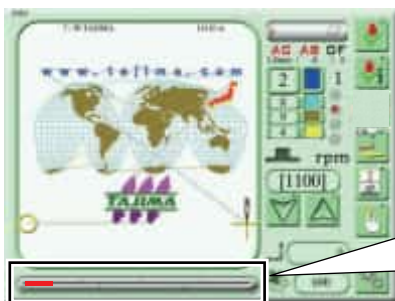

How to resume embroidery after moving the frame

After you manually move the frame during embroidery, you can resume embroidery by one of the following methods:

- Return the frame to the original position using manual offset operations and then resume embroidery using the start switch.
- Resume embroidery by pressing the start switch. (This method is only available if the "Return Frame after Frame Travel" parameter is set to "Yes".)



- For more information on manual offset, refer to "Chapter 3 4-2. Moving the frame to the original position (manual offset)".
- If the "Return Frame after Frame Travel" parameter is set to "No", the frame does not return to the original position and embroidery resumes from the position the frame moved to. The parameter is set to "No" by factory default. For details, refer to the separate "Parameter Settings" manual.

2-8. Completion of embroidery

Upon completion of embroidery, the frame moves to the start position and the machine stops operation.



- If the "Automatic origin return" parameter is set to "Yes", the frame moves to the design start position upon completion of embroidery. If it is set to "No", the frame stops at the same position as when embroidery is completed. For details, refer to the separate "Parameter Settings" manual.

CAUTION

-  Do not put your hands or anything else on the table after embroidery. The frame moves and may cause injury to your fingers and hand.

The frame moves to the start position

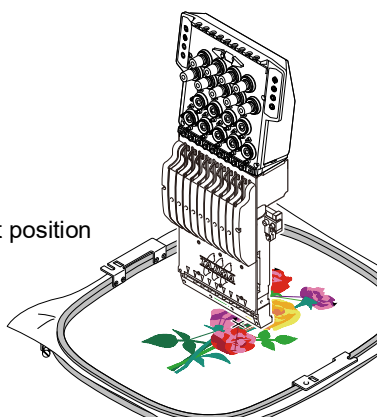

[If the Automatic Offset setting is enabled for the frame]

Upon completion of embroidery, the frame moves to the offset position and the machine stops operation.



- For more information on Automatic Offset settings, refer to "Chapter 6 1. Moving the Offset Frame".

The frame moves to the offset position

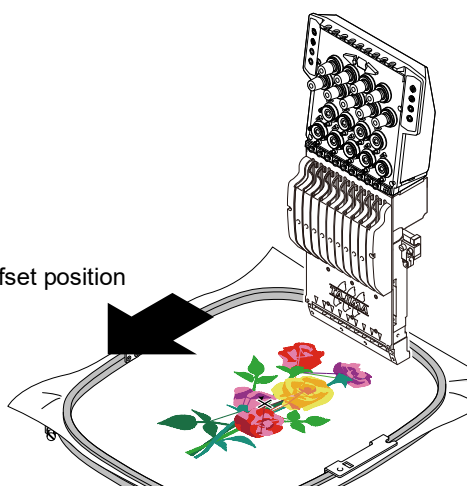

3. Making Use of DCP

The Digitally Controlled Presser Foot (DCP) is a function that uses a motor and digitally controls the presser foot to press the fabric.

It is possible to set the height and stroke of the presser foot according to the type and thickness of the fabric, which reduces the rattling of the fabric and achieves more stable sewing.

In addition, by using the touch panel, the DCP allows ease of presser foot adjustments, which operators have been made manually.

3-1. Setting items for presser foot

Although presser foot settings are made with parameters in advance, you can change the following settings according to the type and thickness of the fabric.

■ Settings for presser foot lower dead point

Set the height from the needle plate to the presser foot lower dead point.

Make settings with consideration of the thickness of the fabric.

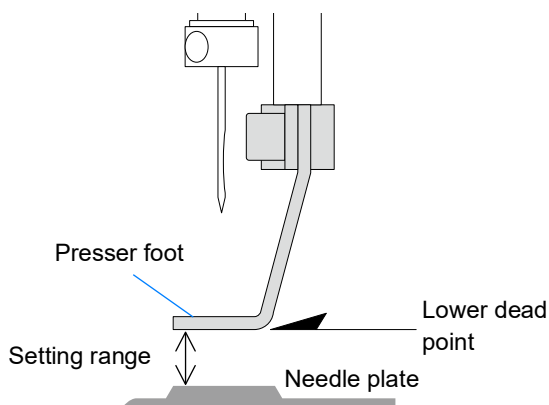

⚠ CAUTION

- Do not set the value lower than the thickness of the fabric. Doing so may cause the presser foot to come in contact with a part where the fabric is piled up and raised, and the machine may be damaged.

Setting range: 0.3 to 6.3 mm

■ Settings for presser foot stroke

Set the presser foot stroke amount.

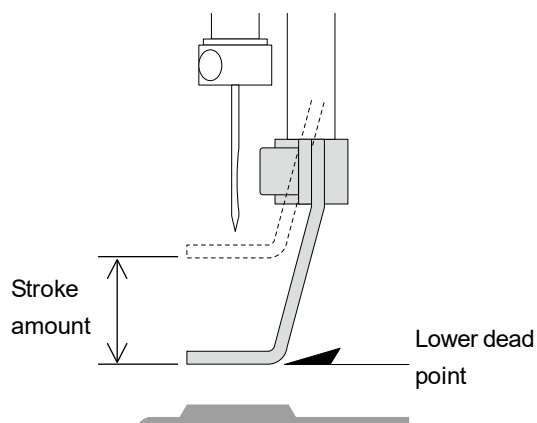

- If the stroke becomes larger, sewing mistakes can occur easily. Set the value by checking the sewing condition.

Setting range: Functional limit level 1: 5.0 to 22.0 mm

Functional limit level SEL: 2.0 to 22.0 mm

■ Settings for presser foot timing

Set timing when the presser foot starts to move down.

The smaller the setting value, the faster the moving down timing of presser foot. The larger setting value causes the delay of the timing.

The mutual relation among the lower dead point, the stroke, setting range of timing of the presser foot and the locus of the needle is shown roughly in the figure as reference information.

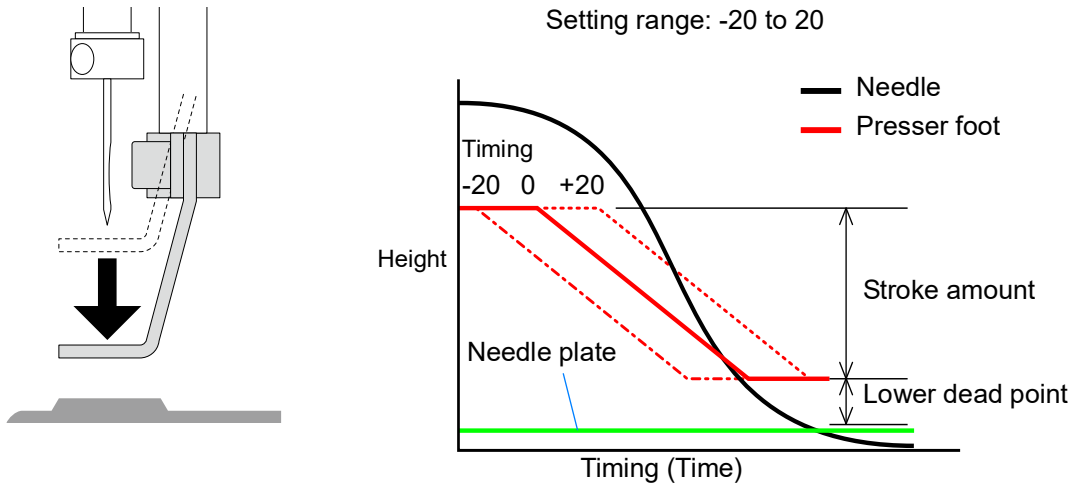

■ Settings for presser foot F. B. lower dead point

Set the height from the presser foot lower dead point to the presser foot when performing Frame Back.

Setting range: 5.0 to 22.0 mm, R. (retracting position)

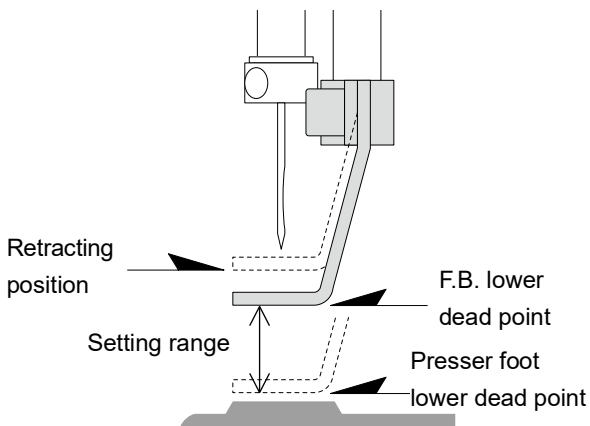

3-2. About setting operation

Presser foot settings are possible with any of the following three screens: Parameter setting screen, needle bar setting screen, and manual operation screen.

In the case of duplicated settings, those set in the needle bar setting screen will take precedence, followed by those set in the parameter setting screen or manual operation screen.

■ Settings on parameter setting screen

Make presser foot settings that serve as the basis of the entire machine or specified needle bar.

These are basic settings, so the machine will continue sewing with the same settings regardless of design changes. Initial settings are registered in advance in parameters.

Furthermore, if settings are made on the needle bar setting screen, settings on the needle bar setting screen take precedence over parameter settings.

■ Settings on needle bar setting screen

Make presser foot settings per step for the selected design.

You can make presser foot settings that vary with each step for the same needle bar.

Values set on the needle bar setting screen are saved in design data.

■ Settings on manual operation screen

You can change presser foot settings during embroidery.

Make presser foot settings for the needle bar currently being used.

Like parameter settings, the machine will continue sewing with the same settings regardless of design changes.

Values set on the manual operation screen are saved as parameter settings.



- For more information about the needle bar setting screen, refer to "Chapter 2 3-3. Settings on needle bar setting screen".
- For more information about the manual operation screen, refer to "Chapter 2 3-4. Settings on manual operation screen".

3-3. Settings on needle bar setting screen

Make presser foot settings per step for the selected design. The set value will be stored in design data.

You can make the following presser foot settings on the needle bar setting screen: presser foot lower dead point, presser foot stroke, presser foot timing, and presser foot F.B. lower dead point.

The following example shows how to set the height of the "presser foot lower dead point".



- This operation cannot be operated when the functional limit level is set to "2".

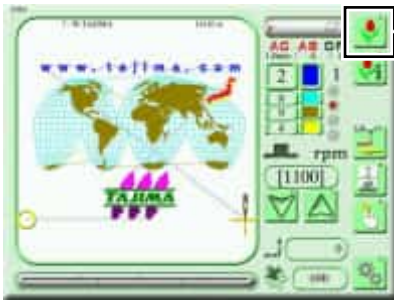

1 Press  on the main screen.

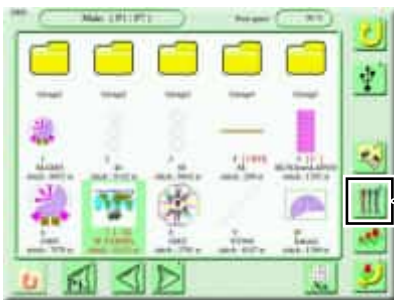

2 Press .

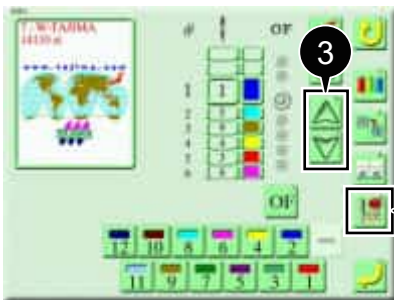

3 Press  to select the desired step.

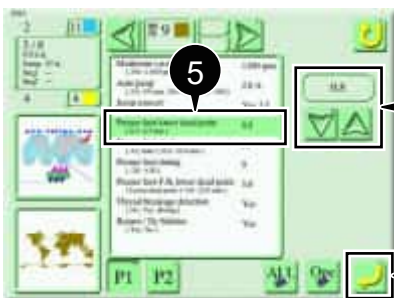

4 Press .

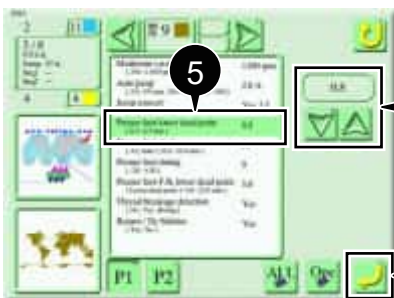

5 Select the "Presser foot lower dead point".

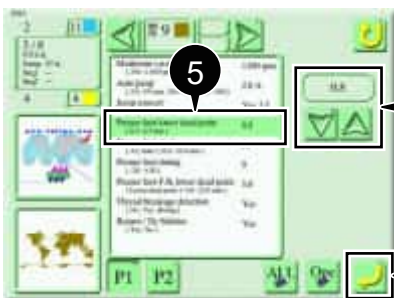

6 Press  to set the height of the lower dead point.

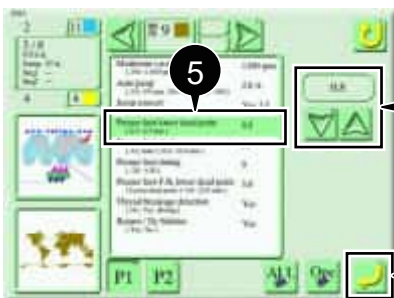

7 Press .

3-4. Settings on manual operation screen

Make presser foot settings for the entire machine "Any" or for the current needle bar step.

Values set manually are saved as the entire machine (parameter) or the per step settings of the design.

You can make the following presser foot settings on the manual operation screen: lower dead point, stroke mode, stroke, timing, and F.B. lower dead point.

The following example shows how to set the height of the "lower dead point" of the needle bar currently being used.



- This operation cannot be operated when the functional limit level is set to "2".

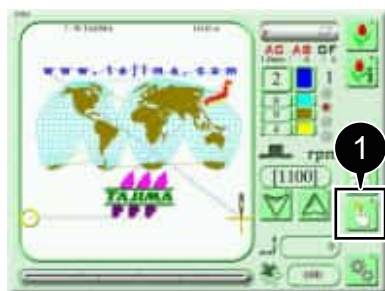

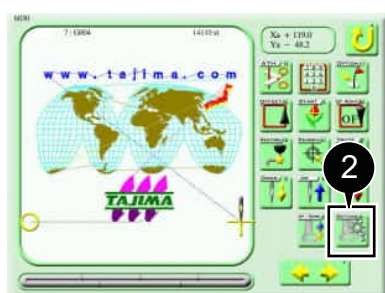

- 1 Press  on the main screen.

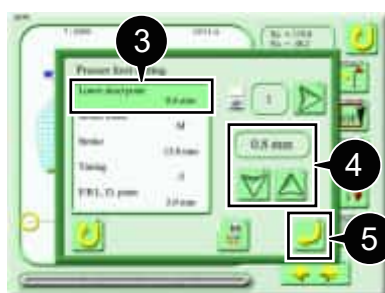

- 2 Press .



- 3 Select "Lower dead point".

- 4 Press   to set the height of the lower dead point.



- When making "Stroke" settings, first set the "Stroke Mode" to "M" (Manual).

- 5 Press .

4. Responding to Thread Breakage

4-1. How to respond to a thread breakage indicator

When a thread breakage is detected, the machine automatically stops and the multi-color LED (right side) on the head where the thread breakage occurred lights up or blinks in red. In addition, an error No.291 or 293 appears on the operation panel.

How to respond to a thread breakage differs depending on whether the LED lights up or blinks and the error No. displayed.

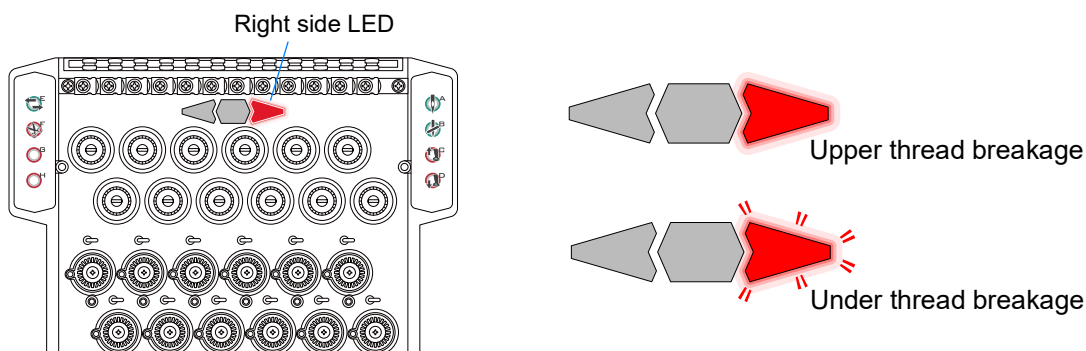

Display	Condition	Troubleshooting
Lit (Error No. 291)	Upper thread breakage	Pass the broken upper thread through the needle.
Blinking (Error No. 293)	Under thread breakage	Remove the bobbin from the rotary hook and check the condition of the under thread. If the under thread is lost or its remaining part is short, replace the bobbin with new one.

- Once you pass the upper thread or replace the under thread and resume embroidery, the message screen disappears.

4-2. Repair stitches

During the period between when a thread breakage occurs and when the machine stops, the frame advances without the thread by several stitches and thus a part of embroidery goes missing. To resume embroidery after a thread breakage, move back the frame from the position where it was stopped and resume embroidery at such a position that the seams overlap a little for better finishing.

■ An overview of repair stitches

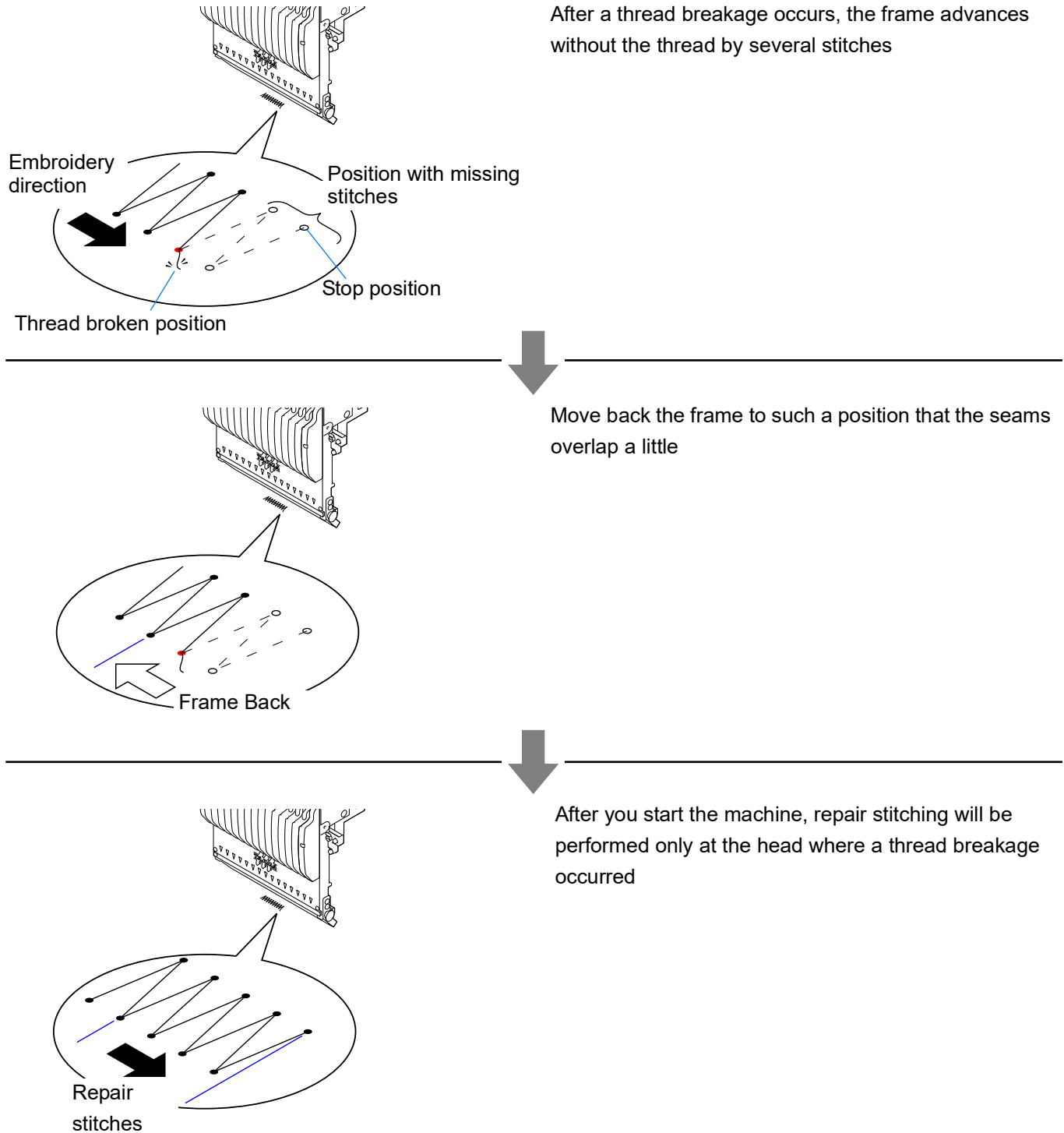

- If the "Auto F.B. after T. Detection" parameter is set to "Yes", the frame automatically moves back after a thread breakage. For details, refer to the separate "Parameter Settings" manual.

How to operate

This section describes return stitching and repair stitching methods for the thread-broken head after the frame-back operation.



- For more information on return stitching, refer to "Chapter 1 4. Direct Command Switch".

CAUTION

- ⊘ Do not place your hands on the needle or the table when you operate the machine. The needle bar or frame moves and may cause injury to your fingers and hand.

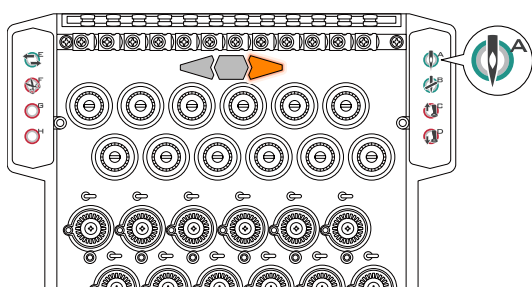
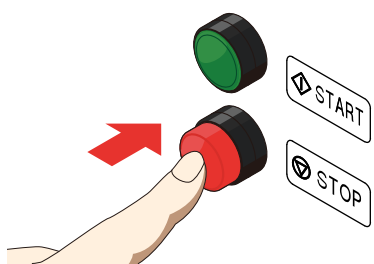

- 1 Keep pressing the stop switch to move back the frame to such a position that the seams overlap a little.



- For more information on moving back the frame (Frame Back), refer to "Chapter 3 1. Moving Back or Moving Forward the Frame along the Stitches".

- 2 Press  once on the tension base of the head where a thread breakage occurred. The multi-color LED (right side) changes in color from red to orange.

- 3 Press the start switch. The machine starts up and performs return stitching and repair stitching.

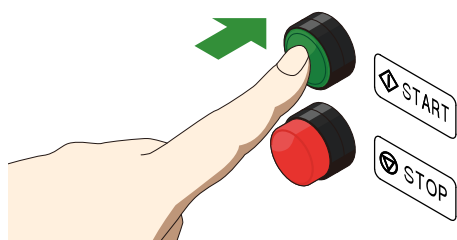

Chapter 3

Manual Operation

1. Moving Back or Moving Forward the Frame along the Stitches

You can move back (Frame Back) or forward (Frame Forward) the frame along the stitches with the needle bar stopped.

This feature is useful when you want to:

- Resume embroidery from a stitch before the position where a thread breakage occurred for the purpose of performing repair stitching after a thread breakage
- Resume embroidery from within the design or from an intermediate step
- Skip an area within the design or an intermediate step

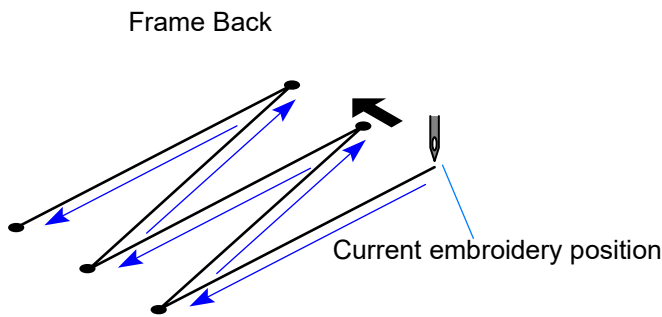

The frame will be moved to the direction where stitches return with the needle bar stopped.

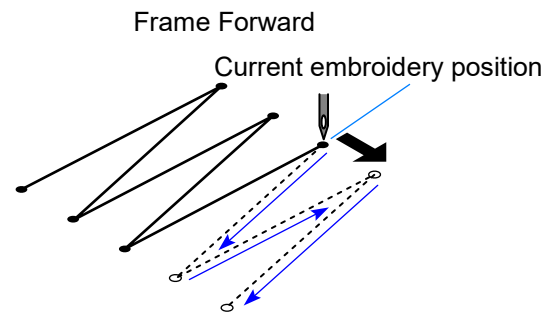

The frame will be moved to the direction where stitches advance with the needle bar stopped.

You can use the Frame Back and Frame Forward features in one of the following three ways:

Method	Unit	Detail
Stop switch	Stitch	Move back/forward the frame on a stitch by stitch basis along the stitches.
Operation panel		Move back/forward the frame across the stitch count you specify.
Operation panel	Color change	Move back/forward the frame by the number of color change codes you specify.

1-1. Frame Back/Forward by 1-stitch unit

You can use the stop switch to move back or forward the frame on a stitch by stitch basis.

CAUTION

 Do not put your hand on the table when you operate the machine. The frame moves and may cause injury to your fingers and hand.

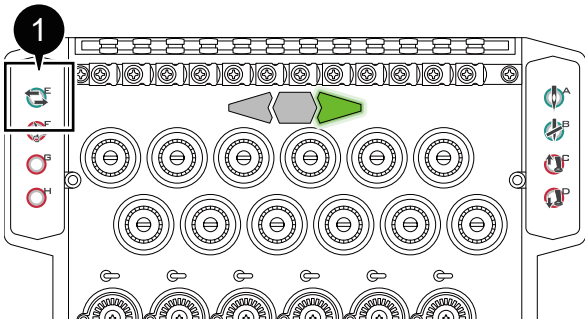

- 1 Press  on the tension base to switch between Frame Back and Frame Forward.



- The multi-color LED lighting color changes every time you press the switch. Flashes in white for two seconds when the setting is changed.



: Frame Back (left side lights up)

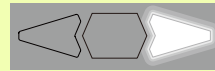

: Frame Forward (right side lights up)

- 2 Press the stop switch and hold it in that position. The frame moves on a stitch by stitch basis along the stitches.
- 3 Release the stop switch when the frame moves to the desired frame position (within 10 stitches). The frame stops moving.

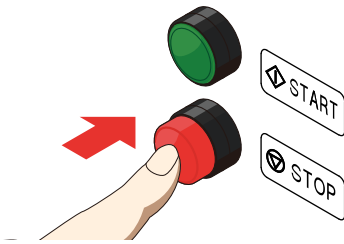

■ High-speed travel of Frame Back/Frame Forward

Pressing the stop switch for at least 11 stitches will switch the machine to high-speed travel (feed unit). To stop high speed travel, release the switch once and press the stop switch.

In this mode, you can configure the frame feed amount for high-speed travel. For details, refer to the separate "Parameter Settings" manual.

[Frame Back]

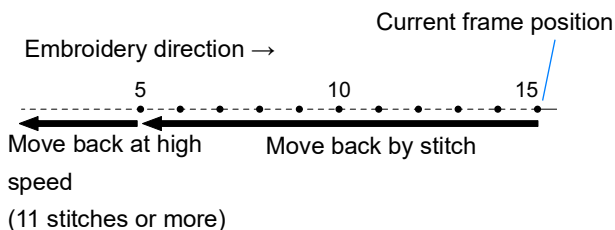

[Frame Forward]

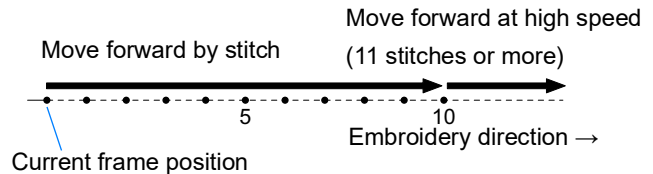



1-2. Frame Back/Forward by specifying the number of stitches

You can move back or forward the frame by the number of stitches you specify.

CAUTION

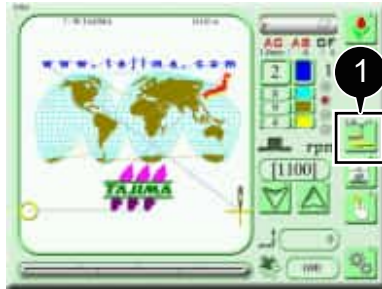
 Do not put your hand on the table when you operate the machine. The frame moves and may cause injury to your fingers and hand.



1 Press  on the main screen.

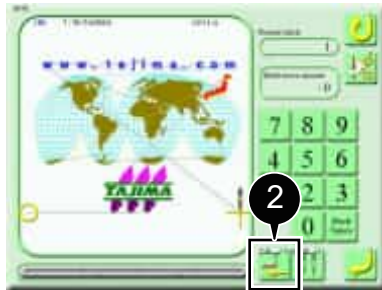

2 Select the direction in which to feed the frame.



: Frame Back



: Frame Forward



3 Input the number of stitches (for example, 500).



4 Press .

The frame moves along the stitches by the specified number of stitches.

1-3. Frame Back/Forward by specifying the number of color change

You can move back or forward the frame by the number of color changes you specify.

CAUTION

 Do not put your hand on the table when you operate the machine. The frame moves and may cause injury to your fingers and hand.

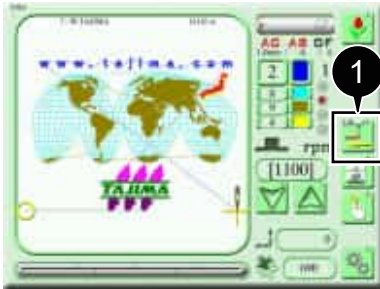

1 Press  on the main screen.

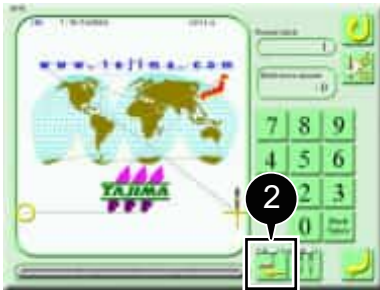

2 Select the direction in which to feed the frame.



: Frame Back



: Frame Forward

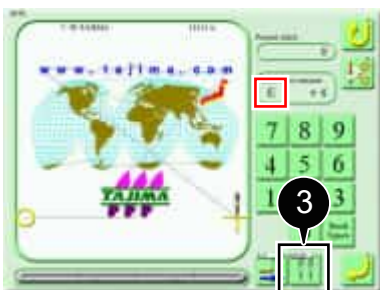

3 Press  as many times as the desired number of color changes.



- If there is no next color change code any more and it is the last color change code, "E" is displayed instead of "C" (red frame).

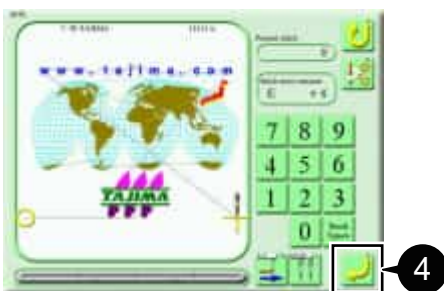

4 Press .

The frame moves along the stitches by the specified number of color changes.

2. Thread Trimming

2-1. ATH

You can trim both the upper and under threads or only the under thread.



- You can also perform thread trimming by holding down the F switch on the tension base. For details, refer to "Chapter 1 4. Direct Command Switch".

CAUTION

- Do not place your hands on the needle or the table when you operate the machine. The needle bar or frame moves and may cause injury to your fingers and hand.

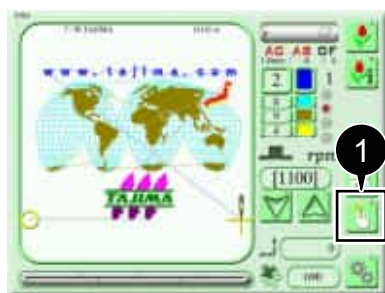

- 1 Press on the main screen.

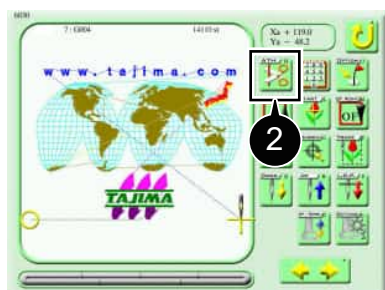

- 2 Press .



- 3 Execute thread trimming.



: Under thread only



: Upper thread and under thread

3. Needle Bar Related Operations

3-1. Color change

A color change is performed by sliding the needle bar case and switching the needle bar at the sewing needle to a different needle bar.



- If the thread is connected to the fabric, trim the thread before the color change.
- If you manually switch the needle bar and want to use the new one for embroidery, set the "Auto Color Change (AC)" parameter to "NO".

For details, refer to the separate "Parameter Settings" manual.

CAUTION

-  Do not place your hands on the needle or the table when you operate the machine. The needle bar case slides and may cause injury to your fingers and hand.

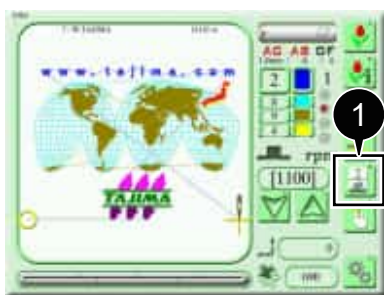

- 1 Press  on the main screen.

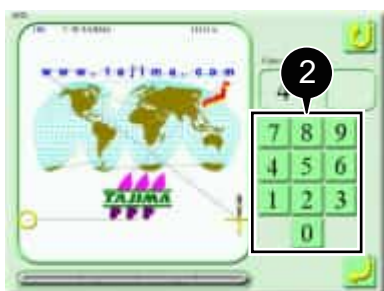

- 2 Select the new needle bar No. (for example, needle bar No. 8).

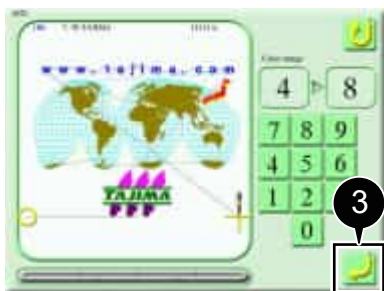

- 3 Press .
- The needle bar case slides and the needle bar switches to the new one.

3-2. Raising or lowering the needle bar

You can lower or raise the selected needle bar.

CAUTION

 Do not place your hands on the needle or the table when you operate the machine. The needle bar moves up and down and may cause injury to your fingers and hand.

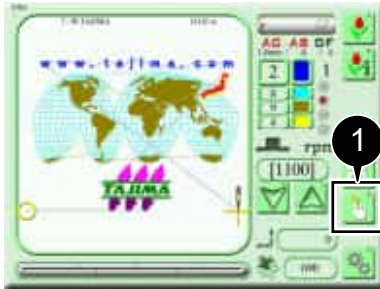

1 Press  on the main screen.

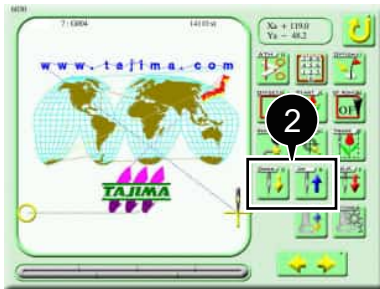

2 Raise or lower the needle bar.



: Lower the needle bar.



: Raise the needle bar.

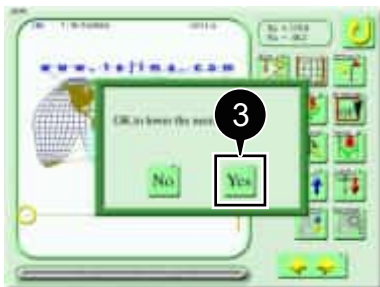

3 Press .

The needle bar is lowered or raised.

3-3. Stopping the needle bar at the lower dead point

You can lower the selected needle bar to the lower dead point.

- Since the needle bar lowers to the lower dead point, the needle remains penetrating the fabric. This feature is useful when you change the fabric to embroider consecutively on the long fabric.

CAUTION

 Do not place your hands on the needle or the table when you operate the machine. The needle bar moves down and may cause injury to your fingers and hand.

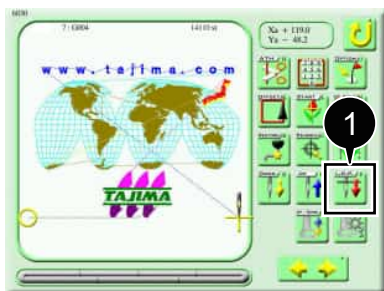

1 Press  on the manual operation screen.

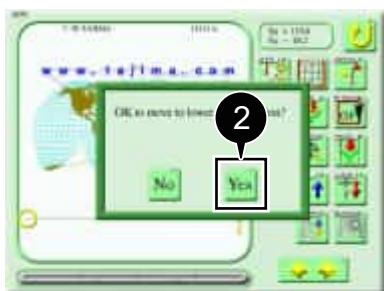

2 Press  .
The needle bar lowers to the lower dead point.

3-4. Raising or lowering the presser foot

You can lower or raise the selected needle bar presser foot.

CAUTION

Do not place your hands on the needle when you operate the machine. The presser foot moves up and down and may cause injury to your fingers and hand.

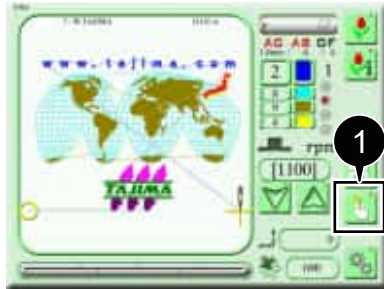

1 Press  on the main screen.

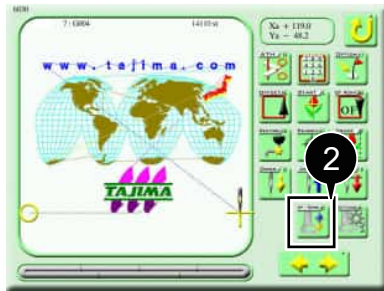

2 Press .



3 Raise or lower the presser foot.



: Retracting position



: Frame back position



: Presser foot lower dead point

4. Various Frame Movement Operations

4-1. Moving the frame to the preset optional position

You can move the frame to a preset optional position.



- For more information on presetting a frame position, refer to the separate "Parameter Settings" manual.

CAUTION

- Do not put your hand on the table when you operate the machine. The frame moves and may cause injury to your fingers and hand.

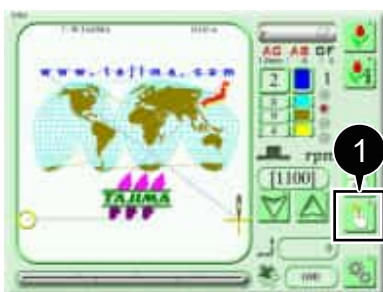

1 Press on the main screen.

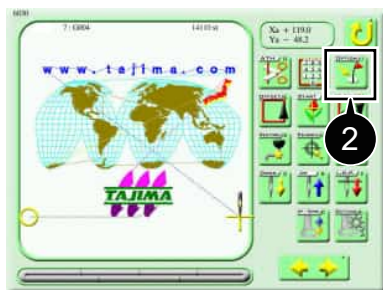

2 Press .

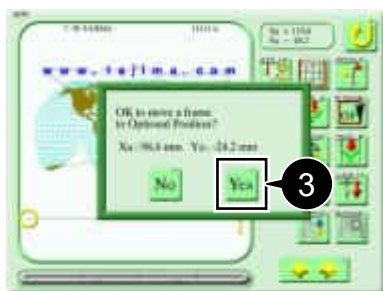

3 Press .
The frame moves to the preset optional position.

4-2. Moving the frame to the original position (manual offset)

You can move the frame to the original position after you have moved it manually during embroidery.

CAUTION

 Do not put your hand on the table when you operate the machine. The frame moves and may cause injury to your fingers and hand.

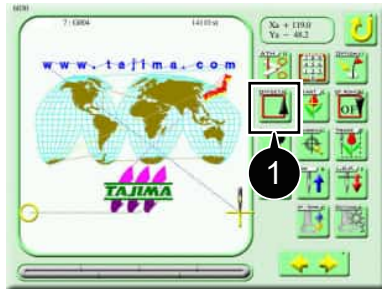

1 Press  on the manual operation screen.

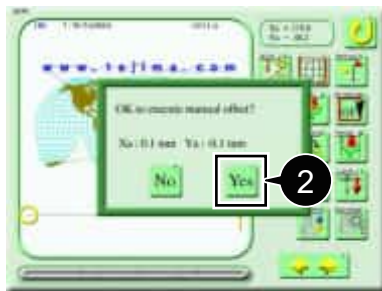

2 Press .
The frame moves to the original position.

4-3. Moving the frame to the start position

You can move the frame to the design start position.

CAUTION

 Do not put your hand on the table when you operate the machine. The frame moves and may cause injury to your fingers and hand.

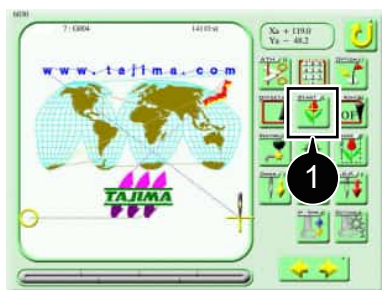

1 Press  on the manual operation screen.

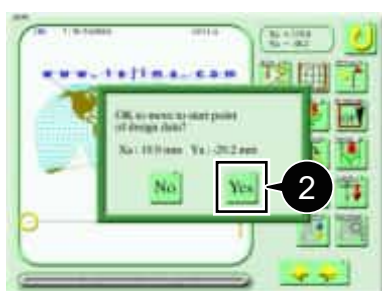

2 Press .
The frame moves to the start position.

4-4. Moving the frame to the offset position

You can move the frame to the offset position.

The offset position is a position where the frame is automatically moved (offset toward you).

The frame stops at the desired position to exchange with frames or prepare with a appliques.



- To move the frame to the offset position, you must preset it. For details, refer to "Chapter 6 1. Moving the Offset Frame".

CAUTION

-  Do not put your hand on the table when you operate the machine. The frame moves and may cause injury to your fingers and hand.

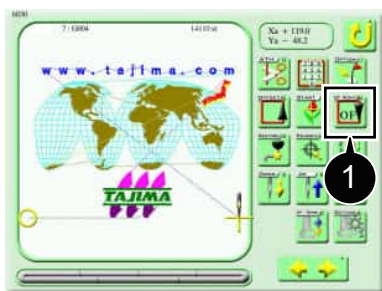

- 1 Press  on the manual operation screen.

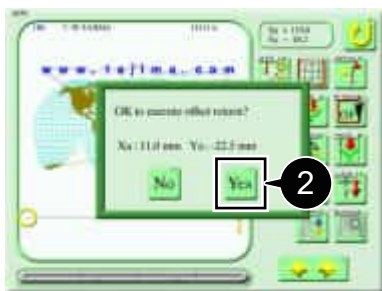

- 2 Press .
The frame moves to the offset position.

4-5. Moving the frame by entering a numeric value

You can move the frame by entering a numeric value.



- The value you enter is the amount of travel from the current frame position.

CAUTION



Do not put your hand on the table when you operate the machine. The frame moves and may cause injury to your fingers and hand.

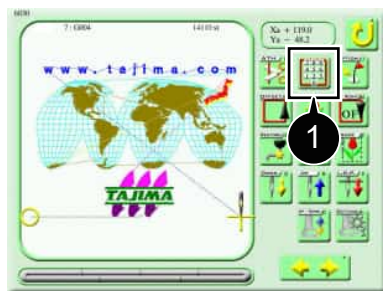

1 Press on the manual operation screen.



- Pressing the coordinate icon will change the indication.
- Current frame position

$Xa + 19.2$
 $Ya + 98.7$: Based on absolute origin

$Xr + 0.0$
 $Yr + 0.0$: Based on the start position

- Frame Travel amount from current frame position

$Xm - 20.0$
 $Ym + 15.0$: Travel amount you enter

$Xm -$ (minus sign): Frame moves to right

$+$ (plus sign): Frame moves to left

$Ym -$ (minus sign): Frame moves to rear

$+$ (plus sign): Frame moves to front

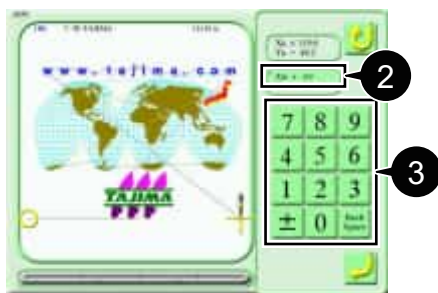

2 Press $Xm + 0.0$.

3 Enter the X-axial travel amount (for example, +60.0).

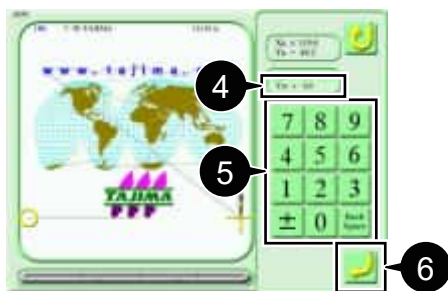

4 Press $Ym + 0.0$.

5 Enter the Y-axial travel amount (for example, -85.0).

6 Press .

The frame moves to the specified position.

4-6. Absolute origin search

Be sure to execute absolute origin search after you have moved the frame by hand with the power OFF.



The absolute origin of the frame is a reference point ($X_a = 0.0$, $Y_a = 0.0$) to calculate the current frame position.

If the absolute origin is not correctly registered, the following problems may occur:

- The frame coordinates are not displayed correctly.
- After emergency stop or power failure, turning ON the power fails to return the frame to the position where the operation was suspended.

CAUTION

-  Do not put your hand on the table when you operate the machine. The frame moves and may cause injury to your fingers and hand.

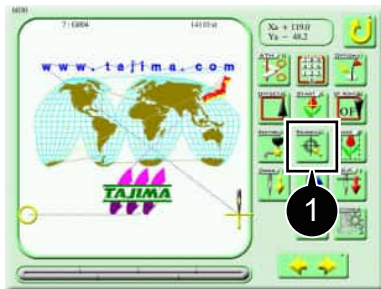

- 1 Press  on the manual operation screen.

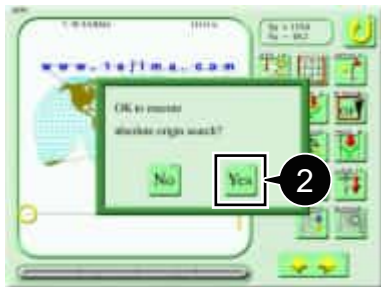

- 2 Press .

The frame will move to the absolute origin and return to the original position.

4-7. Power Resume

You can return the frame to the same position as just before the power turned off after unexpected power failure during embroidery or emergency stop.



- If you moved the frame by hand with the power OFF during embroidery and now want to return it to the original position, turn ON the power and manually perform power resume.

This feature requires that the absolute origin of the frame is correctly registered.

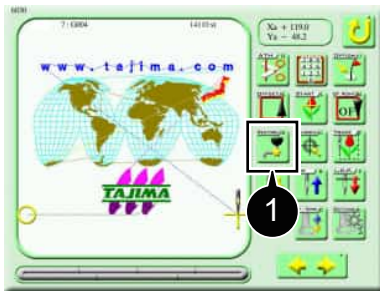

- 1 Press  on the manual operation screen.



- 2 Select the power resume method.



: Perform power resume after trimming the thread.



: Perform power resume without trimming the thread.



- When you perform power resume, the machine checks the absolute origin and the frame moves to a position several stitches back from the position where it was when the power was turned OFF.

5. Other Operation

5-1. Turning ON/OFF the LED lamp

You can turn ON/OFF the LED lamp.

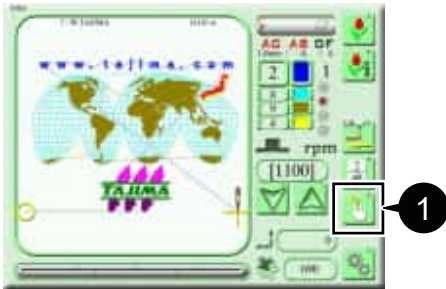

1 Press  on the main screen.

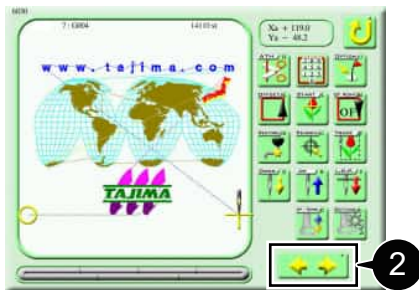

2 Press .



3 Turn ON/OFF the LED lamp set.

 : Turn OFF

 : Turn ON

5-2. Automatic lubrication system

You can operate the automatic lubrication system.

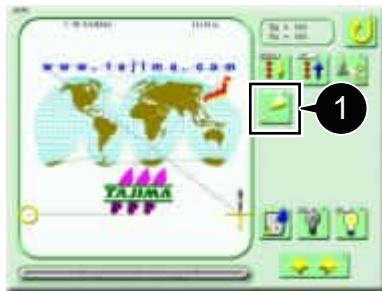

- 1 Press  on the manual operation screen.

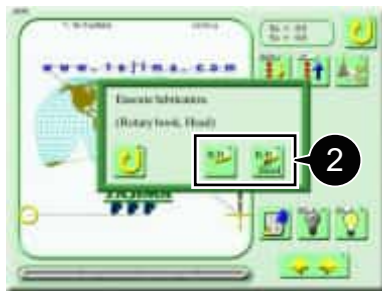

- 2 Lubricate the rotary hook or the rotary hook and head.



: Rotary hook



: Rotary hook and head

5-3. Moving up or down optional device

Moves up or down optional devices (ESQ-C and seed beads devices).



- This is not available unless you select a needle bar equipped with an optional device.

CAUTION

-  Keep away from the device when you operate the machine. The machine moves and your face or hand may be injured.

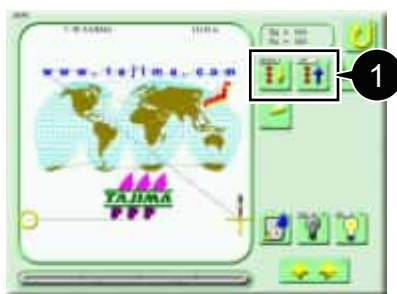

- 1 Press the function.



: Moves down optional device.



: Moves up optional device.

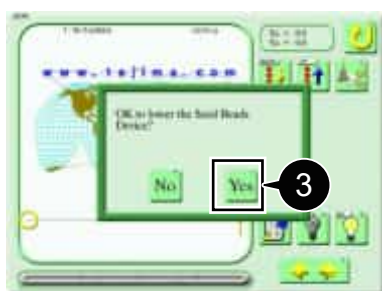

- 2 Press .

The operation is executed.

Chapter 4

Design Management

1. Design Input/Output

Use the following steps to input designs from the outside to the machine memory or save designs in this machine memory to USB memory.

1-1. From the USB memory to the machine memory

Designs can be saved from the USB memory to the machine memory.



- For details, refer to "Chapter 2 2-1. Saving or storing designs into the machine memory".

1-2. From the machine memory to the USB memory

The following example shows how to select two designs and store them as "T3" data in the USB memory.



- This feature is only available if the functional limit level is set to "SEL".

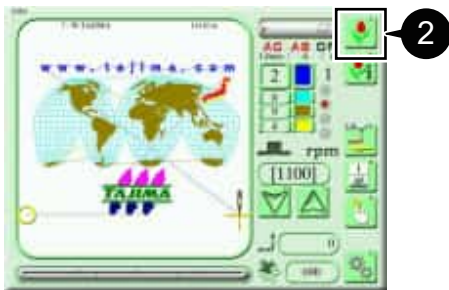

1 Insert a USB memory into the USB port on the operation panel.



2 Press  on the main screen.



3 Select the first design you want to save.

4 Press .



- All designs are selected when  pressed.
- All designs are deselected when  pressed.

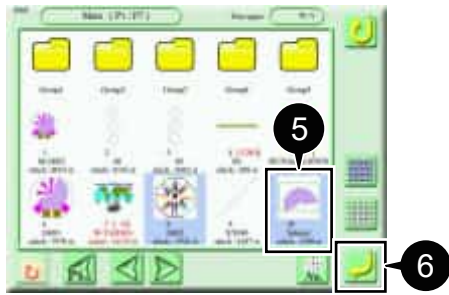

5 Select the second design.



•  : Select all designs.

•  : All clear



6 Press .

7 Press .



• If you want to save the design without changing the file name, skip to step 9.



8 Change the file name of the first design.
(For example, change to "G0009".)



• Enter up to 20 alphanumeric characters. The file name you enter will be displayed on your PC ("G0009.TCF" in this example).

9 Press .

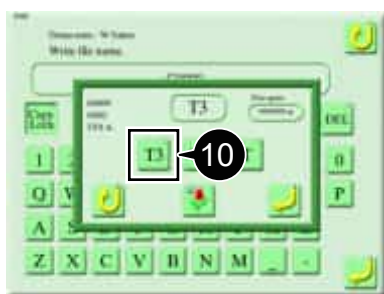

10 Press .



• Usually, select . For more information on the file format, refer to "Chapter 4 ■ About the design display on your PC".

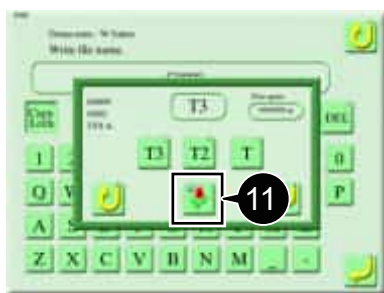

11 Select the file format.



: Save in different formats for each design.



: Save the selected designs in the same file format.

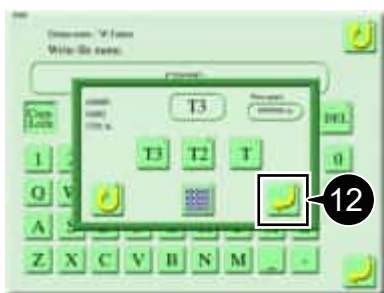

12 Press .



• If you want to save the design without changing the file name, skip to step 14.



13 Change the file name of the second design you want to save.
(For example, change to "G0009".)

14 Press .

The designs are saved in the USB memory.

■ About the design display on your PC

When you read the designs saved in the USB memory (for example, file name "G0003") into your PC, they are displayed as follows:

Saving format	Display on your PC	Use
T3 (TCF) ^{*1}	G0003.TCF	Data integrating T2 (CT0, DGF, TBF) and CT1 The following conditions are included in CT1. Message S Message E
T2 (TBF) ^{*2}	G0003.CT0	Condition data (color change sequence, start position)
	G0003.DGF	Thumbnail data
	G0003.TBF	Stitch data of TAJIMA binary format
T (DST)	G0003.DST	Stitch data of TAJIMA ternary format

*1 The T3 format consists of the following four sets of data combined into a single file:

TBF (TAJIMA binary format)	CT0 (Condition data)
DGF (Thumbnail data)	CT1 (Message)

*2 The T2 format consists of the following three sets of data, but not in a single file:

TBF (TAJIMA binary format)	CT0 (Condition data)
DGF (Thumbnail data)	

1-3. How to connect to Your PC



- This operation requires you to install DG by Pulse (embroidery digitizing software) on your PC. For more information, refer to the user's manual for DG by Pulse.

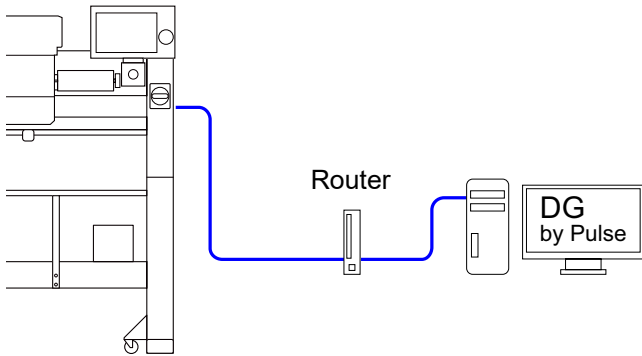

- 1 Turn OFF PC, router, and machine, and connect a LAN cable between PC and machine.



- To connect the machine via a router to PC, use a straight cable available on the market.

- 2 Turn ON the router.
- 3 Turn ON the PC and start "DG by Pulse".
- 4 Turn ON the machine.

- 5 Press  on the main screen.



- To use this feature, enter the password to set the functional limit level to "SEL".

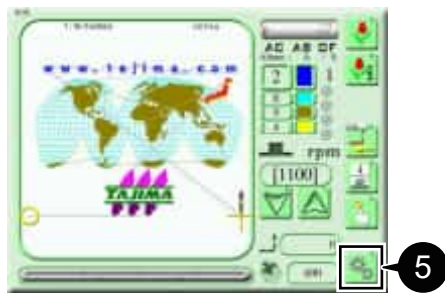

- 6 Press .

- 7 Select "78. Optional device (software)".

- 8 Press .



- 9 Select "1. Network".

- 10 Press .





11 Select "Network" and select "DG/ML[V1]" by pressing



12 Select "Auto". Select "Auto" by pressing



13 Press



Various addresses are automatically acquired.



- If automatic acquisition fails, check the LAN cable connection, operating steps, and the settings of DG by Pulse.



14 Press



The machine and PC will be connected.

1-4. From a PC to the machine memory

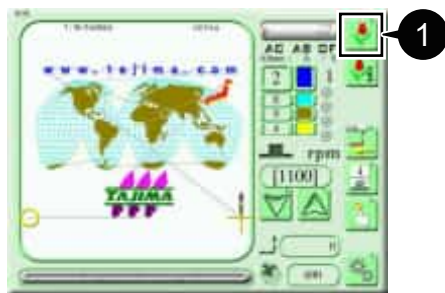

The following example shows how to specify designs saved on the PC and save them into the machine "Main" memory.

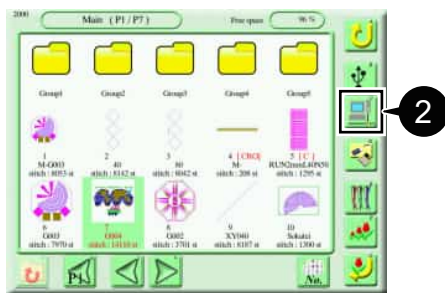

1 Press  on the main screen.



2 Press .
Designs stored in the specified folder on the PC are displayed.

 • If an icon  is displayed, it means that DG by Pulse is not connected to your PC. For more information on connecting the machine to your PC, refer to "Chapter 4 1-3. How to connect to Your PC".



3 Select a design.

4 Press .



5 Press  "Main".

The process of saving the design completes.

1-5. From a PC to the machine memory (bar code reader)

Once you read a barcode with a barcode reader, the design is saved in the machine memory and the data is automatically set.

If you read multiple barcodes, the last design data is set.

- You can create barcodes using the print function of DG by Pulse. For more information, refer to the user's manual for DG by Pulse. Use a USB-connectable barcode reader available on the market.

Barcode reader

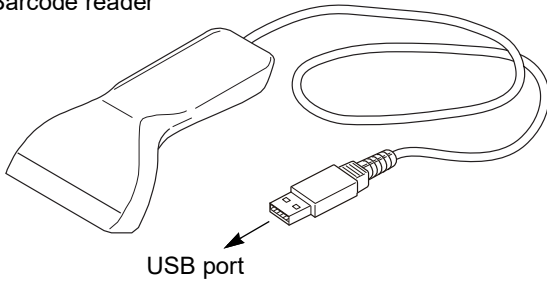

- 1 Connect a bar code reader with the operation panel via its USB interface.

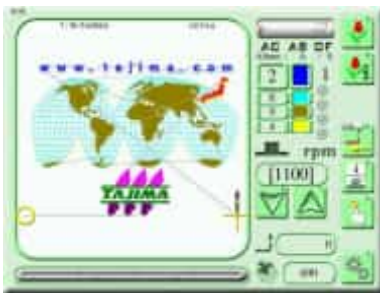

- 2 Display the main screen.



- You can read barcodes also from the following screen numbers:
No. 2000, No. 4100, No. 4150

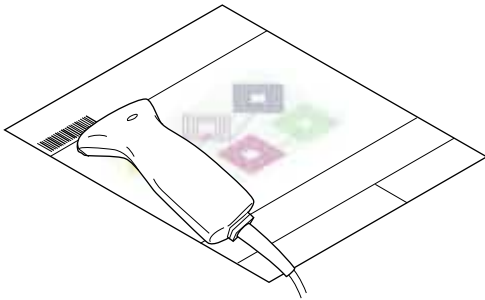

- 3 Read the barcode by using the barcode reader.
The design data is set.



- If you repeatedly read the same barcode, as many times as you read will be stored in the machine memory.

■ If you read a barcode during embroidery

During embroidery, you can pre-read the next embroidery design using the barcode reader.

- You can pre-read only one design.
- If you read multiple barcodes during operation, the last design you read will be selected.
- When suspending to embroider a design during operation and setting the data of another design, the pre-read design will be deleted.
- When suspending to embroider some design during operation and to perform the data setting of the pre-read design, read the barcode again.

2. Deleting Designs

This section describes how to delete designs in the machine memory.

2-1. Deleting single design in the machine memory

To delete one design at a time, use the following steps.

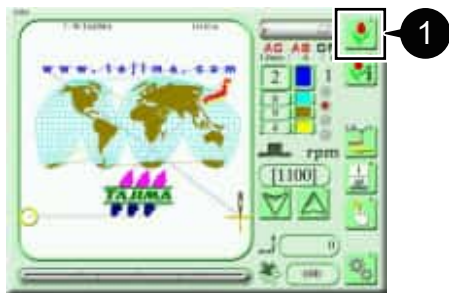

1 Press  on the main screen.

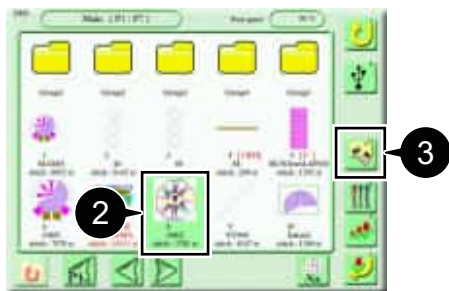

2 Select the design you want to delete.

3 Press .



-  : Select all designs.

-  : All clear

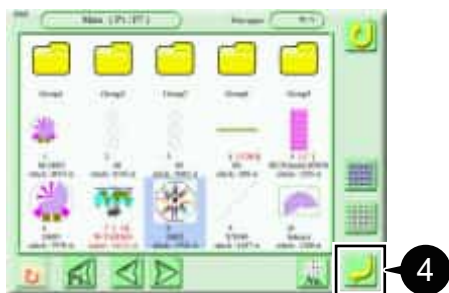

4 Press .



5 Press .



6 Press .

The operation is executed.



- If you delete the design whose data is set, you cannot continue embroidery.

2-2. Deleting plural designs in the machine memory (plural designs at once)

To delete plural designs at once, use the following steps.

The following example shows how to delete two selected designs at once.



- If the designs you want to delete belong to different layers, delete them for each layer.

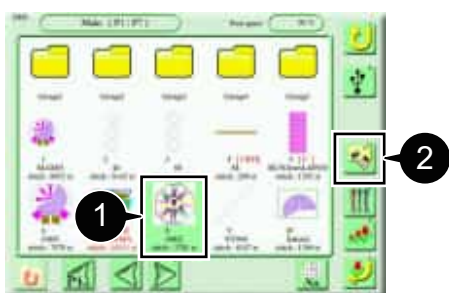

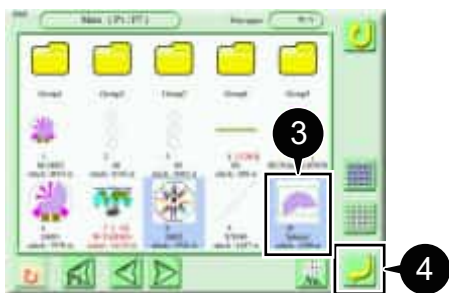

1 On the design selection screen, select the first design you want to delete.

2 Press .



3 Select the second design you want to delete.



-  : Select all designs.
-  : All clear

4 Press .

5 Press .





6 Press .

The operation is executed.



- If you delete the design whose data is set, you cannot continue embroidery.

2-3. Deleting designs in the USB memory

The following example shows how to delete two selected designs.



- If the designs you want to delete belong to different layers, delete them for each layer.

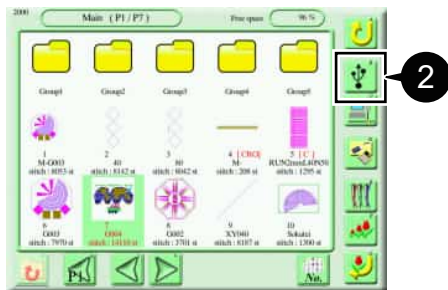

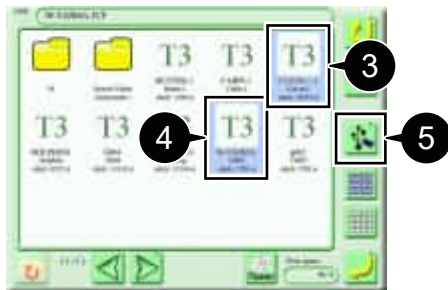

1 Insert a USB memory containing designs into the USB port on the operation panel.

2 Press .



3 Select the first design you want to delete.



-  : Select all designs.
-  : All clear

4 Select the second design you want to delete.

5 Press .

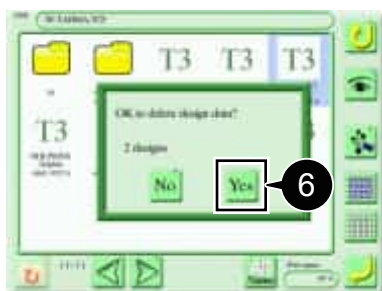

6 Press .

The deletion is performed.

3. Changing the Design Name and Storage Location

This section describes how to change design names and storage locations in the machine memory.

3-1. Renaming a design name

To rename a design saved in the machine memory one by one, use the following steps.

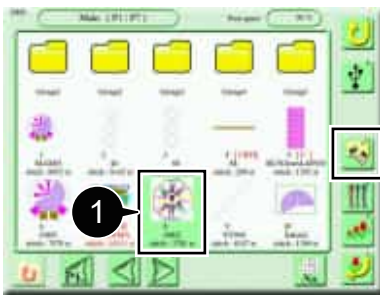

1 Select the target you want to rename on the design selection screen.

2 Press .

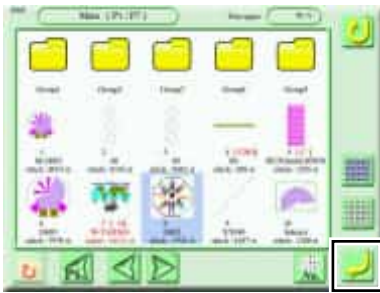

3 Press .



4 Press .



5 Enter the new design name.



• You can enter a design name up to 8 characters long.

6 Press .

The design is renamed.

3-2. Changing the design storage location

To move designs to a different storage location in the machine memory, use the following steps. The following example shows how to select two designs and move them to the "Group2" folder.

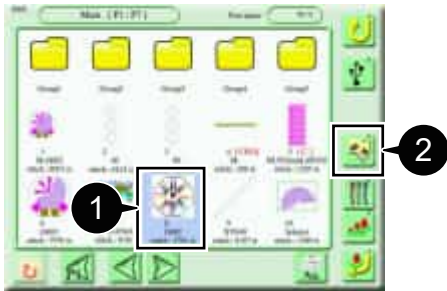

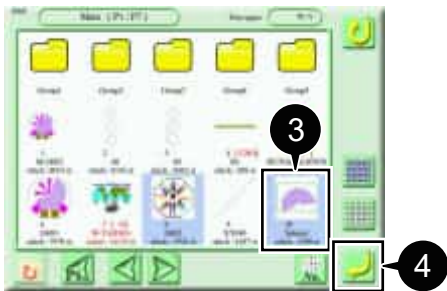

1 On the design selection screen, select the target design you want to move.

2 Press .



3 Select the second target design.



-  : Select all designs.
-  : All clear

4 Press .



5 Press .



6 Press  "Group2".

The designs are saved in the "Group2" folder.

Chapter 5

Editing Needle Bar Steps and Designs

1. Editing Needle Bar Steps

You can change embroidery conditions (such as the needle bar No. and RPM) for each needle bar step you specify.



- This operation cannot be operated when the functional limit level is set to "2".
- For items overlapping with the setting value of a machine parameter, the value here will take priority.

1-1. Setting needle bar step embroidery conditions

The following example shows how to change the embroidery conditions for needle bar step 5 by changing the needle bar No. 1 to No. 9 and changing the Maximum RPM from 1,200 rpm to 700 rpm.

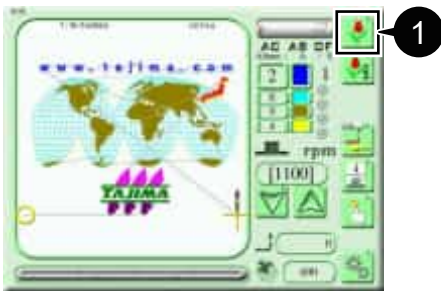

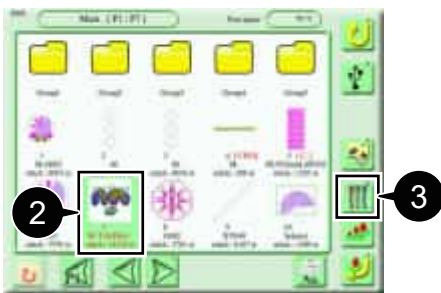

1 Press  on the main screen.

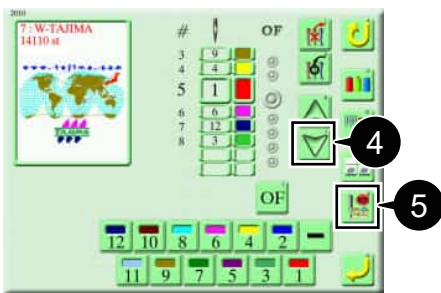

2 Select your desired design.

3 Press .



4 Press  to select needle bar step 5.

5 Press .

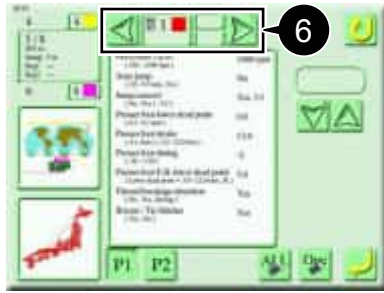

6 Press  to select needle bar No. 9.



7 Select "Maximum RPM".



8 Press  to select "700 rpm".



9 Press .

The embroidery conditions are changed.

10 Press .

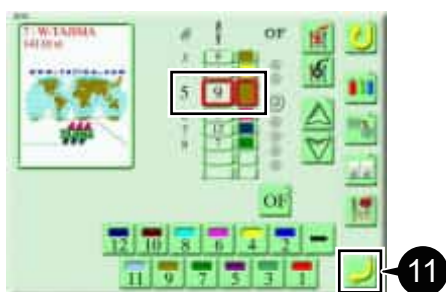

11 Press .

The needle bar step whose embroidery conditions have been changed is highlighted in a red frame.

1
2
3
4
5
6
7
8
9

■ Detail of the settings screen

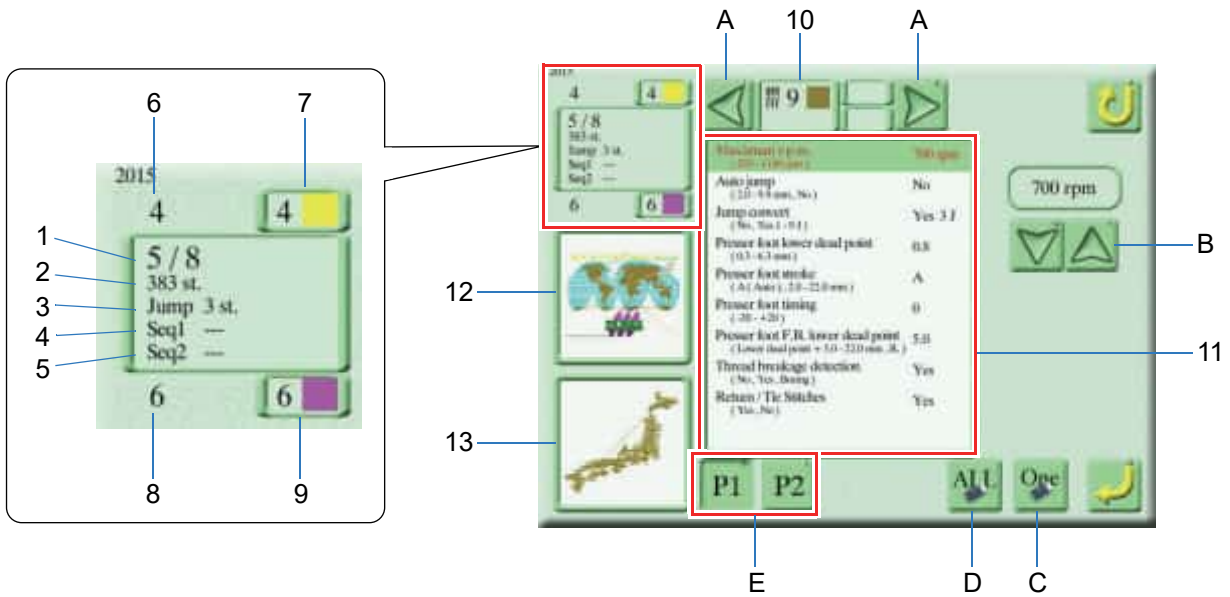

No.	Description	No.	Description
1	Currently selected step / Total number of steps in the design	10	Display of the needle bar No. and thread color for the currently selected step
2	Number of stitches in the step	11	Display of embroidery conditions (changed items are highlighted in red)
3	Number of jump codes in the step	12	Display of entire design
4	Number of sequin output 1 in the step	13	Enlarged view of the portions embroidered for the currently selected step
5	Number of sequin output 2 in the step	A	Change the needle bar No.
6	Previous step	B	Change the value
7	Display of the needle bar No. and thread color for the previous step	C	Initialize the selected step items
8	Next step	D	Initialize all the selected step items
9	Display of the needle bar No. and thread color for the next step	E	Switch the screens (between P1 and P2)

■ Embroidery condition items

P1

Embroidery conditions	Setting range
Maximum RPM	250 rpm to Maximum rpm of machine
Auto jump	2.0 to 9.9 mm, No A, B: 240-360
Jump convert	No, Yes1 to 9J
Presser foot lower dead point	0.3 to 6.3
Presser foot stroke	A, 2.0 to 22.0
Presser foot timing	-20 to +20
Presser foot F.B. lower dead point	Lower dead point +5.0 to 22.0
Thread Breakage Detection	No, Yes
Return / Tie Stitches	Yes, No

P2

Embroidery conditions	Setting range
Sequin output 1	No, Sq1, sq2
Sequin output 2	No, Sq1, sq2
Satin stitch (area) ^{*1}	Whole, part, No
Satin stitch (Density) ^{*1}	0.4 to 1.0 mm
Satin stitch (Expansion) ^{*1}	-1.0 to +1.0 mm
FS mode	Yes, No

*1 Displayed only when the functional limit level is "SEL."

1-2. Insertion of needle bar step

A new needle bar step is inserted after the specified needle bar step.

All the needle bar steps will follow the inserted one.

The following example shows how to insert a new needle bar step after the needle bar step 4.



1 Select your desired design on the design selection screen.

2 Press .

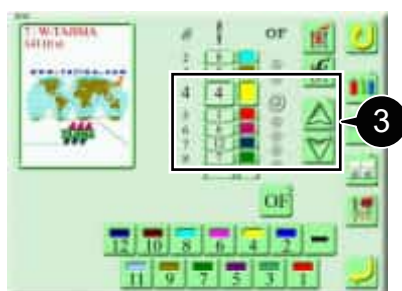

3 Press  to select needle bar step 4.

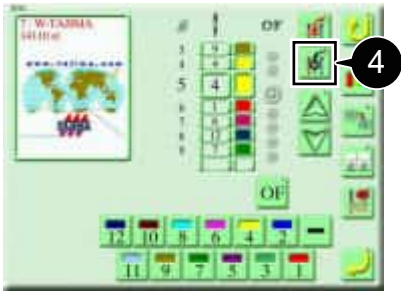

4 Press .

5 Press .

A new needle bar step is inserted.



- The inserted needle bar step is given the same needle bar No. as the one that precedes it. Change the needle bar No. as needed.
- The last needle bar step is not embroidered.

1-3. Deletion of needle bar step

You can delete your specified needle bar step.

All the needle bar steps after the deleted one will move up.

The following example shows how to delete the needle bar step 4.



1 Select your desired design on the design selection screen.

2 Press .

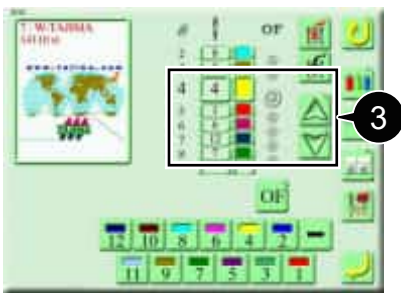

3 Press  to select needle bar step 4.

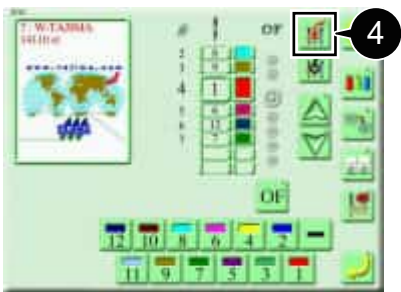

4 Press .

5 Press .

The needle bar step 4 is deleted.

1-4. Replacing the needle bar numbers at once

Follow the steps below to replace the needle bar steps of the same needle bar number with another one at once. Replacing a needle bar No. also changes the color of the design image on the operation panel.

The following example shows how to replace the instances of needle bar No. 8 in the needle bar steps with the needle bar No. 6 at once.

Before change			After change	
Needle bar step	Needle bar No.		Needle bar No.	
1	8	⇒	6	
2	5		5	
3	8	⇒	6	
4	5		5	
5	1		1	
6	8	⇒	6	

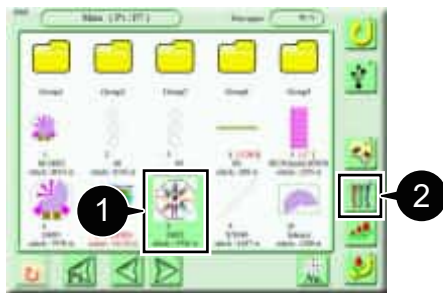

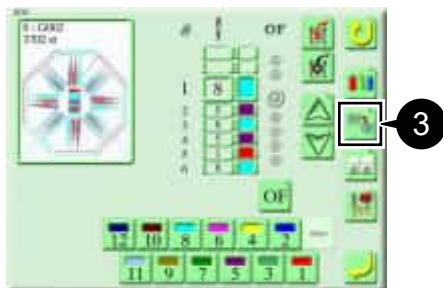

1 Select your desired design on the design selection screen.

2 Press .

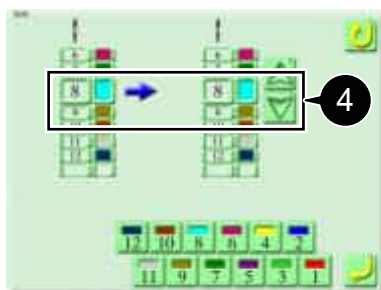

3 Press .



4 Press  to select needle bar No. 8.

1. Editing Needle Bar Steps

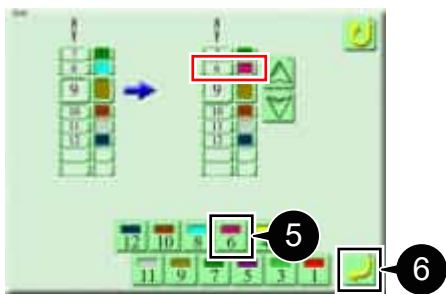

5 Press .

The needle bar No. 8 is changed to No. 6 (red frame).

6 Press .

All of the specified needle bar No. are replaced at once.

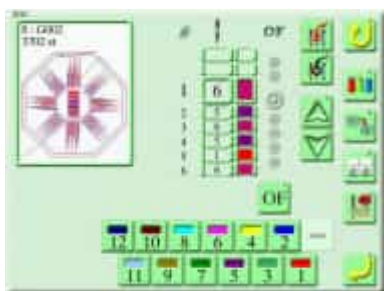

2. Needle Bar Management Function

2-1. Setting the needle bar thread color

You can change the thread color assigned to each needle bar.

Changing the thread color also changes the color of the design image displayed on the operation panel.

The following example shows how to change the needle bar numbers 1 and 5 to yellow and black, respectively.

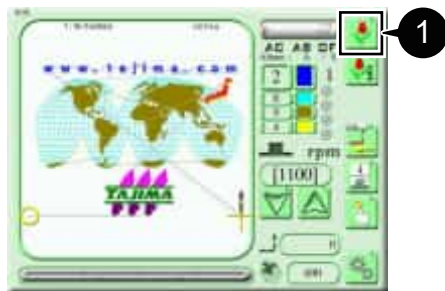

1 Press  on the main screen.



2 Select the design you want to change.

3 Press .

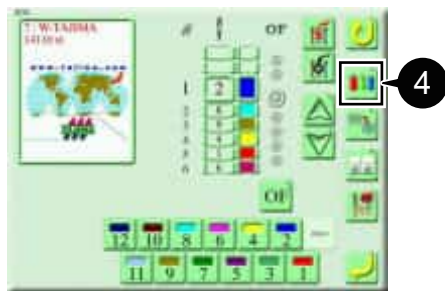

4 Press .



5 Press .

The needle bar No. 1 is selected.

6 Select yellow from the color palette.

The thread color of the needle bar changes to yellow.

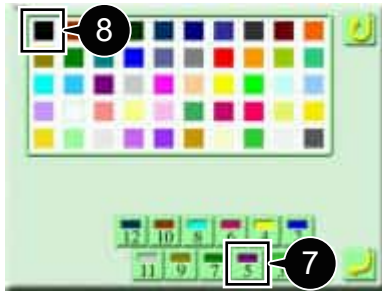

7 Press .

The needle bar No. 5 is selected.

8 Select black from the color palette.

The thread color of the needle bar changes to black.



9 Press .

The specified thread colors are set.

3. Editing a Design

3-1. Copying a design

Before you divide a design, you can copy the design in the machine memory so that the original design will be available. You can specify a folder in the "main" layer and each folder in the machine memory as the copying destination. You can copy as many designs as you like.

The following example shows how to select two designs and copy them into the "Group2" folder.

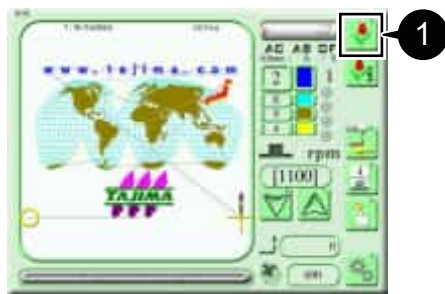

1 Press  on the main screen.

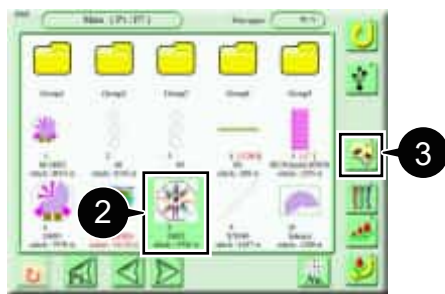

2 Select the 1st design you want to copy.

3 Press .

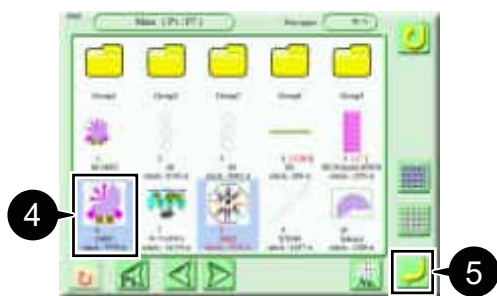

4 Select the 2nd design.



• All designs are selected when  pressed.

• All designs are deselected when  pressed.

5 Press .

The design is selected.



6 Press .



7 Press  "Group2".

The designs are copied in the "Group2" folder.

3-2. Division of design

You can divide a design before and after your specified stitch No. Note that the first divided design will include all the stitches prior to the specified stitch No.

The following example shows how to search for a design by Color Change function code and divide it before and after your specified stitch.



- This operation divides the original design. Copy the design in advance as needed.

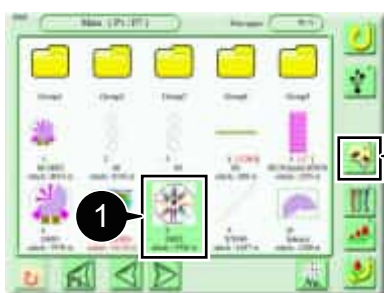

1 Select the design you want to divide on the design selection screen.

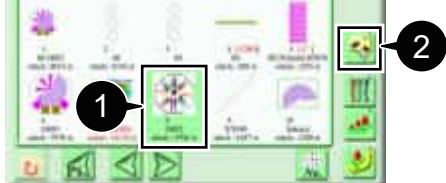

2 Press .

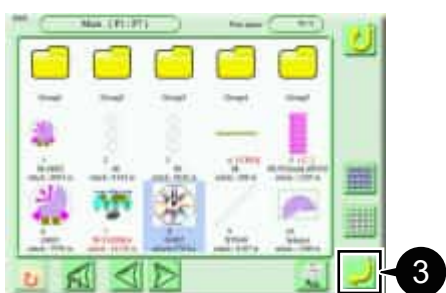

3 Press .
The design is selected.



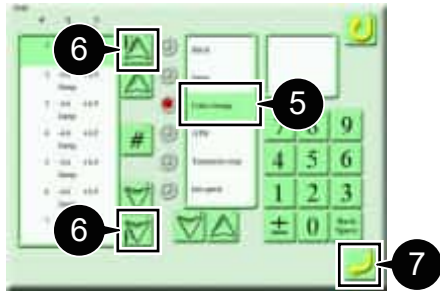

4 Press .



5 Select "Color change".

6 Start search.

 : Stitches before the selected stitch will be searched.

 : Stitches after the selected stitch will be searched.

Stitches that include the selected function code will be searched in order.



- For more information on searching for stitches, refer to "Chapter 5 6-2. Search by function code".

7 Press .

8 Press .

The design is divided.



- The following example shows how to divide the design No. 8 in the machine memory and save them in No. 8 and No. 155.

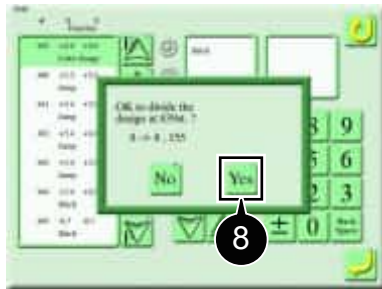

3-3. Combine of designs

You can combine multiple designs into a new design and save it in the same layer in the machine memory. The following example shows how to combine three designs.

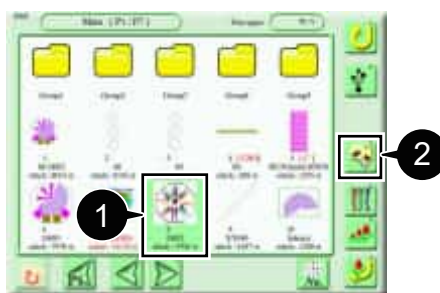

1 On the design selection screen, select the first design you want to combine.

2 Press .

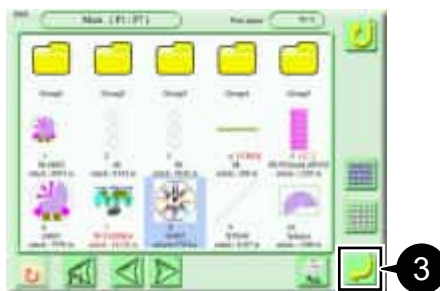

3 Press .

The 1st design is selected.

3. Editing a Design



4 Press 



5 Press 



6 Select the 2nd design.

7 Press 

The 2nd design is selected.



- To change the 2nd or 3rd design, select it and press



to select another design.

- Press  to delete the design.

- Press  to insert the design.

- If you want to combine two designs only, proceed to step 12.

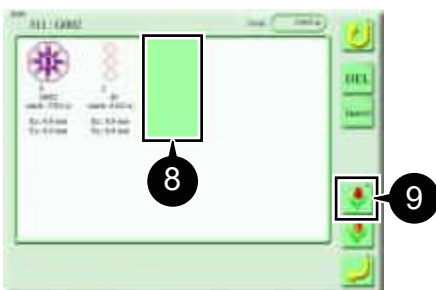

8 Press the side of the 2nd design.

A (green) space for a 3rd design is created.

9 Press 

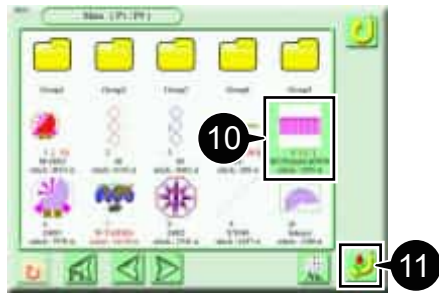

10 Select the 3rd design.

11 Press .

The 3rd design is selected.



12 Select the 1st design.

13 Press .

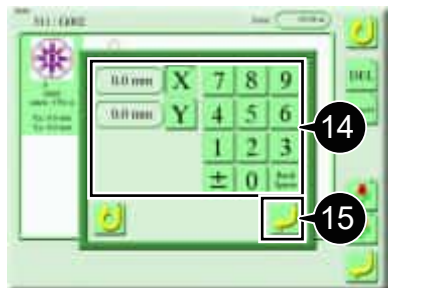

14 Enter the start position (X and Y coordinates) of the 1st design.



- You cannot use the Frame Travel key to enter the start position.

15 Press .

The start position is set.

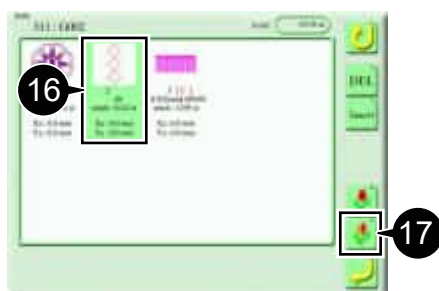

16 Select the 2nd design.

17 Press .

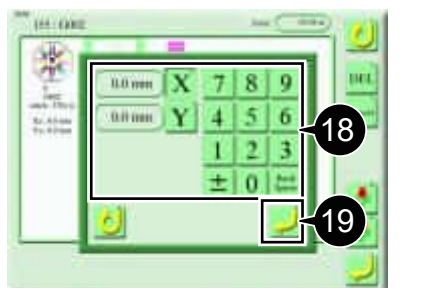

18 Enter the start position (X and Y coordinates) of the 2nd design.

19 Press .

The start position is set.



- If you want to combine two designs only, proceed to step 24.

3. Editing a Design

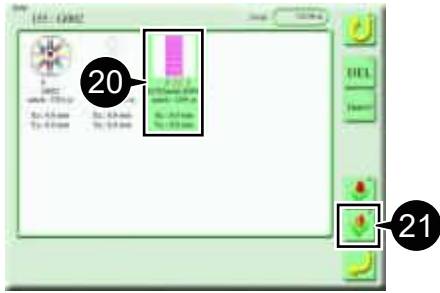

20 Select the 3rd design.

21 Press .

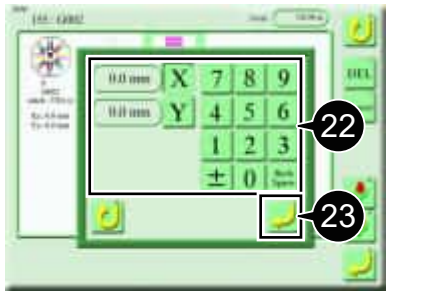

22 Enter the start position (X and Y coordinates) of the 3rd design.

23 Press .
The start position is set.

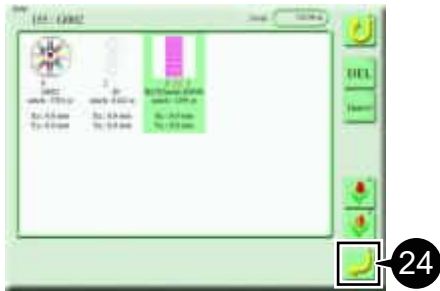

24 Press .
The designs are combined.

4. Design Conversion

You can change the design size and orientation or repeat the design.



- When you set rotation and reversion at the same time, the data will be rotated and then reversed.

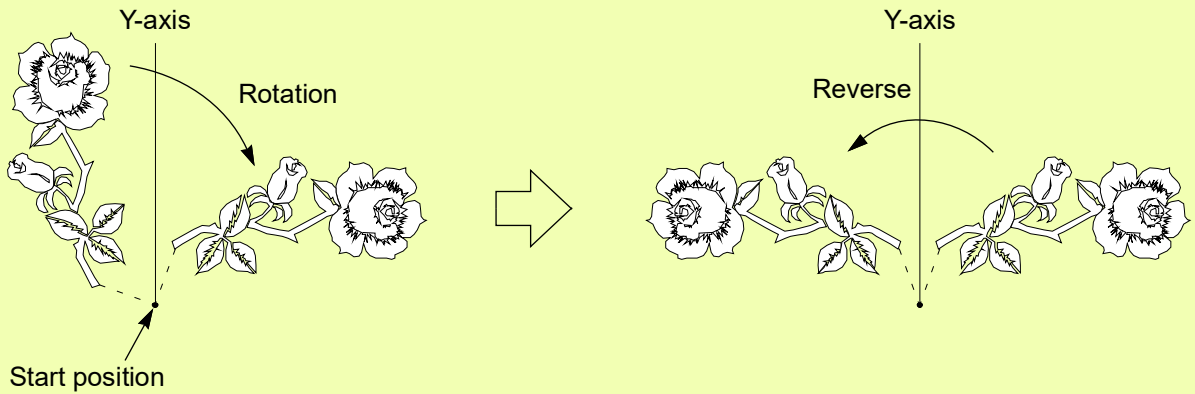

4-1. Scale up/down of design

You can enlarge/reduce your specified design. You can also enlarge/reduce a design at different ratio for the Y (vertical) and X (horizontal) axes.

Example: Y (vertical)/X (horizontal) enlargement at 150%

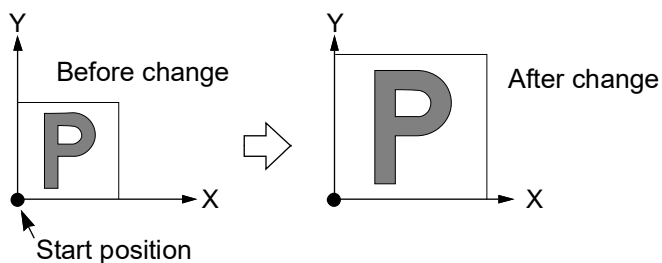

- Press  on the main screen.



- Select your desired design.

- Press .

4. Design Conversion

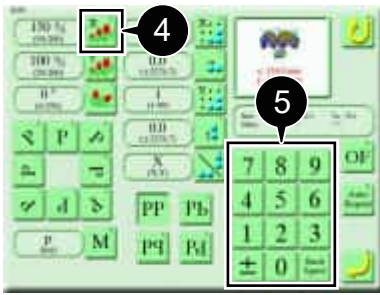

4 Press 

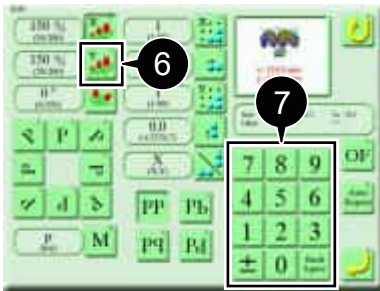

5 Enter the X (horizontal) ratio (for example, 150%).



6 Press 

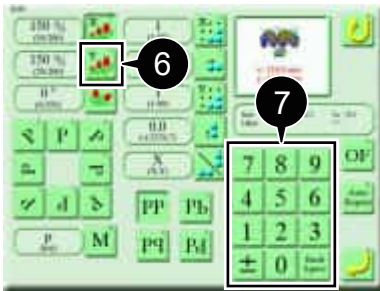

7 Enter the Y (vertical) ratio (for example, 150%).



8 Press 
Your specified ratio value is set.

4-2. Rotation of a design

You can rotate your specified design clockwise by 45° or 1° .

■ To rotate a design by 45°

Example: Rotation by 45°

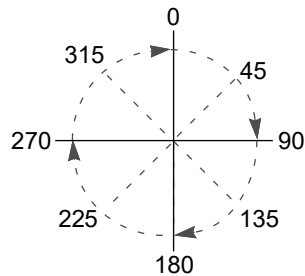
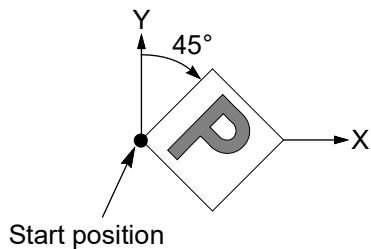

1 Select your desired design on the design selection screen.

2 Press .



3 Press the rotation angle (for example,  for 45°).



4 Press .

Your specified rotation angle value is set.

■ To rotate a design by 1°

Example: Rotation by 5°

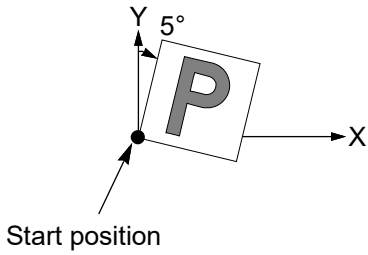

1. Select your desired design on the design selection screen.

2 Press 



3 Press 



4 Enter the rotation angle (for example, "5").

5 Press .
Your specified rotation angle value is set.

4-3. Reverse of design

You can reverse your specified design horizontally.

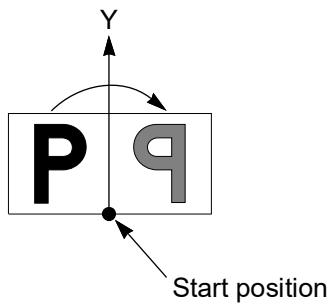

1 Select your desired design on the design selection screen.

2 Press .

3 Press .

The display changes every time you press the icon.

 : Do not reverse

 : Reverse

4 Press .

The design is reversed.

5. Setting for Repeat

You can repeat your specified design.

If the design is enlarged/reduced or rotated/reversed, the changed shape is repeatedly placed.

5-1. Repeating a design by specifying the number of repetitions

You can repeat a design by specifying the number of repetitions and the vertical and horizontal distances.

Example:

- Repeat 3 times horizontally at distances of 50 mm
- Repeat 2 times vertically at distances of 60 mm
- Priority direction: Horizontal

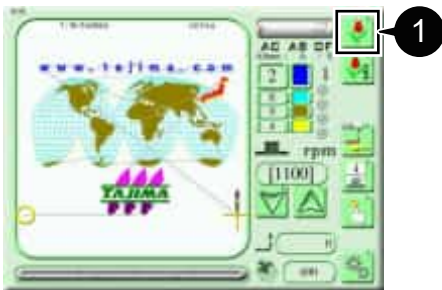
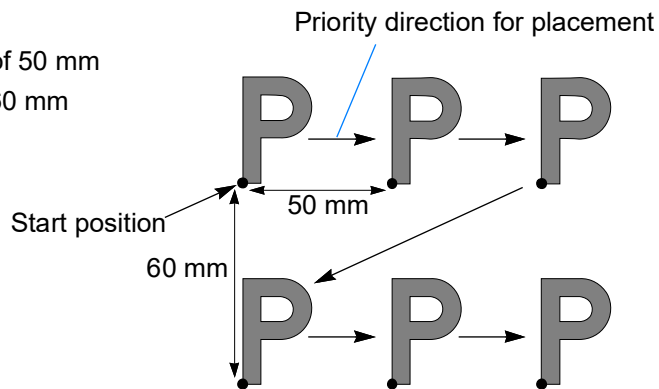

1 Press  on the main screen.



2 Select your desired design.

3 Press .

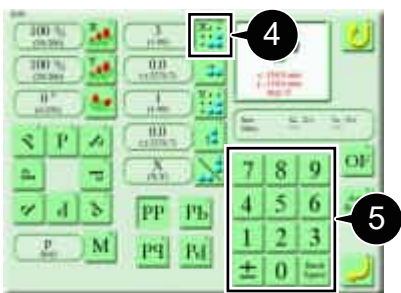

4 Press .

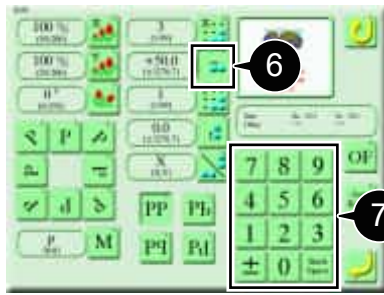

5 Enter the horizontal number of repetitions (for example, "3").



6 Press .

7 Enter the horizontal distance (for example, "+50.0").



- To repeat on the right side, press  to select [+].
- To repeat on the left side, press  to select [-].



8 Press .

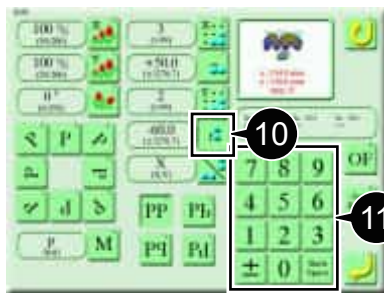

9 Enter the vertical number of repetitions (for example, "2").



10 Press .

11 Enter the vertical distance (for example, "-60.0").



- To repeat on the upper side, press  to select [+].
- To repeat on the lower side, press  to select [-].



12 Press .

Your specified number of repetitions is set.



- The priority direction (X: horizontal)/(Y: vertical) of repetition changes every time you press .

X priority

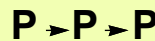

Y priority

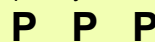

5-2. Repeating a design by automatically calculating the number of repetitions

You can repeat a design by specifying the distance and automatically calculating the number of designs that can be placed in the embroidery space.

Example:

- Horizontal distance: 50 mm
- Vertical distance: 60 mm
- Placement position: Center

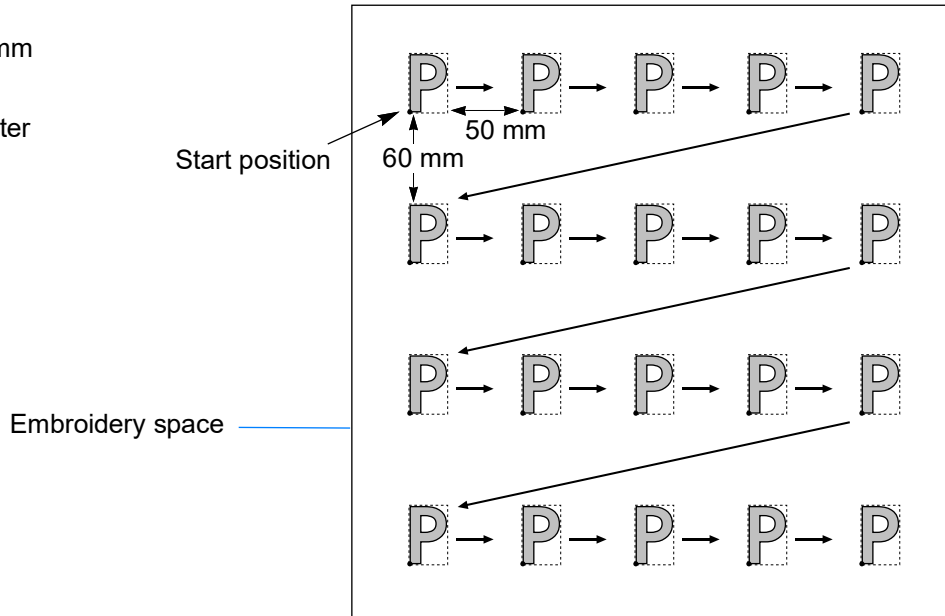

1 Select your desired design on the design selection screen.

2 Press 



3 Press 



4 Enter the horizontal distance (for example, "50.0").

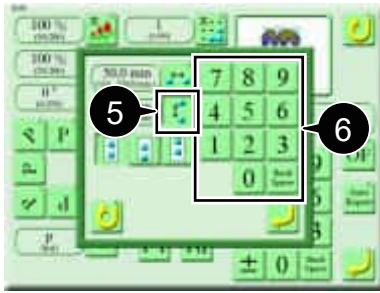



5 Press .

6 Enter the vertical distance (for example, "60.0").



7 Select the placement method.

 : Place in the center

 : Place from the front side

 : Place from the rear side

8 Press .

The number of repetitions is automatically calculated.

9 Press .

Auto repeat is set.

1

2

3

4

5

6

7

8

9

5-3. Reversing or rotating a design alternately

You can place the design by reversing or rotating alternately at the odd numbered times and the even numbered times.

- Reverse based on X-axis

Example: **Pb** (Vertical priority)

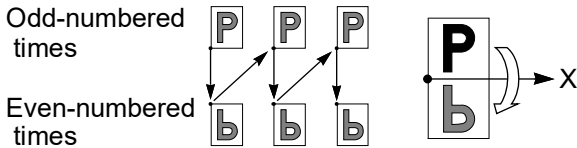

- Reverse based on Y-axis

Example: **Pq** (Vertical priority)

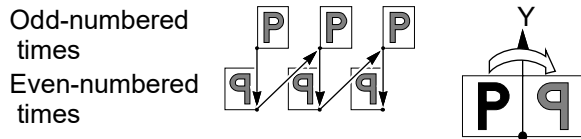

- 180° rotation

Example: **Pd** (Vertical priority)

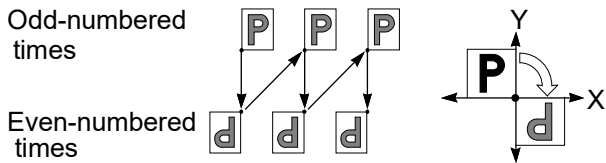

- 1 Select your desired design on the design selection screen.

- 2 Press .



- 3 Configure the X (horizontal) and Y (vertical) numbers of repetitions, distances, and priority directions.

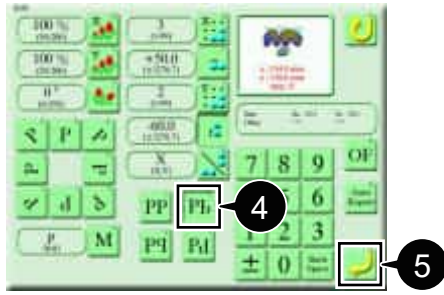

With this setting

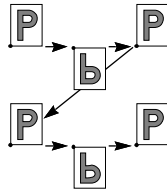

4 Select the method of placement (whether to reverse or rotate them).

Pb : Reverse based on X-axis

Pq : Reverse based on Y-axis

Pd : Rotate 180°

5 Press .

The placement method is set.

1

2

3

4

5

6

7

8

9

6. Editing Stitch Data

6-1. Search by stitch No.

You can search for stitch data (hereinafter "stitches") of designs saved in the machine memory.



- To change stitches, enter the password to set the functional limit level to "SEL".

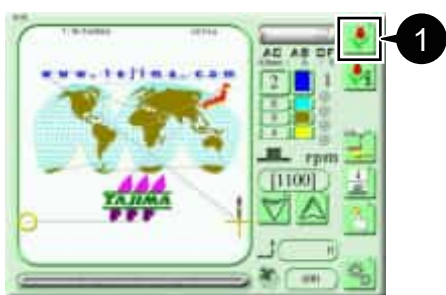

1 Press  on the main screen.

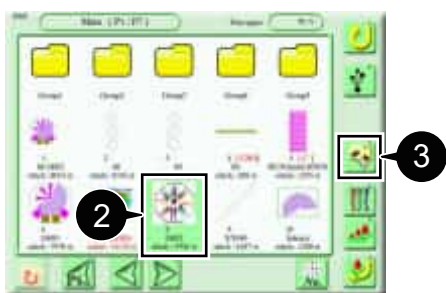

2 Select your desired design.

3 Press .



4 Press .
The design is selected.



5 Press .

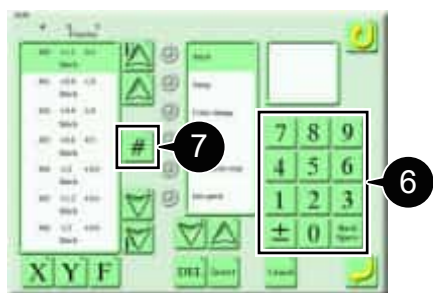

6 Enter your desired stitch No. (for example, "480").

7 Press .

The entered stitch No. is displayed.

6-2. Search by function code

You can select more than one function code to search for stitch data.

For more information on the function codes, operations, and details, see the table below.

Function Code	Operation	Detail
Stitch	Stitches will be sewn.	
Jump	Jumping will be performed. (Frame travel without needle locating)	
Color Change	Stop by color change will be performed.	
ATH	Upper thread or upper/under threads will be trimmed automatically.	Upper thread* ¹ , upper/under threads
Temporary stop	Temporary stop will be performed at stitch or jump.	Stitch, jump
Low speed	A low speed operation will be performed at specified stitch section.	Start S, end S Start J, end J
Satin Stitch	Satin stitch conversion will be performed at specified section.	Start, end
Automatic free-setting offset	Frame travel will be performed according to the setting of automatic offset.	
Sequin	Sequin device will work at specified section.	Start, end, output 1, output 2
Arbitrary block	The items listed on the right will be performed in the specified block.	Maximum RPM, presser foot lower dead point, presser foot stroke, and presser foot timing
Seed beads	Seed beads device will work at specified section.	Start, end, output 1, output 2

*1 The machine trims upper/under threads even if "Upper thread" is selected.

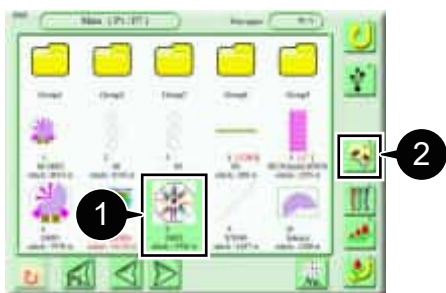

1 Select your desired design on the design selection screen.

2 Press .

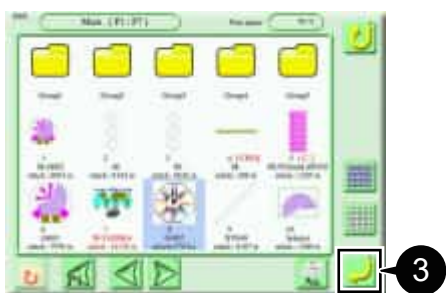

3 Press .
The design is selected.

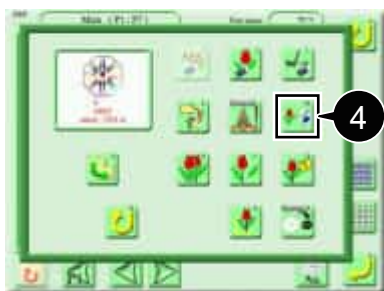

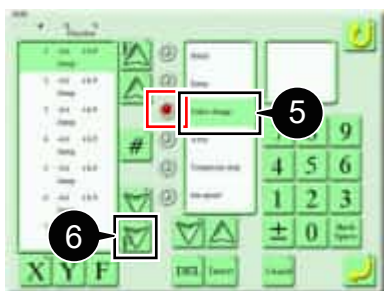

4 Press .



5 Select a function code (for example, "Color change").
The radio buttons at left are lit in red.

6 Start search.

 : Stitches before the selected stitch will be searched.

 : Stitches after the selected stitch will be searched.

Stitches that include the selected function code will be searched in order.



6-3. Modification of stitch

You can change the function code of your specified stitch.



- This operation overwrites the original design. Copy the design in advance as needed.
- If an embroidery stitch after change differs in length from the embroidery stitch before change, all the subsequent stitches in the design will be displaced.



- To change stitches, enter the password to set the functional limit level to "SEL".

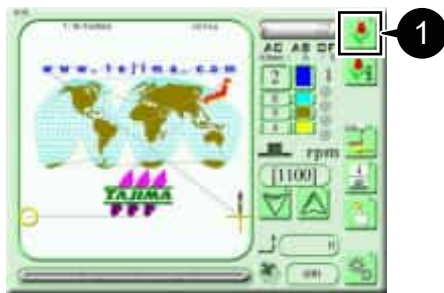

1 Press  on the main screen.

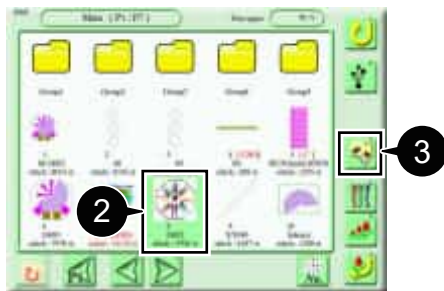

2 Select your desired design.

3 Press .

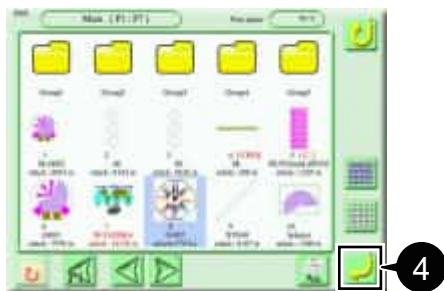

4 Press .
The design is selected.



5 Press .

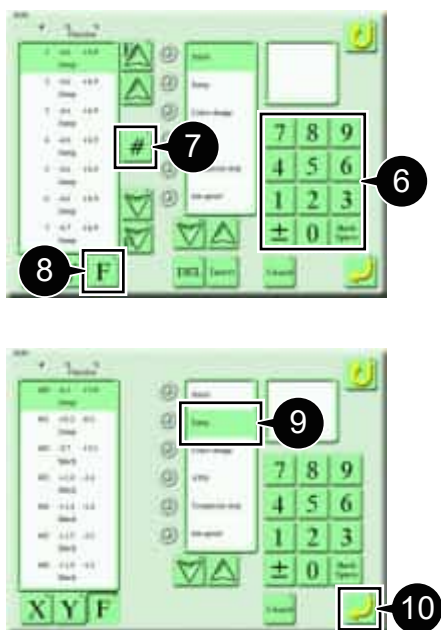

6 Enter the stitch No. (for example, "480") for which you want to change a function code.

7 Press .

8 Press .

9 Select a function code (for example, "Jump").

10 Press .

The function code is changed.

6-4. Insertion of stitch

You can insert a new stitch before the selected stitch.



- This operation overwrites the original design. Copy the design in advance as needed.
- Inserting a stitch with a length displaces all the subsequent stitches in the design.



- To insert a stitch, enter the password to set the functional limit level to "SEL".

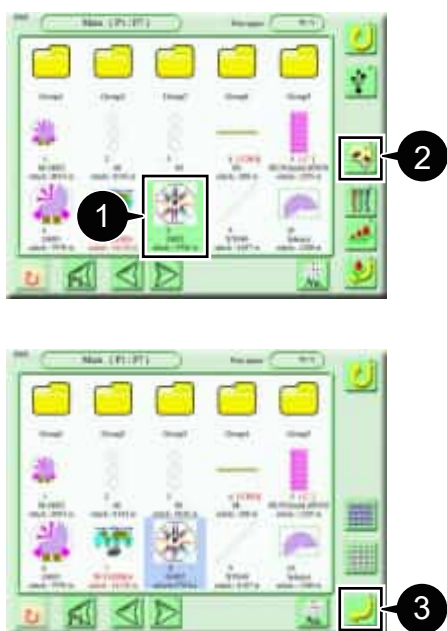

1 Select your desired design on the design selection screen.

2 Press .

3 Press .

The design is selected.



4 Press 

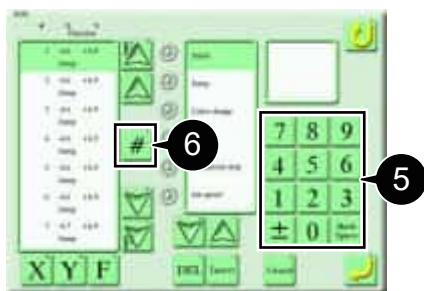

5 Enter the stitch No. for the new stitch you want to insert (for example, "480").

6 Press 

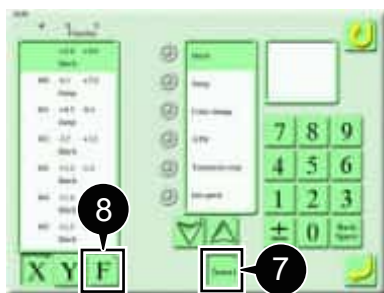

7 Press 

8 Press 

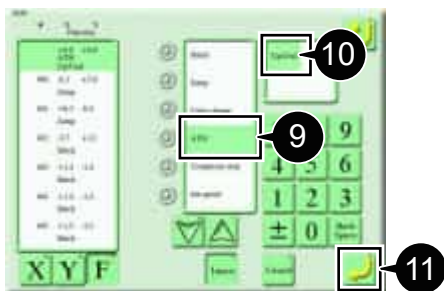

9 Select a function code (for example, "ATH").

10 Select a thread trimming method (for example, "Up/Und").

11 Press 

A new stitch is inserted.

1

2

3

4

5

6

7

8

9

6-5. Deletion of stitch

You can delete your specified stitch.



- This operation overwrites the original design. Copy the design in advance as needed.
- Deleting a stitch with a length displaces all the subsequent stitches in the design.



- To delete a stitch, enter the password to set the functional limit level to "SEL".

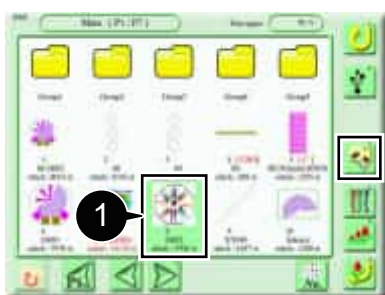

1 Select your desired design on the design selection screen.

2 Press .



3 Press .
The design is selected.



4 Press .

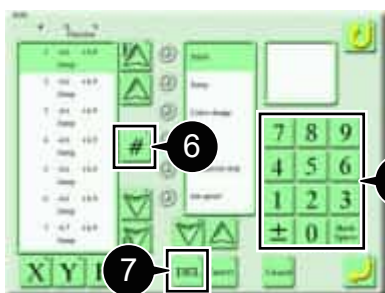

5 Enter the stitch No. for the stitch you want to delete (for example, "480").

6 Press .

7 Press .

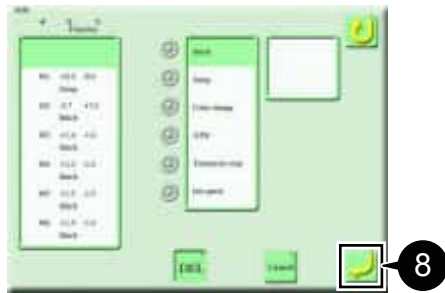

- 8 Press .
Your specified stitch is deleted.

6-6. Removal of tiny stitches

You can remove tiny stitches by merging them into the previous and next stitches.

This feature can reduce thread casts-off and thread breakages.

You can process multiple designs at once if they are displayed in the same screen.

The following example shows how to remove 0.5 mm and smaller stitches by selecting two designs.



- This operation overwrites the original design. Copy the design in advance as needed.

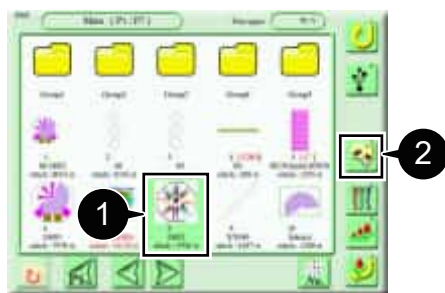



- 1 Select your desired design (the 1st design) on the design selection screen.

- 2 Press .



- 3 Select the 2nd design.



- All designs are selected when  pressed.
- All designs are deselected when  pressed.

- 4 Press .
The design is selected.



5 Press .

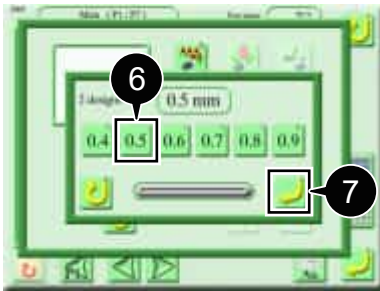

6 Press .



• If you select one design and press , the number of stitches to be removed is displayed.

7 Press .



8 Press .

0.5 mm and smaller stitches are removed.

6-7. Arbitrary block settings

Follow the steps below to apply the following items to the desired block (between stitch numbers). Up to 8 blocks (8 ways) can be created.

Maximum RPM, presser foot lower dead point, presser foot stroke, and presser foot timing

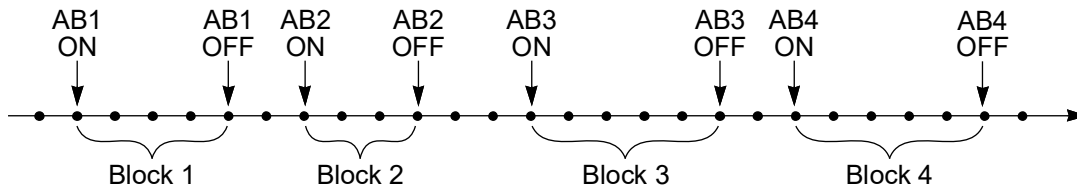

- When setting an arbitrary block, enter the password to set the functional limit level to "SEL".
- For items overlapping with the parameter setting values or step unit set values, the setting values here will take priority.
- One block (e.g., 100th to 300th stitches) cannot contain another block (e.g., 120th to 170th stitches).
- ON (start) and OFF (end) should be set in pairs.

This section explains how to apply the following items, using the 480th to 500th stitches as "Block 1".

- Maximum RPM: 900 rpm
- Presser foot lower dead point: 1.0 mm

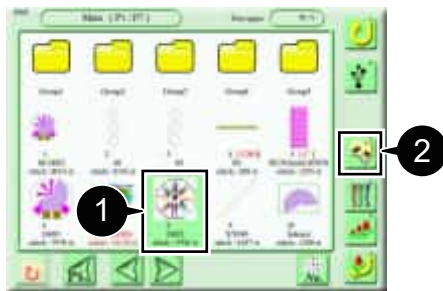

1 Select your desired design on the design selection screen.

2 Press .

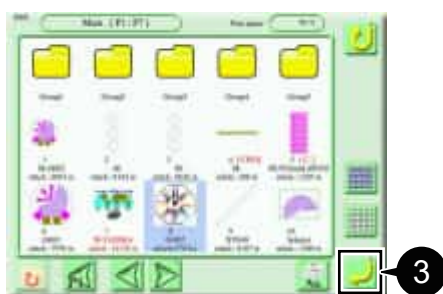

3 Press .
The design is selected.



4 Press .

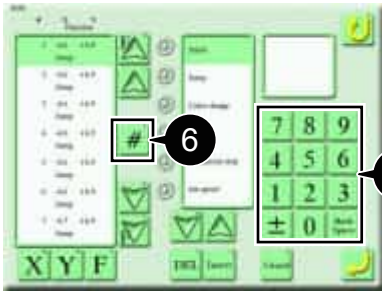

5 Enter "480".

6 Press .

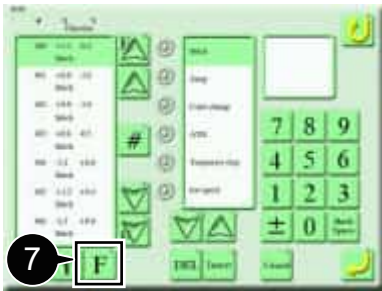

7 Press .

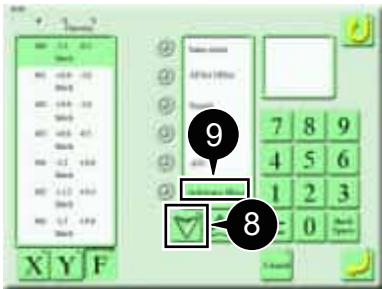

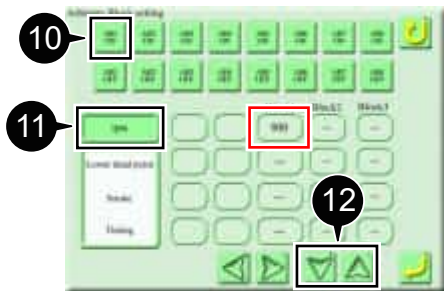

8 Press .

9 Press "Arbitrary block".





10 Press .

11 Press "rpm".

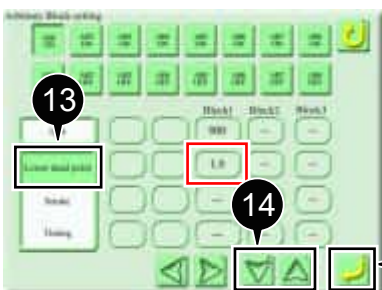
12 Press   to set the maximum RPM (red frame) for Block 1 to "900".



13 Press "Lower dead point".

14 Press   to set the lower dead point (red frame) for Block 1 to "1.0".

15 Press .

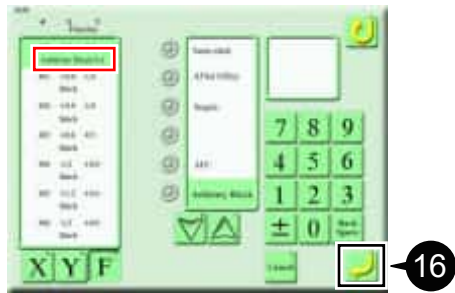

16 Press .

The "Arbitrary block S-1" (red frame) is set at the 480th stitch.

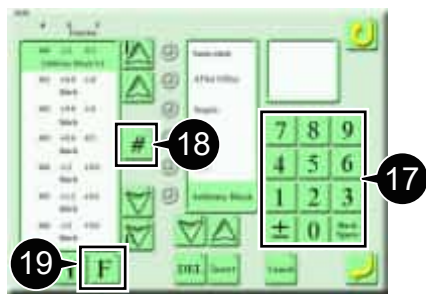

17 Enter "500".

18 Press .

19 Press .

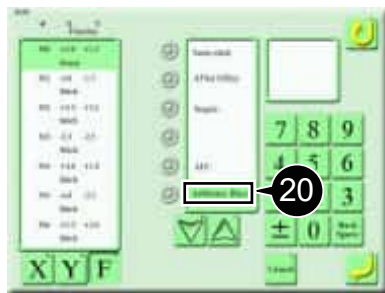

20 Press "Arbitrary block".

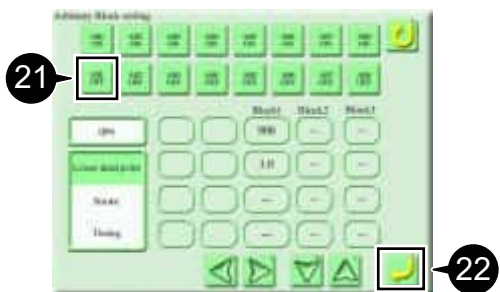

21 Press .

22 Press .

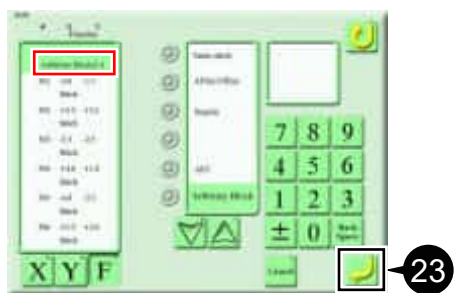

23 Press .

The "Arbitrary block E-1" (red frame) is set at the 500th stitch.



• While the current stitch is in the arbitrary block, the presser foot setting value is displayed in blue in the upper right corner of the main screen to distinguish between ON and OFF for the arbitrary block. For more information on presser foot setting value, refer to "Chapter 1 5-1. Main screen".

Chapter 6

Various Functions

1. Moving the Offset Frame

1-1. Outline of function

To make it easy to replace the frame or fabric, set an applique fabric, and check the embroidery finish, you can automatically move the frame to an arbitrary position (where work is easy) after or during embroidery. To use this feature, register the position where to move the frame (hereinafter the "offset position") in advance. There are three offset frame movement types, each of which should be used at different times.

■ Automatic Offset

Move the frame to the offset position upon completion of embroidery.

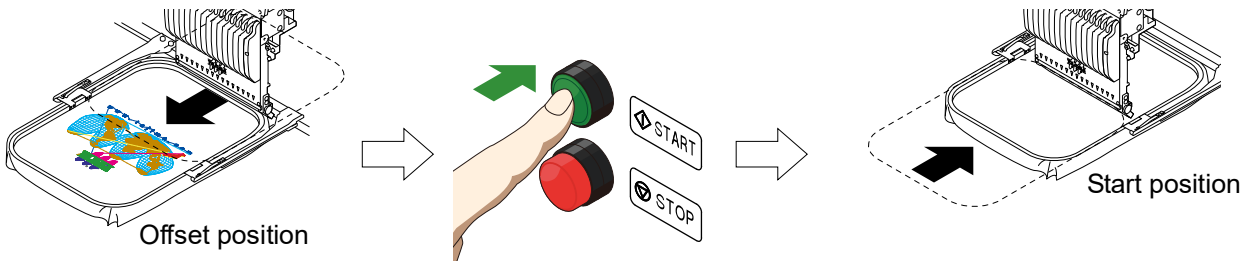

The frame moves to the offset position upon completion of embroidery.

Once you replace the fabric and start the machine, the frame automatically moves to the start position and embroidery starts.

[If you have registered the offset middle position]

The frame moves via the offset middle position to the offset position upon completion of embroidery.

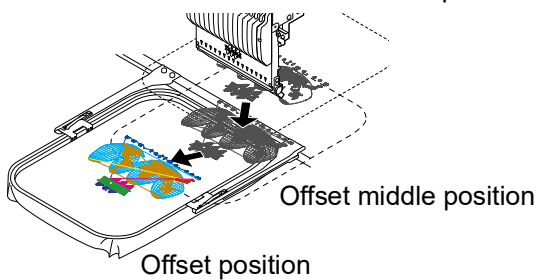

- Registering the offset middle position also allows you to move the frame to avoid the head while performing placing embroidery.
- You can register two offset middle positions.

■ Automatic free-setting offset

It is the setting that the machine stops and the frame moves to the offset position automatically at the specified stitch position.

Moving the frame to the front side makes it easy to set an applique fabric, for example.

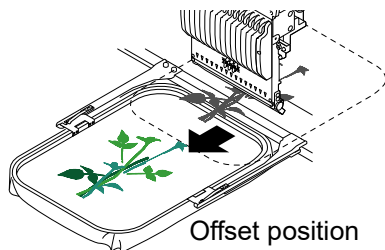

The frame automatically moves to the offset position during embroidery.

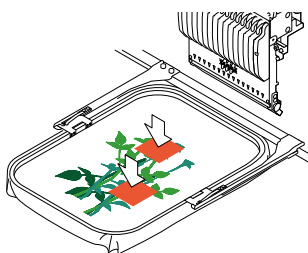

Place the applique fabric.

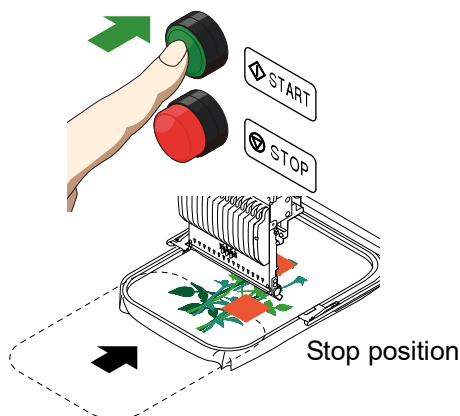

When the machine starts, the frame automatically returns to the stop position and resumes embroidery.

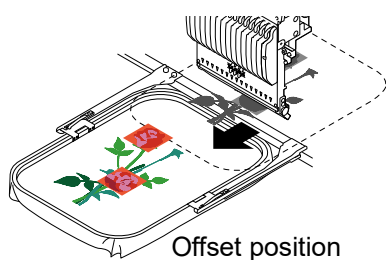

The frame automatically moves to the offset position upon completion of embroidery.



- Register the offset position in advance.
- The frame moves to the offset position during and after embroidery.

■ Automatic color change offset

It is the setting that the machine stops and move to the offset position automatically at the color change position during embroidery.

Moving the frame to the front side makes it easy to set an applique fabric, for example.

The movement of the frame is the same as that for automatic free-setting offset.

1-2. Registration of the offset position

You have to register an offset position on a design by design basis.

The following example shows how to register the start position, the offset middle position (OF1), and the offset position (OF2).

- The offset position is registered for each design. You do not need to register it again the next time you embroider the design.

CAUTION

- Do not put your hands on the table when you operate the machine. Failure to observe this may result in injury due to the frame travel.

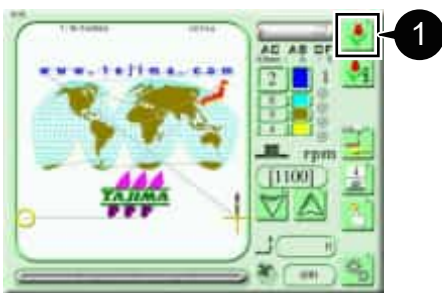

1 Press  on the main screen.



2 Select your desired design.

3 Press .



4 Press  .
The offset settings screen appears.

- If "design start position" is registered in the design, you can move the frame to the "design start position" by pressing .

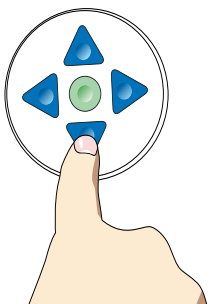

• Start position

5 Using the frame travel key, move the frame to the start position.

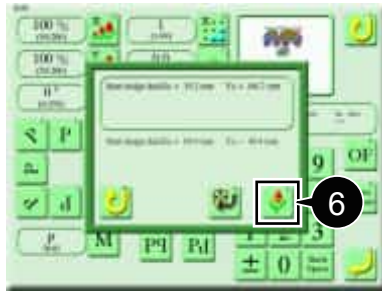

6 Press .
The current frame position is set as the start position.

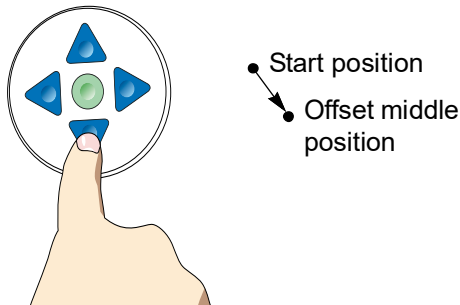

7 Using the frame travel key, move the frame to the offset middle position.



8 Press .
The current frame position is set as the offset middle position.



- You can register up to two offset middle positions.
- If the offset middle position is not registered, this position becomes the offset position. Then press  in step 10.

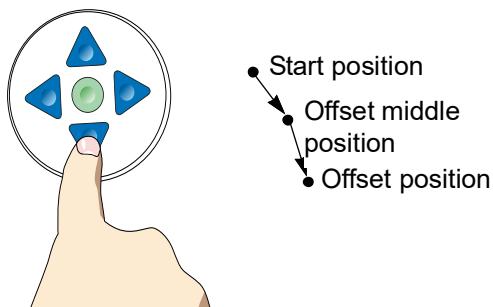

9 Using the frame travel key, move the frame to the offset position.



10 Press .
The current frame position is set as the offset position.



- Press  if two offset middle positions are registered.



- 11 Press  .
Each position is registered.

1-3. Erasing the offset position

CAUTION

 Do not put your hands on the table when you operate the machine. Failure to observe this may result in injury due to the frame travel.



- 1 Select your desired design on the design selection screen.

- 2 Press  .



- 3 Press  .



- 4 Press  .

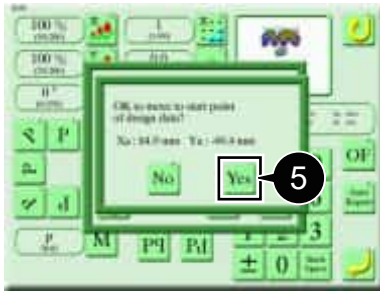

5 Press  .

The frame moves to the start position.

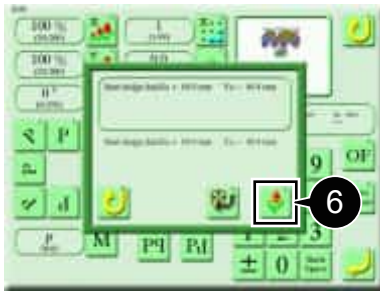

6 Press  .



7 Press  .



8 Press  .

If the design start position becomes the same as the position of offset 1, the offset position is deleted.

1

2

3

4

5

6

7

8

9

1-4. Moving the frame at an arbitrary stitch

The following example shows how to insert an automatic free-setting offset code at the 480th stitch.



- To use this feature, enter the password to set the functional limit level to "SEL".
- Register the offset position in advance.

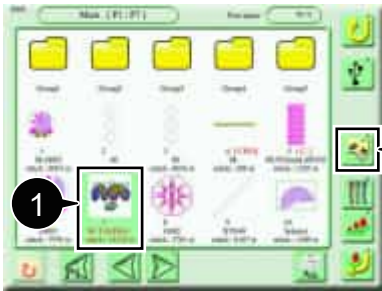

1 Select your desired design on the design selection screen.

2 Press .

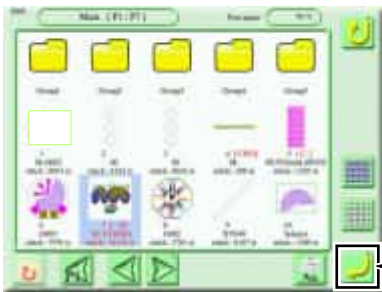

3 Press .
The design is selected.



4 Press .

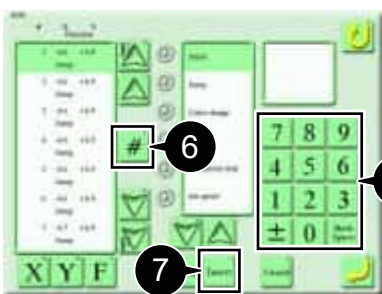

5 Enter "480".

6 Press .

7 Press .

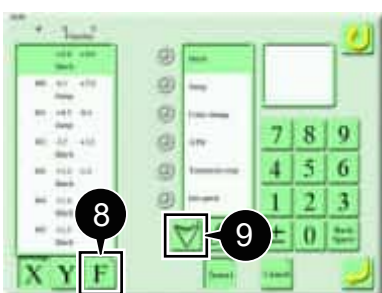

8 Press .

9 Press .

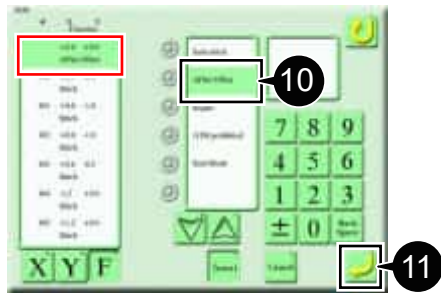

10 Select "AFSet Offset".
An automatic free-setting offset code (red frame) appears at the 480th stitch.

11 Press .
An automatic free-setting offset code is inserted.

1-5. Moving the frame at the color change position

The following example shows how to add an offset (OF) between the needle bar steps 4 and 5.





- Register the offset position in advance.



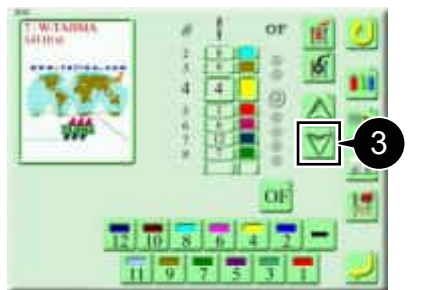

1 Select your desired design on the design selection screen.

2 Press .

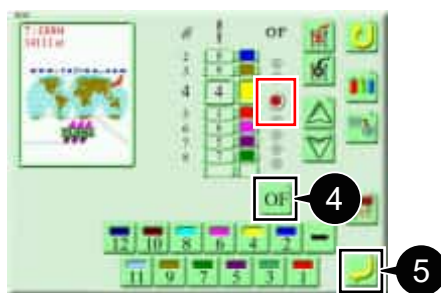

3 Press  to select needle bar step 4.



4 Press .
An automatic color change offset (OF) is lit in red.

5 Press .
An automatic color change offset is added.

2. Selecting Active Heads

2-1. Outline of function

You can select and activate particular heads.

This feature allows you to activate only the odd- or even-numbered heads or specify the heads you want to activate for each needle bar step.

■ Activating only the odd- or even-numbered heads

Odd-numbered heads only

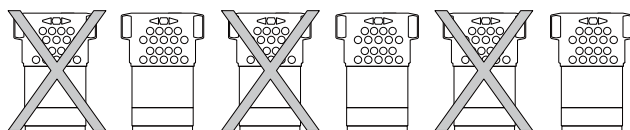

Even-numbered heads only

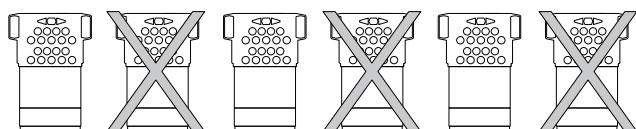

■ Specifying active heads for each needle bar step

You can register patterns of active heads in advance and specify active heads for each needle bar step.

Step 1

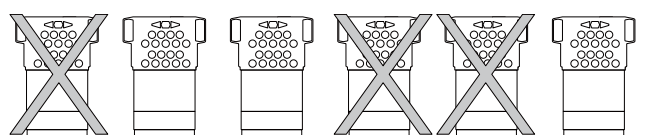

Needle bar No. 9

The arrows ↓ show the needle bars used for embroidery.

Step 2

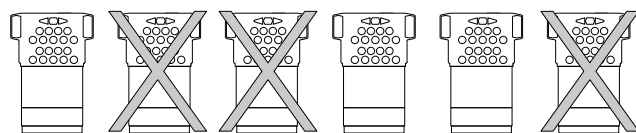

Needle bar No. 1



- You can register up to 20 patterns.

2-2. Activating only the odd- or even-numbered heads

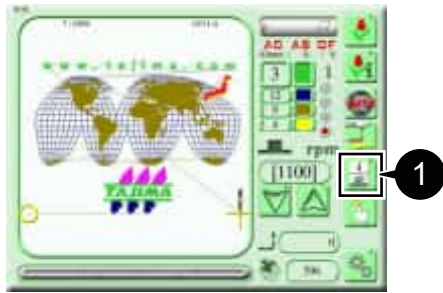

1 Press  on the main screen.

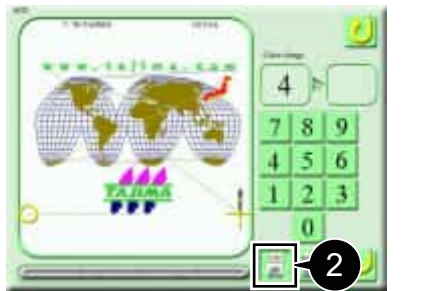

2 Select active heads.



: Activate odd-numbered heads only



: Activate even-numbered heads only



: Activate all heads

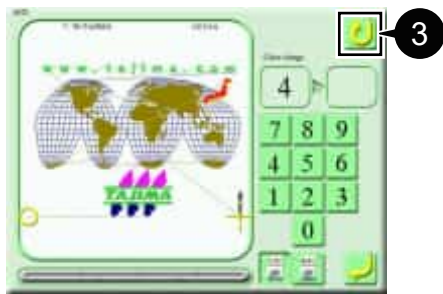

3 Press .

Only the selected heads are activated.

1

2

3

4

5

6

7

8

9

2-3. Specifying active heads for each needle bar step

■ Registering patterns of active heads

You can register combinations of active heads as patterns.

The following example shows how to register patterns under the conditions:

Pattern No.	Active head number
P1	1, 4, 5
P2	2, 3, 6



- This setting is registered for each design. You do not need to register it again the next time you embroider the design.



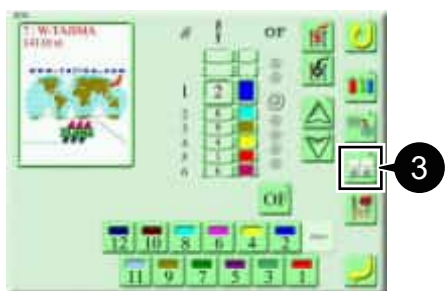

1 Select your desired design on the design selection screen.

2 Press .

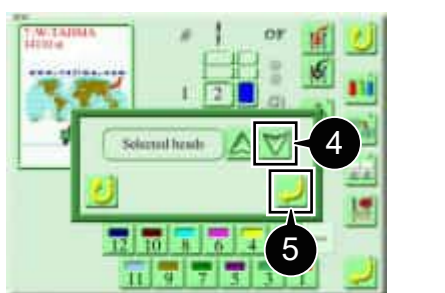

3 Press .



4 Press  to select "Selected heads".

5 Press .

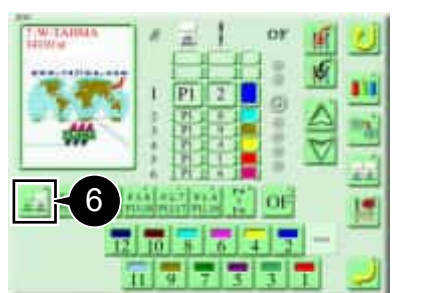

6 Press .

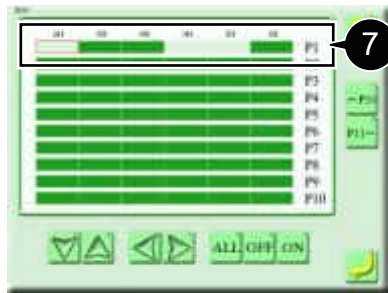

7 Activate only head Nos. 1, 4, and 5 of P1 (lit green).

ALL : Select or deselect all

OFF :  Suspended head

ON :  Active head



8 Activate only head Nos. 2, 3, and 6 of P2 (lit green).



9 Press .

The patterns of active heads are registered.

■ Registering the patterns for each needle bar step

You can set the pattern numbers for each needle bar step. This allows you to automatically change the active and suspended heads for each needle bar step.

The following example shows how to register pattern numbers for each needle bar step under the conditions:

Needle bar step	Pattern No. Numbers in () mean active heads
1	P6 (1, 2, 3)
2	P7 (4, 5, 6)



- This setting is registered for each design. You do not need to register it again the next time you embroider the design.



1. Select your desired design on the design selection screen.

2 Press .

2. Selecting Active Heads

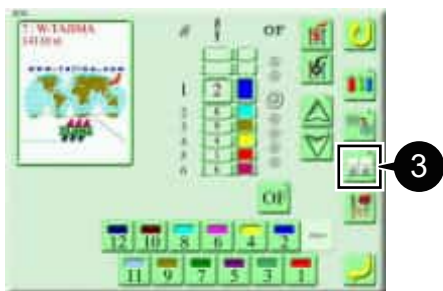

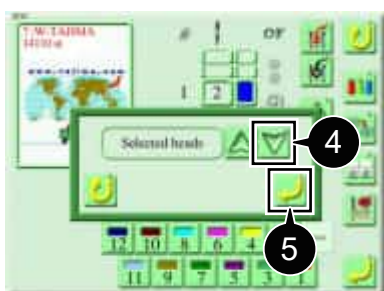

3 Press .

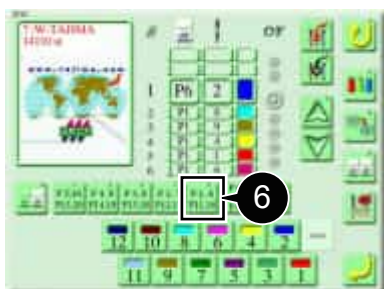

4 Press  to select "Selected heads".

5 Press .





6 Press  twice.

P6 is set for needle bar step 1.

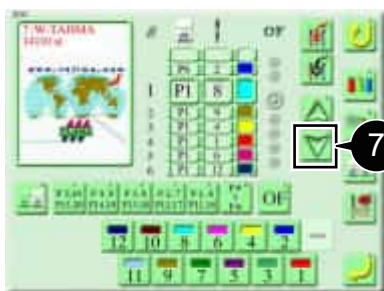

• To set the same pattern as the previous step, press



7 Press  to select needle bar step 2.

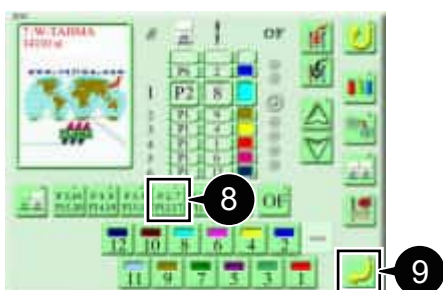

8 Press .

P2 is set for needle bar step 2.

9 Press .

Each needle bar step is configured with the active head patterns.

3. Marking









3-1. Outline of function

Before you perform applique embroidery or placing embroidery, you can create basting data (marking design) to help to correctly place the material.

There are two types of marking designs: "Point" and "Contour".

- Point: Create the marking design manually.
- Contour: The marking design (design contour) is automatically created.

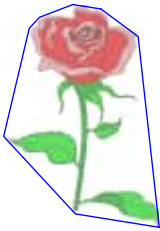
Markings are available in the following combinations. Use the combinations to best suite your purpose.

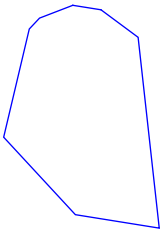
Marking design	With or without design	Embroidery image	Description
Point 	With design 		Register the point and design in the machine memory.* ¹
	Without design 		Register only the point in the machine memory.
Contour 	With design 		Register the contour and design in the machine memory.* ¹
	Without design 		Register only the contour in the machine memory.

*¹ If you select "With design", an automatic free-setting offset code is automatically appended to the end of the marking design. If you register an offset position, the frame automatically moves to the offset position after the embroidery of the marking design. For details, refer to "Chapter 6 1. Moving the Offset Frame".

3-2. Creating a marking design

The following example shows how to set the marking type to "Point", create a marking "with a design", and set the stitch length to "5.0 mm".



- Once you create a marking design, it is automatically registered as "M-" in a free number on the design selection screen.
- If you set the marking type to "Contour", skip steps 10 to 15 and proceed to step 16 because the marking is automatically created.

CAUTION

- Do not put your hands on the table when you operate the machine. Failure to observe this may result in injury due to the frame travel.

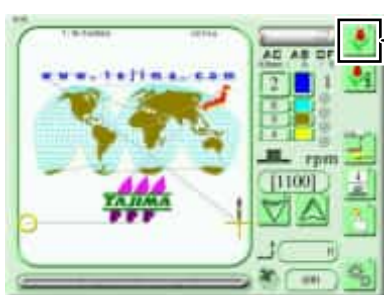

- 1 Press  on the main screen.



- 2 Select your desired design.

- 3 Press .



- 4 Press .



- 5 Press .

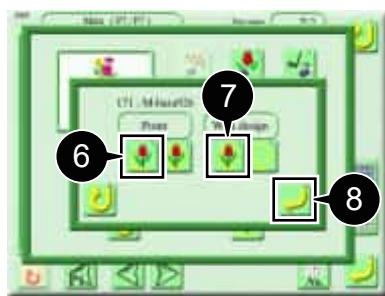

6 Press 

7 Press 

8 Press 

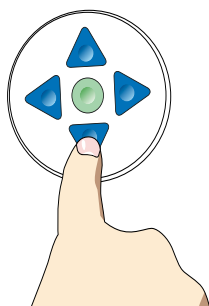

Start position



9 Using the frame travel key, move the frame to the start position of the design.



- You can specify up to 10 marking points.
- The frame moves to the design start position by pressing



10 Press 

The start position of the design is set.

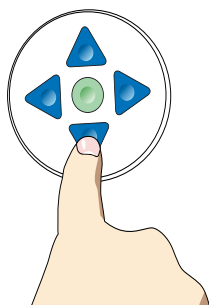
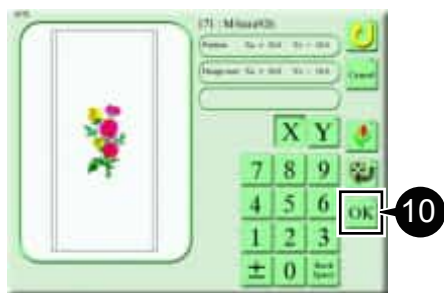

Point 1

Start position



11 Move the frame to the point 1 by pressing the frame travel key.



- Enter the coordinates of point 1 (based on the start position) using numeric keys and press  and



to move the frame.

12 Press 

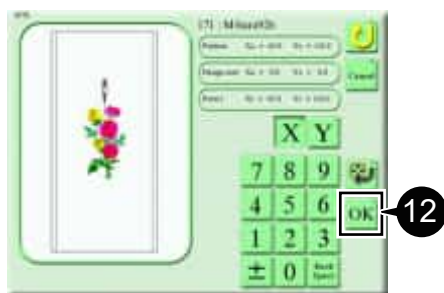

Point 1 is registered.

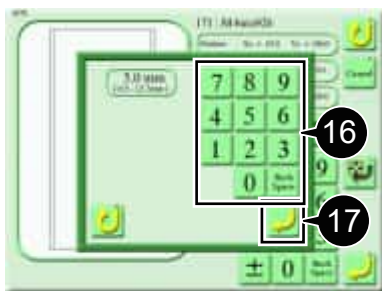
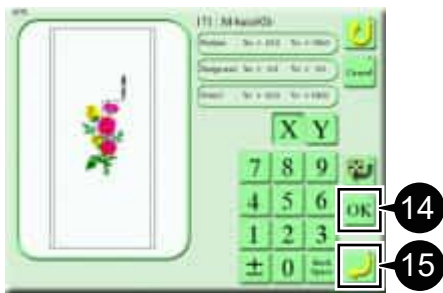
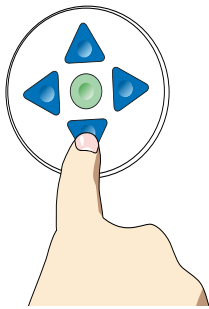



13 Move the frame to the point 2 by pressing the frame travel key.



- Enter the coordinates of point 2 (based on point 1) using numeric keys and press  and  to move the frame.

14 Press .

Point 2 is registered.



- Once you register two or more points, a new marking design is automatically registered.

15 Press .

The points have been set. Numerical keys for setting the stitch length is displayed.

16 Enter "50".

17 Press .

The marking design is registered.

Chapter 7

Maintenance

1. Precautions for Maintenance

WARNING

- ❗ Be sufficiently trained and instructed on how to perform maintenance work such as lubrication and adjustment before actually doing so.
- ❗ Greasing, inspection of drive systems, and repair of the machine must be performed by the distributor or the service personnel assigned and trained by TAJIMA. Failure to observe this may result in injury, electric shock, or other serious accident.
- ❗ Ensure the safety by turning OFF the machine power and removing the power plug from the outlet before starting maintenance work.
- ❗ Upon completion of maintenance work, re-install all the covers you removed. Running the machine with covers removed may result in being caught in the moving parts.

CAUTION

- ❗ Perform maintenance work periodically. Lack of maintenance may result in early deterioration or failure of parts. Damage arising from lack of maintenance may be excluded from the scope of guarantee.
- ❗ If the machine is not used for a long period, turn ON the power switch in regular intervals. Although each card of the machine has a backup battery, data may be lost in about one month because voltage of the battery will come down gradually due to discharge when the power switch is turned OFF.
- ❗ When you work underneath the machine table, ensure sufficient lighting.

2. Maintenance Item List

Daily maintenance and inspection are important to prevent machine trouble.
Use the following maintenance and inspection items for maintenance plans, etc.

■ Maintenance and inspection items

Frequency	Parts	Maintenance and inspection content
Once per 5 to 6 hours	Rotary hook	Lubrication
Every day	Inside of the cylinder bed	Cleaning
Once/week	Head and its surroundings	Cleaning
	Inside of head	Lubrication
	Drive system	Cleaning
	Presser foot shaft	Cleaning
Once every three months	Inside of head	Greasing
	Each belt in main shaft drive system	Periodic inspection
	X- and Y-axis drive belts	Periodic inspection
	Rotating, sliding section	Periodic inspection
Once every six months	Cylinder bed gear	Greasing

3. Cleaning

Clean accumulated lint and dust, using a commercially available cleaning tool, an air gun, and the supplied brush.

3-1. Inside of the cylinder bed

Frequency: Every day

■ Manually operating the ATH (automatic thread trimming and holding device)

Open the movable knife of the ATH before cleaning, using the operation panel.

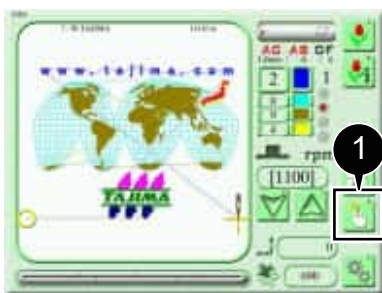

1 Press  on the main screen.

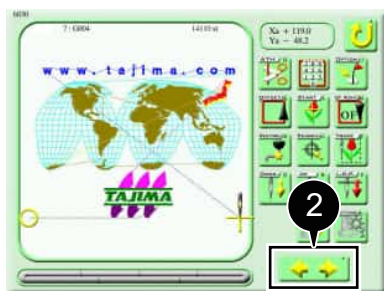

2 Press 

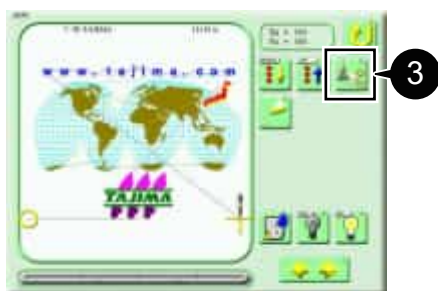

3 Press 



4 Press .
The movable knife of the ATH opens.

■ Cleaning of the interior

In ATH cleaning mode, use a brush or air gun and clean the interior of the cylinder bed while the movable knife is open.



- See "■ Manually operating the ATH (automatic thread trimming and holding device)" (→p. 137) for ATH cleaning mode.

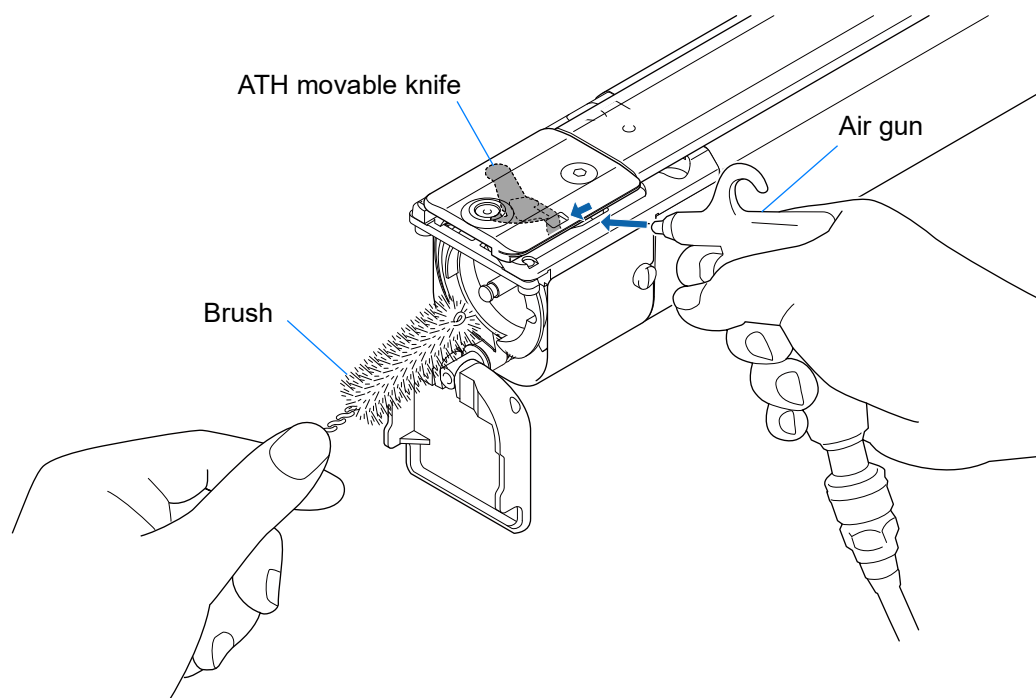

3-2. Head and its surroundings

Frequency: Once a week

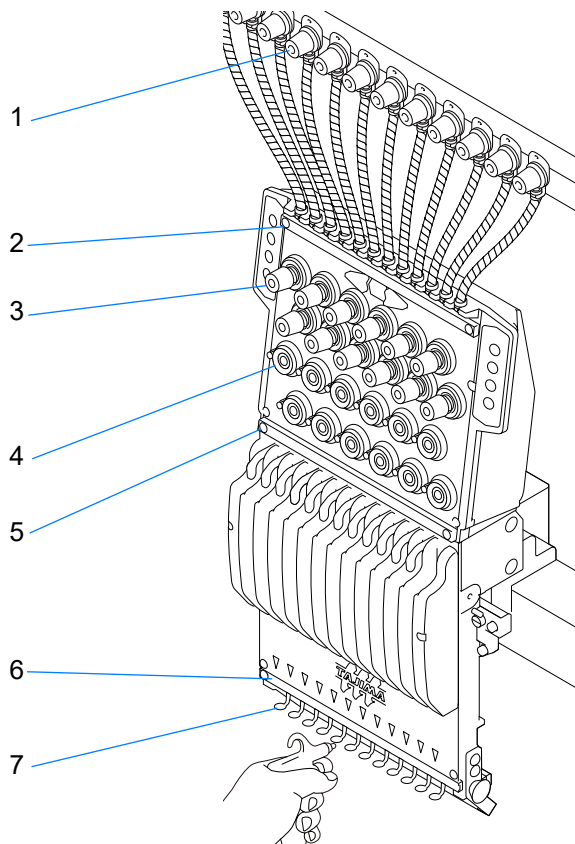

	Cleaning area
1	First thread tension regulator
2	Thread presser (1)
3	Second thread tension regulator
4	Thread breakage detector
5	Thread presser (2)
6	Upper thread lock
7	Presser foot

3-3. X-axis drive system, Y-axis drive system

Frequency: Once a week

Using the air gun, air-blow the interior from the slits of the drive system.

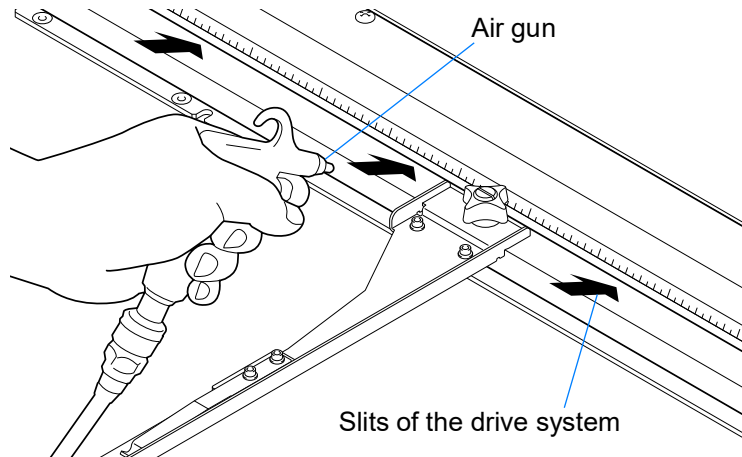

3-4. Presser foot shaft

Frequency: Twice a week

Thread and dust may adhere and movement of the presser foot shaft may be impaired. Use an appropriate tool, such as an air gun and clean the presser foot shaft.

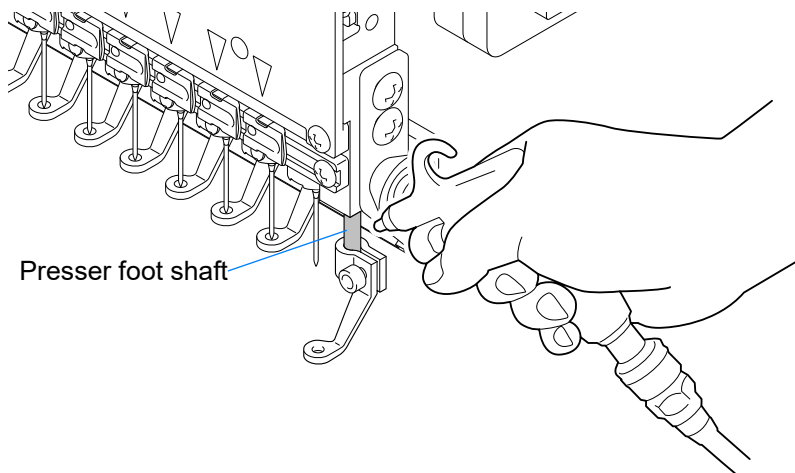

Press  on the tension base to lower the presser foot, and clean the shaft.





4. Lubrication

Perform lubrication using the supplied oiler.

WARNING

-  Maintenance work should be performed by the personnel who is trained adequately.
-  To prevent an accident due to an unexpected startup, be sure to turn off the power before accessing the machine.

CAUTION

-  Use only TAJIMA's genuine TF oil or equivalent (Viscosity grade = VG20).
-  Pour a few drops of oil for lubrication. Using too much oil may cause the oil to drip or scatter, possibly dirtying or staining the fabric or thread. Wipe off excess oil with a cloth.

4-1. Rotary hook

Frequency: Once per 5 to 6 hours



- To lubricate a lubrication hole, attach the nozzle (accessory) to the tip of the oiler.

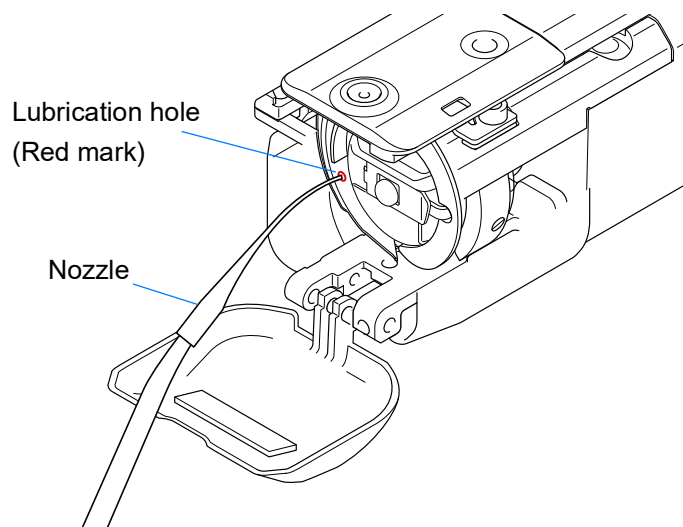

4-2. Inside of head

Frequency: Once a week

Internal lubrication

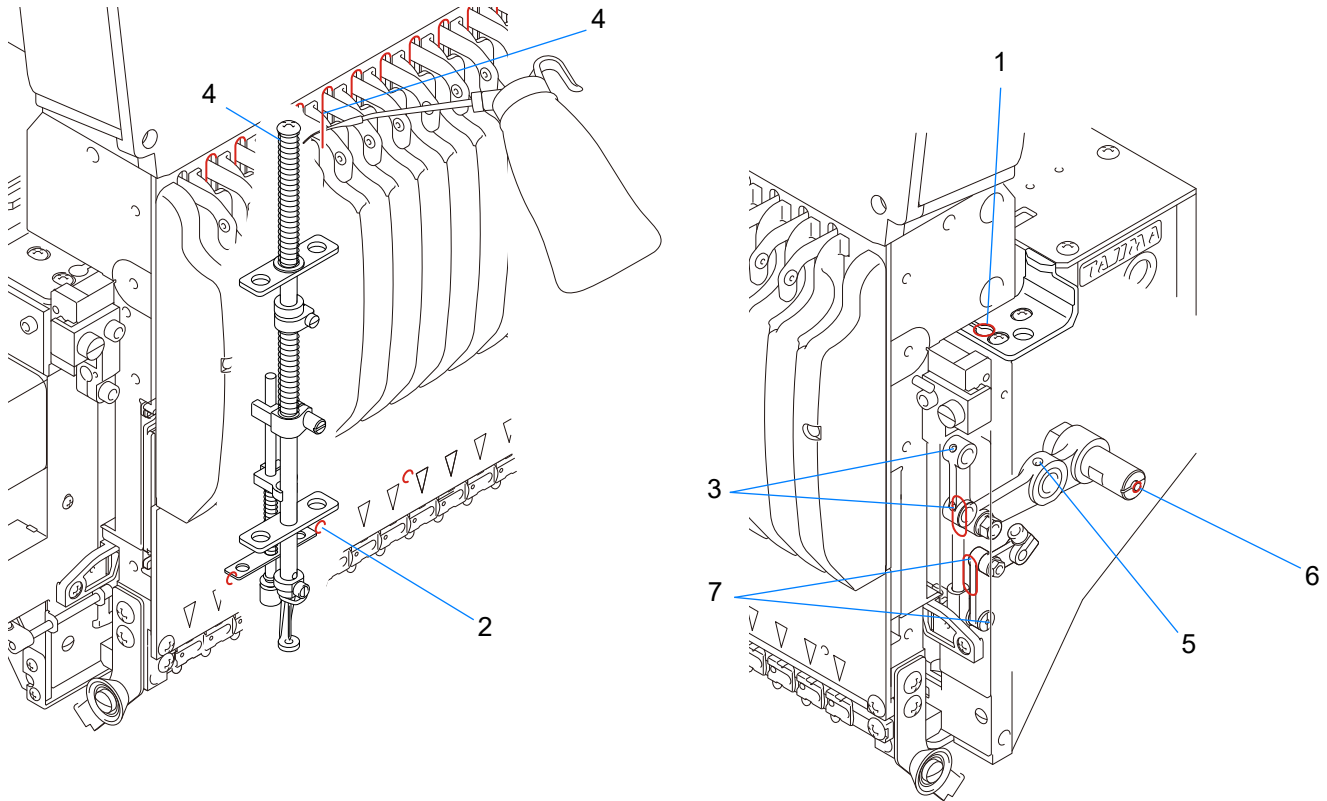

	Lubricating spot
1	Needle bar drive shaft
2	Needle bar (spot indicated by red mark)
3	Lubrication hole of connecting part
4	Needle bar (all needles)
5	Lubrication hole of needle bar lever
6	Lubrication hole of stepped pin
7	Drive parts of presser foot

5. Applying grease

This section contains information intended for use by service personnel assigned and trained by TAJIMA.

⚠ WARNING

- ❗ Applying grease must be performed by the distributor or the service personnel assigned and trained by TAJIMA.
- ❗ To prevent an accident due to an unexpected startup, be sure to turn off the power before accessing the machine.

⚠ CAUTION

- ❗ Use a grease specified (described below) by TAJIMA or equivalent to keep the lubricity inside of the head normally. Use of grease other than above could cause trouble due to deterioration of the lubricity.

Manufacturer of grease specified by TAJIMA: NIPPON GREASE Co., Ltd.				
Parts to be greased	Part name	Item No.	Base oil	Thickener
Cylinder bed gear & gear box gear	KING STAR EP NO.2: 400G	750103004000	Refined mineral oil (about 75%)	Lithium soap (About 15%)
Inside of head	NIG LUBE PG: 300ML	750104001000	Olefinic synthetic oil	Lithium soap



- For questions regarding greasing and how to obtain grease, consult the distributor.

5-1. Cylinder bed gear

Frequency: Once every six months

Apply grease to the cylinder bed gears, using grease specified by TAJIMA.

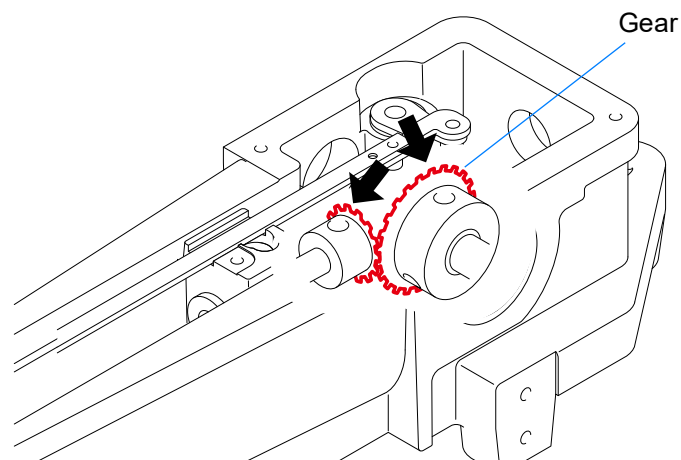

5-2. Inside of head

Frequency: Once every three months

Apply grease to the moving parts of the head, using grease specified by TAJIMA.

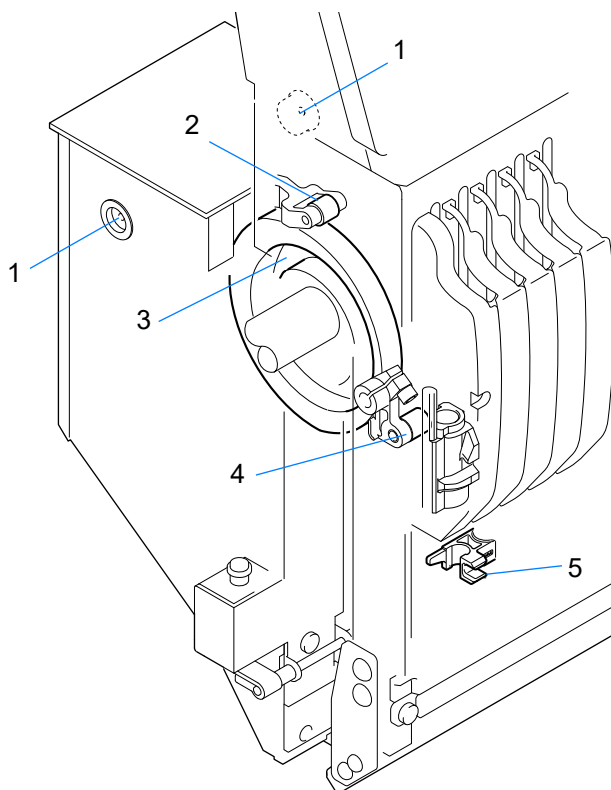

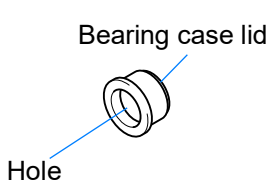
Greasing spot	
1	<p>Take-up lever shaft holder Inject grease from the hole in the bearing case lid, using a syringe.</p> 
2	Take-up lever roller
3	Take-up lever cam
4	Jump roller
5	Presser foot reciprocator

5-3. Gear box

Frequency: Once every three months

Apply grease to the gears in the gear box, using grease specified by TAJIMA.

CAUTION

-  The coating on the gear surface may peel off and become black powder that mixes with the grease. In this case, wipe off the grease thoroughly before applying grease.

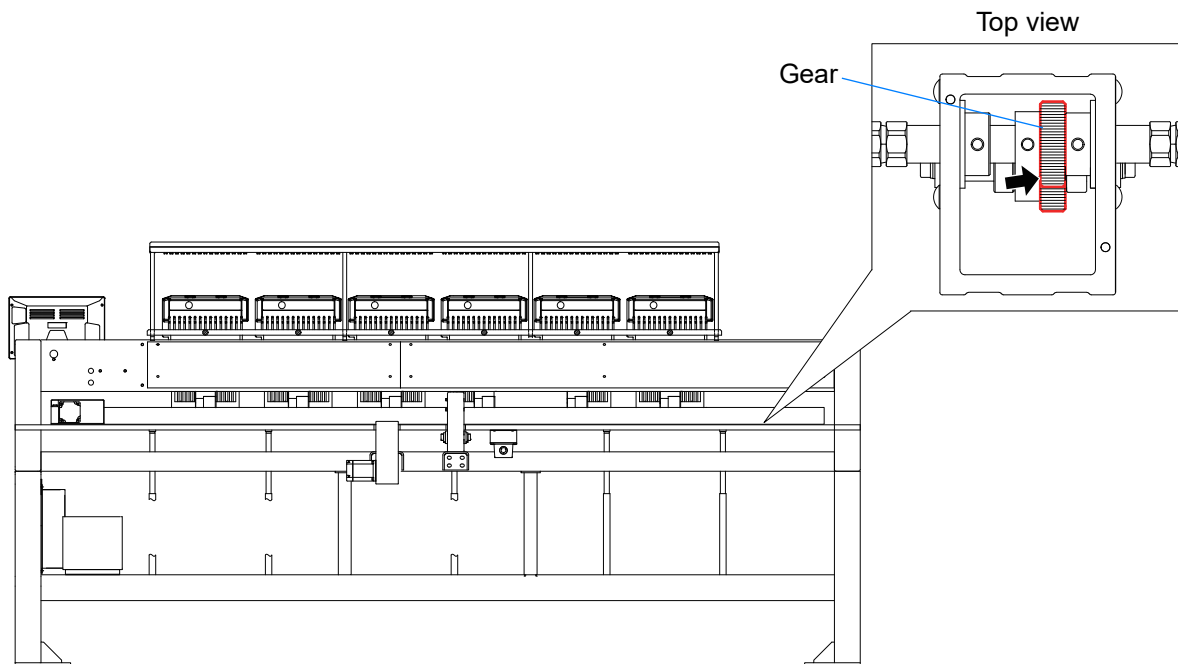

1

2

3

4

5

6

7

8

9

6. Inspection and Repair

This section contains information intended for use by service personnel assigned and trained by TAJIMA.

6-1. Inspection of drive systems and sliding parts

Frequency: Once every three months

! WARNING

! Inspection of drive systems must be performed by the distributor or the service personnel assigned and trained by TAJIMA.

⚠ Before the work, turn OFF the power and remove the power plug from the outlet. Some circuits are supplied with voltage even after you remove the power plug. Wait until they are completely discharged (for at least 4 minutes), and then start the work.

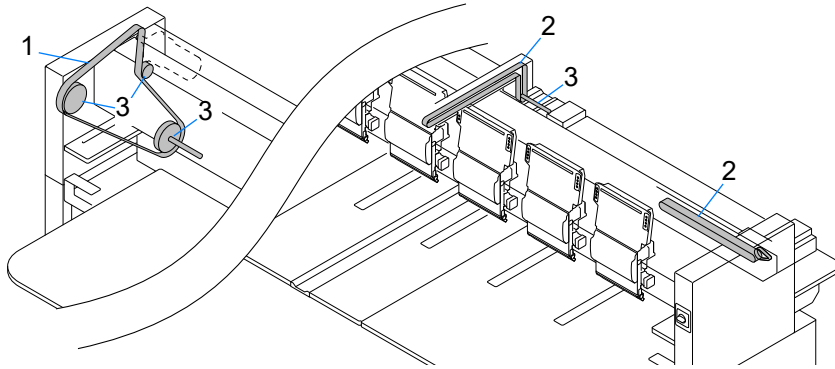

	Inspection point	Contents of inspection
1	Each belt in main shaft drive system	Tension of belt, degree of wear, existence of crack
2	X- and Y-axis drive belts	Tension of belt, degree of wear, existence of crack
3	Rotating, sliding section	Degree of wear of shafts and bearings

6-2. Repair

! WARNING

! Repair of the machine must be performed by the distributor or the service personnel assigned and trained by TAJIMA.

⊘ Do not change the specification nor modify the parts of the machine without due consultation with TAJIMA. Such modification may risk the operational safety.

⚠ Before the work, turn OFF the power and remove the power plug from the outlet. Some circuits are supplied with voltage even after you remove the power plug. Wait until they are completely discharged (for at least 4 minutes), and then start the work.

! CAUTION

! For the machine repairs, use TAJIMA genuine parts for replacement.

7. Checking and Adjustment

This chapter describes how to check the height of the needle bar lower dead point and how to adjust the presser foot height.

WARNING

- ! Maintenance work should be performed by the personnel who is trained adequately.
- ! To prevent an accident due to an unexpected startup, be sure to turn off the power before accessing the machine.





CAUTION

- ! Take care to prevent the needle from sticking in your finger.

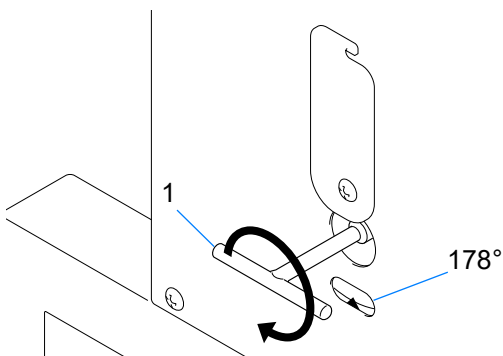
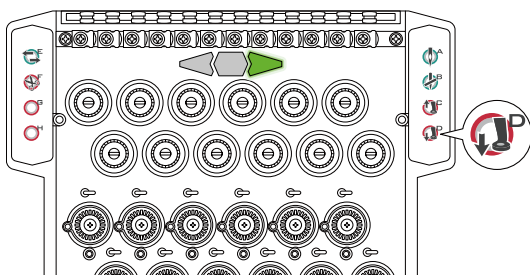
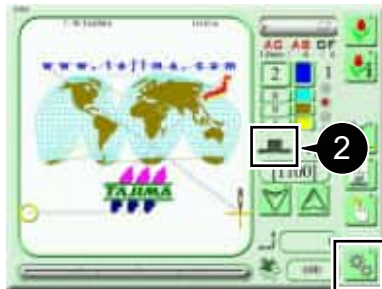
7-1. Checking the needle bar lower dead point

The machine is adjusted by default so that the needle bar reaches the lower dead point when the main shaft angle is 178°. If you often encounter problems such as the thread breakages or needle breakages or bad embroidery finish, the needle bar lower dead point may be incorrect. Check the condition using the supplied lower dead point gauge. The following example shows how to check the first needle bar.



- 1 Set the needle position to the first needle by operating the operation panel.
- 2 Hold down  (for at least 2 seconds).  blinks, and the main shaft brake is released. Hold down  again to set the main shaft brake.
- 3 Press  on the tension base twice to set the presser foot to the lower dead point.
- 4 Insert hexagon wrench 1 (M6) into the left-hand side of the machine and turn the hexagon wrench 1 counterclockwise to set the main shaft angle before 178° (the needle bar lower dead point).

7. Checking and Adjustment

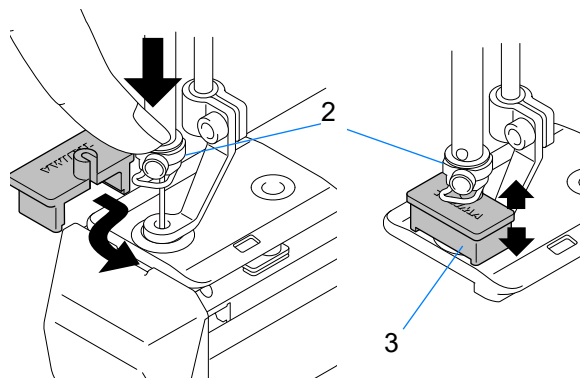

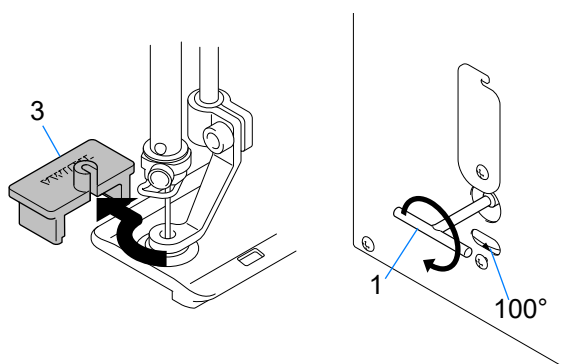

- 5 Lower the needle clamp 2 by finger and lower the needle bar.
- 6 Insert lower dead point gauge 3 under needle clamp 2 and turn hexagon wrench 1 slowly to 178°.
- 7 Check that the lower dead point gauge 3 has no play.

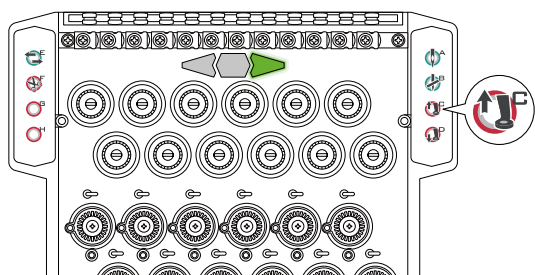

- 8 Turn hexagon wrench 1 a little clockwise to raise the needle bar and remove lower dead point gauge 3.
- 9 Turn hexagon wrench 1 clockwise to set the main shaft angle to 100° (the stop position).



- 10 Press  on the tension base to raise the presser foot.
- 11 Hold down  on the main screen to set the main shaft brake.

7-2. Adjusting the stroke amount of the thread take-up spring

When you want to tighten or loosen the thread tightening, adjust the stroke amount of the thread take-up spring inside the middle thread guide.

■ Removing the middle thread guide

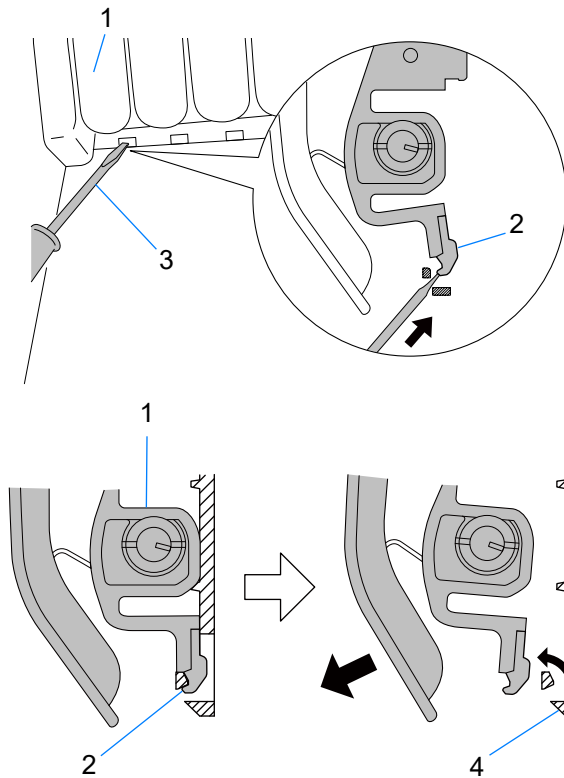

- 1 Remove the middle thread guide 1 from the top cover 4 by pushing its pawl 2 with something like a stick 3 with a sharp tip and pull it toward yourself.

1

2

3

4

5

6

7

8

9

■ Stroke amount adjustment

Adjust the thread take-up spring stroke amount by turning the spring shaft using a coin or the like inserted into its groove.

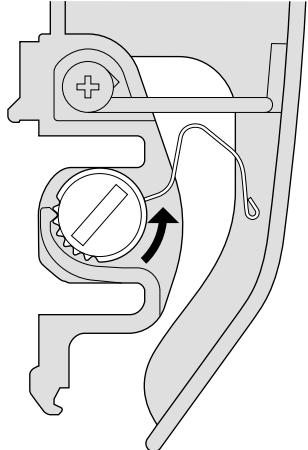
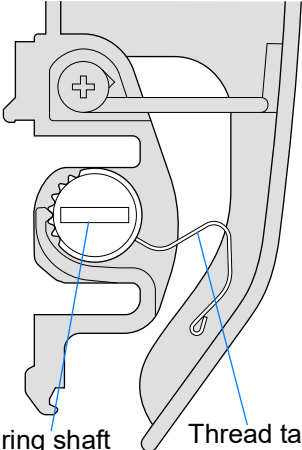
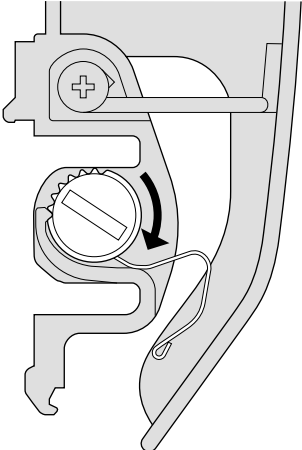
Thread tightening	Getting weak	Standard	Getting strong
Stroke	Minimum	Standard	Maximum
Maximum adjustment	Three levels in the counterclockwise direction	Position by factory default	Two levels in the clockwise direction
Condition		 Spring shaft groove Thread take-up spring	

■ Installing the middle thread guide

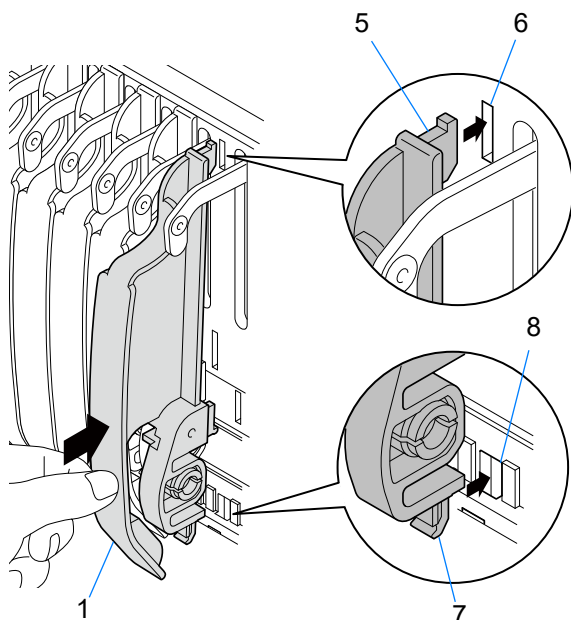

1. Insert the upper pawl 5 of the middle thread guide 1 into the slit 6 and fit the locking pawl 7 into the hole 8 by pushing it up by finger.
2. Push the middle thread guide 1 securely to fit until it clicks into place.

8. Others

This section contains information intended for use by service personnel assigned and trained by TAJIMA. After you remove the tension base cover for such purposes as replacing a card, fasten the harness with a coated clip and pull it out so that the mark tube is exposed outside from the grommet.

CAUTION

 When installing the tension base cover, pull out the harness. Otherwise, the harness may come into contact with the card inside, and the card may be damaged.

8-1. Precautions to take when installing the tension base cover

[Fasten with a coated clip]

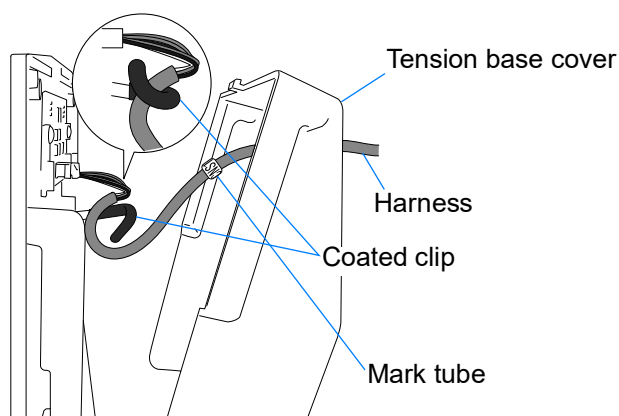

[Pull out the mark tube]

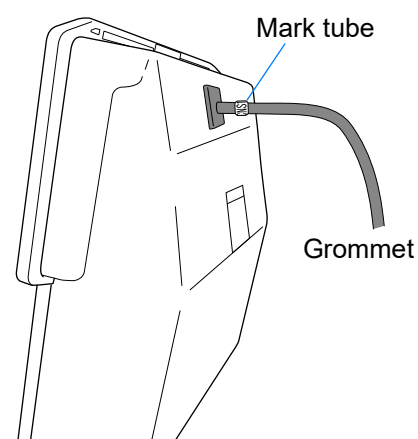

Chapter 8

Troubleshooting

1. Message Screen

When the machine stops during operation, a message screen appears on the operation panel. Perform troubleshooting based on the code No. and message displayed on the message screen.



Code	Stop factor	Corrective action
0D1-**	Buffer error	Turn OFF/ON the main power. Install the system software.
0D2	Panel communication parameter error	
0D3-**	Controller internal error	
1B1	Stop by frame stepping code After starting the zigzag cord device, the machine stopped because of a skip operation due to thread processing.	Continue the operation of the machine if needed after processing the thread.
1B2	Stop by color change code This stop is not caused by an error.	Perform "Start operation" or "Frame Back/ Forward operation" or press any operation key to continue the operation of the machine.
1B3	Stop by end code This stop is not caused by an error.	
1B4	Stop by thread trimming code This stop is not caused by an error.	
1B5	Stop by sequin code This stop is not caused by an error.	
1B6	Stop by automatic arbitrary offset code This stop is not caused by an error.	
1B8	Stop by temporary stop code This stop is not caused by an error.	Perform "Start operation" or "Frame Back/ Forward operation" or press any operation key to continue the operation of the machine.

Code	Stop factor	Corrective action
1C1	Stop by the stop button Machine stopped by the operator's operation.	Continue the operation of the machine if needed. Turning OFF the main power with the code 1C1 displayed on the message screen may render it impossible to continue embroidery.
1C3	Halt by input of external stop signal Machine stopped by the stop signal from an external device.	Continue the operation of the machine if needed.
1C4	Stop by switch operation of tension base The machine stopped because the tension base switch was switched from clutch to normal during a sequin color change/zigzag cord embroidery.	If necessary, perform "Start operation" to continue the embroidery.
1C5	Installation interrupted Software installation was interrupted by the operator's operation.	Retry after pressing the reset button.
1D1	Halt at Frame Back start point Machine stopped by the halt setting at the start point of embroidery for all heads after Frame Back operation.	Perform "Start operation" to continue the embroidery.
1D2	Preset Halt Machine stopped by the preset halt setting.	Reset the machine by pressing the reset button. Perform "Start operation" to continue the embroidery.
1D4	Temporary suspension due to data preparation	Wait until the "Processing" message disappears.
1D6	Board reset request received A reset request was sent while in operation.	Wait until the "Processing" message disappears.
211--01	Fixed position signal error Machine stopped at other than the fixed position.	Return the main shaft to the fixed position. Adjust the encoder/encoder Z signal.
211--02	Fixed position signal error Machine stopped, but the main shaft and needle were out of the fixed positions.	Return the main shaft and needle to the fixed positions. Adjust the encoder/encoder Z signal.
211--03	Fixed position signal error Machine stopped, but the main shaft was out of the fixed position while power was being restored.	Adjust the encoder/encoder Z signal. When the error code is cleared, frame origin search is performed after the main shaft automatically moves into the fixed position.
211--04	Fixed position signal error Due to improper encoder adjustments, the encoder Z signal cannot be detected even though the main shaft is in the fixed position.	Check the encoder. Adjust the encoder so that the mechanical fixed position and encoder Z signal are correctly synchronized.
212	In the state of needle bar lowered Needle bar is descending.	Move needle bar up and operate the machine.
213	Lower dead point error Machine is stopping at the lower dead point.	Move needle bar up and operate the machine.

Code	Stop factor	Corrective action
221	+X axis limit signal detection The embroidery frame moved to the travel limit position (left). (+X direction)	Move the frame manually to embroider within the setting of embroidery space.
222	-X axis limit signal detection The embroidery frame moved to the travel limit position (right). (-X direction)	Move the frame manually to embroider within the setting of embroidery space.
223	+Y axis limit signal detection The embroidery frame moved to the travel limit position (front). (+Y direction)	Move the frame manually to embroider within the setting of embroidery space.
224	-Y axis limit signal detection The embroidery frame moved to the travel limit position (rear). (-Y direction)	Move the frame manually to embroider within the setting of embroidery space.
225	Frame data embroidery range over With the current design start position, the design does not fit within the possible embroidering area.	Move the frame manually to embroider within the setting of embroidery space.
251	Lubrication level error Lubrication level is irregular.	Supply oil to the lubrication tank.
258	Upper dead point sensor error Upper dead point sensor error detected.	Check/Replace the upper dead point sensor of the color change sequin device.
259	Lower dead point sensor error Lower dead point sensor error detected.	Check/Replace the lower dead point sensor for the color change sequin device/zigzag cord device.
25A	Sequin color change sensor failure Color change sensor error detected.	Check/Replace the color change sensor for the color change sequin device.
291	Stop by detecting thread breakage Machine detected upper thread breakage.	Check the upper and under threads. Check or replace the tension base card.
293	Stop by detecting under thread breakage Machine detected under thread breakage.	Check the under thread. Check or replace the tension base card.
294	Running out of material detected Machine detected running out of sequin material.	Check/replace Sequin material.
2A1	Thread trimming position adjustment error Adjustment time of thread trimming position was exceeded.	Return the ATH movable knife to the fixed position. Check or replace the thread trimming motor or the thread trimming motor encoder.
2A3	ATH thread separation error	Set the tension base switch at the detected head to the top and make LED lit green. Then press the reset key on the operation panel or start by the bar switch.
2A4	ATH Skip stitch error	
2B2	Tajima data complement error Complement error has been detected in Tajima data.	The same number of + and - in the design data is valid at the same time. Correct the design data.

Code	Stop factor	Corrective action
2B3	Data found in end code Data is found in end code.	Delete "X/Y travel amount of the end code" of the design data.
2B4	Function code error Function code error occurred.	There is a function code that is not defined. Correct the design data.
2B7	Data set incomplete Data set is not completed.	Operate the machine after setting the data of embroidery design.
2B8	Frame Forward limit over Frame Forward exceeded available range.	The Frame Forward range beyond the current needle number is not possible.
2B9	Memory write error Cannot write data into memory.	Check and replace CPU card/operation panel.
2BA	Memory capacity exceeded Free space of memory is insufficient.	Increase the free space of memory by deleting unnecessary designs in the designs registered in the memory (after taking the backup if needed).
2BB	Frame Back limit over Frame Back exceeded available range.	The Frame Back range before the current needle number is not possible.
2BC	Design No. error Design No. is not found. Cannot edit the design because the data is being set. The design is not registered in the memory.	Set the data for the same or other design and then edit the desired design. Register the design in the memory.
2BE	Incorrect function code segment Start/end codes are not registered in a pair for the function which has start/end.	Modify/set the design again so that the codes of start/end become a pair.
2BF	Memory read error Memory cannot be read.	Check and replace CPU card/operation panel.
2C1	Insufficient program setting	Operate after coming out of parameter setting screen/the other setting screens/manual operation screen.
2C7	Password requested Password is required. The password you entered is not valid.	Input the password.
2CE	Stop by safety device Machine was stopped by the stop signal from the safety device.	After confirming safety, continue the operation of machine if needed.
2E2	Air pressure error Air pressure has become lower than the standard level.	Check/adjust the pressure of air supplying.
2E3	Power failure during operation The power supply was shut off during main shaft operation.	Turn ON the main power and perform the operation of power resume.

Code	Stop factor	Corrective action
311-**-	Encoder A signal error	Check the encoder/encoder signal lines. Check the main shaft driver for excitation.
312-**-	Encoder Z signal error	Check the encoder/encoder signal lines.
314-**-	Main shaft revolution error (super-load error)	After checking around the rotary hook and the main shaft motor, remove the factor that the main shaft cannot rotate.
316-**-	Main shaft motor error	Turn OFF/ON the main power.
319	Main shaft stoppage due to embroidery data reception failure Stitch data was not received during two revolutions of the main shaft.	Turn OFF/ON the main power. Check/Replace the main shaft motor/driver.
321-**-	Frame driver irregular signal	Decrease the number of the main shaft revolutions. Check/Replace the X- and Y-axis driver board/frame motor.
32C	X-axis frame movement incomplete	Turn OFF/ON the main power. Check/Replace the X-axis driver board.
32D	Y-axis frame movement incomplete	Turn OFF/ON the main power. Check/Replace the Y-axis driver board.
32E	X-axis origin search incomplete	Check the embroidery range setting. Check/Replace the sensor board.
32F	Y-axis origin search incomplete	
352	Sequin IV driver failure	Check/Replace the sequin IV board.
353	ESQ-C driver failure	Check/Replace the ESQ-C board.
354	Motor overcurrent	Turn OFF/ON the main power. Decrease the number of the main shaft revolutions. Check/Replace the head board.
361-**-	Jump Driver signal error	Turn OFF/ON the main power. Decrease the number of the main shaft revolutions. Check/Replace the head board.
376	Presser foot position error	Return the presser foot to the retracting position.
378-**-	Presser foot driver error	Turn OFF/ON the main power. Decrease the number of the main shaft revolutions. Check/Replace the head board.
379-**-	Hook driver error	Turn OFF/ON the main power. Check/Replace the hook motor/head board.
382-**-	Time to move to target position	Check/replace the color change motor/encoder and potentiometer (needle position sensor).

Code	Stop factor	Corrective action
383-**	Needle position error	Move the needle bar position into the setting range. Check or replace the potentiometer (needle position sensor) or the color change encoder.
384	One-turn signal is not detected	Check/replace the photo interrupter (1-rotation sensor) and color change encoder.
388-**	Color change driver error	Turn OFF/ON the main power. Check the changer. Check/Replace the controller board.
3A1-**	ATH Driver signal error	Turn OFF/ON the main power. Check/Replace the thread trimming motor/controller board.
3A2	ATH timeout	Check if the threads are biting. Turn OFF/ON the main power. Check/Replace the thread trimming motor/controller board.
3A3	Upper thread lock driver	Turn OFF/ON the main power. Check/Replace the head board.
3A6	ATH movable knife retracting position error	Check the position of ATH movable knife.
3B4	Communication error	Check/Replace the head board.
3B6	Communication error	Check/Replace the driver board.
3B8	Color change sequin error	Check/Replace the ESQ-C board.
3B9	Up-and-down color change driver communication error	
3BE-**	Network communication error	Check the network connection settings. Turn OFF/ON the machine and the connected devices such as DG/ML. Check the connection cable.
3C1	Start/Stop switch error	Check or replace the connector/connection terminal/limit switch. Turn OFF/ON the main power.
3C2-**	Frame travel key error	Check or replace the frame travel switch. Turn OFF/ON the main power.
3D1	Battery signal error	Charge/replace the battery of the operation panel.
3D4	ROM checksum abnormal	Turn OFF/ON the main power. Install the system software. Check/Replace the CPU board.
3D5	RAM checksum abnormal	
3D6	Watchdog error	
3D7	System RAM error	
3D8	CPU exception processing error	
3DA	Permanent Counter error	Check/replace the connection of permanent counter.

Code	Stop factor	Corrective action
3DB	System RAM capacity insufficiency	Turn OFF/ON the main power. Install the system software. Check/Replace the CPU board.
3DC	Storage error	
3DD-**	System installation error	After pressing the reset button, press the retry button and install again. Turn the main power back on and reinstall the software. Check/ Replace the CPU board.
3DE	External storage device error	Turn OFF/ON the main power. Check/Replace external storage media. Check/Replace the CPU board.
3DF	Storage failure	Turn OFF/ON the main power. Check/Replace the CPU board.
5B1	Design header information error	Replace the design data. Use the design data created by DG/ML.
5C1	Frame origin memory incomplete	Perform absolute origin search.
5C2	Sequin in operation	Do not operate the machine while the sequin device is moving up or down.
5C3	Color change sequin setting error	Check/change the parameter setting of sequin device on operation panel.
5C6	General external device is operating.	Do not operate the machine during the operation of general external device.
6B1	Communication error	Check/Replace the sequin IV board.
6B2	Communication error	Check/Replace the main shaft driver board.
6B3-**	Logger communication error	Turn OFF/ON the main power. Check/Replace the logger board.
6B5-**	Communication error	Turn OFF/ON the main power. Install the system software. Check or replace the related cards.
6D1	Frame parameter file error	Install the system software.
6D2	Communication line not connected	Turn OFF/ON the main power. Check each harness connection. Install the system software.
6D3	Communication error	
6D4	SHT connection error	Connect the harness for SHT control.
6D5	Power failure detection device connection error	Connect the harness for power failure detection.
OIL	Preset Halt Machine stopped by the preset halt (Lubrication) setting.	After lubricating the necessary spots, reset the machine by pressing the reset button. Perform "Start operation" to continue the embroidery.
B01	Formatting error The memory media is formatted incorrectly. Cannot read or write the data.	After taking the backup, format the memory media. Use new memory media.

Code	Stop factor	Corrective action
B02	Disk FAT error There is an error in management information on the storage media.	Back up storage media and do not use error-prone storage media.
B03	Write protect error The memory media is write-protected.	After cancelling the write-protection for memory media, perform the writing operation.
B04	Empty media error Media is not inserted.	Insert memory media.
BC1	Unregistered design No. Design No. is not found.	Perform the selection of design again.
BC2	Design file name double registration error There is a design with the same file name on the storage media.	Rename the file.
BC3	Disk file error This memory media cannot be read.	After taking the backup, format the memory media. Use new memory media.
BC4	Verify error Abnormal Stitch Data found on Media.	Perform writing again.
BC5	Memory capacity insufficient error	Replace with a memory media with enough remaining capacity. Then press the reset button to continue the operation.

2. When the Machine Does not Sew Well

If the machine does not sew well, investigate the cause with reference to the following.

If the cause is unknown or the problem recurs, consult the distributor.

2-1. Frequent thread breakages

Cause	Troubleshooting
Improper thread tension	Adjust the friction. Upper thread = 120 to 140 g, under thread = 20 to 30 g
Poor thread flow	Use silicone.
Direction of needle is bad or needle bents.	Adjust to face to the front or to the right a bit. Replace the needle.
Applique glue is stuck on needle.	Remove adhered glue.
Lint, run-out of oil of rotary hook	Clean and lubricate.
Numerous tiny stitches of 0.5 mm or less in the design	Remove tiny stitch(es).
The fabric is lifted too much against the needle plate. The fabric touches the needle plate too much.	Replace the clips. Stretch the fabric again so that it touches needle plate lightly.
Run-out of oil of needle bar	Lubricate.
There is a scratch on the thread course and /or rotary hook.	Grind a scratch with sandpaper etc. Replace the rotary hook or the thread course.
Bad height of presser foot	Perform adjustment so that height fits to fabric/material.
The combination of frame drive timing and embroidery condition is inappropriate.	Change setting.

2-2. Needle breaks

Cause	Troubleshooting
Improper thread tension	Adjust the friction. Upper thread = 120 to 140 g, under thread = 20 to 30 g
Density of design data is very high	Correct design data. Delete unnecessary underlay stitching.
The material is too thick or hard.	Use material suitable for embroidery.
Bobbin is deformed and the needle touches it.	Replace the bobbin.
Deterioration of needle, mis-matching to embroidery condition	Replace the needle. Use needle that fits to condition.
Vibration of the machine is big.	Center support is applied too much. Tighten the support by hand. Adjust leveling.
The combination of frame drive timing and embroidery condition is inappropriate.	Change setting.

2-3. Embroidery results not good

Cause	Troubleshooting
Improper thread tension	Adjust the friction. Upper thread = 120 to 140 g, under thread = 20 to 30 g
Poor thread flow	Use silicone.
Density of design data does not match with material and/or thread.	Correct design data.
Bad frame attaching and fixing of the fabric	Attach the frame correctly. Fix the fabric firmly.
The combination of thread, needle and/or the size of needle plate is inappropriate to the embroidery condition.	Make combination that fits to design/material.
R.P.M. is too high.	Decrease R.P.M.
The combination of frame drive timing and embroidery condition is inappropriate.	Change setting.

3. Power Resume after Power Failure

If the power is shut down due to power failure or emergency stop during embroidery, turn ON the power and perform power resume.

CAUTION

 Do not put your hand on the table when you operate the machine. The needle bar or frame moves and may cause injury to your fingers and hand.



1 Press  on the message screen.

The power resume method selection screen appears.

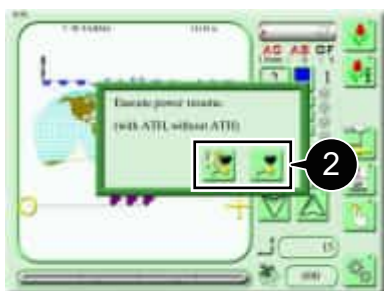

2 Select the power resume method.



: Perform power resume after trimming the thread.



: Perform power resume without trimming the thread.





- When you perform power resume, the machine checks the absolute origin and the frame moves to a position several stitches back from the position where it was when the power was turned OFF.

4. Obtaining Log Data

Machine operation history and communication history are recorded as machine logs.

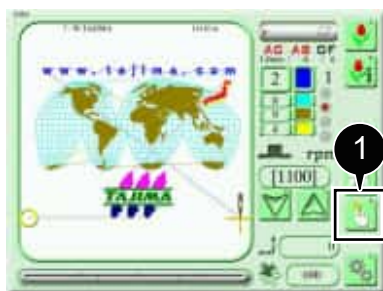
If the distributor requests you to provide log data for the purpose of investigating the cause of trouble, save the log data in a USB memory.



- 1 Insert the USB memory into the USB port of the operation panel and then press  on the main screen.

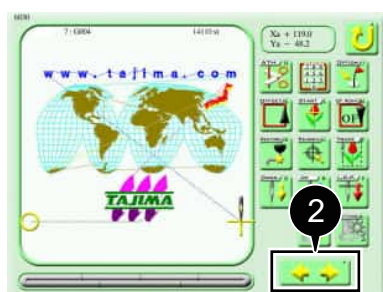

- 2 Press .



- 3 Press .



- 4 Press .

The log data saved on the CFast card in the operation panel and the log data you have obtained will be saved on the USB memory.



- When  pressed, the log information will be saved up to 50 times on the CFast card in the operation panel; if the number of times exceeds 50, the log information will be overwritten.

- 5 Remove the USB memory from the USB port.

Chapter 9

Appendix

1. Improving the Sewing Finish Quality (FS Mode)

FS mode improves the finish of sewing even if you use badly passing thread (the metallic thread, the thick thread) or soft-twisted thread.

This function is especially effective for the embroidery using soft-twisted thread that was improper for the embroidery machine.



- You can configure FS mode with a parameter. For details, refer to the separate "Parameter Settings" manual.

1-1. Outline of function

■ Improvements by FS mode

- Decrease of thread breakage (Metallic thread)
- Improvement of thread tightening for satin stitch (Soft-twisted thread, thick thread)
- Stabilization of satin stitch (Soft-twisted thread)
- The balance between the upper thread and the under thread is stable on the back of the fabric. (All thread types)
- Decrease of bad thread tightening points of the emblem embroidery (Polyester yarn)



- The above information is not applicable to all embroidery conditions. No improvement may be gained under certain embroidery conditions.

■ Movement of the machine in FS mode

FS mode is the function giving priority to the embroidery quality. Therefore, the productivity may lower under the following conditions.

Use it after understanding the following.

- Maximum RPM should be limited.

1-2. Sewing comparison

■ Sewing comparison by the difference between standard mode and FS mode

Thread type: Rayon 300 d/1

FS mode



Standard mode



■ Sewing comparison by the difference of threads

The following sewing samples (A, B, and C) were embroidered in FS mode. Even if you use a soft-twisted thread, you can perform embroidery as shown in samples A and B.



- If samples A and B (especially A) are embroidered in standard mode, problems such as fluffing and looping could occur.

Soft-twisted thread
(Rayon 300 d/1)



Thread twisted a little softer
(Middle level of twist between A and C)
(Polyester 120 d/2)



Normal embroidery thread
(Rayon 120 d/2)



1-3. Making use of optional parts

We prepare optional parts to improve the embroidery finish.

Consult your TAJIMA distributor to select optional parts that best suit the threads you plan to use and your fabric embroidery conditions.

■ Examples of using optional parts

Embroidery conditions	Optional parts
In case of using metallic thread	Thread guide and snarl prevention
In case of using the thick thread	Dedicated needle plates
In case of using soft-twisted thread	Thread guides and dedicated needles

Optional parts may not be applicable to your conditions, depending on the threads, designs, and fabric you use.



- Thread guides, dedicated needles and needle plates are not set products.
- As a sample items, thread guides and needles for 2 needles come with the machine.

■ Thread guide

In case of using badly passing thread, the upper thread tension will be too tight. Therefore, detach the spiral tube, and attach this thread guide.

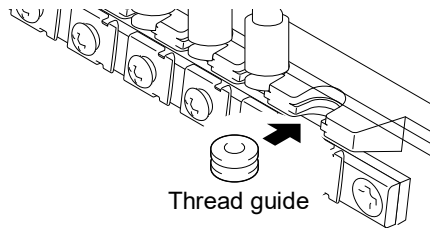

Part name	Part No.
Thread guide: 2.2 MM DIA.	516501040000



- When the color change having large slide volume is performed, the thread tangle sometimes occurs.

■ Dedicated needle plates

The hole diameter is larger for thicker threads.

Part name	Part No.
Needle plate: 2.5 MM DIA.	050340551010

■ Dedicated needles

Needles developed specially for FS mode. They are effective for soft-twisted threads that would otherwise be conventionally difficult to embroider.

Part name	Part No.
Needle: DB-K5Z1 FS #11 U	616500570000
Needle: DB-K5Z1 FS #11 Y	616500580000
Needle: DB-K5Z1 FS #14 U	616500590000
Needle: DB-K5Z1 FS #14 Y	616500600000



- Not suitable for the fabric that requires strong force that the needle penetrates through.

■ Snarl prevention

Prevents snarling (tangling of threads) that occurs when consuming thread by embroidery.

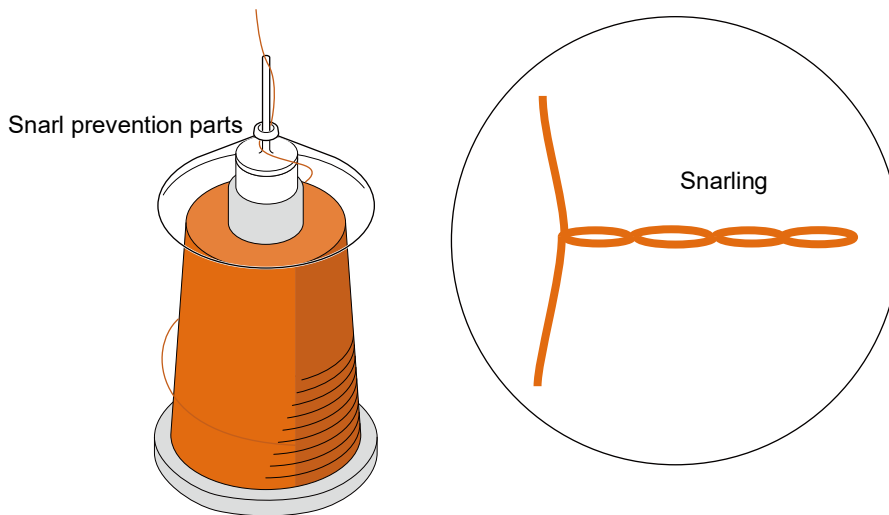

Part name	Part No.
Snarl prevention parts	911400100T00

2. Upgrading the Software Version

The latest software is installed in this machine at the shipment. When it is necessary to upgrade the software later, install the updated software.

Regarding the contents and how to obtain the latest software, please consult the distributor.



- This operation requires input of the password. After you enter the password, you can perform the following operations until you turn off and back on the power. For details, consult the distributor.

■ Explanation on the screen

Current version No.

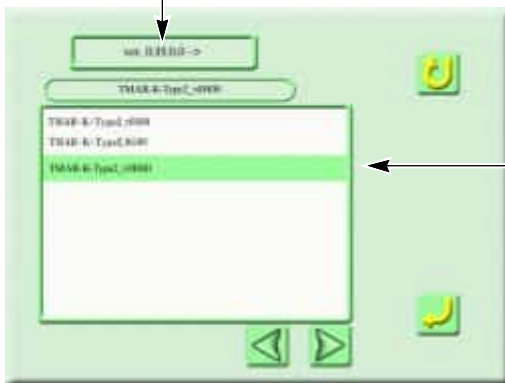

When different software versions reside in the USB memory, the display as the left figure will appear. You can select and install your desired software.

■ How to operate

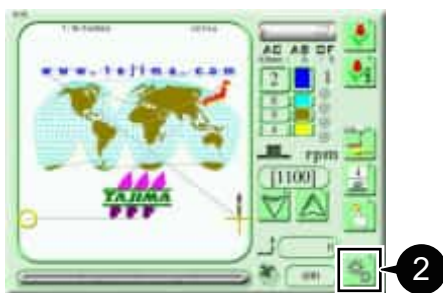

1 Insert a USB memory containing software into the USB port on the operation panel.

2 Press  on the main screen.



3 Press  twice.



4 Press 



5 Input a password.

6 Press 



7 Press 

8 Press 



9 Press 



10 Select "85. Machine adjustment".

11 Press 

1
2
3
4
5
6
7
8
9

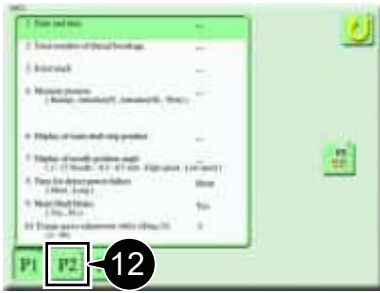

12 Press .



13 Select "15. Software install".



• If the software installation is not displayed, refer to "Display/hide each parameter item" in the separate "Parameter Setting" manual.

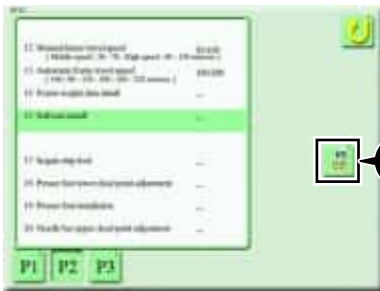

14 Press .



15 Press .

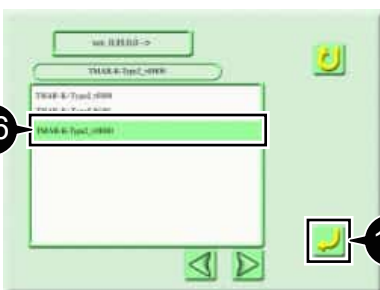

16 Select your desired software.

17 Press .

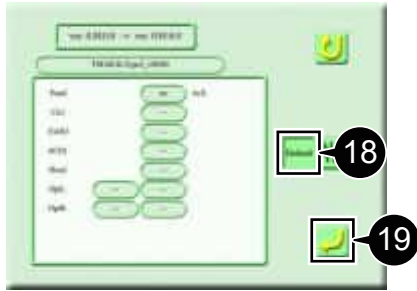

18 Select the installation method.

Default : Install only the necessary system

ALL Yes : Install all the systems



- To overwrite the same software, select

ALL Yes

19 Press .

The software is installed.



20 When the completion screen appears, remove the USB memory from the USB port of the operation panel.

21 Turn ON the power again.



- To turn ON the power again, wait for 30 seconds or more. Otherwise the system may fail to start up normally.

1

2

3

4

5

6

7

8

9

3. Specifications

3-1. Electrical specifications

Allowable voltage range	Within $\pm 10\%$ of the rated voltage
Frequency	50/60 Hz
Apparent power	TMAR-KC TYPE-2 2- to 6-head machine: 740 VA (max.) 8-head machine: 900 VA (max.) TMAR-VC 12-head machine: 900 VA (max.)
Active power	TMAR-KC TYPE-2 2- to 6-head machine: 530 W (max.) 8-head machine: 680 W (max.) TMAR-VC 12-head machine: 700 W (max.)
Insulated resistance	10 M Ω or greater (500 megger insulation tester)

3-2. Ambient noise level

The ambient noise level of the machine is less than 85 dB. Measuring conditions are as follows.

Measuring ambience	Refer to the right illustration.
Measuring position	Measured at position A at a height of 1.6 m from the floor and a distance of 1.5 m from the needle locating position
Working machine condition	Fabric is stretched on the border frame, and embroidered a design which has 4 mm width.
R.P.M.	Maximum number of revolutions of machine
Measuring instrument	Compliant to IEC61672-1: 2002 Class 1

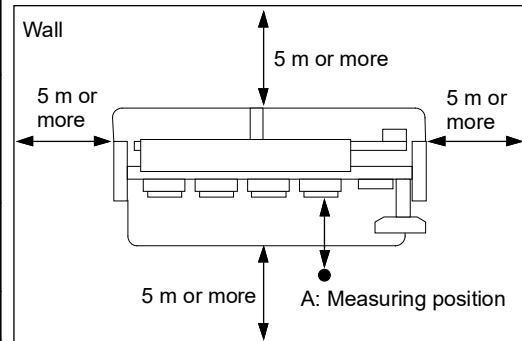

3-3. Machine weight

Machine weight is described on the spec. plate.

4. Terminology

The following terms are common to all the models. They may not apply to some models.

<A>

Absolute origin

An anchoring point to calculate the current frame position (Xa + 0.0, Ya + 0.0).

ATH

The abbreviation of Automatic Thread Trimming and Holding Device.

Auto jump

To make a stitch divided into two stitches as less than setting value automatically when its stitch length exceeds the setting value. It is effective to prevent the slippage of the frame and the displacement of the design.

Backlash

A play (gap) generated at the drive system and/or around the frame by shock when a stitch returns (when frame drive is reversed). It may affect embroidery finish.

<C>

Cleanup

To remove tiny stitches included in design data to make before and after stitches absorb it. It has an effect on decreasing thread breakages.

Condition data (CT0)

Embroidery condition included in the design (needle bar selection, data conversion, repeat, start position, automatic offset).

CT0

File including the information of needle bar selection and start position. It is necessary to handle TBF, CT0, and DGF as a set on a personal computer.

<D>

Data mode

Saving format of design (T, T2, T3).

Data set

To set the design data in the memory of the machine to start the machine.

D-axis

Driving shaft to rotate sewing needle and nipple (TCMX series).

DG by Pulse

Embroidery design creation software developed by Pulse Microsystems Ltd. It provides the ability to quickly convert vector data to stitches. It also provides the ability to send designs to the machine by connecting DG by Pulse to the machine via LAN.

DGF

File that indicates design image. It is necessary to handle TBF, CT0, and DGF as a set on a personal computer.

Driver

Control card to make the frame or main shaft drive. X-axis driver, Y-axis driver, main shaft driver, etc. are included.

DST

Stitch data for Tajima ternary format. Data saving format is T.

<E>

Excitation

To keep frame motor drive. It is not possible to move the frame by hand during excitation.

<F>

Fine stitch

Fine stitch as a factor causing thread breakage.
Stitch of which the stitch length is 0.5 mm or less.

Fixed pitch movement

Horizontal frame travel to the neighboring head by head interval.

Fixed position

Angle of the main shaft at which the main shaft motor stops (stop position).

Frame Back

To move the embroidery frame only to the direction where the stitches return with the needle bar(s) stopped.

Frame coordinates

Frame position in embroidery space. It is indicated like "X: -153.2, Y: +120.4".

Frame Forward

To move the embroidery frame only to the direction where the stitches advance with the needle bar(s) stopped.

Frame Limit

Limit position that the frame can move (it is indicated by mark-off line on the table).

Frame stepping

To move the embroidery frame only with the main shaft of the machine is stopped during embroidery.

Function Code

Command code that controls general movements of the machine. All design data consists of function codes (Stitch, Jump, Color, etc.).

<H>

Head group

Function that assumes multiple heads as one head by grouping them. This enables large design embroidery or multi-color embroidery with more colors than the number of needles per head.

<I>

Inching

Movement to stabilize start of sewing by moving needle bar slowly before the main shaft enters normal operation. It is also executed before thread trimming to stabilize thread trimming.

<J>

Jump

To make only the frame move in the state that needle bar does not move down during operation. It is possible to make a longer stitch than one stitch of the maximum length.

<M>

Main shaft brake

To hold the main shaft with the brake of the main shaft motor so that the main shaft does not rotate when it stops.

M-axis

Drive shaft to rotate nipple and bobbin (TLMX series).

<O>

Offset start position (Offset position)

Frame travel start position that is configured by operating the Automatic Offset. The position to make the frame stand by to facilitate changing of frame and/or fabric by moving the frame to the front automatically in the middle of sewing or at the end of sewing.

<P>**Parameter**

Setting items that decide the working condition of the machine.

Pseudo-fixed position (stop at the lower dead point)

The machine should be stopped with the needle stuck in the cloth at the end of embroidery. Moving the frame in this condition will enable consecutive embroidery.

<R>**Return stitches**

Tie stitch to be executed at start of sewing (stitch to prevent mis-stitching at start.).

Running stitch

Decorative stitch of straight line or curved line only.

<S>**Satin Stitch**

Repeated zigzag stitches. It is mainly used for hem of applique, logo, mark, flower design, etc.

Seed beads needle

Needle that embroiders with beads by seed beads device. It indicates the first needle or the last needle.

Sequin needle

Needle that embroiders with sequins by sequin device. It indicates the first needle or the last needle.

Step

The section divided by a color change code in the design. The first section is called Step 1 and the next section is called Step 2.

<T>**Table offset**

To move the frame to the rear direction temporarily to facilitate threading. It is mainly effective when the frame is positioned at the table cut section.

Tatami stitch

Stitches to fill in a certain amount of area. They are mainly used for a big logo, background, underlay etc.

TBF

Stitch data for Tajima binary format. Data saving format is T2. It can support more function codes than DST. It is necessary to handle TBF, CT0, and DGF as a set on a personal computer.

TCF

Data that integrates TBF, CT0, and DGF. Integration facilitates handling of designs. Data saving format is T3.

Tie stitches

Tie stitch to be executed before thread trimming (stitch to prevent fray).

<X>**X-axis drive system**

Drive system to make the embroidery frame move in the horizontal (X) direction.

X data

The data that makes the embroidery frame move right/left direction (X direction). It is indicated by moving direction (code: +/-) and the value (mm).

<Y>**Y-axis drive system**

Drive system to make the embroidery frame move in the vertical (Y) direction.

Y data

The data that makes the embroidery frame move front/rear direction (Y direction). It is indicated by moving direction (code: +/-) and the value (mm).

<Z>**Z-axis**

Drive shaft to change needle height (TCMX series).

1st edition
2nd edition

April 2023
September 2025

■ **Manufactured by:**
TISM Co.,Ltd.

Address : NO.1800, Ushiyama-cho, Kasugai, Aichi-pref., 486-0901, Japan
TEL : 81-568-33-1161 Fax : 81-568-33-1191

■ **Distributed by:**
Tajima Industries Ltd.

Address : NO.1800, Ushiyama-cho, Kasugai, Aichi-pref., 486-0901, Japan
TEL : 81-568-37-1130 Fax : 81-568-37-1230

●Copy, reprint, or reform of a part or whole of this manual without permission is prohibited.