

USER'S MANUAL

i-TM

TMCR



Foreword

This user's manual describes about the correct using method and instructions for use of this product. Please use this machine after understanding the contents of the manual.

This manual may contain discrepancies in detailed specifications as compared with the actual production model. If you have any questions about this manual, consult your TAJIMA distributor.

We believe that "BASICS TAJIMA EMBROIDERY MACHINES" and "MACHINE SETUP INSTRUCTIONS" are useful to deepen your knowledge about this product. Please also read those booklets.

Regarding how to handle the products related, refer to the user's manual exclusive for them included in the manual CD.

TISM Co.,Ltd.

SAFETY PRECAUTIONS

To prevent any harm or damage to the person who use this product or other person, we describe items that must be surely followed as below.



Indicates that there is a lot of danger of death or serious injuries [*1] if handled by mistake.



Indicates that there is a likelihood of death or serious injuries [*1] if handled by mistake.





Indicates a potentially hazardous situation which may result in minor or moderate injury [*2] or property damage if handled by mistake.

*1: A condition caused by electric shock, injury, fracture of a bone, etc., that leads to aftereffects, or an injury that necessitates hospitalization or visits to a hospital over a long period.

*2: An injury that does not necessitate hospitalization or visit to a hospital over a long period.

: Prohibited items

: Items that may cause electric shock if not observed

: Items that must be followed carefully to ensure safe operation

1. Outline of functions	1
1-1. Tension base	1
1-2. Operation panel	1
1-3. Step (Tension step)	2
1-4. Features of i-TM	2
2. Preparation	3
2-1. Threading.....	3
2-2. Upper thread lock	3
2-3. Under thread tension	3
3. Operation	4
3-1. Setting.....	4
3-2. Adjustment during operation.....	5
3-3. Saving Pattern No. with a name	6
3-4. Overwriting of Pattern No.	7
3-5. Reset of Pattern No.	7
3-6. All reset of Pattern No.....	8
3-7. Dividing of Step.....	8
3-8. Setting of the divided step	10
3-9. Deletion of the divided step	11
3-10. List of Pattern No.	11
3-11. Search by a name.....	12
3-12. Clearing of Pattern.....	12
3-13. Change of the name	13
3-14. Detailed setting	14
4. Parameter setting	15
4-1. Initial setting value	15
4-2. Thread trim length adjustment.....	16
4-3. Realtime QC	16
4-4. When using boring device	16
5. Electrical system diagram	17

1. Outline of functions

1-1. Tension base

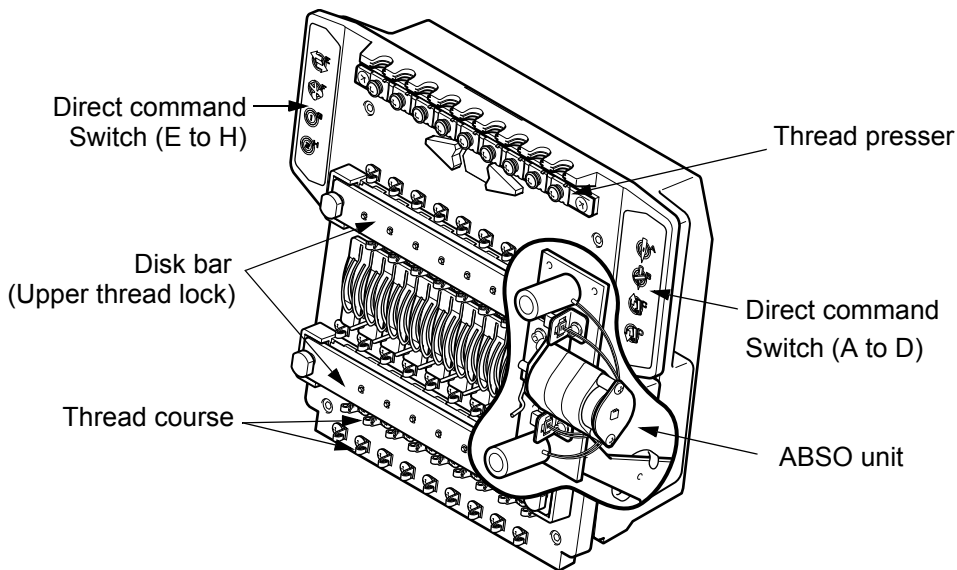

1-2. Operation panel

CAUTION

- Do not use the design data of which Tension Step has 1001 or more.
- If the error (6B5) is displayed, please contact the distributor.

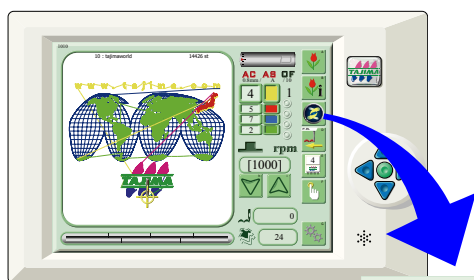

Select the step to be adjusted. 1-1 is 1 of the 1st tension step. And the pattern No. is increased as 1-1, 1-2 by dividing this step.

Dividing and deleting of Step

Initializing all pattern Nos.

Overwriting of Pattern No.

Saving Pattern No. with a name

Selected step flashes

10:tajimaworld
14426st

STEP

1	1
2	1

Thickness (0.0 - 8.0) 0.3 mm

Satin (-20 - +20) 0

Run (-20 - +20) 0

Pattern Number D1900000_N01

To return to screen 1010

Switching to Check screen

Setting of fabric thickness

Satin stitch setting

Running stitch setting

Selected pattern No., Selection of pattern No.

To decide the setting value

List of Pattern No., Edit

Reset of Pattern No.

1-3. Step (Tension step)

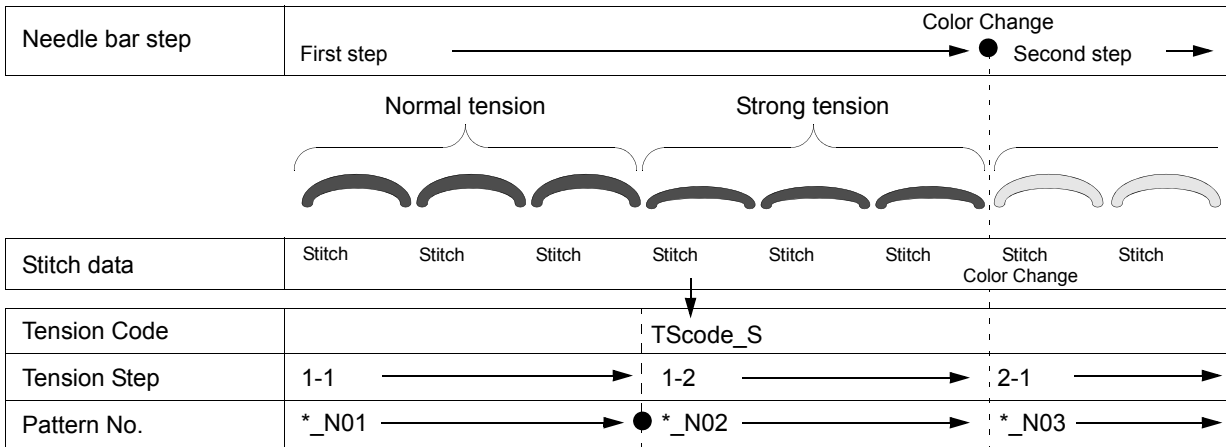

Tension Step exists in the unit of color change as well as the needle bar step. The upper thread tension can be set for each pattern No.
 Pattern No. can be allocated for each tension step. One tension step is allocated to one needle bar step, but tension step can be divided into multiple steps. Changing pattern No. in the same needle bar step can change the texture of the embroidery.

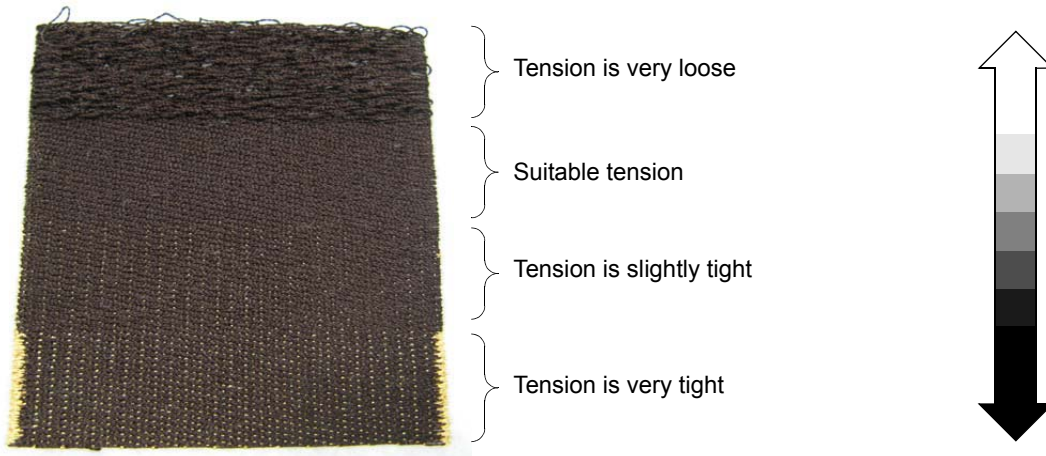

⚠ Mis-detection of thread breakage may occur if the setting value is extremely large (or small).

1-4. Features of i-TM

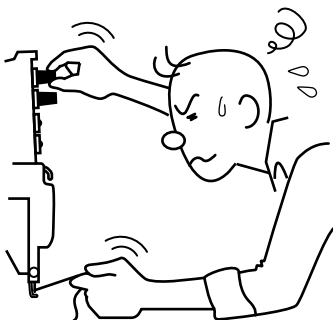

It is not necessary to adjust the tension of each thread because i-TM controls the tension of upper thread automatically when embroidering. Therefore time of the adjustment and the trial stitches can be saved.
 Thread tension can be set for needle bars of all heads. Also thread tension can be set and saved for a design. Therefore, it is possible to represent the same embroidery texture even if the operator is changed.

📖 By adjusting the under thread tension of all heads evenly, i-TM can be used more effectively.

2. Preparation

2-1. Threading

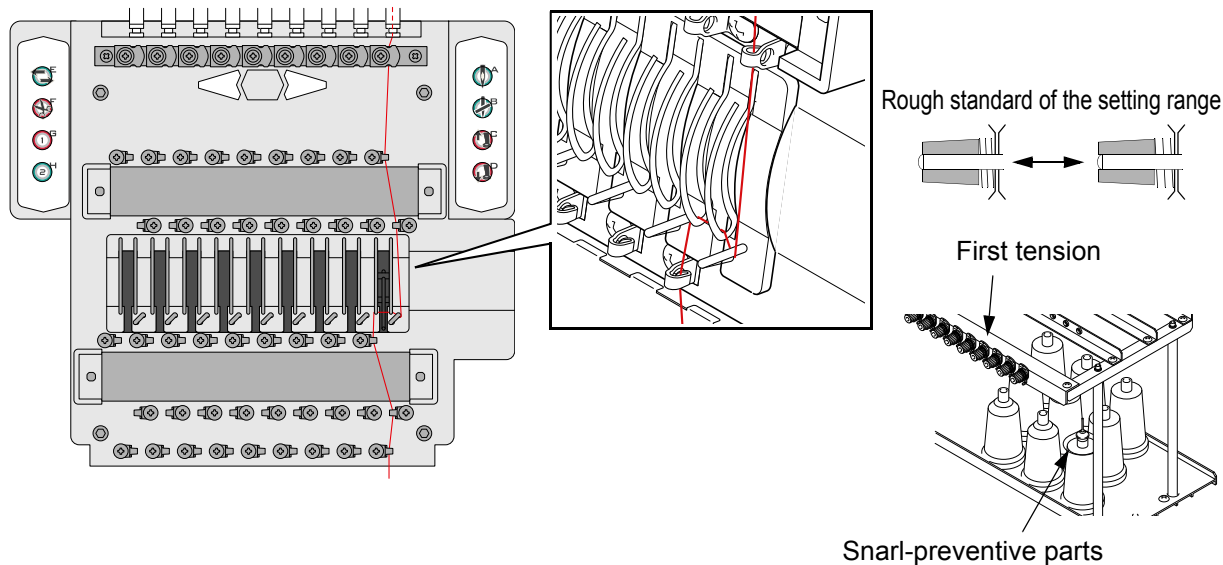

☞ When resistance is high by pulling thread, loosen the first tension. At that time, when being concerned about a snarl, use snarl-preventive parts.

2-2. Upper thread lock

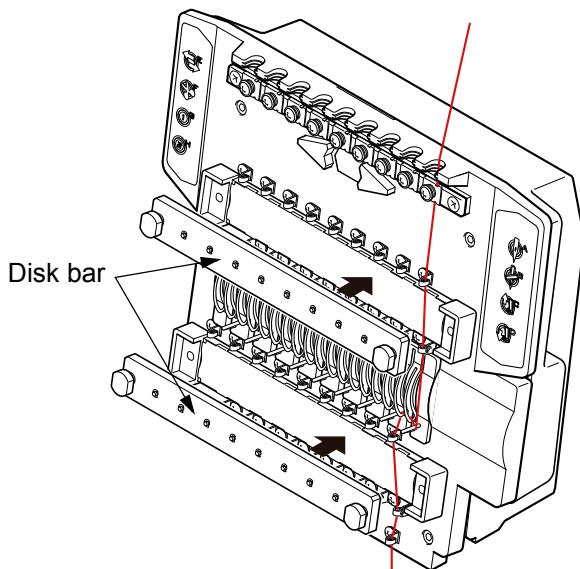

☞ There is no problem even if the disk bar is replaced between upper and lower, or right and left.

2-3. Under thread tension



Bobbin case thread tension gauge (BTG)

Align the tension of all the bobbin case to adjust the under thread tension of all heads evenly.

☞ By adjusting the under thread tension of all heads evenly, i-TM can be used more effectively.

3. Operation

3-1. Setting

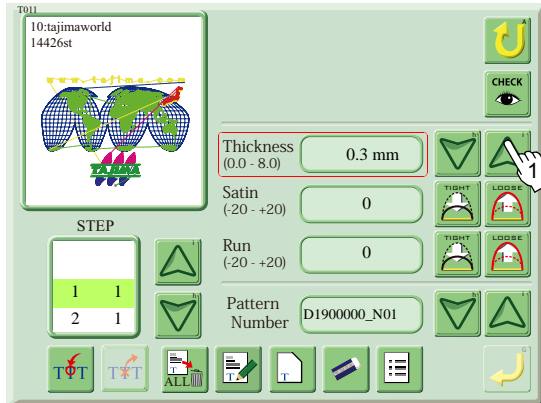

(1) Set the fabric thickness.

- Setting range of 0.0 to 8.0 mm
- The initial setting is 0.3mm

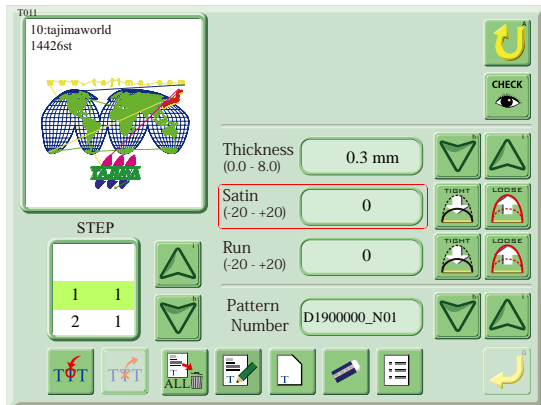

(2) Set the tension of satin stitch.

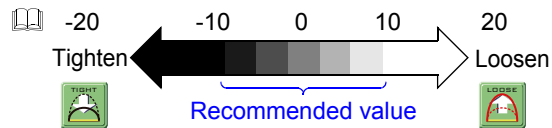

Setting range: -20 to 20, Recommended value: -10 to 10
The initial setting is "0".

- When mis-detection of thread breakage occurs by extremely increasing (or decreasing) the setting value, lower the detection sensitivity.

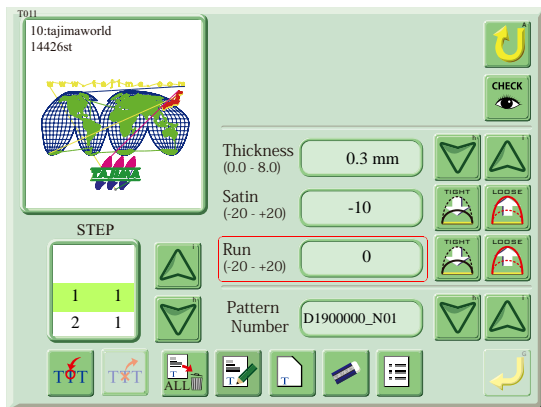

(3) Set the tension of the running stitch.

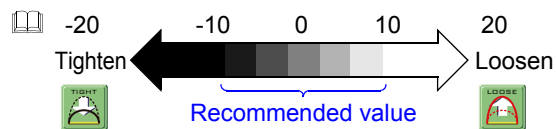

Setting range: -20 to 20, Recommended value: -10 to 10
The initial setting value is "0".

- When mis-detection of thread breakage occurs by extremely increasing (or decreasing) the setting value, lower the detection sensitivity.

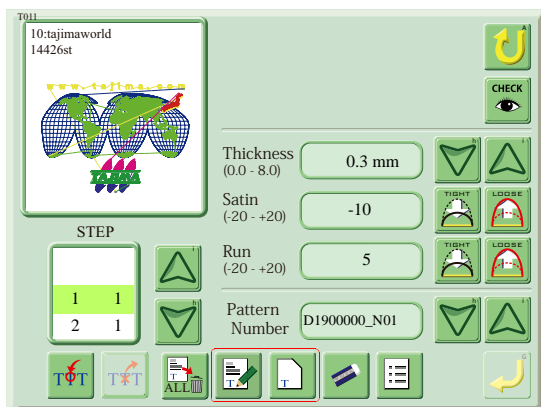

The setting value is confirmed by "overwriting" or "saving with a name" of the pattern No.

- Overwriting (p.7)
- Saving with a name (p.6)

Operation

3-2. Adjustment during operation

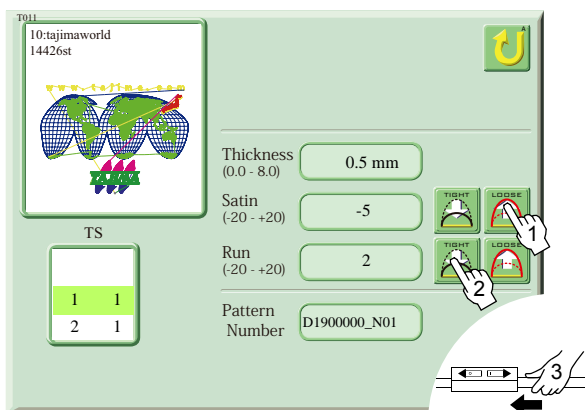

Check the tension of satin stitch and running stitch watching the tightness condition of thread during the operation of machine.

The items which can be changed during the operation of machine are only adjustment of satin stitch and running stitch.

- (1) Change the tension of satin stitch.
- (2) Change the tension of running stitch.
- (3) Stop the machine, and check stitches.

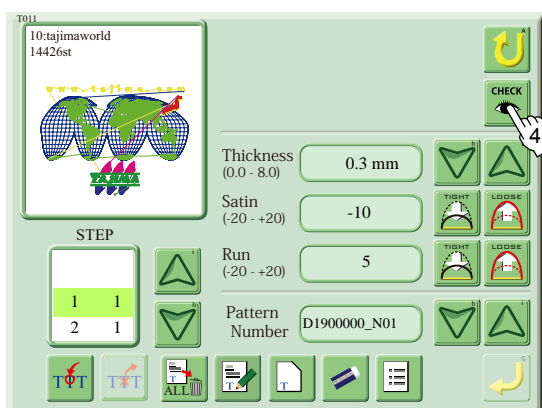

When stopping the machine, the value being adjusted will return to the value before change.

If the pattern No. is changed during the operation of machine, the value being adjusted will be cleared.

- (4) When pressing Check button, the value being adjusted will be displayed.

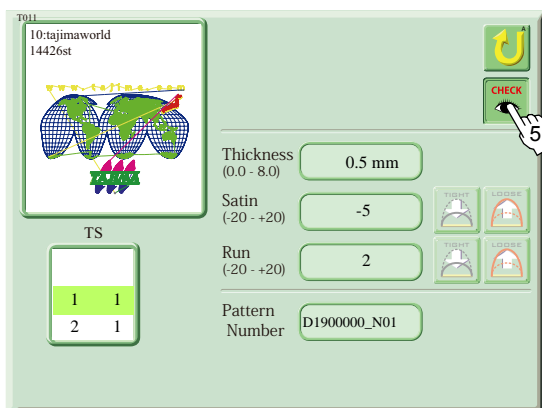

The value adjusted during the operation of machine will be displayed.

- (5) Pressing the check button again will return to the previous screen.

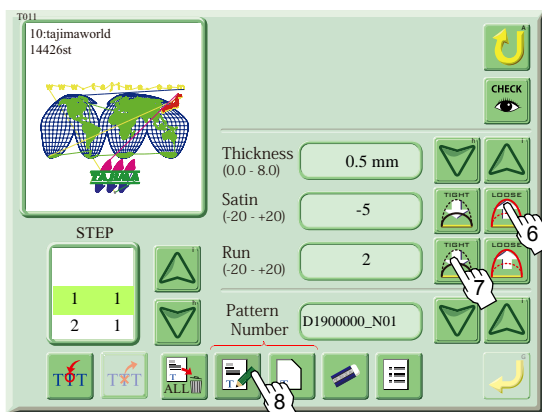

Check the adjusted value of satin stitch and running stitch, and correct the value.

- (6) Modify satin stitch.
- (7) Modify the running stitch.
- (8) Overwrite or save with a name.

Overwriting (p.7)

Saving with a name (p.6)

3-3. Saving Pattern No. with a name

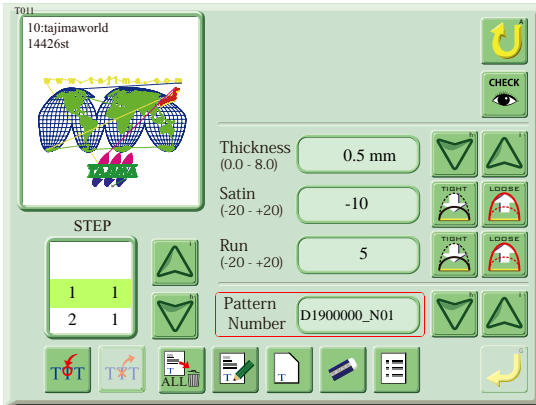

One pattern No. is applied to one step automatically.

In the initial setting of one design data, pattern No. is "Machine No. + Space + N needle bar No.", and all of pattern No. have the same setting contents.

Pattern No. can be made up to 1000 in one design.

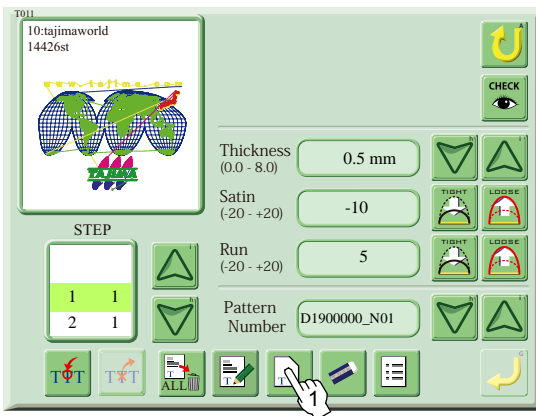

(1) Give a name to Pattern No.

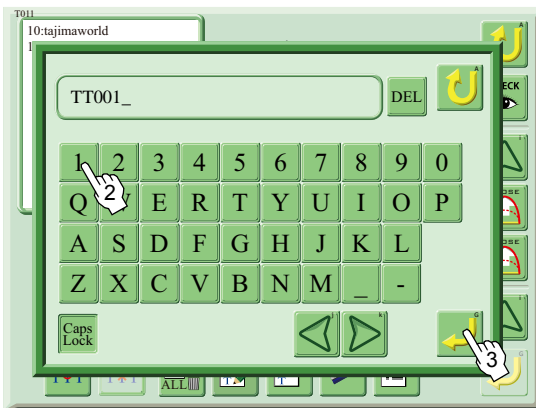

(2) Input the name.

(3) Save.

Pressing "Caps Lock" can change large letter and small letter.

 Large letter

 Small letter

Delete unnecessary characters by using "DEL" key.

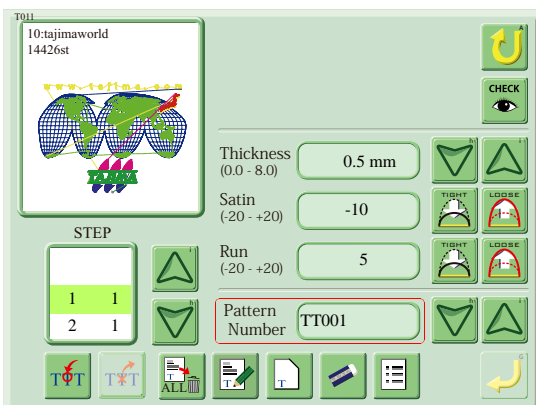

The selected pattern No. has been saved with a new name.

Resetting the pattern No. restores the initial pattern No. (p.7)

Operation

3-4. Overwriting of Pattern No.

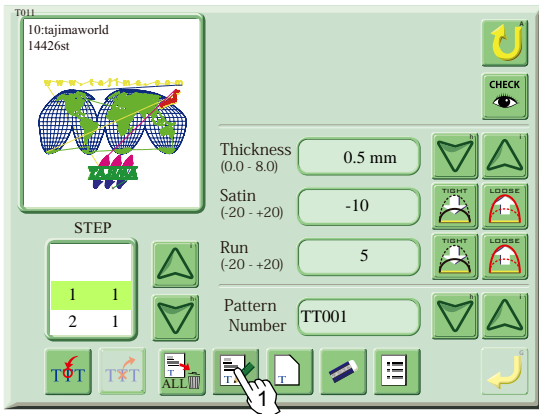

(1) Perform the overwriting of the pattern No.

☞ When there are some pattern Nos. with the same name in one design, the saving procedure of pattern No. is different from the usual.(p.10)

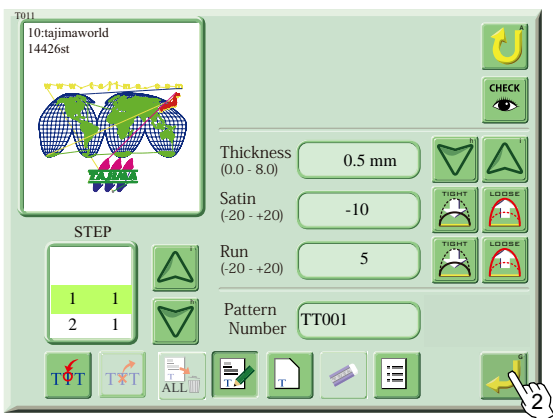

(2) Decide the overwriting.

3-5. Reset of Pattern No.

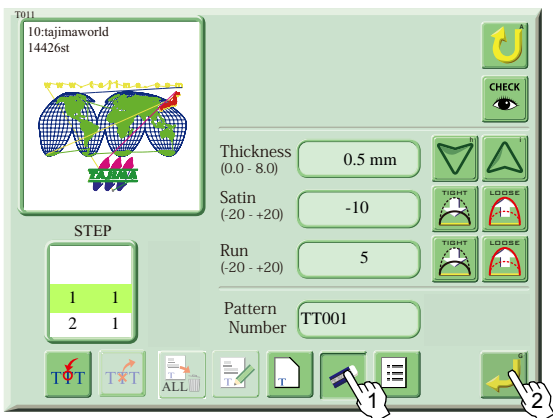

(1) Reset the pattern No. setting value and the pattern No.

(2) Decide.

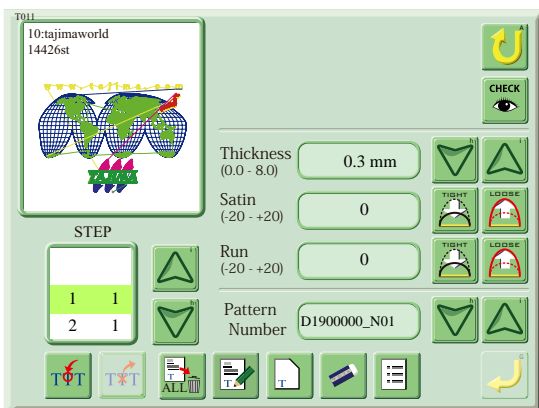

When decided, the setting value and name of the pattern No. will return to the initial setting value.

☞ Initial setting

Thickness : 0.3mm

Satin: 0

Run: 0

Pattern Number: "Machine No.+ Space + N needle bar No."

3-6. All reset of Pattern No.

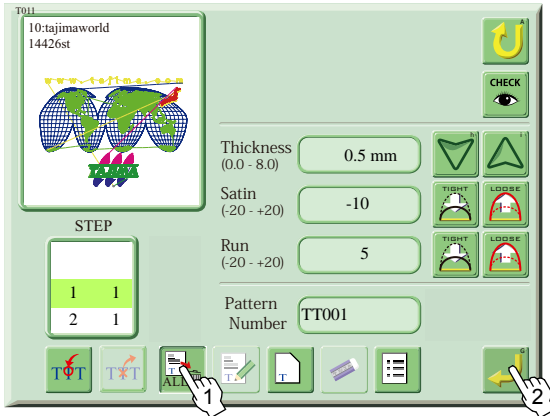

When pressing All reset button, the pattern No. saved in the data setting design will be deleted, and the setting value and name of the pattern No. will be returned to the initial value.

The inserted step remains, but the value of the assigned pattern No. will be reset.

(1) Reset all.

(2) Decide.

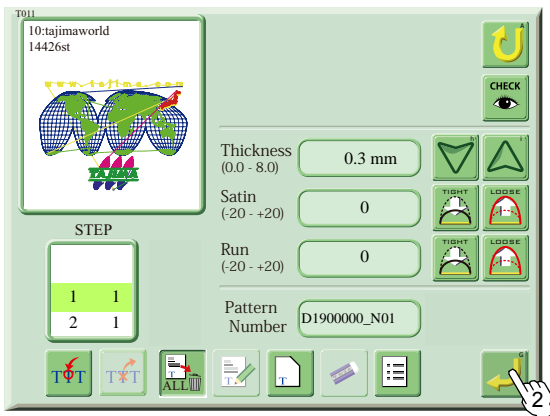

When decided, it returns to the initial setting value.

Initial setting

Thickness : 0.3mm

Satin: 0

Run: 0

Pattern Number: "Machine No.+ Space + N needle bar No."

3-7. Dividing of Step

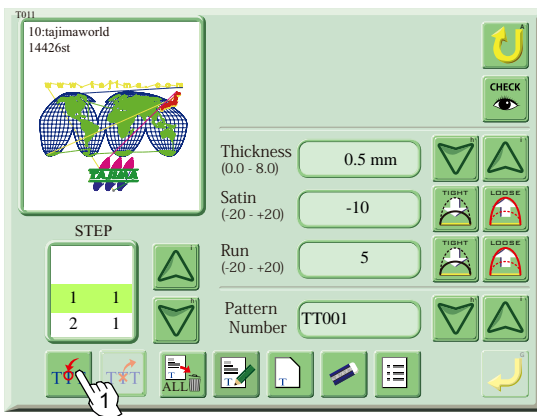

(1) Divide the step.

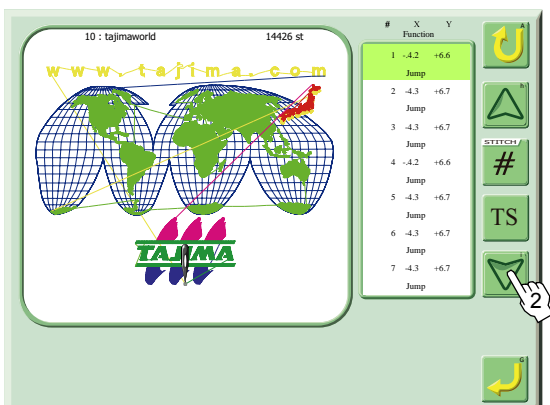

(2) Specify the position to divide the step.

Pressing the up/down key longer will forward the current position in the unit of 7 stitches.

The illustration of needle will move to the specified position.

Operation

Input with numerical key

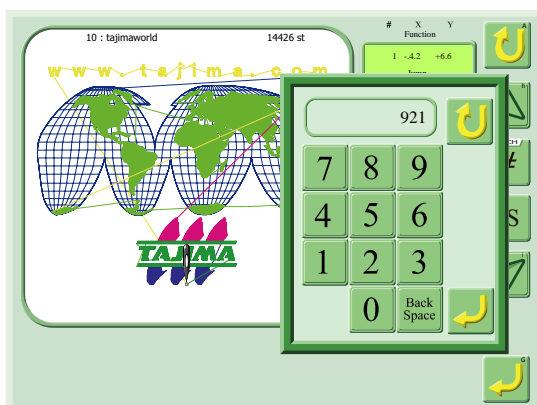

When pressing **#** key, the numerical key is displayed, and the divided position can be specified by the number of stitches.

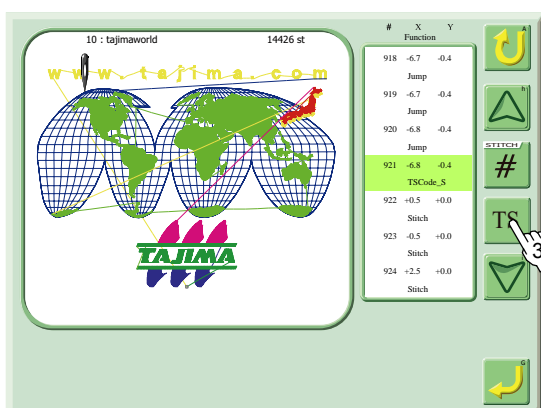

(3) Pressing "TS" key at the specified position will change the function code.

Change of Function Code

Stitch → "TScode_S"

Jump → "TScode_J"

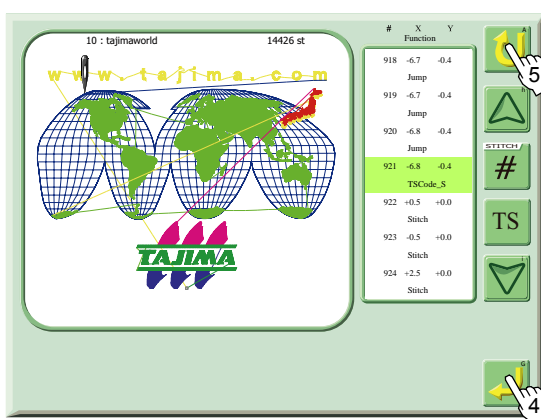

(4) Decide.

If you return the screen without the decision, it will be canceled.

By this screen (without changing the screen),
tension step can be divided multiply.

(5) Return the screen.

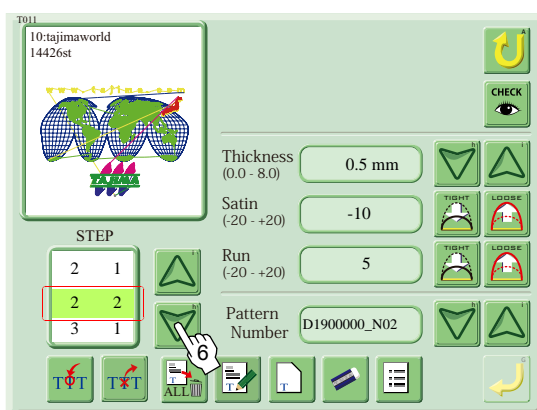

(6) Confirm the divided tension step.

The divided step has become the second of the second step.

3-8. Setting of the divided step

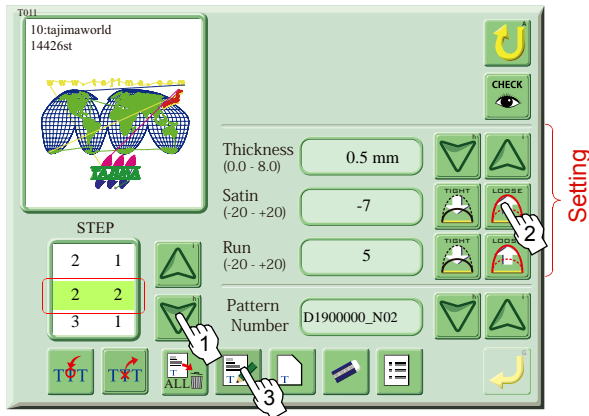

Set and save the divided step.

- (1) Select Step.
- (2) Change Tension.
- (3) Overwrite.

📖 When there are some pattern Nos. with the same name in one design, the saving procedure of pattern No. are different from the usual.

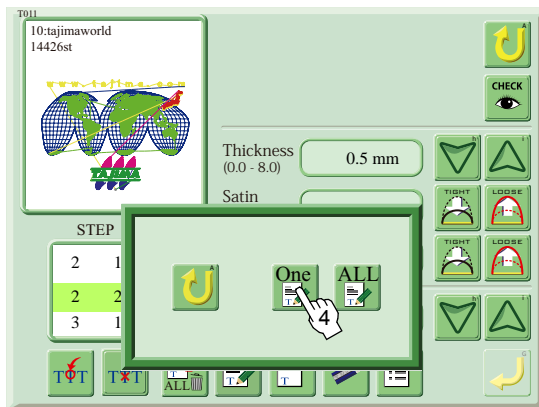

- (4) Overwrite the selected pattern No. only.

- 📖 **One** Overwriting the selected pattern No. only
- 📖 **ALL** Overwriting all pattern Nos. of the same name

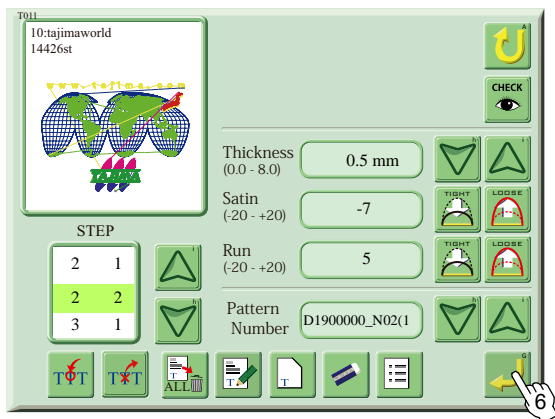

- (5) Decide.

📖 When there are two or more pattern Nos. with the same name, "(1" is added at the end of the name. If there are two or more "(1", the second "(1" will become "(2", and similarly follow as "(3", "(4".

When saving ALL

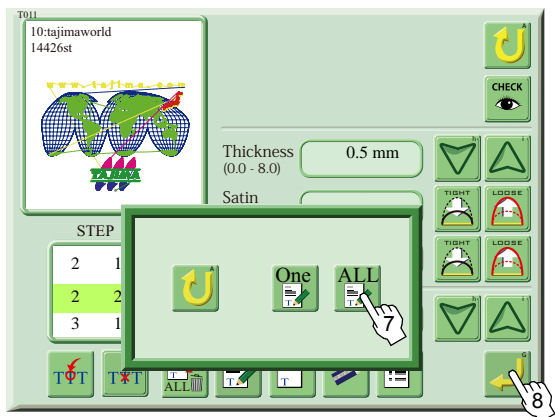

Overwrite all pattern Nos. of the same name in the data setting designs.

- (6) Overwrite all.
- (7) Decide.

Operation

3-9. Deletion of the divided step

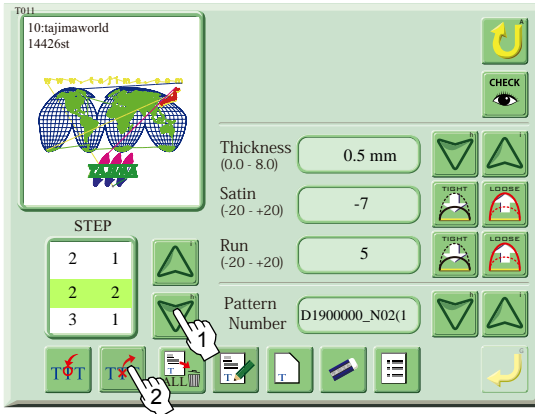

(1) Select the step to be deleted.

(2) Delete it.

The deleted icon becomes effective only when selecting the step which was made by dividing.

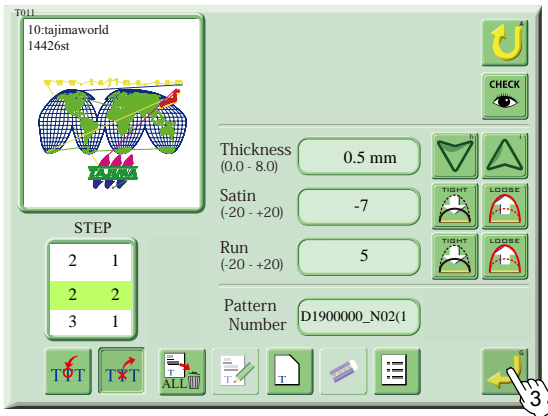

(3) Decide.

3-10. List of Pattern No.

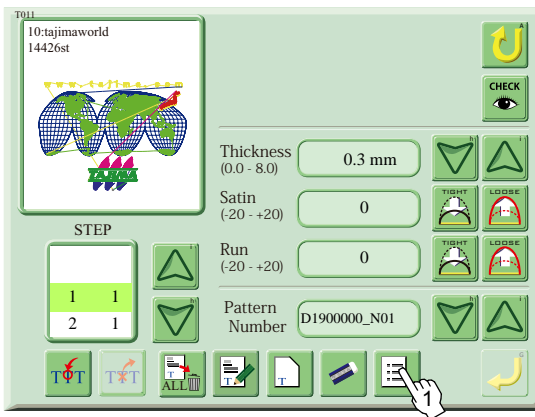

(1) Display the list of pattern No.

Tension pattern of design	Pattern Number	Thickness	Satin	Run
1	D1900000_N01	0.5	-10	5
2	D1900000_N02	0.5	-10	5
3	D1900000_N02(1)	0.5	-7	5
4	D1900000_N03	0.5	0	0
5	D1900000_N04	0.5	0	0
6	D1900000_N05	0.5	0	0
7	D1900000_N06	0.5	0	0
8	D1900000_N07	0.5	0	0
9	D1900000_N08	0.5	0	0

Switching of the display page

Change of ascending order : Name/Update time

Search by the name

Clear the name and the setting value

Change of the name

Detailed setting

Execute

3-11. Search by a name

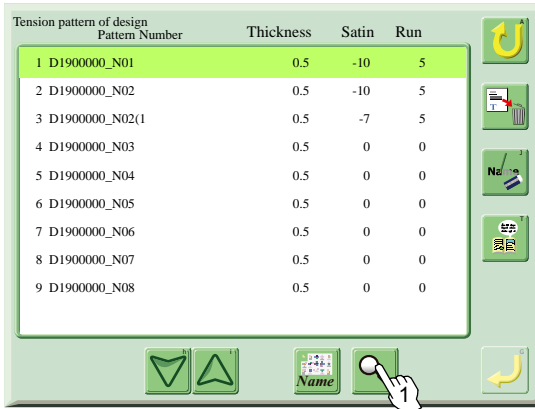

(1) Press the search key.



(2) Input the name of pattern No. to be searched.

The name of pattern No. cannot be searched unless it is input with full name.

(3) Search.

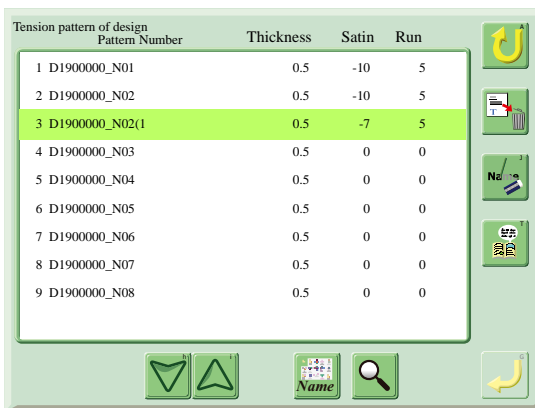

Display search results.

3-12. Clearing of Pattern

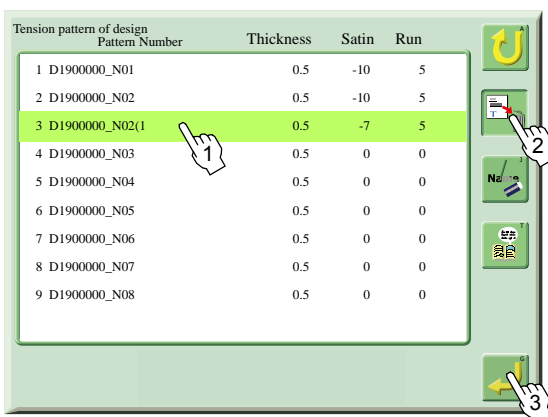

(1) Select the pattern.

(2) Clear it.

(3) Decide.

Operation

Tension pattern of design				
Pattern Number	Thickness	Satin	Run	
1	D190000_N01	0.5	-10	5
2	D190000_N02	0.5	-10	5
3	D190000_N03	0.5	0	0
4	D190000_N04	0.5	0	0
5	D190000_N05	0.5	0	0
6	D190000_N06	0.5	0	0
7	D190000_N07	0.5	0	0
8	D190000_N08	0.5	0	0

The pattern is deleted by clearing, and the final pattern will be in the selected state.

 The initial setting pattern is not deleted, but the setting value will be cleared.





3-13. Change of the name

Tension pattern of design				
Pattern Number	Thickness	Satin	Run	
1	D190000_N01	0.5	-10	5
2	D190000_N02	0.5	-10	5
3	D190000_N02(1)	0.5	-7	5
4	D190000_N03	0.5	0	0
5	D190000_N04	0.5	0	0
6	D190000_N05	0.5	0	0
7	D190000_N06	0.5	0	0
8	D190000_N07	0.5	0	0
9	D190000_N08	0.5	0	0

(1) Select the pattern.

(2) Press the name key.

Tension pattern of design				
Pattern Number	Thickness	Satin	Run	
1	D190000_N01	0.5	-10	5
2	D190000_N02	0.5	-10	5
3	D190000_N02(1)	0.5	-7	5
4	D190000_N03	0.5	0	0
5	D190000_N04	0.5	0	0
6	D190000_N05	0.5	0	0
7	D190000_N06	0.5	0	0
8	D190000_N07	0.5	0	0
9	D190000_N08	0.5	0	0



TT001_										DEL		
1	2	3	4	5	6	7	8	9	0			
Q	W	E	R	T	Y	U	I	O	P			
A	S	D	F	G	J	K	L					
Z	X	C	V	B	N	M	_	-				
Caps Lock												

(3) Input the name.

(4) Decide.

Tension pattern of design				
Pattern Number	Thickness	Satin	Run	
1	D190000_N01	0.5	-10	5
2	D190000_N02	0.5	-10	5
3	D190000_N03	0.5	0	0
4	D190000_N04	0.5	0	0
5	D190000_N05	0.5	0	0
6	D190000_N06	0.5	0	0
7	D190000_N07	0.5	0	0
8	D190000_N08	0.5	0	0
9	TT001	0.5	-7	5

Pattern No. is changed, and the order is automatically ascended in order.

  is displayed at the top in ascending order at update time.

3-14. Detailed setting

Tension pattern of design

Pattern Number	Thickness	Satin	Run
1 D1900000_N01	0.5	-10	5
2 D1900000_N02	0.5	-10	5
3 D1900000_N03	0.5	0	0
4 D1900000_N04	0.5	0	0
5 D1900000_N05	0.5	0	0
6 D1900000_N06	0.5	0	0
7 D1900000_N07	0.5	0	0
8 D1900000_N08	0.5	0	0
9 TT001	0.5	-7	5

1

2

(1) Select the pattern.

(2) Press the detailed setting.

T051

9:TT001

Thickness[mm]	0.5
Satin	-7
Run	5
0.1 - 0.9 mm	0
1.0-1.9mm	0
Inner angle[°] of stitches	180
Lock timing OFF[°]	330
Lock timing ON[°]	70

7 8 9

4 5 6

1 2 3

± 0 Back Space

Thickness, Satin and Run can be changed, but, consult the distributor for the other items

4. Parameter setting

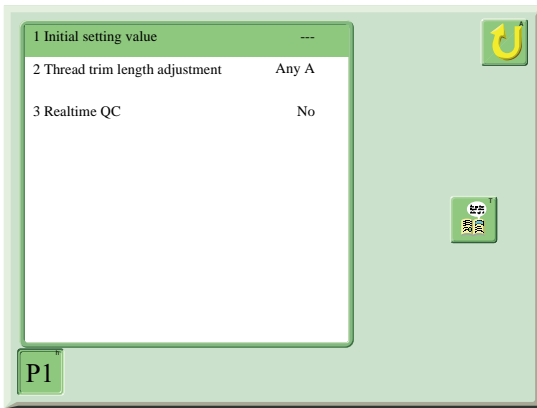
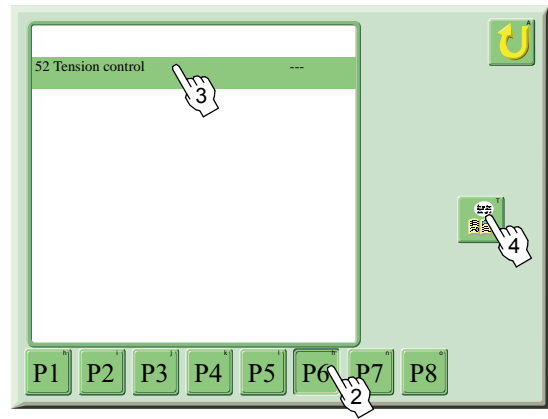
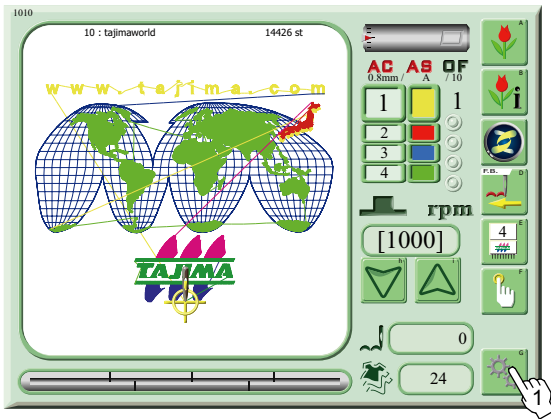

1 Setting initial value: Set the tension in the unit of needle bar.

2 Thread trim length adjustment: Set the thread trim length in the unit of needle bar.

3 Realtime QC: Set to display the upper thread tightening rate.

4-1. Initial setting value

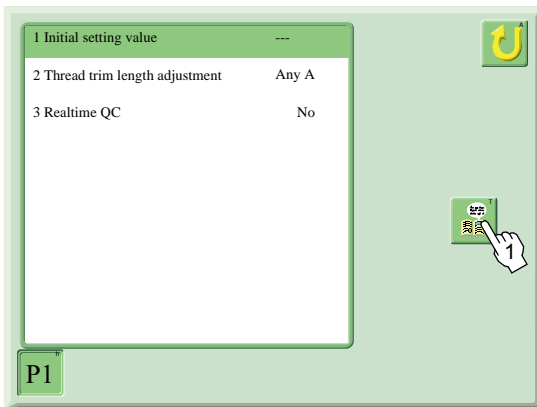

(1) Press the detailed setting.

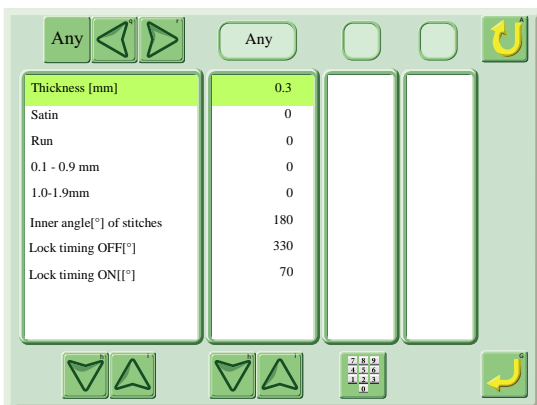

Thickness, Satin and Run can be changed, but, consult the distributor for the other items

4-2. Thread trim length adjustment

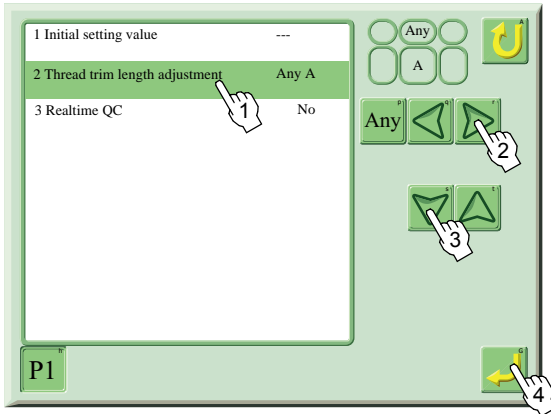

(1) Select Thread trim length adjustment.

(2) Select needle bar.

Any: Apply to all the needle bar.

(3) Select type of thread.

A: Special thread (The remaining length of the upper thread becomes long.)

No: Normal thread

(4) Decide.

4-3. Realtime QC

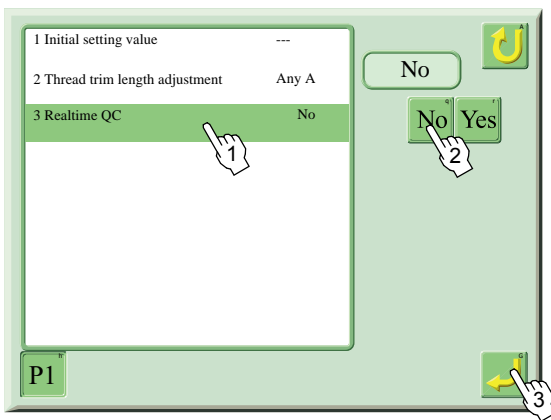

(1) Select Realtime QC.

(2) Select Yes/No.

(3) Decide.

4-4. When using boring device

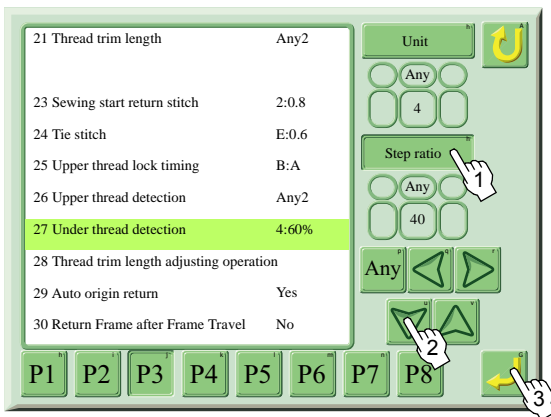

When using boring device, reduce the step ratio of "27. Under thread detection". (Recommended value: 40%)

(1) Select Step ratio.

(2) Input 40.

(3) Decide.

5. Electrical system diagram

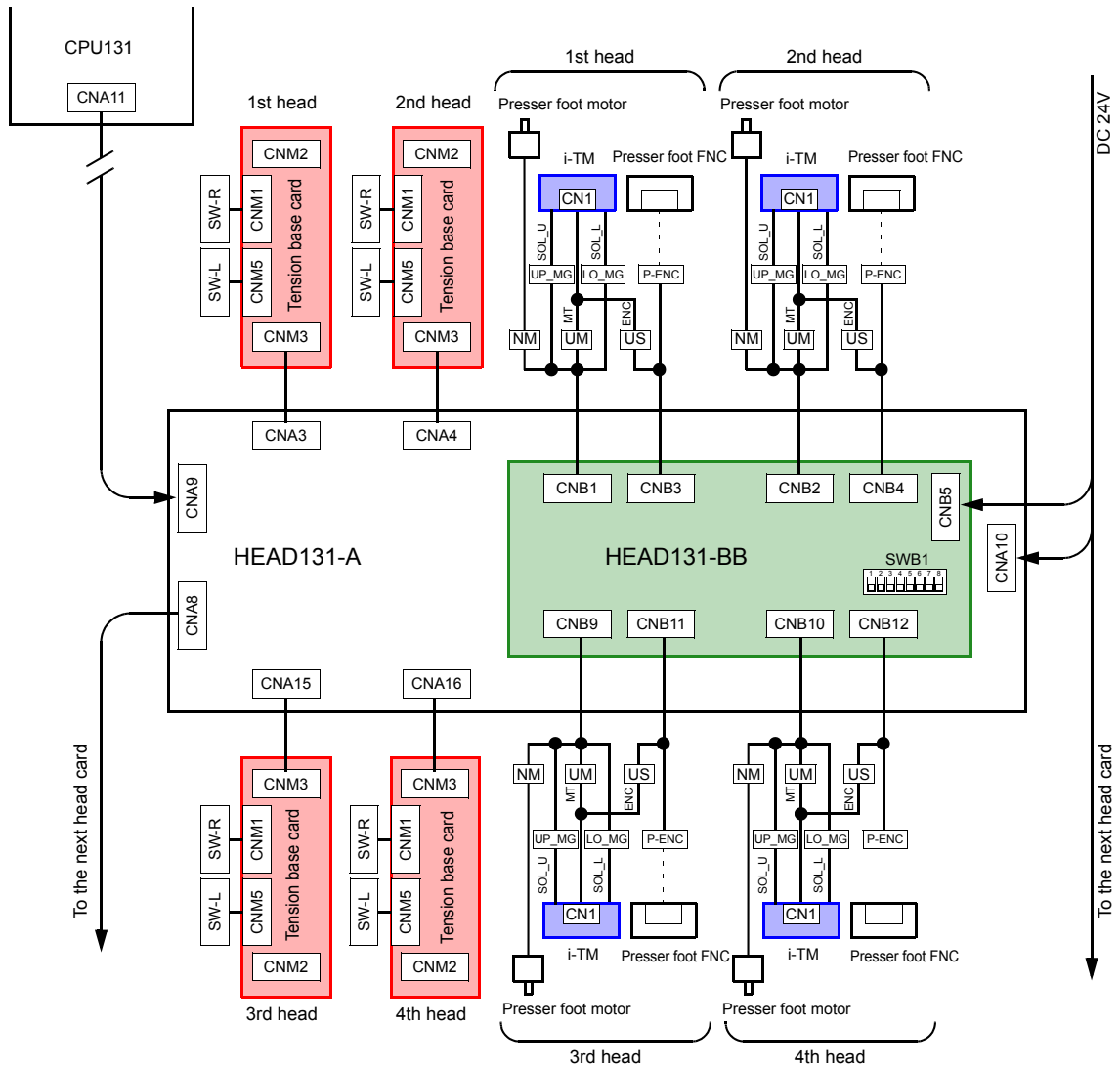

📖 Set the DIP switch (SWB1:5-8) to "OFF" to enable i-TM.

1st Edition January, 2017

5th Edition July, 2019

■ **Manufactured by : TISM Co.,Ltd.**

Address : NO.1800, Ushiyama-cho, Kasugai, Aichi-pref., 486-0901, Japan

TEL : 81-568-33-1161 FAX : 81-568-33-1191

■ **Distributed by : Tajima Industries Ltd.**

Address : NO.1800, Ushiyama-cho, Kasugai, Aichi-pref., 486-0901, Japan

TEL : 81-568-37-1130 FAX : 81-568-37-1230

●**Copy, reprint, or reform of a part or whole of this manual without permission is prohibited.**