

Instruction manual for Snarl-preventive parts

Snarl-preventive parts : 30 sets[T] Part No. : 911400100T00

◇ How to assemble

1. A set

Insert Guide 1 into Holder 3 until hearing a click sound in the state that Guide 1 is passing in Collar 2.

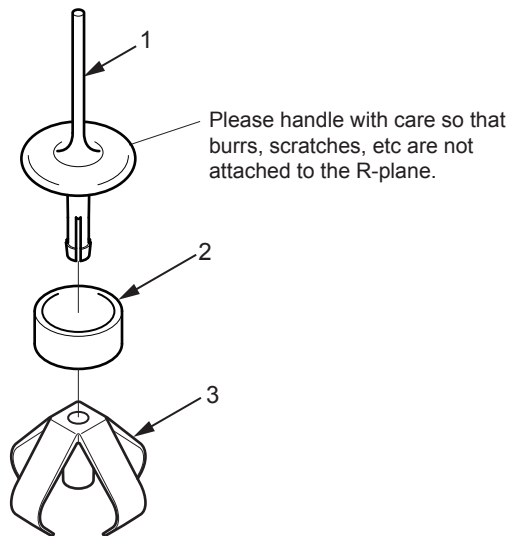

2. B set

Facing down the collar of Thread guide collar 5, fix Thread guide collar 5 in the groove from the inside of Cap 4.

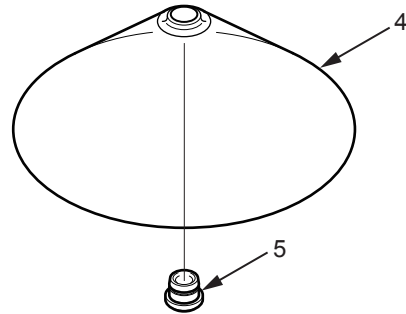

◇ How to use

1. Insert A set into the hole on the top of Thread cone and fix it.

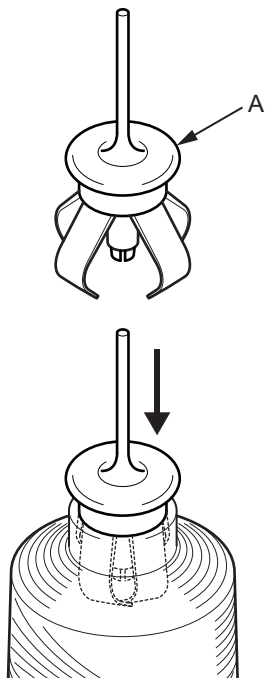

2. Pass the thread toward the top from the inside of B set. And cover the A set with the B set. After that, do the setting of thread in the machine as usual.

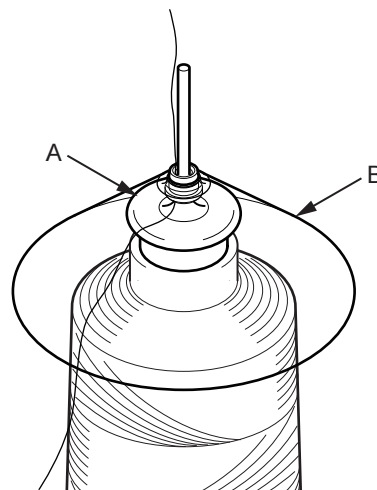

◇ Parts List

	Part Name	Part No.
1.	Guide :Snarl-preventive	0D0110540000
2.	Collar :Snarl-preventive	0D0110550000
3.	Holder :Snarl-preventive	0D0110530000
4.	Cap :Snarl-preventive	0D0110520000
5.	Thread guide collar :White :4.5mm dia.	516501010010

◇ Specification

Hole diameter on the top of thread cone: 17mm or more

◇ Note

Please treat the parts carefully when inserting or removing.