

USER'S MANUAL

LAMÉ ATTACHMENT II



Foreword

This manual is a guide book for using TAJIMA embroidery machine option “LAMÉ ATTACHMENT II” correctly. Please read this manual thoroughly, understand the contents, and then use this device.

This manual may contain discrepancies in detailed information when compared with this device due to difference of target model, continued research and improvements. If any question about the product or contents of this manual arises, please consult your TAJIMA distributor.

Please keep this manual with care near the machine for quick reference.

TISM Co.,Ltd.

Important safety instructions

Items that require your special attention on operation are specified below.



Indicates that there is a lot of danger of death or serious injuries^[*A] if the instruction is not observed.



Indicates that there is a likelihood of death or serious injuries^[*A] if the instruction is not observed.





Indicates a potentially hazardous situation which, if not avoided, may result in minor or moderate injury^[*B] or property damage.

[*A] A condition caused by electric shock, injury, fracture of a bone, etc., that leads to aftereffects, or an injury that necessitates hospitalization or visits to a hospital over a long period.

[*B] An injury that does not necessitate hospitalization or visit to a hospital over a long period.

 : Prohibited items

 : Items that may cause electric shock if not observed

 : Items that must be followed carefully to ensure safe operation

1. Caution.....	1
2. Name of each part.....	1
3. To attach lamé attachment.....	1
4. How to pass lamé filament, tension adjustment.....	4
4-1. How to pass.....	4
4-2. Tension adjustment	5
5. Setting on the operation panel	5
6. Design data to use	5

LAMÉ ATTACHMENT II

1. Caution



- ❗ To attach lamé attachment, turn "OFF" the power switch. Performing works with the power switch turned "ON" could cause unexpected malfunctioning of the machine, and you could be injured.
- ❗ Chip of lamé filament may attach to ATH knife. Clean ATH section periodically. Chip of lamé filament could cause occurrence of mis-trimming of filament.

2. Name of each part

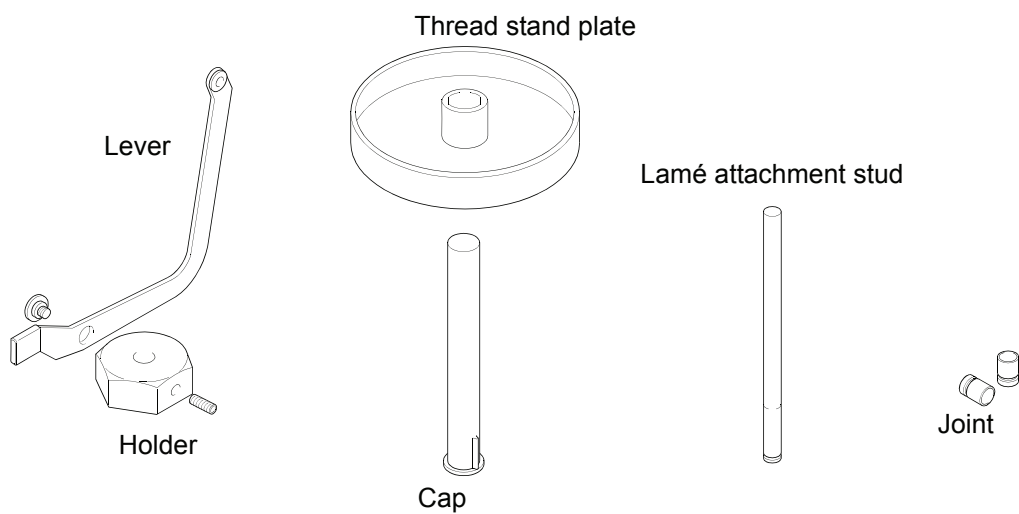

3. To attach lamé attachment

- (1) Attach the lever 1 to the holder 2, and tighten the stepped screw 3.

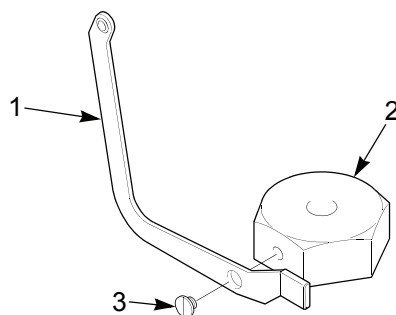

- (2) Detach the thread stand stud 4 and thread stand blade 5 at the spot where lamé attachment is attached, and attach the lamé attachment stud 6.

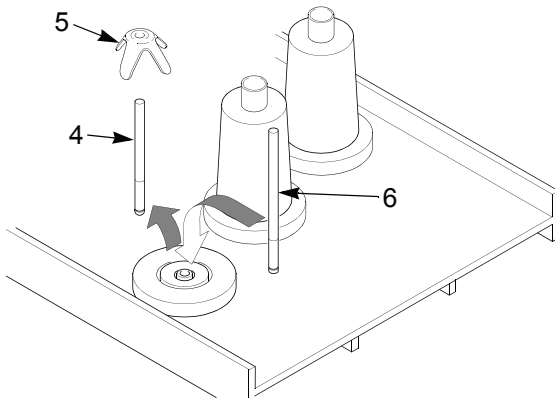

- (3) Insert the holder (2) to the lamé attachment stud (6), and tighten the screw (7).

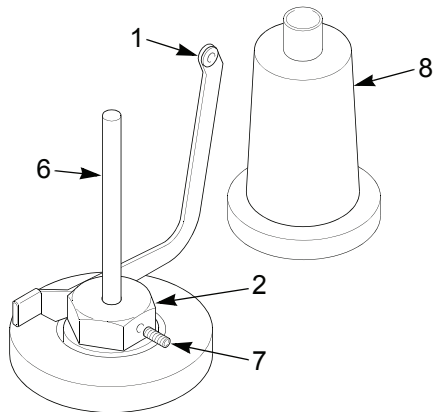

Adjust direction of the lever 1 so that it does not touch the upper thread 8.

- (4) Attach the thread stand plate (9) to the cap (8), and insert (8) to the lamé attachment stud (6).

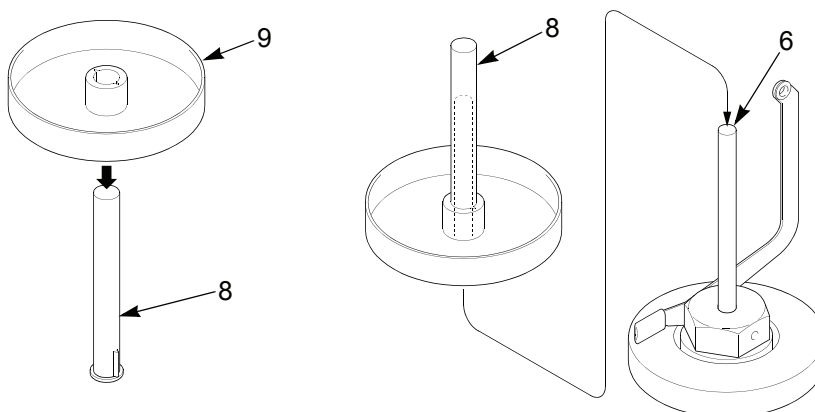

LAMÉ ATTACHMENT II

(5) Detach the spiral tube 10 and attach the joint 11.

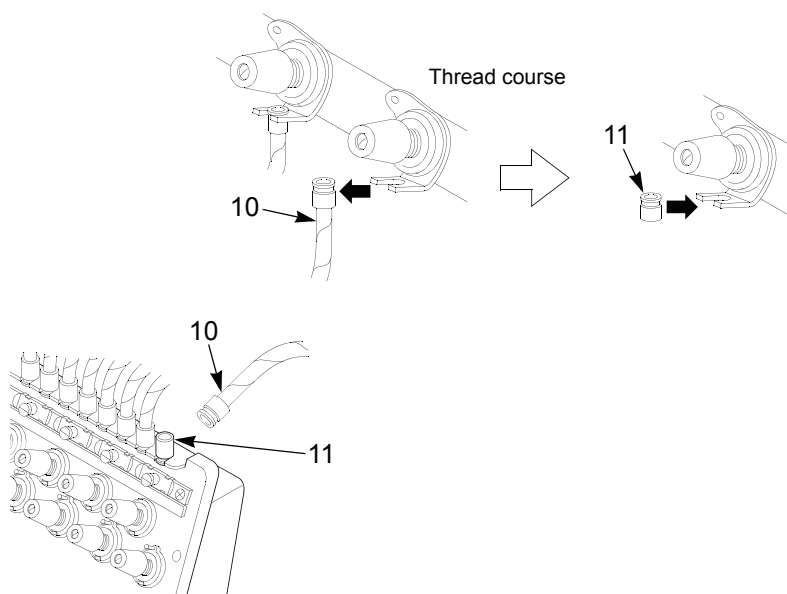

(6) Put the lamé filament 12 as shown in the figure below, and pass the lamé filament to the lever 1.

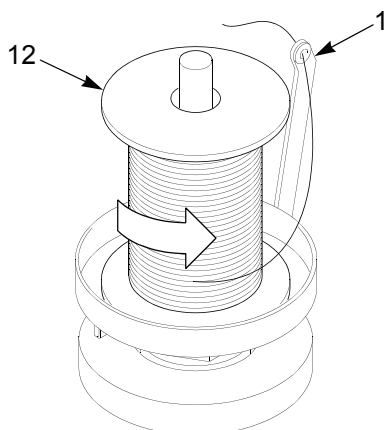

When embroidery is completed, the lamé filament 12 will have no tension. This will cause the lever 1 to tilt outside and the stopper 13 to stop rotation of the thread stand plate 9.

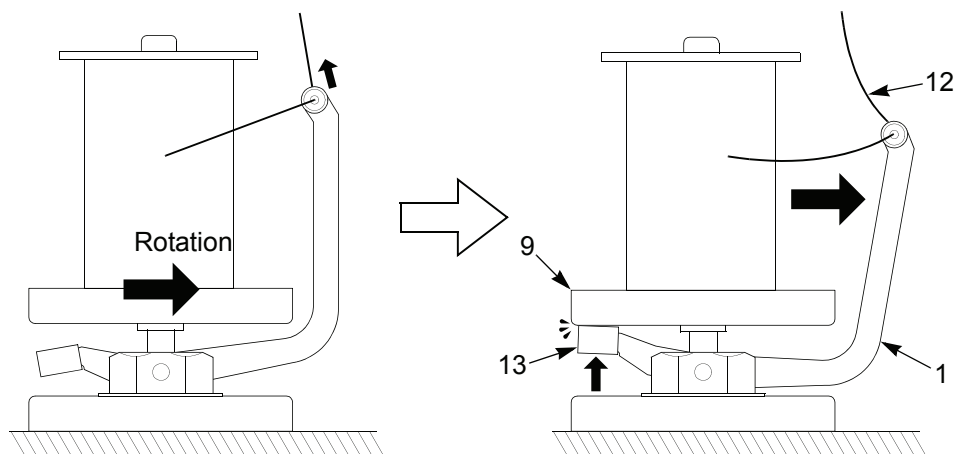

4. How to pass lamé filament, tension adjustment

4-1. How to pass

Passing lamé filament differs depending on type of tension base. If you pull lamé filament forcedly, it will extend and be deformed and it will be difficult to perform threading. When you pull out lamé filament, pull it out slowly between the thread course and tension base.

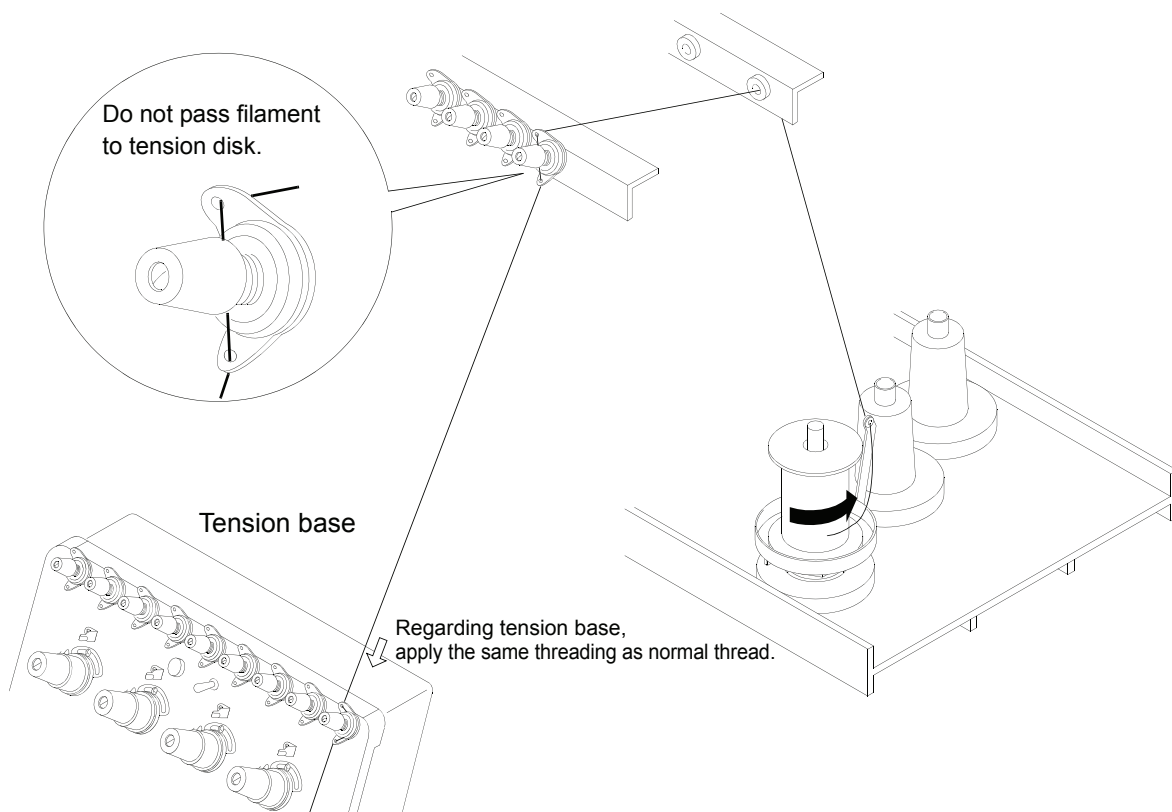
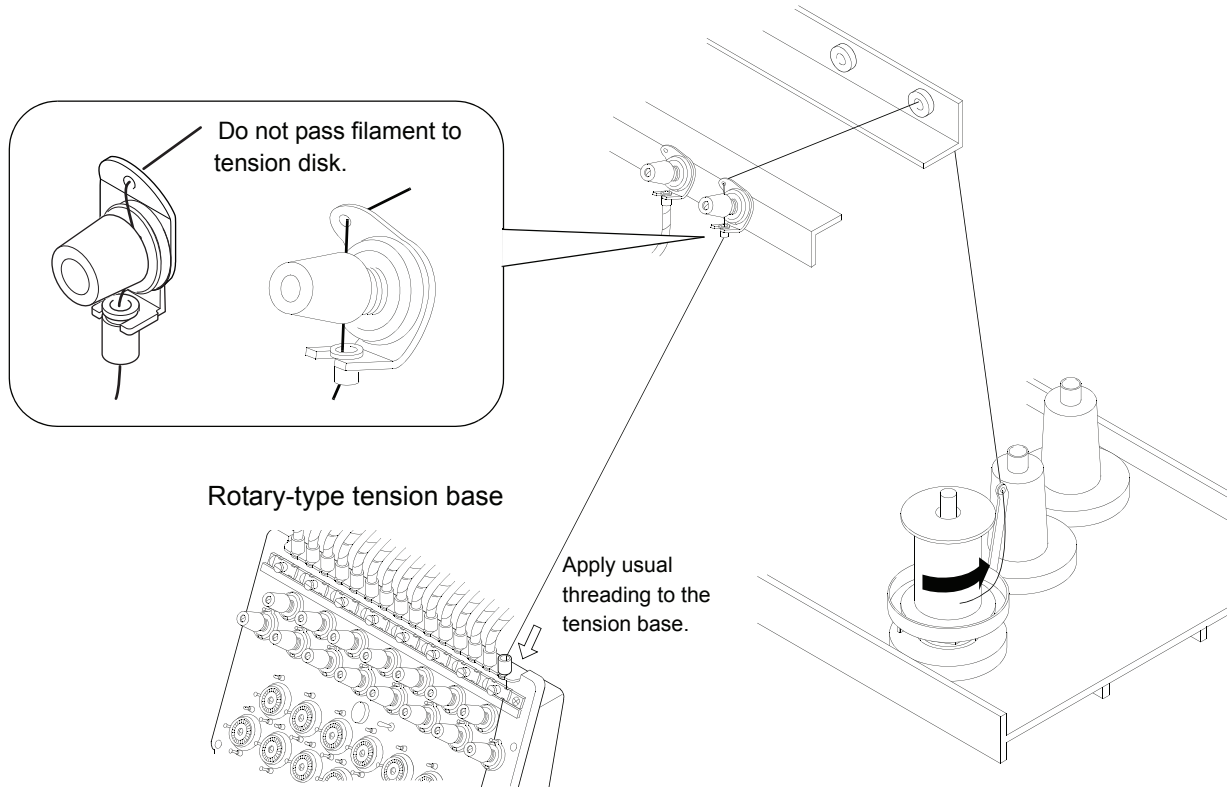

4-2. Tension adjustment

Suitable tension of lamé filament is (150 g) in the state that thread stand plate rotates slowly when you pull lamé filament that is passed to needle hole slowly (a little bit stronger than in case of using rayon thread). Adjust tension of under thread stronger than in case of using rayon thread.

5. Setting on the operation panel



Regarding how to set, refer to user's manual of the machine.

1. Set "once" for return stitching.
2. Set 0.8 for movement amount of return stitching.
3. Set "Without" to tie stitch setting.
4. Change direction of needle (turning clockwise by 30 to 45°).

When mis-stitching at start is frequent even after setting items above, decrease holding power of under thread holding spring.

6. Design data to use

1. Do not use stitch of 0.6 mm or less.
2. Do not apply tie stitching nor return stitching to the following fabric:
 - coarse fabric with large mesh count
 - delicate fabric, easy to be broken
 - fabric likely to locate the needle at the same position
3. Make thread density for satin/tatami stitch 0.5 mm or more.
4. Do not overstretch on the spot that is sewn by lamé filament.
5. When frequent misstitching occurs at start of sewing, make the machine jump to the outside of the design to lower the needle without using ATH and continue embroidery as before. After the embroidery, handle the lamé filament.



When performing overlap stitching, high density satin stitching or tatami stitching, or embroidery with short stitch length on lamé filament, the sewn lamé filament may sometimes be broken or split.

Do not use lamé filament for 3-D embroidery since it frequently generates satin stitches with thread density of about 0.2 mm.

Use design data without tie stitches, and set tie stitches in machine setting.

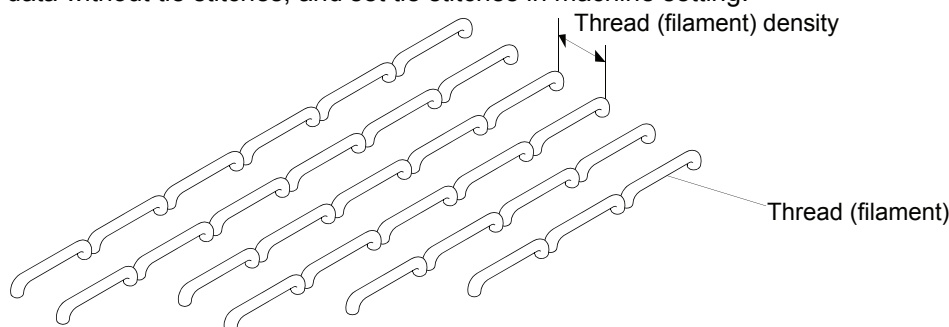

1st Edition October, 2002

5th Edition January, 2021

■ **Manufactured by : TISM Co.,Ltd.**

Address : NO.1800, Ushiyama-cho, Kasugai, Aichi-pref., 486-0901, Japan

TEL : 81-568-33-1161 FAX : 81-568-33-1191

■ **Distributed by : Tajima Industries Ltd.**

Address : NO.1800, Ushiyama-cho, Kasugai, Aichi-pref., 486-0901, Japan

TEL : 81-568-37-1130 FAX : 81-568-37-1230

●**Copy, reprint, or reform of a part or whole of this manual without permission is prohibited.**