

USER'S MANUAL
SEQUIN DEVICE III



Foreword

This user's manual describes about the correct using method and instructions for use of this product. Please use this machine after understanding the contents of the manual.

This manual may contain discrepancies in detailed specification as compared with the actual production. If you have any question about this manual, consult your TAJIMA distributor.

We believe that "BASICS TAJIMA EMBROIDERY MACHINES" and "MACHINE SETUP INSTRUCTIONS" are useful to deepen your knowledge about this product. Please also read those booklets.

Regarding how to handle the products related, refer to the user's manual exclusive for them included in the manual CD.

TISM Co.,Ltd.

SAFETY PRECAUTIONS

To prevent any harm or damage to the person who use this product or other person, we describe items that must be surely followed as below.



Indicates that there is a lot of danger of death or serious injuries [*1] if handled by mistake.




Indicates that there is a likelihood of death or serious injuries [*1] if handled by mistake.





Indicates a potentially hazardous situation which may result in minor or moderate injury [*2] or property damage if handled by mistake.

*1: A condition caused by electric shock, injury, fracture of a bone, etc., that leads to aftereffects, or an injury that necessitates hospitalization or visits to a hospital over a long period.

*2: An injury that does not necessitate hospitalization or visit to a hospital over a long period.

: Prohibited items

: Items that may cause electric shock if not observed

: Items that must be followed carefully to ensure safe operation


Chapter 1	Outline of the device	1
1.	Instructions for use	1
2.	Name of each part	3
3.	Main functions.....	4
4.	Color change position	4
5.	Upper dead point, middle point, lower dead point	5
6.	About the sequin that can be used	5
Chapter 2	Composed parts	6
1.	Parts near needle (TMAR).....	6
2.	Parts near needle (TFMX, TFMX-C).....	8
3.	Sequin guide (common to models).....	9
Chapter 3	Setting of sequin	10
1.	Setting of sequin	10
Chapter 4	Change and attaching of sequin guide	14
1.	Detaching of the lower unit	14
2.	Changing example of sequin guide	14
Chapter 5	Adjustment of each part	16
1.	Height of device	16
2.	Cut position.....	17
3.	Needle locating position (front/rear).....	21
4.	Needle locating position (right/left)	22

Chapter 6	Setting and operation	25
1.	TMAR	25
1-1.	Basic settings	25
1-2.	Setting of sequin chip feed amount	26
1-3.	Insertion of Jump at Sequin	27
1-4.	Auto lifting - Sequin device	29
1-5.	Sequin chip feed	30
1-6.	Moving up/down and color change operation	32
2.	TFMX, TFMX-C	34
2-1.	Basic settings	34
2-2.	Setting of sequin chip feed amount	35
2-3.	Insertion of Jump at Sequin	36
2-4.	Auto lifting - Sequin device	38
2-5.	Sequin chip feed	39
2-6.	Moving up/down and color change operation	41
Chapter 7	Troubleshooting	42
1.	Cause and remedy	42
1-1.	Error code	42
1-2.	LED display	43
1-3.	Up/down motion at frame back	44
1-4.	When sequins are turned over	45
2.	Lubrication and greasing	47

Chapter 1 Outline of the device

1. Instructions for use

CAUTION

-  In some models, lower units are packed separately at shipment from the factory. In this case, follow the procedure described below and make the device available for use.

Procedure:

- (1)** As shown in the figure 1, attach the lower unit that is packed separately to the upper unit by using the stepped screw that is also packed separately. One unit of sequin has four pieces of the attaching screw.



The number-indicated label corresponding to the head number is attached to the package of the separated lower unit for your reference.

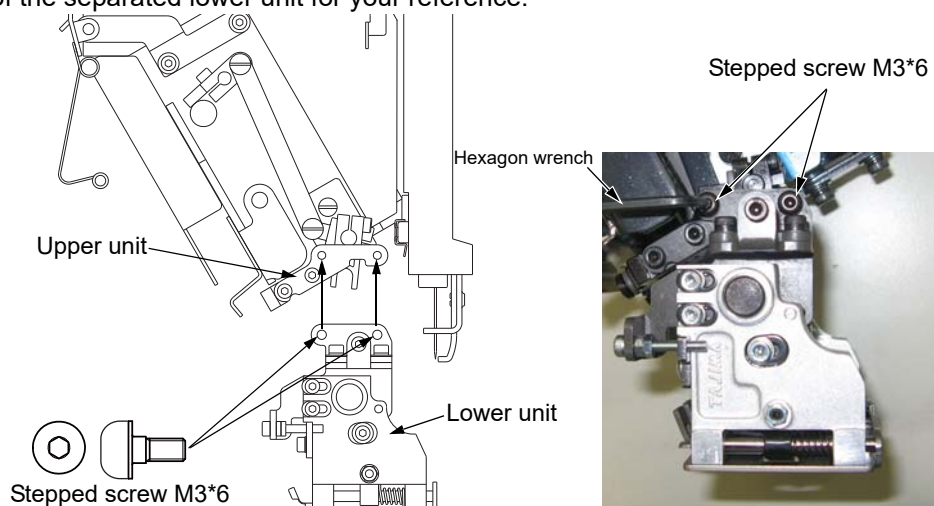


Fig. 1

- (2)** Check if the device has become the state of figure 2 and the lower unit moves right and left smoothly.

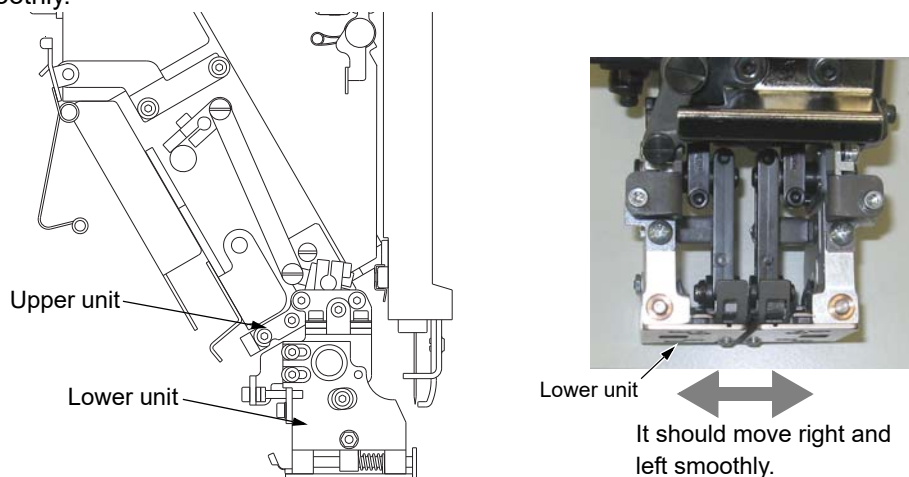
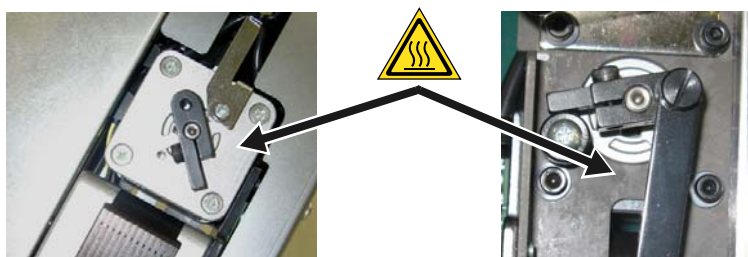


Figure2

CAUTION

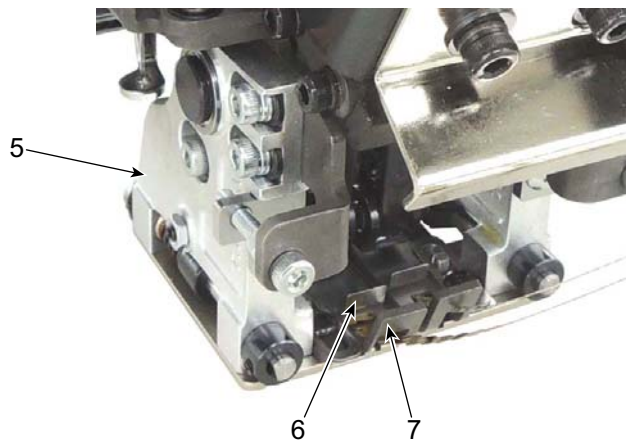
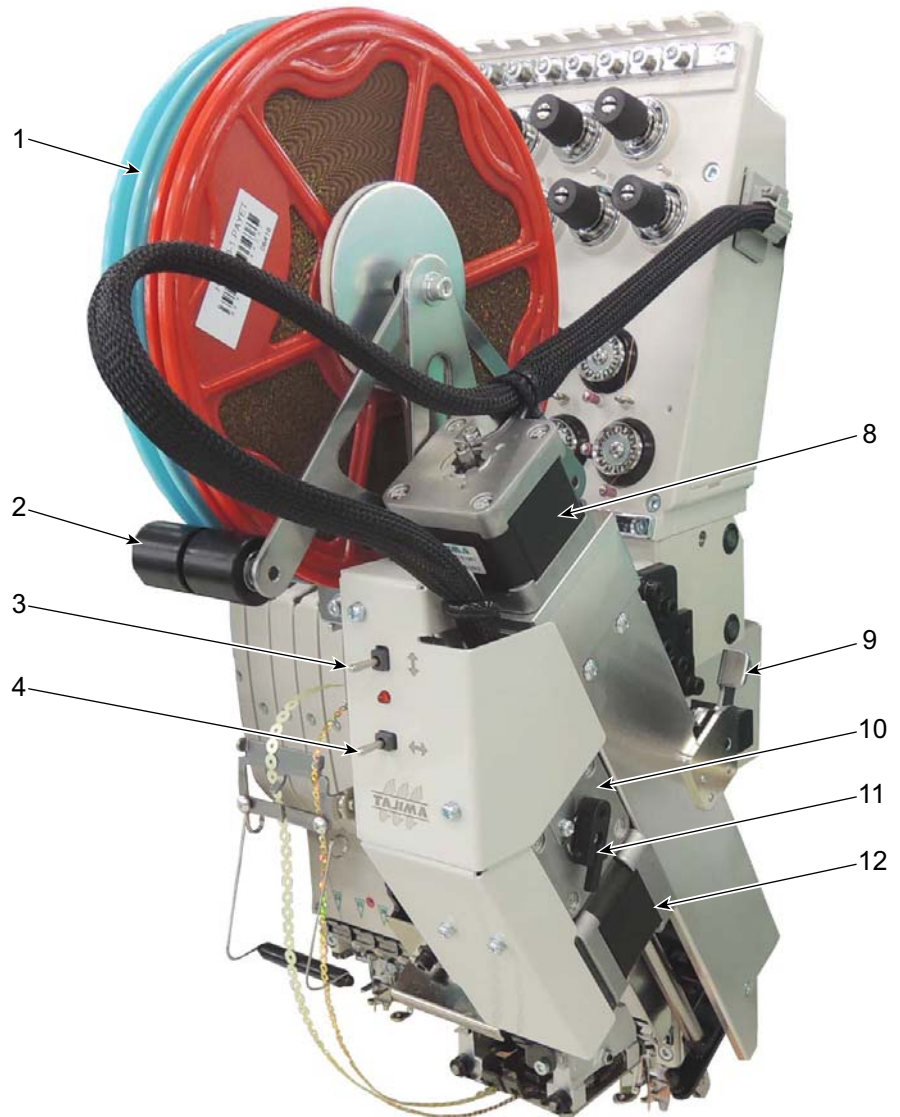
- ⊘ Do not change the spec. of the machine. When you change the frame spec. (S, W, 2W, 3W, WE or WJ) that is set at shipment, troubles such as no actuation, malfunctioning of the device, etc. will occur.
- ! When you perform other works than those described in “Setting • operating instructions” in this user’s manual, turn “OFF” the power switch. Performing works with the power switch turned “ON” could cause unexpected malfunctioning of the machine and you could be injured.
- ! When you use sequin device, embroidery space will be limited. Before performing embroidery, keep this device raised, then check embroidery space by “Trace” operation to confirm that this device does not hit the frame.
- ! To perform color changing automatically, it is necessary to use data made of TAJIMA binary format (TBF) including sequin output 2 code. For details, refer to the manual of the software “DG/ML by Pulse” that is packed with the machine.
- ⊘ When you turn on the power, do not put your hands etc. near the needle or on the machine table. You could be injured by moving up device.
- ⊘ When you perform color change, do not put your hands etc. near the needle or on the machine table. Moving up/down of the device could injure you.
- ! Pay attention when you touch the stepping motor by hand. You could be burnt by high temperature.



- ! When you perform threading, replacement of material (Sequin) or other adjustment, pay attention to the protruding parts of the device because your face or head comes in contact with the protruding parts and you could be injured.

2. Name of each part

1. Sequin reel
2. Flat pulleys
3. Up/down switch
4. Color change switch
5. Lower unit
6. Sequin plate spring
7. Sequin guide
8. Pulse motor for moving up/ down
9. Clutch lever
10. Pulse motor for sequin feed
11. Sequin lever
12. Pulse motor for sequin color change



3. Main functions

- It is possible to embroider four kinds of sequin at the maximum.

It is possible to mount two types (different colors or diameters) of sequin to embroider two kinds of sequins by switching sequins quickly during embroidery. When the devices are attached to both sides (right and left sides) of a head, it is possible to embroider four kinds of sequin at the maximum.



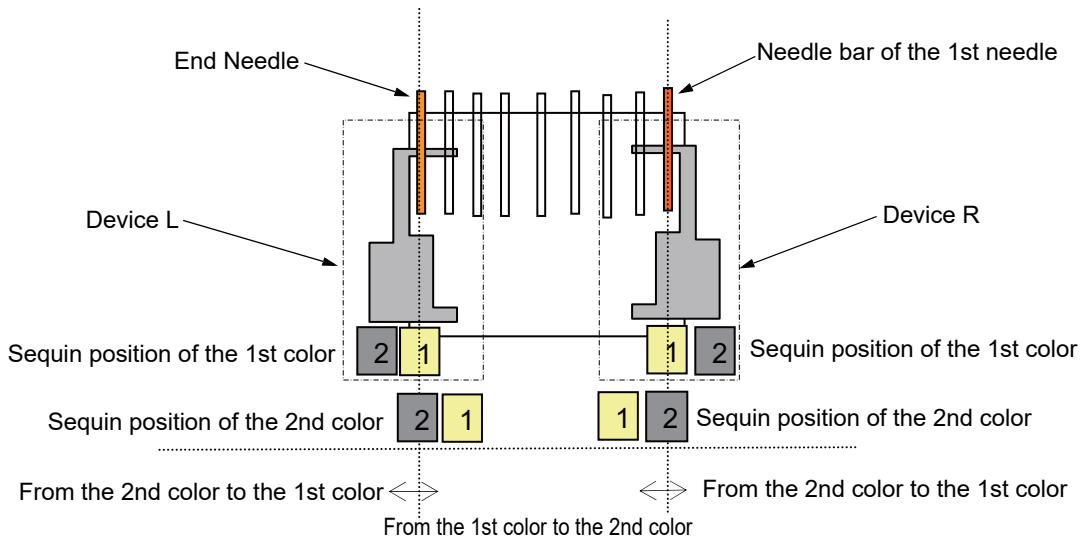
In addition, color change is not performed automatically unless data consists of TAJIMA binary format (TBF) including sequin output 2 code. Regarding how to make data etc., please ask the distributor for information.

- It is possible to detect running out of material. (Option)

When sequins wound on a reel run out in the middle of embroidery, the sensor will immediately work to stop the embroidery machine.

4. Color change position

The 1st color of the device becomes the reference position, and the device will always move once to this reference position before sequin embroidery starts.



5. Upper dead point, middle point, lower dead point

The device is positioned at one of the upper dead point, middle point or lower dead point and the relationship of positions is shown as the illustration below..

- Upper dead point

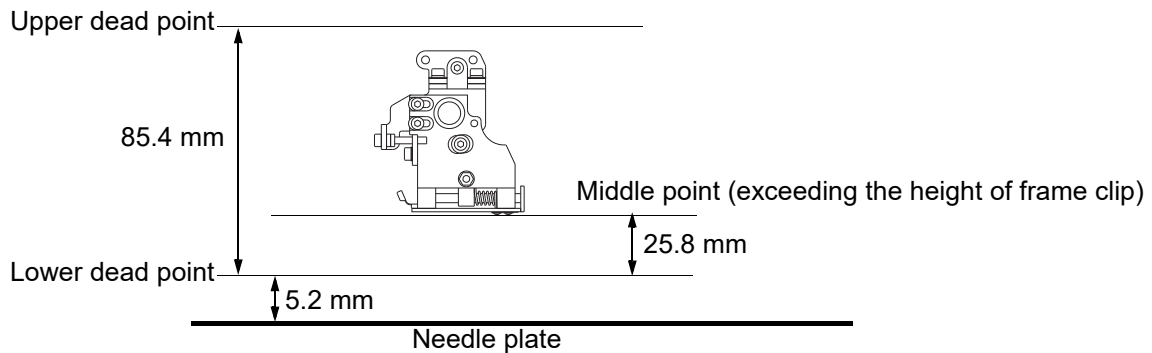
The highest retractable position when the device moves up (the position of the device at frame stepping, thread breakage, etc.)

- Middle point

The position where the device stays at a height that does not hit the frame clip (the position of the device when Frame Back is performed at the head without thread breakage, when ATH works, when material runs out, etc)

- Lower dead point



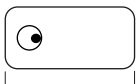
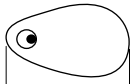
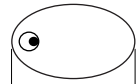

The lowest position when the device moves down (the position of the device at sequin embroidery)



6. About the sequin that can be used

The table below shows the sequin sizes that can be used with the device.

The mark with • in the table below indicates the needle location position.

2 to 9 mm sequin					
2 to 9 mm dead center sequin	9 mm or less special-shaped sequin				
	Ring	Strip	Tear drop	Ellipse	Front hole eccentric
 2 to 9 mm	 9 mm or less	 9 mm or less	 9 mm or less	 9 mm or less	 9 mm or less

Chapter 2 Composed parts

1. Parts near needle (TMAR)

1. Needle clamp :Sequin

2. Needle

2 mm dead center sequin	DB-K5SS #65/9
3 to 9 mm Dead center sequin	Normal needle (Needle type is not specified.)
9 mm or less Special-shaped sequin	

3. Shaft :Sequin presser foot

4. O-ring :SO-3-90

5. Presser foot :Sequin :Cap/10 mm or more dia.

6. PRESSER FOOT :SEQUIN :9MM OR LESS DIA.

7. PRESSER FOOT :SEQUIN :7MM OR LESS DIA.

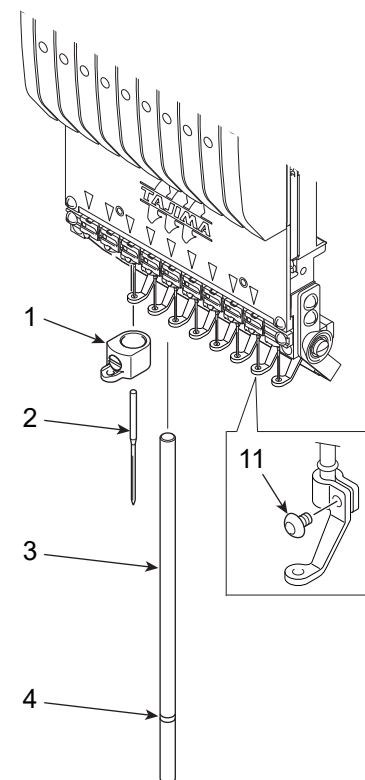
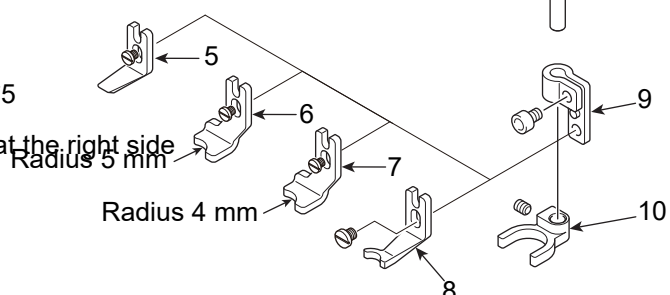
8. PRESSER FOOT :SEQUIN :2-4MM DIA.

9. Base :Sequin presser foot :B

10. Movable knife presser

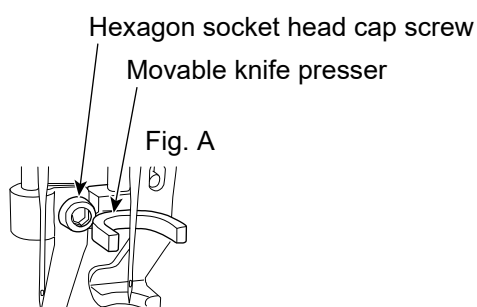
11. Hexagon socket head button screw :M3*5

2nd needle when the device is installed at the right side
(Refer to [Note] below.)



[Note]

When installing the sequin device on the right side, replace the 2nd presser foot set screw from the hexagon socket head cap screw to the hexagon socket head button screw (M3*5). If it is not replaced, the movable knife presser may hit the hexagon socket head cap screw when the 2nd needle is lowered as shown in figure A.



The table below shows the sequin presser foot corresponding to sequin to be used.

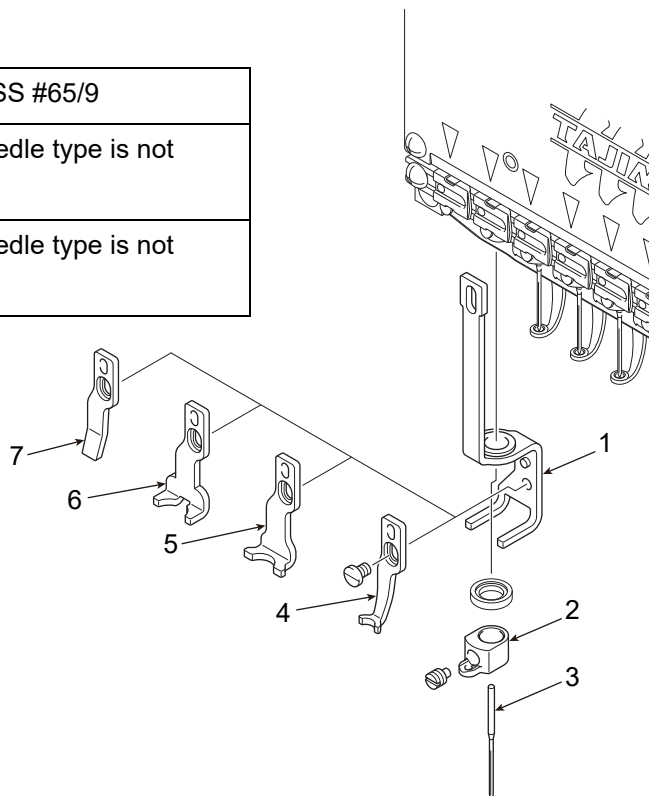
Sequin type	Sequin size	Sequin presser foot
Dead center sequin	2 to 4 mm	Presser foot :Sequin :2-4 mm dia.
	5 to 7 mm	Presser foot :Sequin :7mm dia. or less
	8 to 9 mm	Presser foot :Sequin :9mm dia. or less
	For cap frame	PRESSER FOOT :SEQUIN :CAP/ 10MM OR MORE DIA.
Special-shaped sequin	9 mm ring, 9 mm front hole eccentric	Presser foot :Sequin :9mm dia. or less
	7 mm ring, 3 x 6 mm strip, 3 x 9 mm strip, 5 x 9 mm tear drop, 7 x 9 mm ellipse	Presser foot :Sequin :7mm dia. or less

2. Parts near needle (TFMX, TFMX-C)

1. Base :Sequin presser foot :47st[S]
2. Needle clamp :Sequin
3. Needle

2 mm sequin	DB-K5SS #65/9
3 to 9 mm Dead center sequin	Normal needle (Needle type is not specified.)
9 mm or less Special-shaped sequin	Normal needle (Needle type is not specified.)

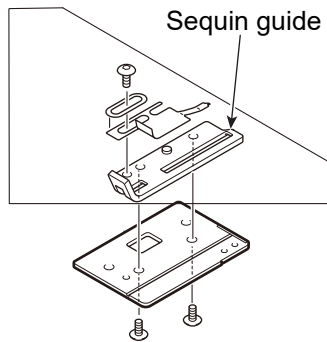
4. Presser foot :Sequin :2-4 mm dia.
5. Presser foot :Sequin :7mm dia. or less
6. Presser foot :Sequin :9mm dia. or less
7. Presser foot :Sequin :Cap
(For TFMX-C)



The table below shows the sequin presser foot corresponding to sequin to be used.

Sequin type	Sequin size	Sequin presser foot
Dead center sequin	2 to 4 mm	Presser foot :Sequin :2-4 mm dia.
	5 to 7 mm	Presser foot :Sequin :7mm dia. or less
	8 to 9 mm	Presser foot :Sequin :9mm dia. or less
	For cap frame	Presser foot :Sequin :Cap
Special-shaped sequin	9 mm ring, 9 mm front hole eccentric	Presser foot :Sequin :9mm dia. or less
	7 mm ring, 3 x 6 mm strip, 3 x 9 mm strip, 5 x 9 mm tear drop, 7 x 9 mm ellipse	Presser foot :Sequin :7mm dia. or less

3. Sequin guide (common to models)



There are following types of sequin guides. Select it according to the size of sequin.

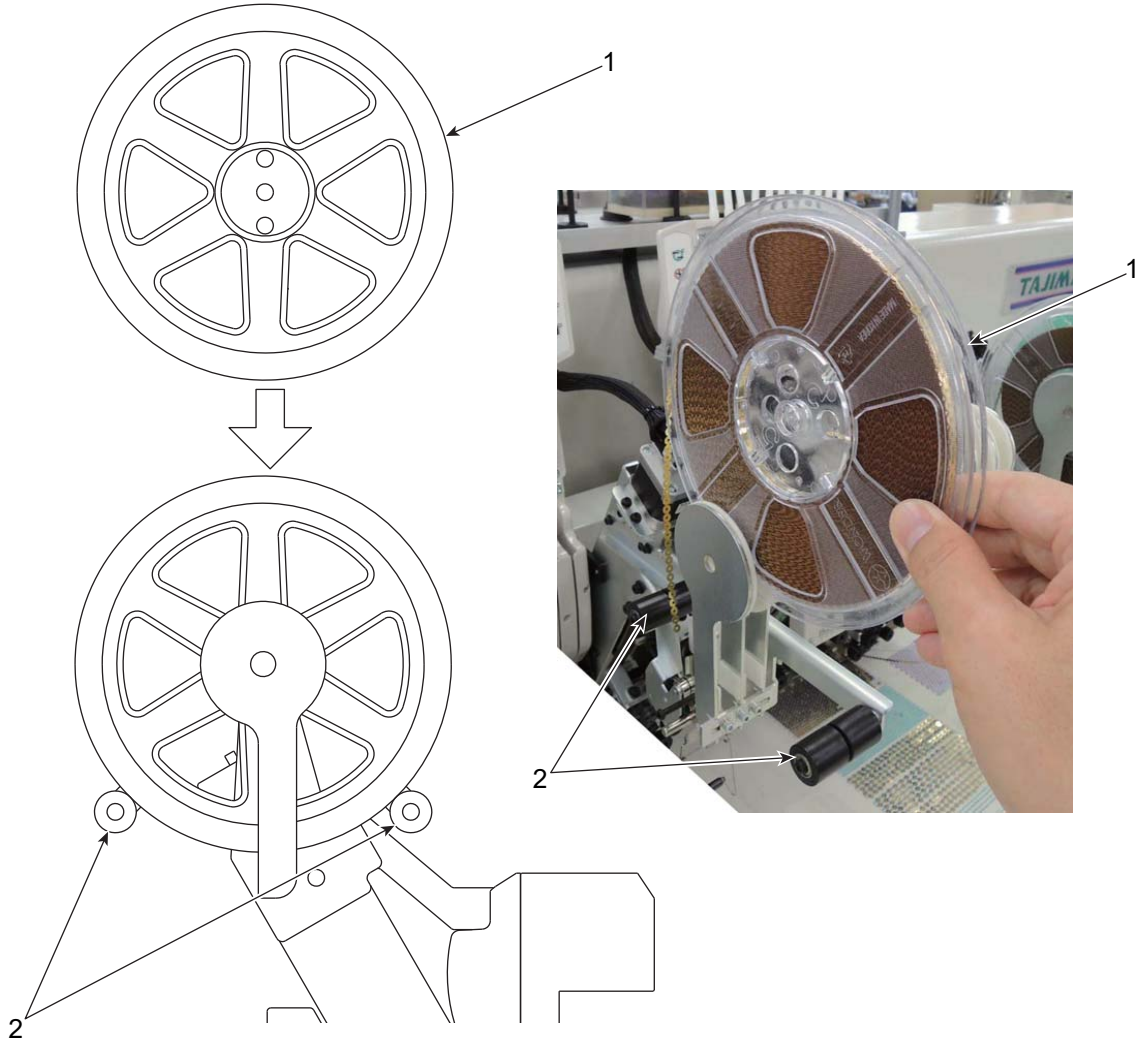
However, sequin guides (b) to (g) in the chart below cannot be used together with the sequin of 2 mm and 3 mm at the same time. Besides, sequins (b) to (g) require exclusive lower unit.

Sequin	Sequin guide
Dead center sequin	2 mm, 3 mm, 4 mm, 5 mm, 7 mm, 9 mm
Special-shaped sequin	(a) 7 mm ring (b) 9 mm ring (c) 3 x 6 mm strip (d) 3 x 9 mm strip (e) 5 x 9 mm tear drop (f) 7 x 9 mm ellipse (g) 9 mm front hole eccentric

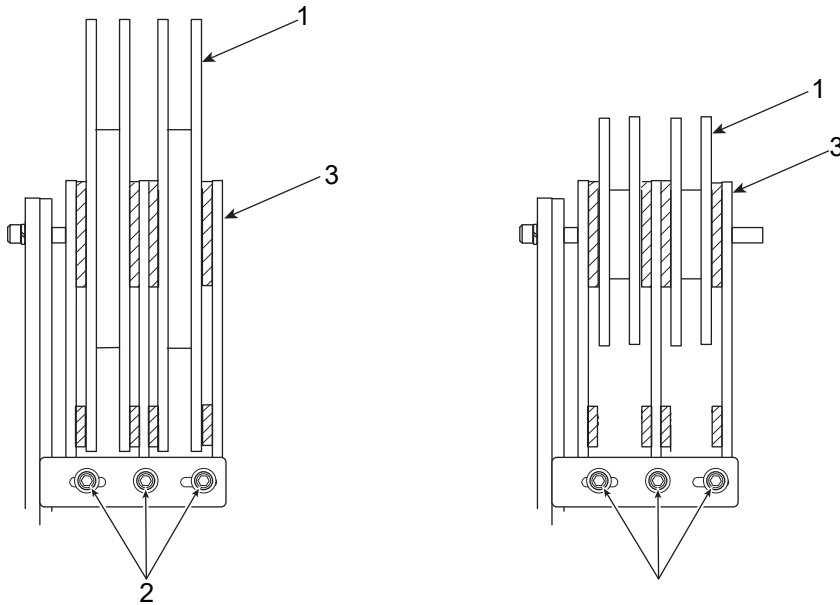
Chapter 3 Setting of sequin

1. Setting of sequin

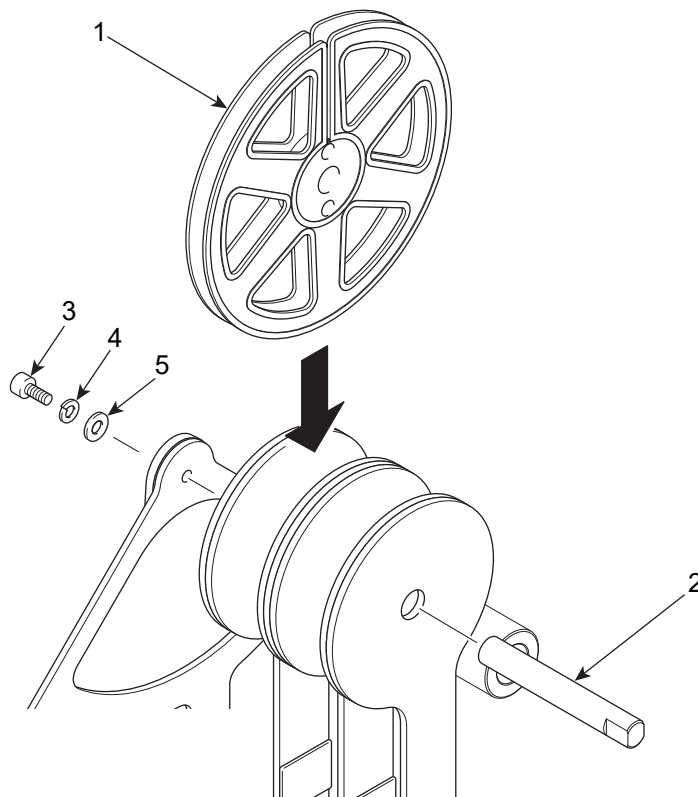
(1) Put the sequin reel 1 on flat pulleys 2.



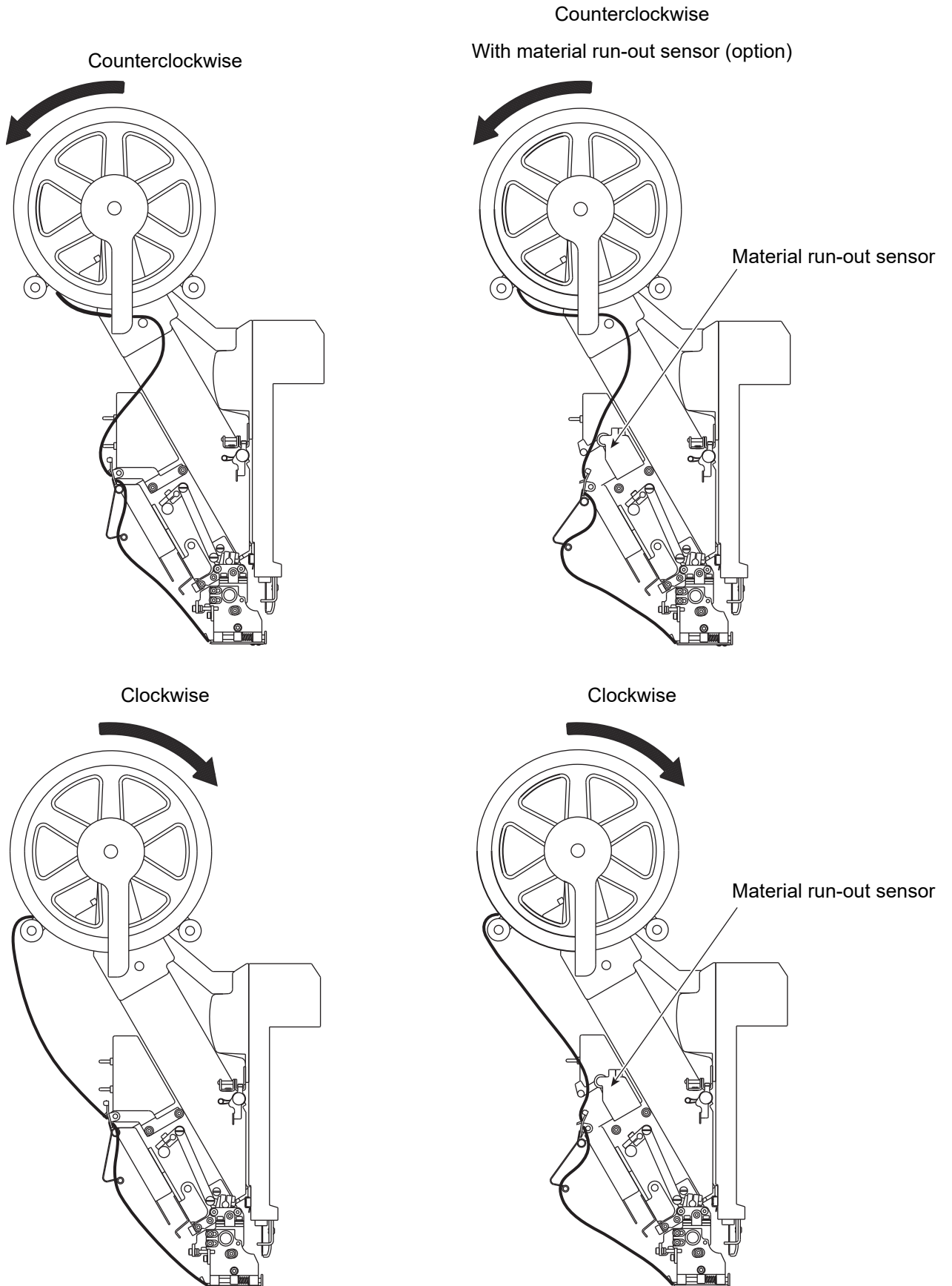
- (2) If the sequin reel 1 does not rotate smoothly, loosen screws 2 to adjust the position of the sequin reel guide 3.



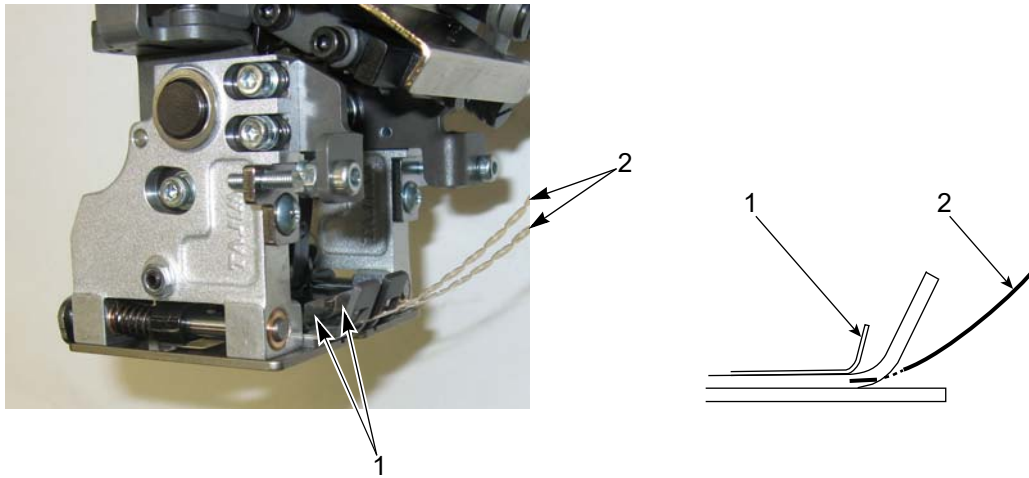
- (3) For the small diameter sequin reel 1, use the accessory straight pin 2, the screw 3 (hexagon socket head cap screw M4*10), the spring washer 4 (M4) and the plain washer 5 (M4*10).



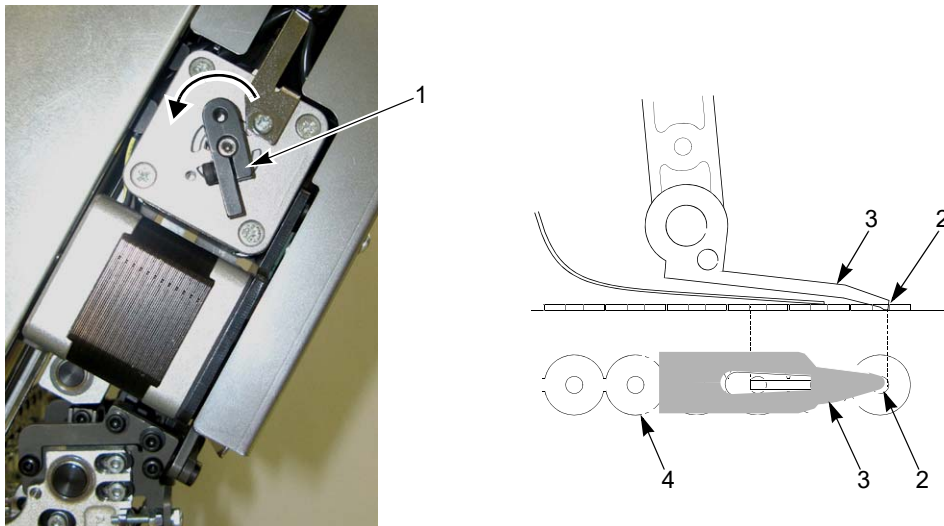
- (4) Pass sequins through each section. The front side or the back side of sequin becomes opposite depending on the style of placing the sequin reel.



(5) Insert sequins 2 under the plate spring 1.



(6) Push sequins 4 further so that the sequin feed pawl 3 enters into the hole 2 of the top of sequins in the state the motor sequin lever 1 is turned.



Chapter 4 Change and attaching of sequin guide

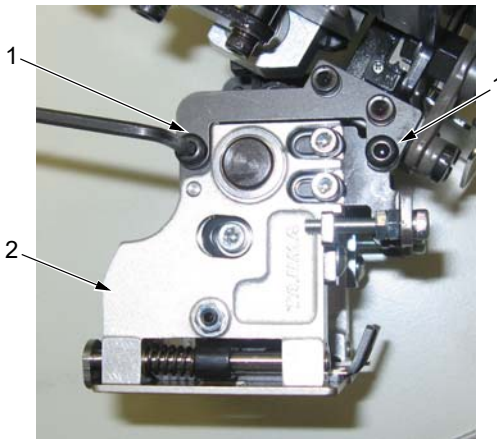
If you want to use different outer diameter sequin, it is necessary to change the sequin guide. There are seven types of sequin guides : for 2, 3, 4, 5, 7, 8 and 9 mm sequin dia. (also for front hole eccentric).

When you use the hexagonal emboss type sequin, it is possible to use the sequin as it is without changing the sequin guide.

When the sequin guide is changed, the cutting position and the needle location are changed. Therefore, adjustment of each part is necessary. (→p.16)

1. Detaching of the lower unit

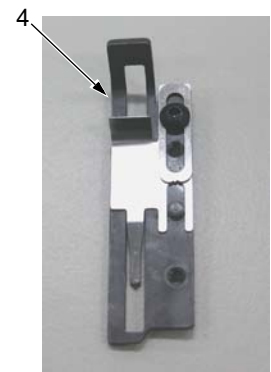
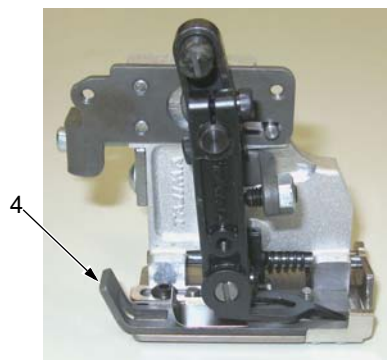
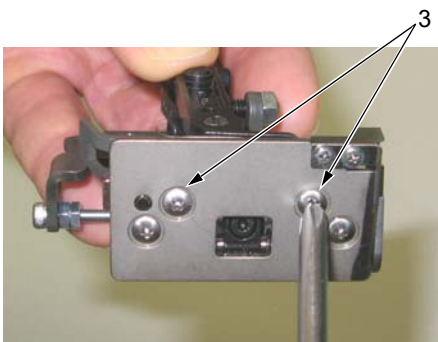
(1) Loosen the stepped screw 1 to be removed and detach the lower unit 2.



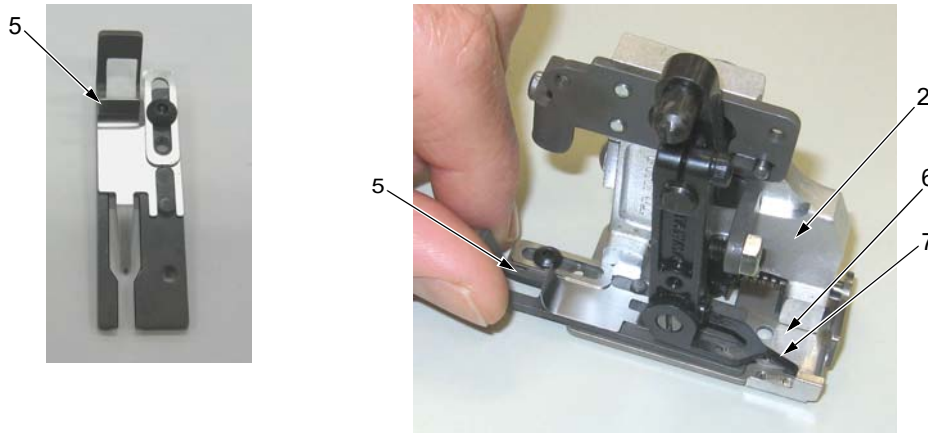
2. Changing example of sequin guide

Here we explain how to change the sequin guide.

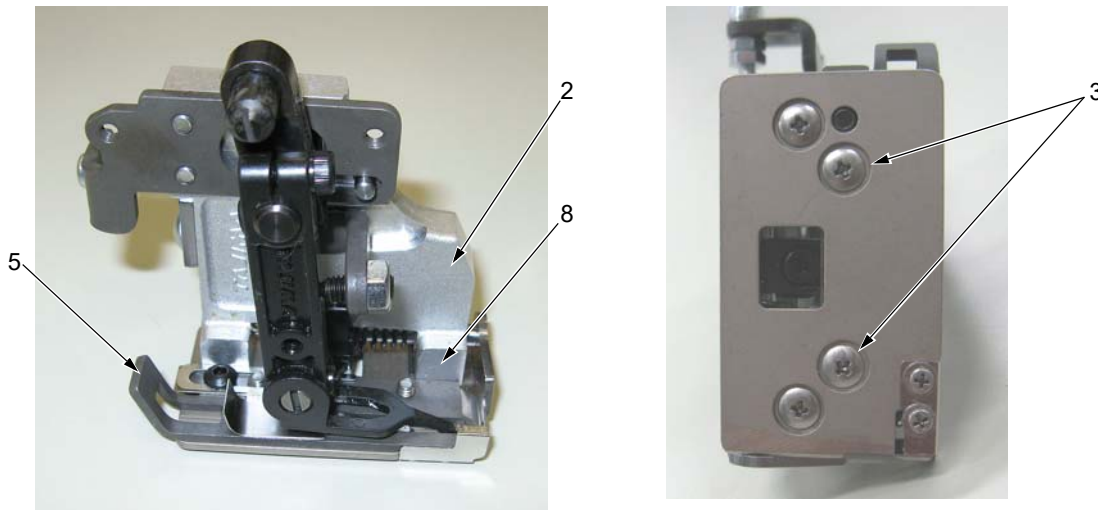
(1) Loosen the screw 3 and detach unused sequin guide 4.



- (2) Attach the sequin guide 5 to use to the lower unit 2, and insert the sequin guide 5 to the rear side in the state of the sequin feed pawl 7 lifted on the fixing knife 6.



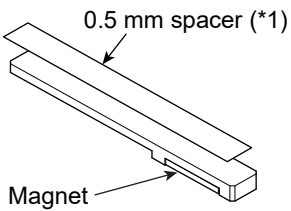

- (3) Tighten screws 3 while touching the side face of the sequin guide 5 to the inner face 8 of the lower unit 2. Attach the sequin guide 5 so that the inner face 8 of the lower unit 2 has no gap.



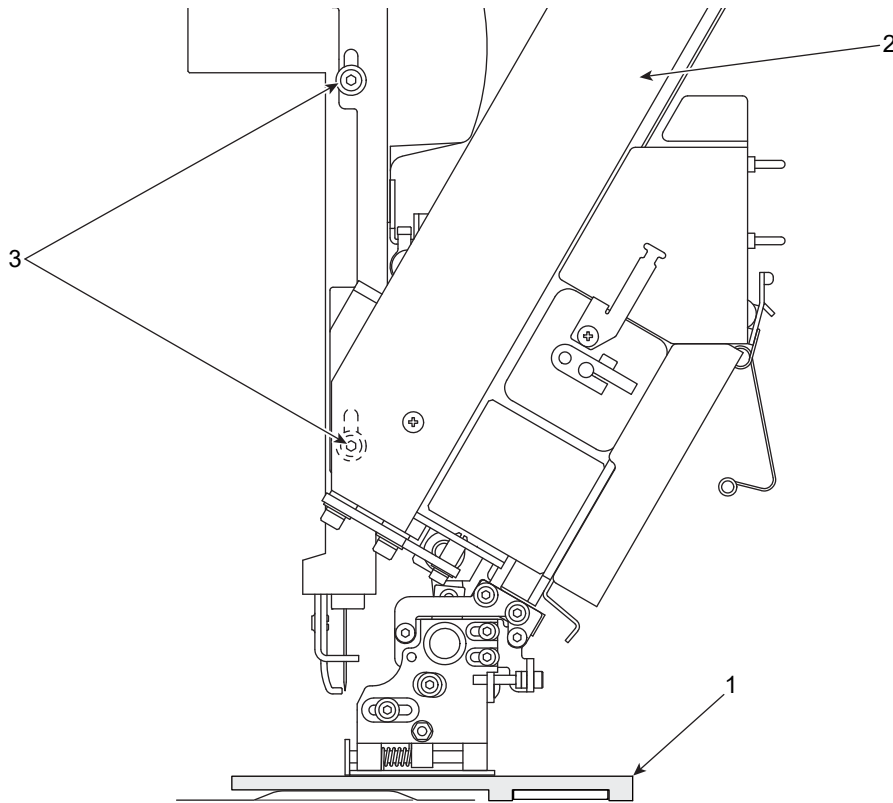
Chapter 5 Adjustment of each part

1. Height of device

To adjust the height, use accessory height gauge.

Height gauge	How to use
 <p>0.5 mm spacer (*1)</p> <p>Magnet</p> <p>(*1) For beads cord unit, add 0.5 mm spacer.</p>	

- (1) Lower the device on the operation panel.
- (2) As shown in the figure below, use the accessory height gauge 1 to check the height from the bottom of the device to the needle plate. When adjustment is necessary, detach the cover 2, and loosen screws 3.

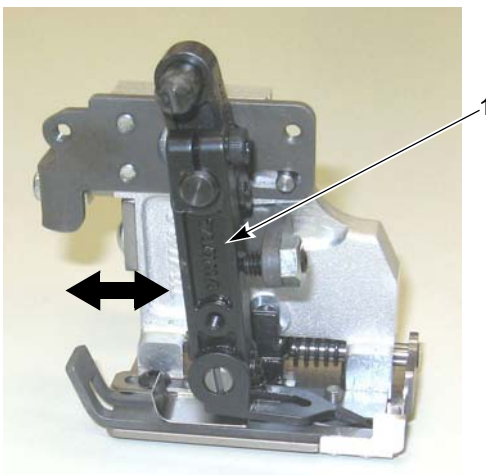


2. Cut position

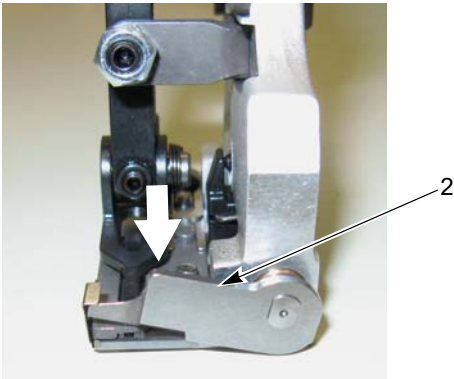
When the sequin guide is changed, the cutting position and the needle location against a sequin hole are changed. Therefore, adjustment is necessary.


Adjust the cutting position in the state of detaching the lower unit at both right and left side. (→p.14)


- (1) Move the sequin lever 1 manually to feed out sequins.



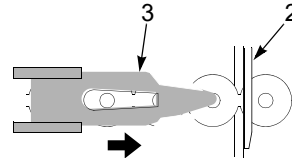
(2) Push the movable knife 2 to cut sequin.




 Correct cutting position

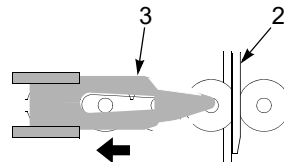
 Bad cut position

Move the sequin feed pawl 3 close to the movable knife 2.

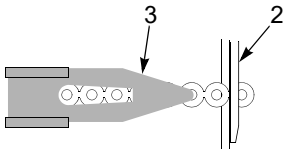


 Bad cut position

Move the sequin feed pawl 3 away from the movable knife 2.

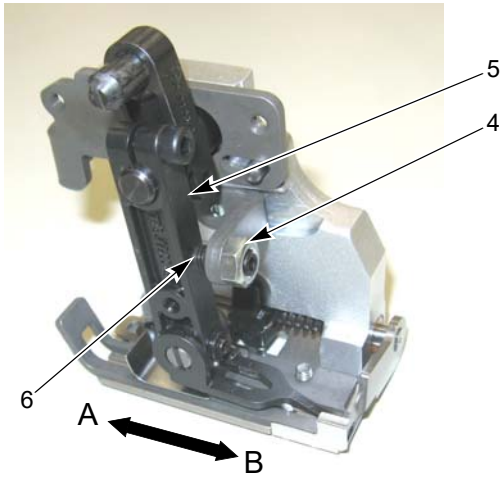


For 2 mm and 3 mm sequin, align the feed pawl 3 with the second sequin from the movable knife 2, and check the cutting position.



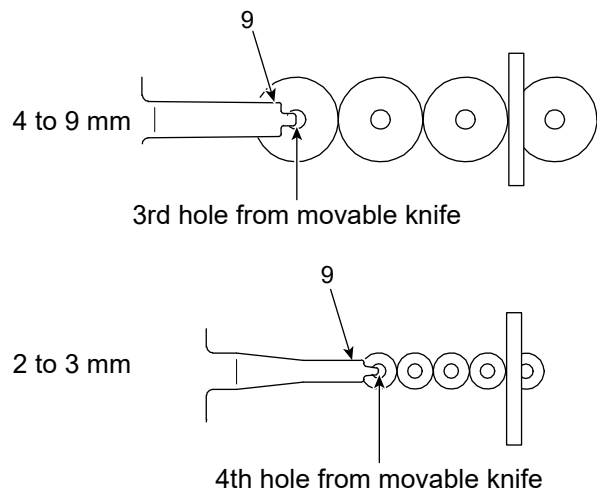
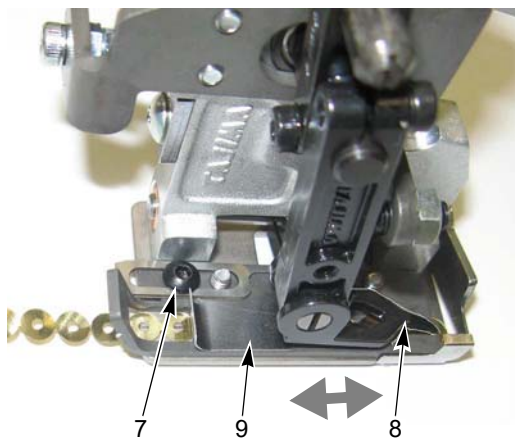
If the cutting position is bad, proceed to the following steps.

- (3) Loosen the nut 4, and adjust the cutting position in the state that the sequin lever 5 is pushed to the adjusting screw 6. Use 2 mm hexagon wrench to adjust the adjusting screw 6. After adjusting, tighten the nut 4.



Cut sequin	Adjusting screw	Position of feed pawl

- (4) Loosen the button screw 7. Adjust the front/back position of the plate spring 9 so that the edge of the plate spring 9 can enter into the center of the sequin hole in the state that the feed pawl 8 enters into the sequin hole.

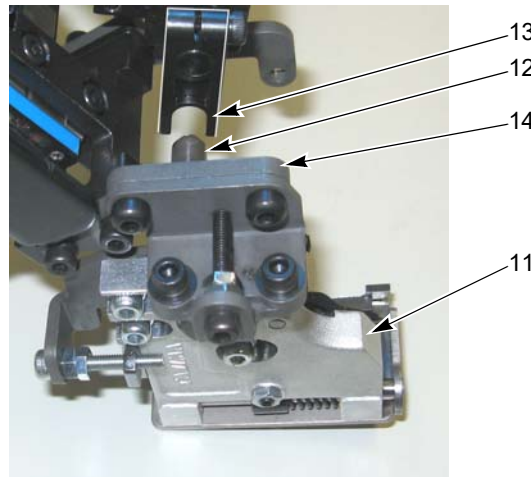


- (5)** Loosen the screw 10 for the sequin lever so that the sequin lever 5 can be adjusted.

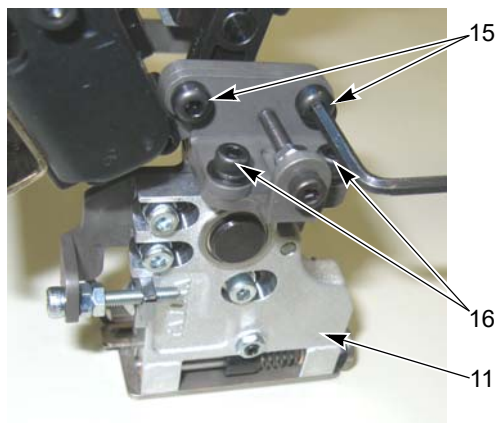


Photo 1

- (6)** Move the lower unit 11 right and left and check if the straight pin 12 enters into the sequin lever 13 securely. Then, attach the lower unit 11 to the sequin base plate 14.



- (7)** Tighten stepped screws 15 to check if the lower unit 11 moves right and left smoothly, then tighten the screw 10 shown in the photo 1 for the sequin lever. If it does not move smoothly, loosen screws 16 to adjust the position of the lower unit 11.

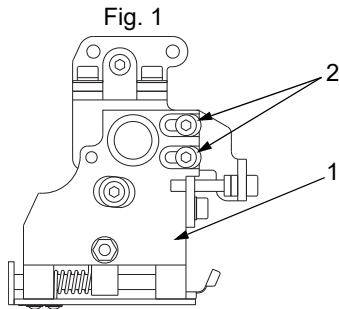


After this, refer to (6) of p.22 to adjust the gap between the sequin lever and the plasticbushing.

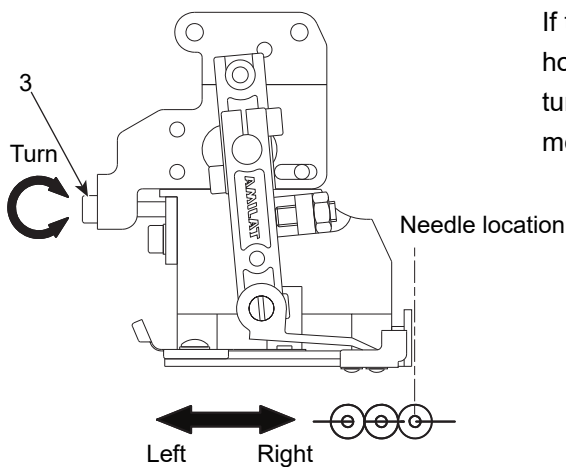
3. Needle locating position (front/rear)

Perform this work after adjusting the sequin cut position and when the needle location is displaced back and forth against the sequin hole.

- (1) Feed out one piece of sequin.
- (2) Perform working in the state that the lower unit 1 is attached to the upper unit.
- (3) Loosen the screw 2.



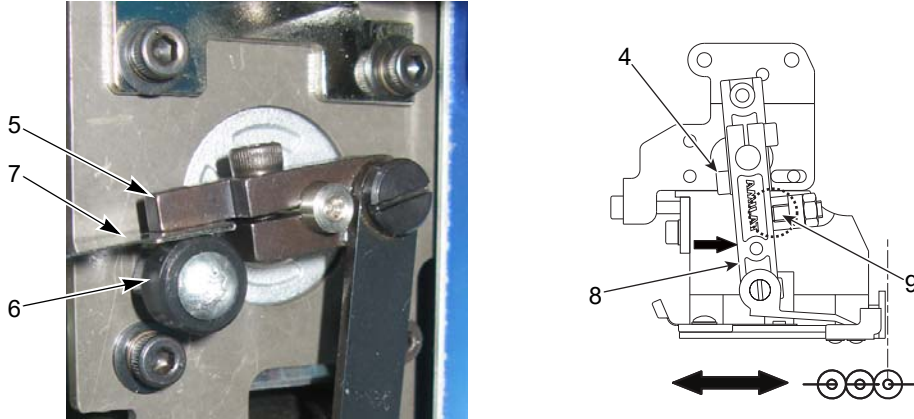
- (4) Adjust the position by turning the position adjusting screw 3 so that the needle locates at the center of the sequin hole while checking the needle position by using the mirror.



If the screw 3 is turned clockwise, the sequin hole will move to the left arrow direction. If it is turned counterclockwise, the sequin hole will move to the right arrow direction.

- (5) After adjustment is finished, tighten screws 2 shown in the figure 1.

- (6) Loosen the screw 4, and insert 0.3 mm spacer 7 (use the sequin-setting tool) between the motor sequin lever 5 and the plastic bushing 6. Then, tighten the screw 4 in the state that the sequin lever is pushed to the adjusting screw 9.



4. Needle locating position (right/left)

Perform this work after adjusting the sequin cut position and when the needle location is displaced right and left against the sequin hole.

- (1) First, set the device to the 1st color by the color change switch 1, and loosen screws 1, 2 and 3.
- (2) Move the lower unit right and left and adjust sequins to the center of needle location.

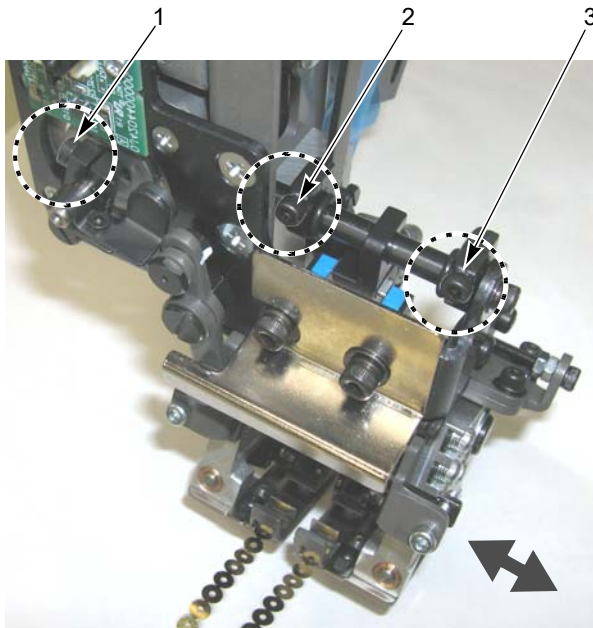
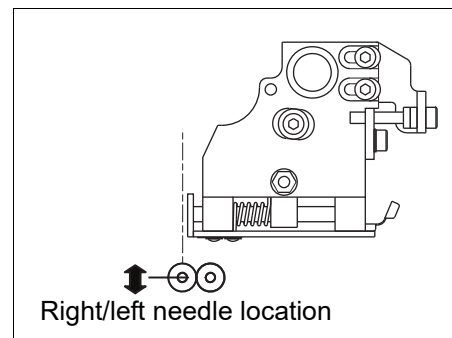
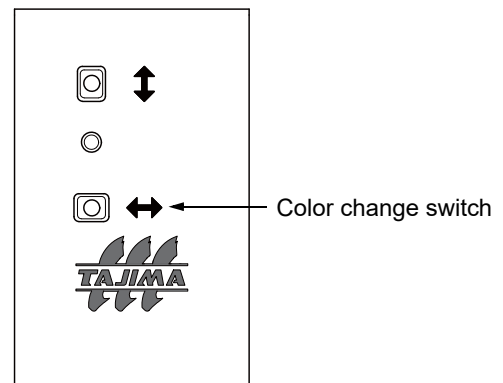
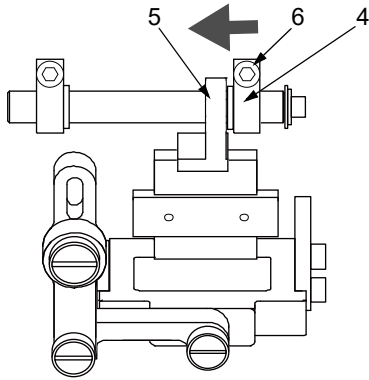


Photo 1

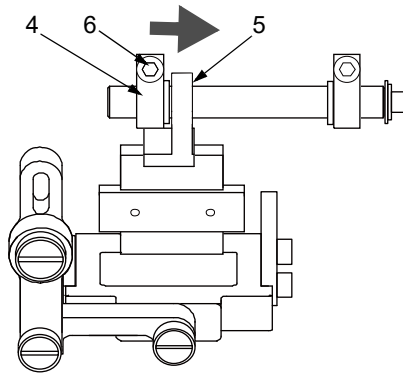


- (3) Touch the stopper 4 to the lower unit base 5 lightly and tighten the screw 6.

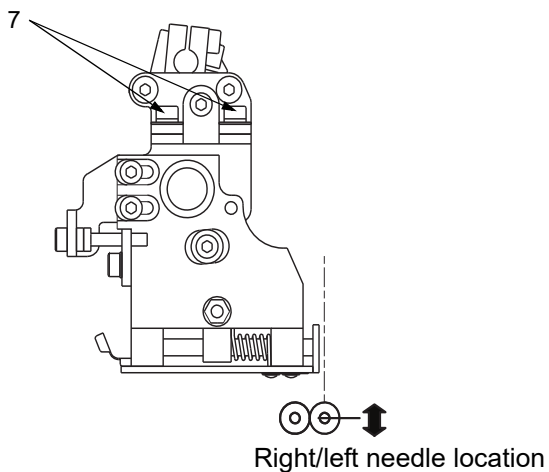


- (4) Set the device to the 2nd color, and tighten the screw 1 shown in the photo 1.

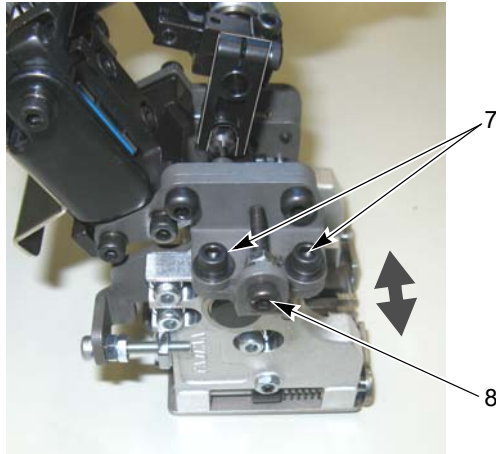
- (5) Set the device to the 1st color by switch operation, touch the stopper 4 to the lower unit base 5 lightly, and tighten the screw 6.



- (6) Loosen screws 7.



- (7) Turn the screw 8 to adjust the needle location, and tighten the screw 7.



- (8) Check if the right and left movement is smooth at the 1st and the 2nd color by switch operation.
- (9) After this, refer to (6) of p.22 to adjust the gap between the sequin lever and the plasticbushing.

Chapter 6 Setting and operation

1. TMAR

1-1. Basic settings

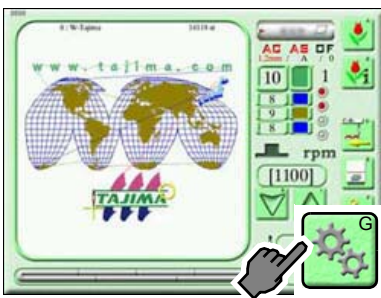
To actuate the device, it is necessary to set the following parameters on the machine side.

When the device is mounted to the right side of the head: Select "1 Sequin device (R)".

When the device is mounted to the left side of the head: Select "2 Sequin device (L)".

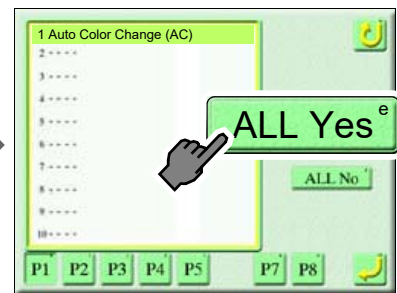
The following explanation is the example when the functional limit level is "1".

(a) Icon G

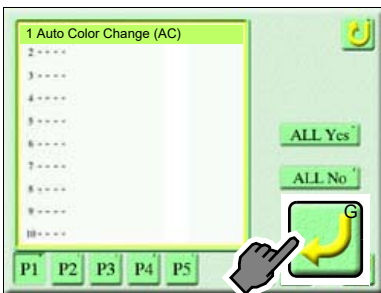


After that, cancel the functional limit level. For details, refer to the chapter for "Parameter" in the user's manual.

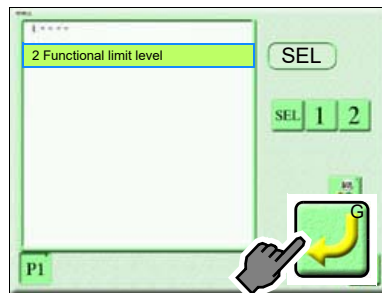
(b) ALL Yes



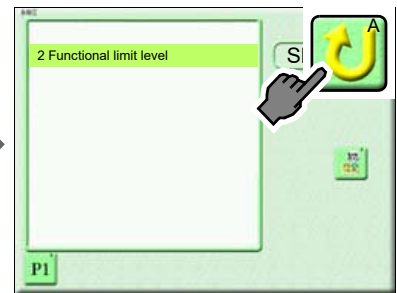
(c) To set



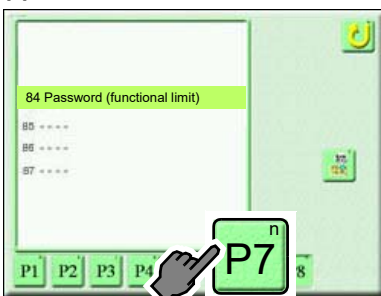
(d) To set



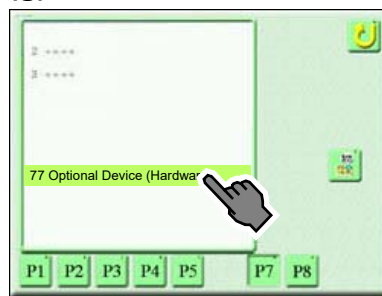
(e) Icon A



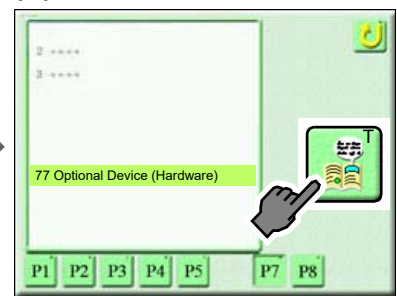
(f) P7



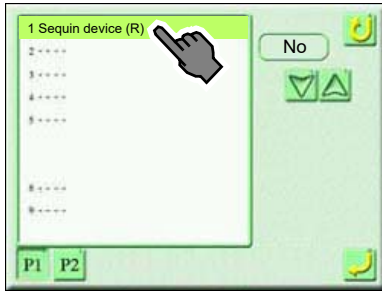
(g) 77 Optional Device (Hardware)



(h) Icon T

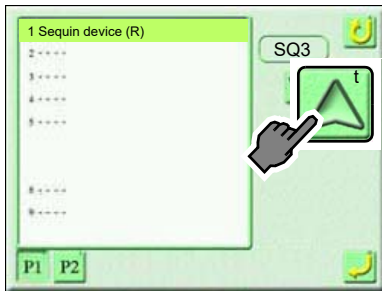


(i) Sequin device (R) or (L)



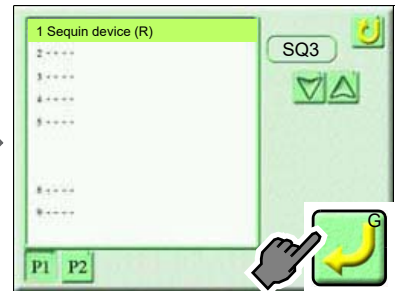
- 1 Sequin device (R):
To equip to the right side
- 2 Sequin device (L):
To equip to the left side

(j) SQ3



- SQ3: Sequin device III
- SQ4: Sequin device IV

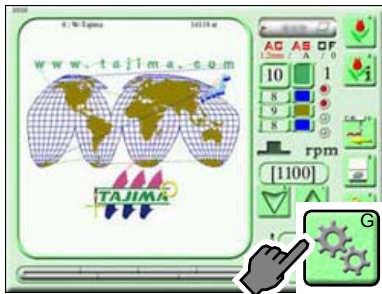
(k) To set



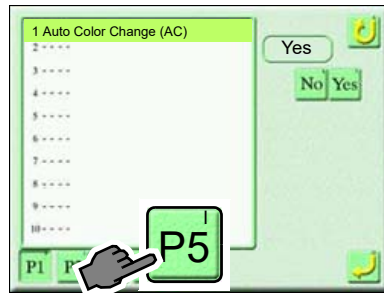
1-2. Setting of sequin chip feed amount

The below explanation is the example of setting the sequin chip feed amount of the 1st color (Sequin 1) for the right side Sequin device.

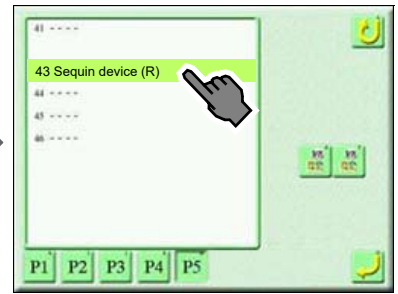
(a) Icon G



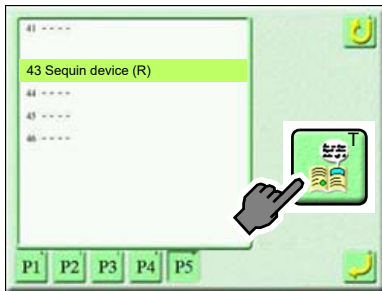
(b) P5



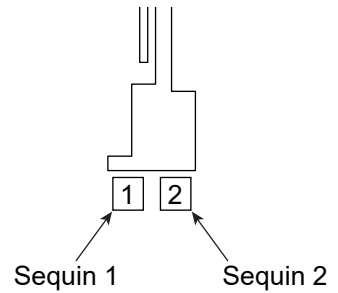
(c) 43 Sequin device (R)



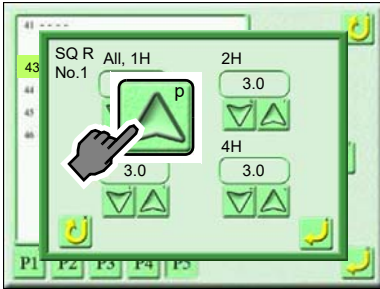
(d) Icon T



-  Sequin 1
-  Sequin 2



(e) Input the value of ALL, 1H



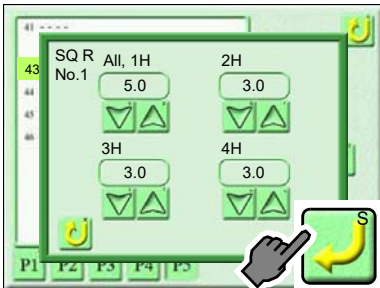
2H, 3H and 4H are not used currently.

Select feed amount according to diameter or material of sequin.

Rough standard of feed amount is as follows.

Outer diameter (mm)	Feed amount
2	3.0
3	4.0
4	5.0
5	6.0
7	8.0
9	9.9

(f) To set



1-3. Insertion of Jump at Sequin

Select whether one stitch of non-data jump code is inserted before or after sequin output or not.

[After output]

Select whether one stitch of non-data jump code is inserted just after sequin feed (output) or not. When you want to tighten thread forcibly after sequin feed, select "Yes". Usually select "No".

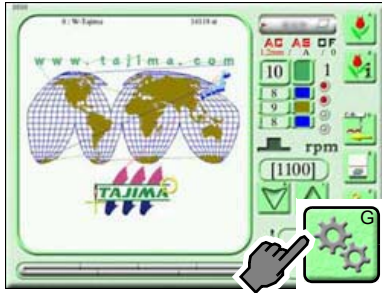
[Before output Y>0]

A non-data code is inserted before sequin feed after sequin color change with the frame movement of +Y direction.

When color changing is overlapped with frame travel of Y-axis data (0.1 mm or more) , select whether one stitch of non-data jump code is inserted or not. If thread breakage is increased depending on design or sewing direction when the movable knife guard is detached (refer to the photo 22 of p.47), select "Yes". This function can insert a non-data jump code to prevent thread breakage.

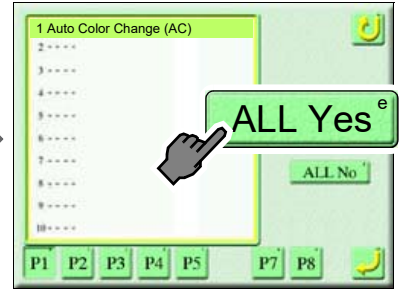
The following explanation is the example when the functional limit level is "1" and "After output" is set to "Yes".

(a) Icon G

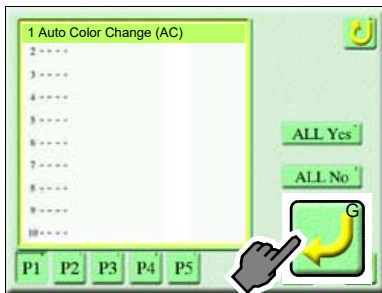


After that, cancel the functional limit level. For details, refer to the chapter for "Parameter" in the user's manual.

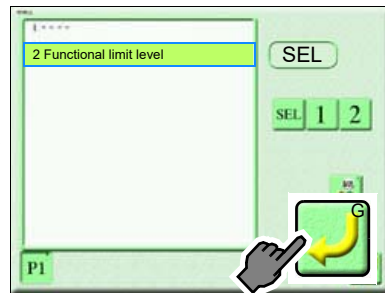
(b) ALL Yes



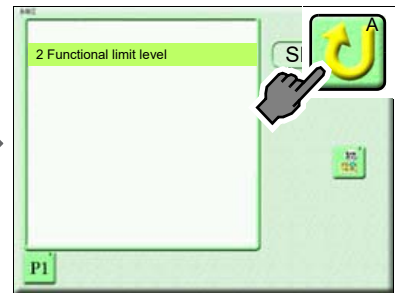
(c) To set



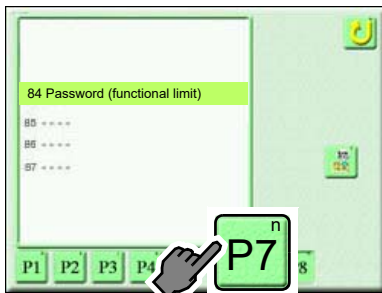
(d) To set



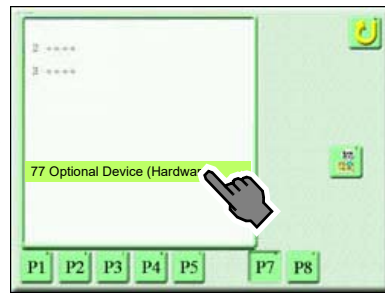
(e) Icon A



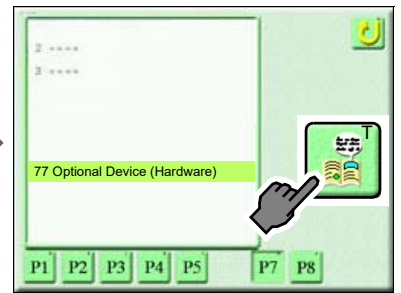
(f) P7



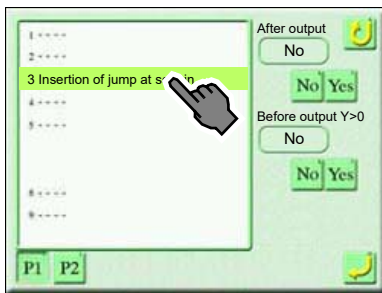
(g) 77 Optional Device (Hardware)



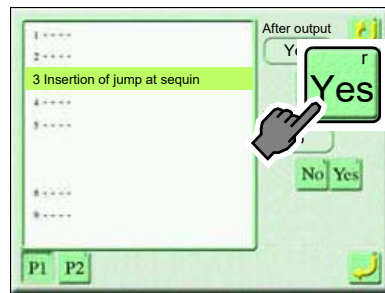
(h) Icon T



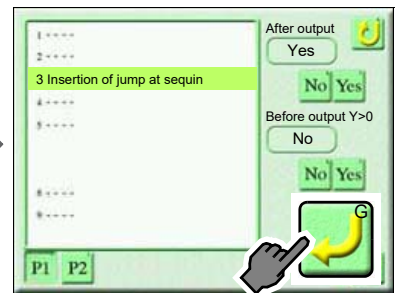
(i) 3 Insertion of jump at sequin



(j) Set "After output" to "Yes"



(k) To set

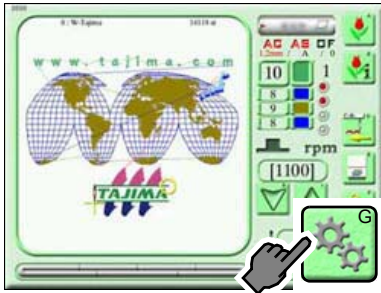


1-4. Auto lifting - Sequin device

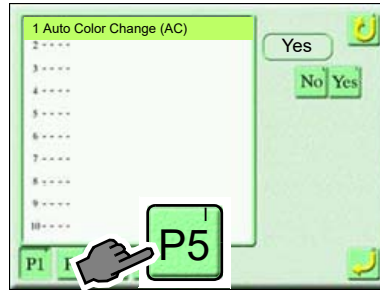
Select whether sequin device moves up automatically at ATH working by frame stepping.

The following explanation is the example of raising the device automatically at ATH working by frame stepping and at thread breakage.

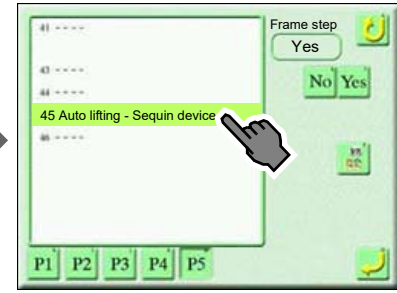
(a) Icon G



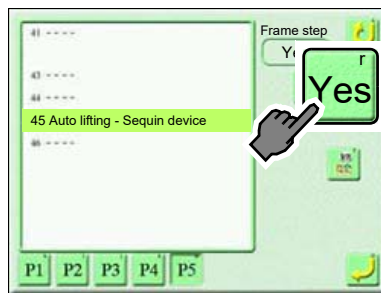
(b) P5



(c) 45 Auto lifting - Sequin device



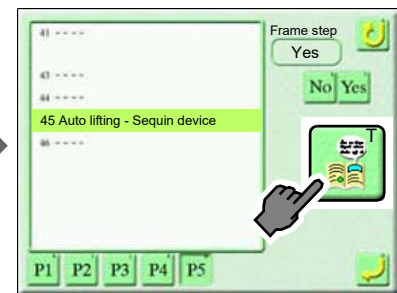
(d) Move up automatically



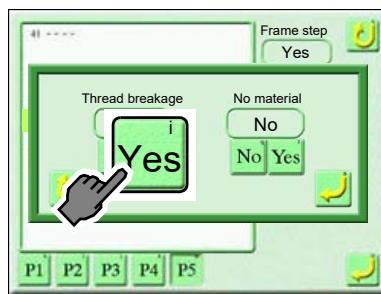
No:
The device stays at the lower dead point during ATH working.(Hook does not work.)

Yes:
The device retracts to the middle point during ATH working.(Hook works.) (Recommended)

(e) Icon T



(f) Yes



Thread breakage

No: Not to raise the device

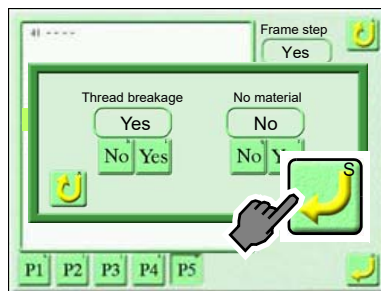
Yes: To raise the device to the upper dead point (Recommended)

No material

No: Not to raise the device

Yes: To raise the device to the middle point (Recommended)

(g) To set



1-5. Sequin chip feed

Performing the setting described below makes possible to feed sequin chips by operation of the tension base switch.

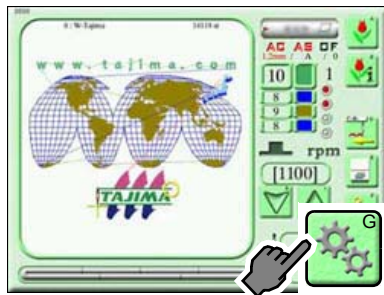
The setting value at “Setting of sequin chip feed amount” will be applied to the sequin feed amount.
(→p.26)

It is not possible to operate the device when color change is not set to the needle side where the device is mounted. R is the 1st needle and L is the last needle.

The following explanation is for the state that the functional limit level is “1”.

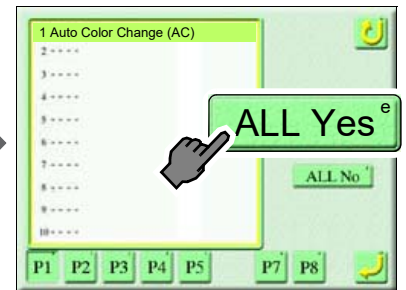
(a) Perform color change to the needle bar side where the device is mounted.

(b) Icon G

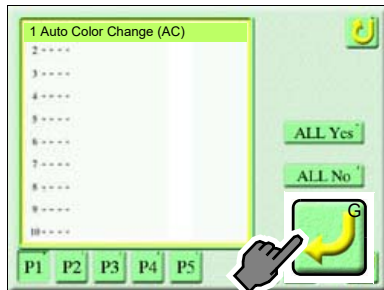


After that, cancel the functional limit level. For details, refer to the chapter for “Parameter” in the user’s manual.

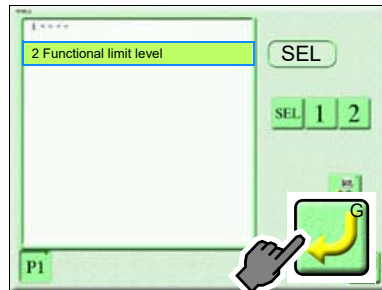
(c) ALL Yes



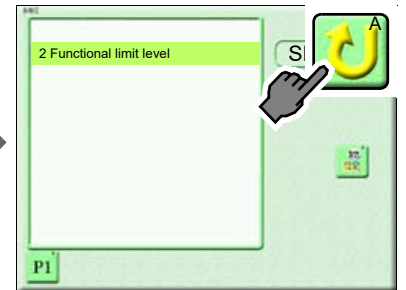
(d) To set



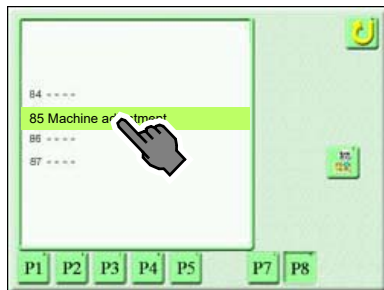
(e) To set



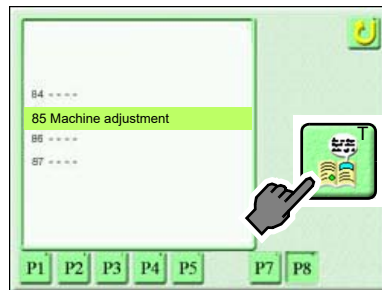
(f) Icon A



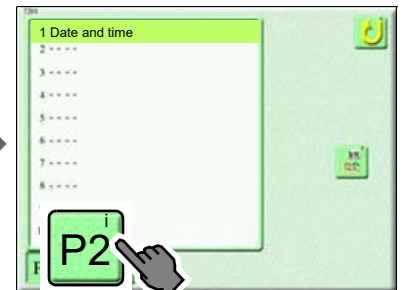
(g) 85 Machine adjustment



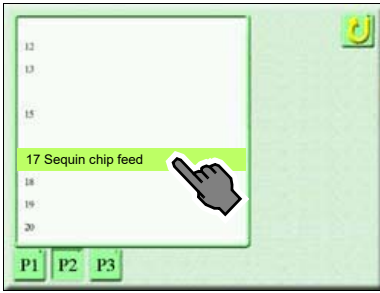
(h) Icon T



(i) P2



(j) 17 Sequin chip feed



(k) Chip Feed



Main shaft angle



Fixed position

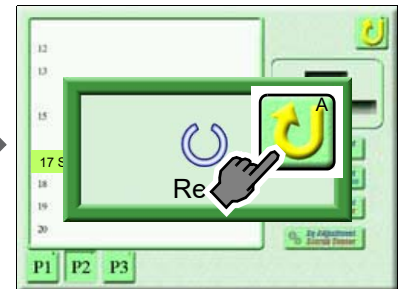


Out of fixed position

(l) Press H switch on the tension base. The sequin chip will be fed out.



(m) Icon A (Completed)



1-6. Moving up/down and color change operation

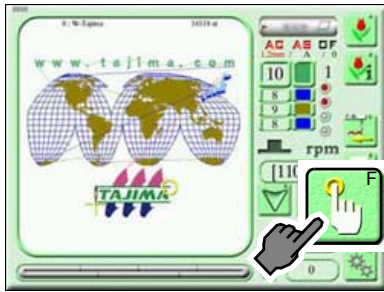
! CAUTION

⊘ When performing this operation, do not put your hands, etc. under the needle or on the machine table. If your hands are under the needle or on the machine table, you could be injured by moving up/down of sequin device.

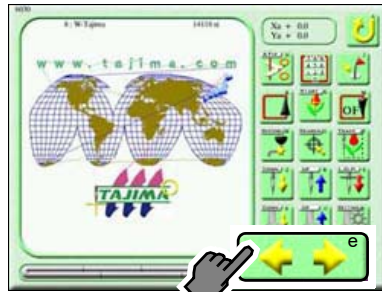
(1) All head operation

Switch to "Manual operation" screen.

(a) Icon F





(b) Icon e

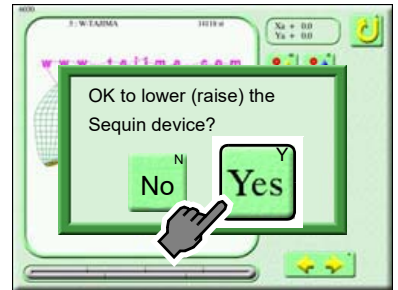


(c) Icon W



-  It will move down.
-  It will move up.

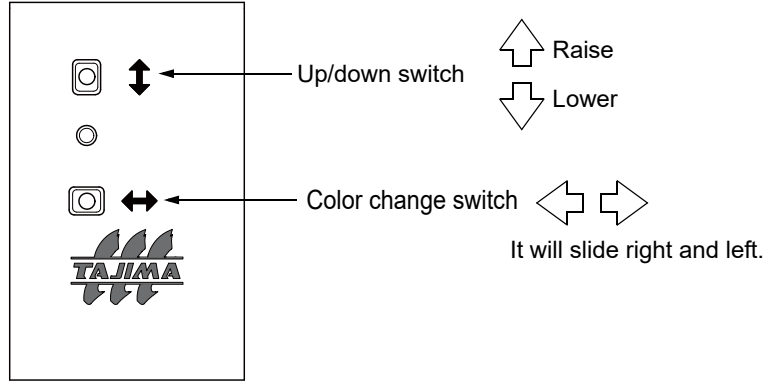
(d) Yes



(2) Individual operation

It is possible to perform independent moving up/down by “Moving up/down switch” and color change operation by “Color change switch” at individual device.

Switch of Sequin device type III



Releasing the moving up/down switch during moving up/down of the device will cause the device to stop at any position.

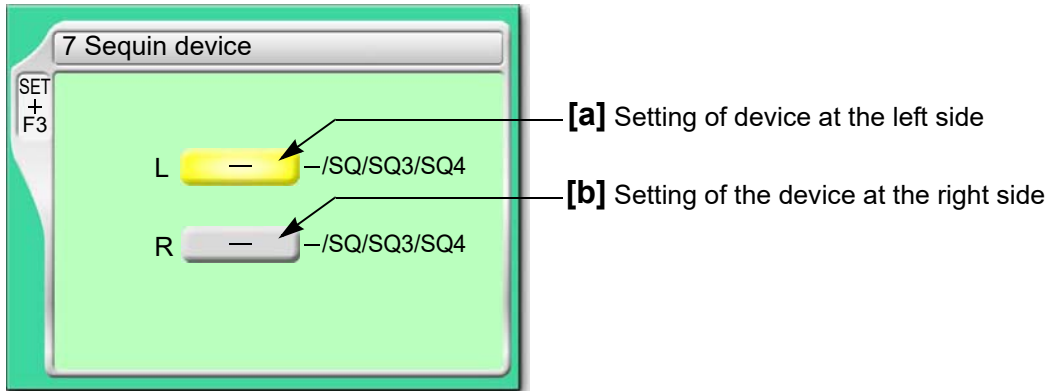
Moving up/down switch and color change switch will not function during operation of the machine. It is possible to perform operation when the machine stops at the fixed position.

2. TFMX, TFMX-C

2-1. Basic settings

This is the setting to make the Sequin device available for use.

(1) Explanation on the screen



[a] Type of Sequin device equipped to left side

—: Not to use the device

SQ: High speed Sequin device

SQ3: Sequin device III (Up/down-by-motor type)

When you select “SQ3” in the single-head machine, the color change speed will become 1/2 of normal speed.

SQ4: Sequin device IV (Up/down-by-air type)

Air compressor is required.

[b] Type of Sequin device equipped to the right side

The contents of settings are the same as [a].

(2) How to operate

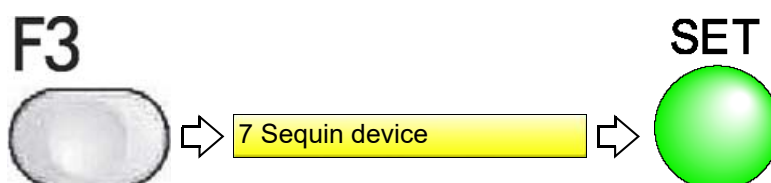
The following is an example of equipping Sequin device III to the left side.

(a) Set to main screen.

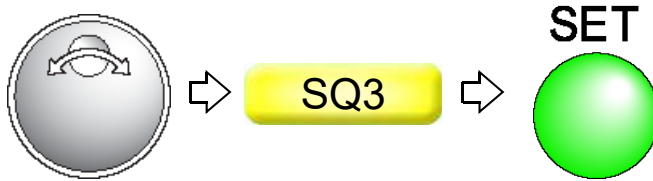
(b) To press F3 key while pressing SET



(c) To press F3 key

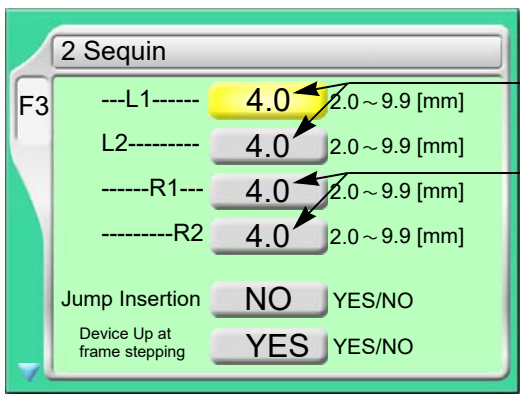


(d) To select type of sequin



2-2. Setting of sequin chip feed amount

(1) Explanation on the screen



[a] Setting of device at the left side

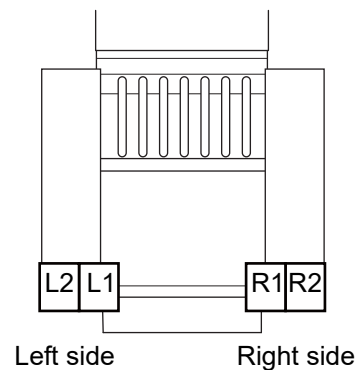
[b] Setting of the device at the right side

[a] Feed amount of sequin chips for each device L1 and L2 at the left side (refer to the right figure)

Select a value that adds about 1.0 to an external diameter of chip as a rough standard.

[b] Feed amount of sequin chips for each device R1 and R2 at the right side (refer to the right figure)

Select a value that adds about 1.0 to an external diameter of chip as a rough standard.

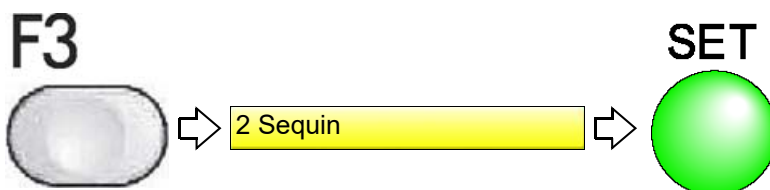


(2) How to operate

The following is the example of setting in the conditions below.

Feed amount of sequin chips of device (L1) at left side: 4.0

(a) To open screen

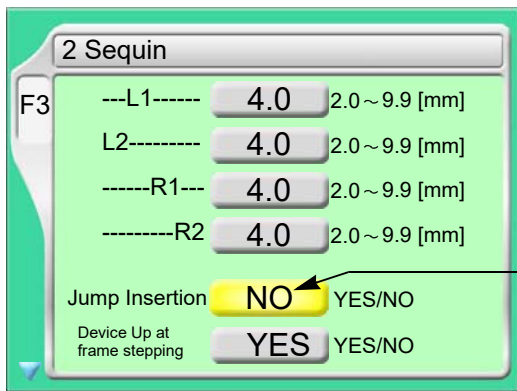


(b) To select feed amount of sequin chips of device (L1) at the left side

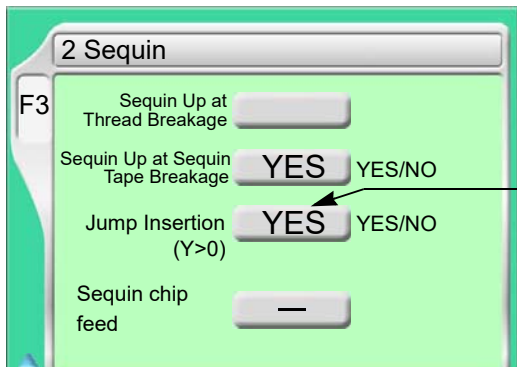


2-3. Insertion of Jump at Sequin

(1) Explanation on the screen



[a] Jump Insertion



[b] Jump insertion (befor output)

[a] Insertion of jump data when a sequin chip is sewn on

Select "YES" when sequin chips are not sewn effectually. However, productivity will be decreased.

YES: To perform

NO: Not to perform

[b] This setting prevents upper thread breakage by interference with device.

YES: To perform

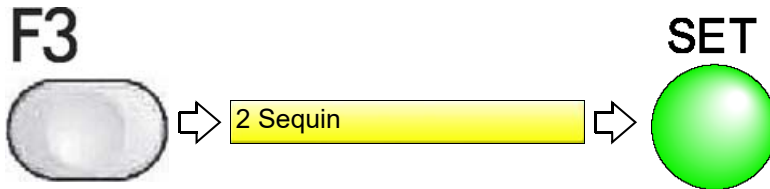
NO: Not to perform

(2) How to operate

The following is the example of setting in the conditions.below.

Insertion of jump data: To perform

(a) To open screen



(b) To move the cursor to "Insertion of jump at sequin".

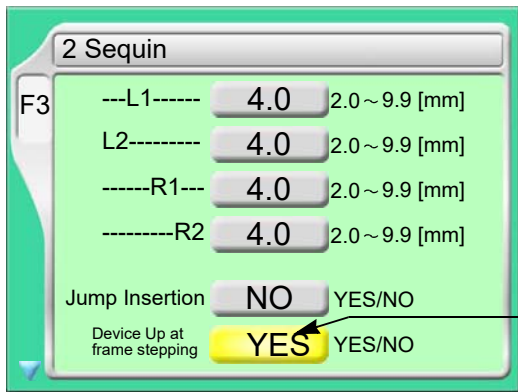


(c) To insert jump data

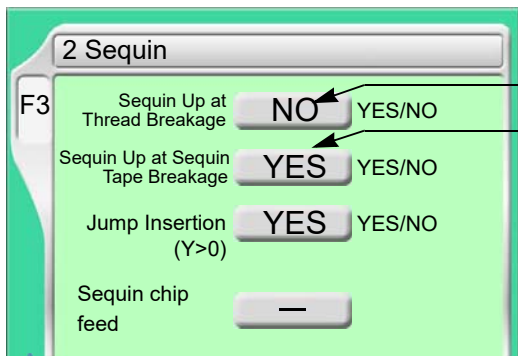


2-4. Auto lifting - Sequin device

(1) Explanation on the screen



[a] Moving up of device



[b] Moving up of device

[c] Moving up of device

[a] Moving up of device at frame stepping

YES: To perform

NO: Not to perform

[b] Moving up of device at thread breakage

YES: To perform

NO: Not to perform

[c] Moving up of device when sequin chip runs out

YES: To perform

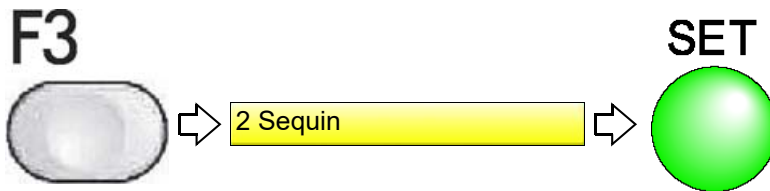
NO: Not to perform

(2) How to operate

The following is the example of setting in the conditions below.

Moving up of device at frame stepping: To perform

(a) To open screen



(b) To move the cursor to "Device Up at frame stepping"

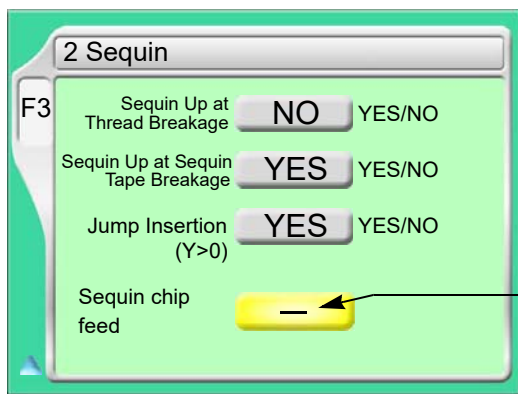


(c) To move up device at frame stepping



2-5. Sequin chip feed

(1) Explanation on the screen




[a] To feed sequin chips one by one

[a] To feed sequin chips one by one

(2) How to operate

CAUTION

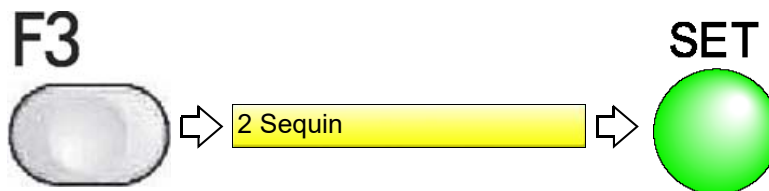
 When performing this operation, do not put your hands etc. near the needle or on the machine table. You could be injured by up/down of the device or moving right and left of the needle bar case.

The following is the example of feeding out sequin chips of the right side Sequin device one by one.

(a) Set the tension base switch to “Middle” position. (It should not be suspended head.)

The single-head machine do not have the tension base switch.

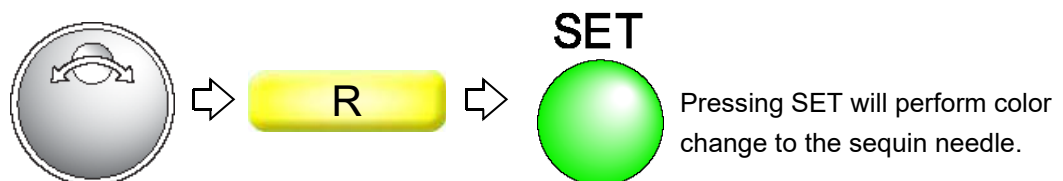
(b) To open screen



(c) To move the cursor to “Sequin chip feed”

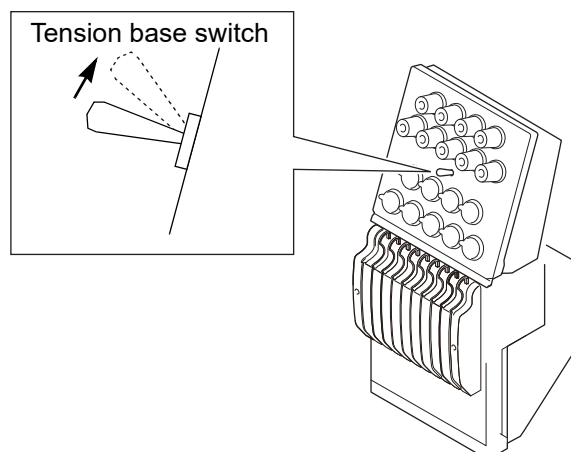


(d) To select R (Right-side Sequin device)



(e) To feed sequin chips

Every time raising the tension base switch will feed out sequin chips one by one.



For the single-head machine, pressing the up-arrow key each time will feed out a sequin chip one by one.



2-6. Moving up/down and color change operation

⚠ CAUTION

⊘ When performing this operation, do not put your hands, etc. under the needle or on the machine table. If your hands are under the needle or on the machine table, you could be injured by moving up/down of sequin device.

(1) All head operation

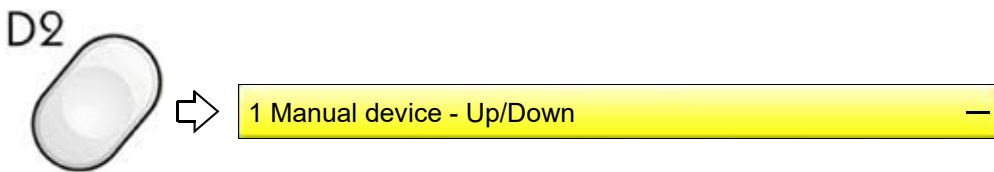
Explanation on the screen

1 Manual device - Up/Down Up

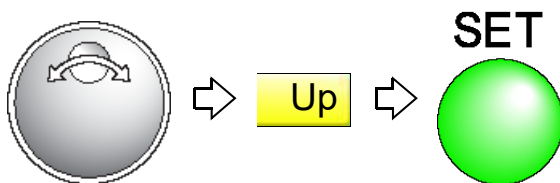
← Up: To lift up
Down: To lower

The below explanation is the example of moving up the Sequin device.

(a) To open screen



(b) To raise the Sequin device



(2) Individual operation

Perform moving up/down and color change of the desired Sequin device individually by manual operation (→p.33)


Chapter 7 Troubleshooting

1. Cause and remedy

Contents of trouble	Cause	Remedy
Sequins are not sewn.	Skip stitching	Adjust the clearance between needle and rotary hook when they meet together to adjust lock stitching.
	Needle does not locate to the center hole of sequin.	Adjust feed position of sequin.
	Movable knife does not return and sequins are clogged.	Clean the section of movable knife for smooth movement.
	R.P.M. is too fast.	Decrease R.P.M.
Cut face is misaligned.	Cut position of sequin is not normal.	Adjust cut position of sequin.
	Unevenness of pitch of sequins	Check pitch of sequins.
Thread breakage	Needle is too thick against the center hole of sequin.	Replace with the regular needle.
	Thread touches movable knife, etc.	Check if thread pass the regular thread course. Clean the section of movable knife for smooth movement.
Misfeeding of sequins	Abrasion of the end section of sequin feed	When you pull sequins to reverse direction and sequins slip to come off, replace the sequin feed.
Sequins are turned over.	The head of the screw at the bottom of the fixed knife turns over sequins.	Follow the countermeasure described later (refer to p.47).

1-1. Error code


(1) Stop by abnormal stop factor

 If a code number of 300 series is displayed, contact your local distributor.

258	Sequin device upper dead point sensor failure	Check/replace the upper dead point sensor.
259	Sequin device lower dead point sensor failure	Check/replace the lower dead point sensor.
25A	Sequin color change sensor failure	Check/replace the sequin color change sensor.
294	Running out of sequin material is detected.	Set the sequin material again.
353	Abnormality in sequin driver card	Check sequin driver card and its connection.
3B8	Communication error of color change sequin	Check sequin controller card and its connection.
3B9	Communication error of sequin driver card	Check sequin driver card and its connection (Occurred only at turning ON the power).

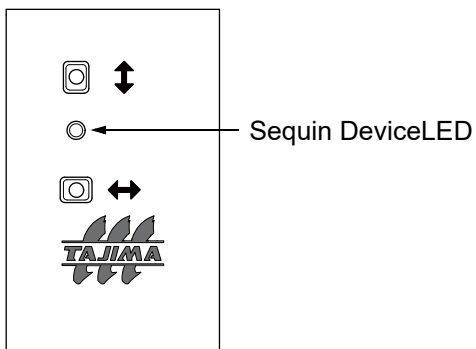
3BA	Communication error of color change sequin	Check sequin controller card and its connection (Occurred only at turning ON the power).
5C2	Operation was performed during moving up/down of the Sequin device.	Do not start the machine during up/down of the device.
5C3	Sequin wrong setting	Check if parameter setting (TMAR), panel setting(TFMX) are correctly performed.

(2) Stop due to usual stop factor

 Stop by the code numbers described below is not caused by occurrence of error.

1C4	Stop due to setting position of tension base switch from bottom to top during operation	Start the machine to continue embroidery.
-----	---	---

1-2. LED display



Type	LED display	
	Corresponding head	Other heads than the corresponding head
Upper thread breakage	Lit	Unlit
Under thread breakage	Lit	Unlit
Running out of material (option)	Blinking	Unlit

1-3. Up/down motion at frame back

(1) Frame Back

When you start frame back irrespective of frame back method, up/down position will become as shown in the table below.

Head	Up/down position
Head with thread breakage	Upper dead point (or middle point)
Heads without thread breakage	Middle point



Middle point is the position of the device when setting “makes the device not to move up” in parameter 45 (TMAR) or panel setting (TFMX).



Regarding frame back, refer to the user’s manual of the machine.



Regarding upper dead point, middle point, lower dead point, refer to p.5.

(2) Movement at the beginning of repair stitches

At the head with thread breakage, the machine will start embroidery after the device moves down to the lower dead point.

At the head without thread breakage, the up/down position of the device will be left at the middle point.

(3) Movement at the start of all head sewing

The embroidery machine will once stop, and the embroidery will start after devices of all heads move down to the lower dead point.

1-4. When sequins are turned over

Sequins may be turned over by the head of screw positioned at the bottom of the fixed knife of the device according to design, shape of sequin and sewing direction, which has a disadvantage for embroidery. In this case, manage the problem with the following procedure.

- (1) Remove the screw and washer of the front side where sequins turn over (1st color or 2nd color).

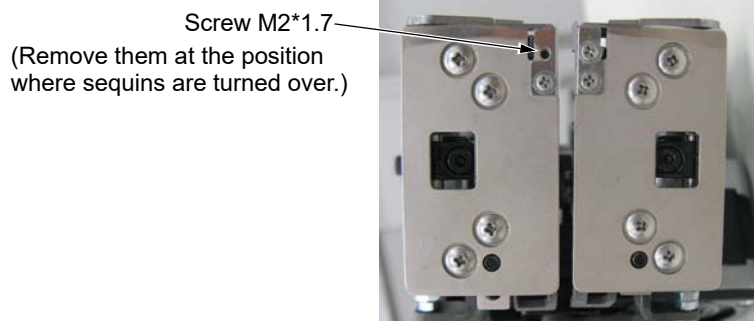


Photo 20

- (2) If the problem is not resolved yet even by the method described above, remove another screw and washer.

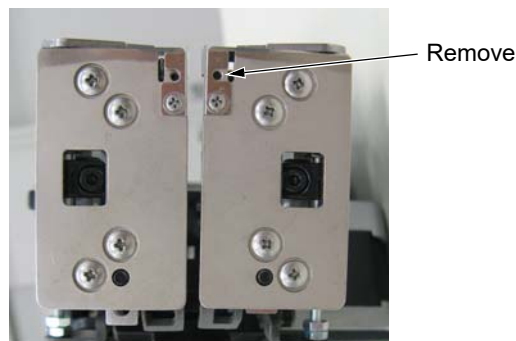


Photo 21

- (3) If the method (2) described above still does not solve the problem, detach the movable knife guard at the position where sequins are turned over.

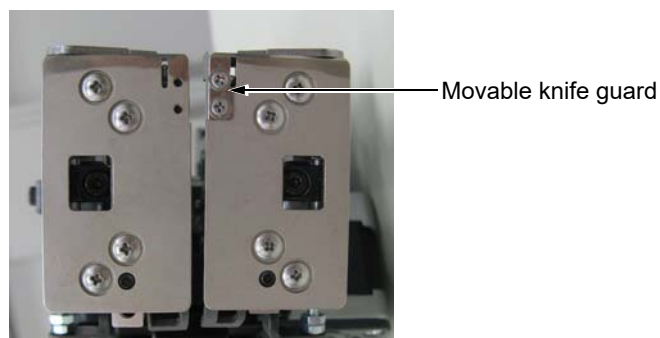


Photo 22

(4) When thread breakage is increased by the method described above

(a) TFMX

Set “Jump insertion → No”, “Jump insertion Y>0 → Yes” by panel setting (→p.36).

(b) TMAR

Set “After output → No”, “Before output Y>0 → Yes” by panel setting (→p.27).

2. Lubrication and greasing

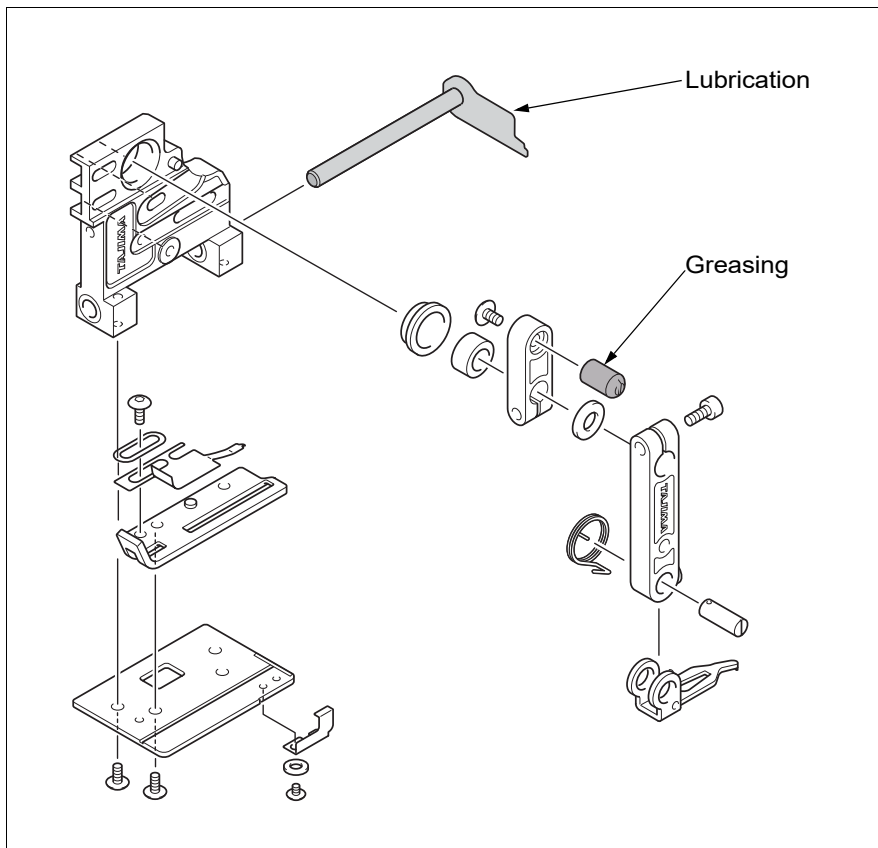
! WARNING

- ! When you perform lubrication or greasing, turn OFF the power switch. You could be injured by moving machine.

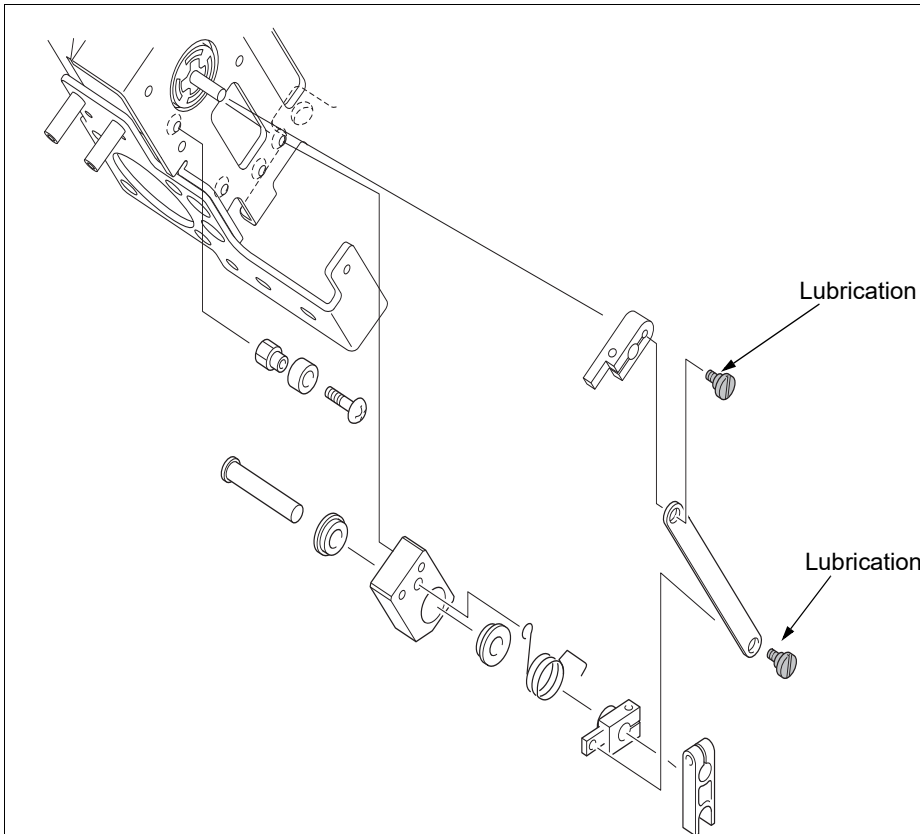
! CAUTION

- ! Perform lubrication once per month and greasing once per six months.
- ! Keep the determined lubricating or greasing cycle strictly. If not, mis-cutting could occur or abrasion of parts could become faster.
- ! When performing lubrication, use only Tajima's genuine TF oil or equivalent (ISO viscosity grade=VG20).
- ! When performing greasing, consult the distributor.
- ! When performing greasing, use Tajima's genuine PG grease or the recommended goods (synthetic oil-based lithium grease) or equivalent.

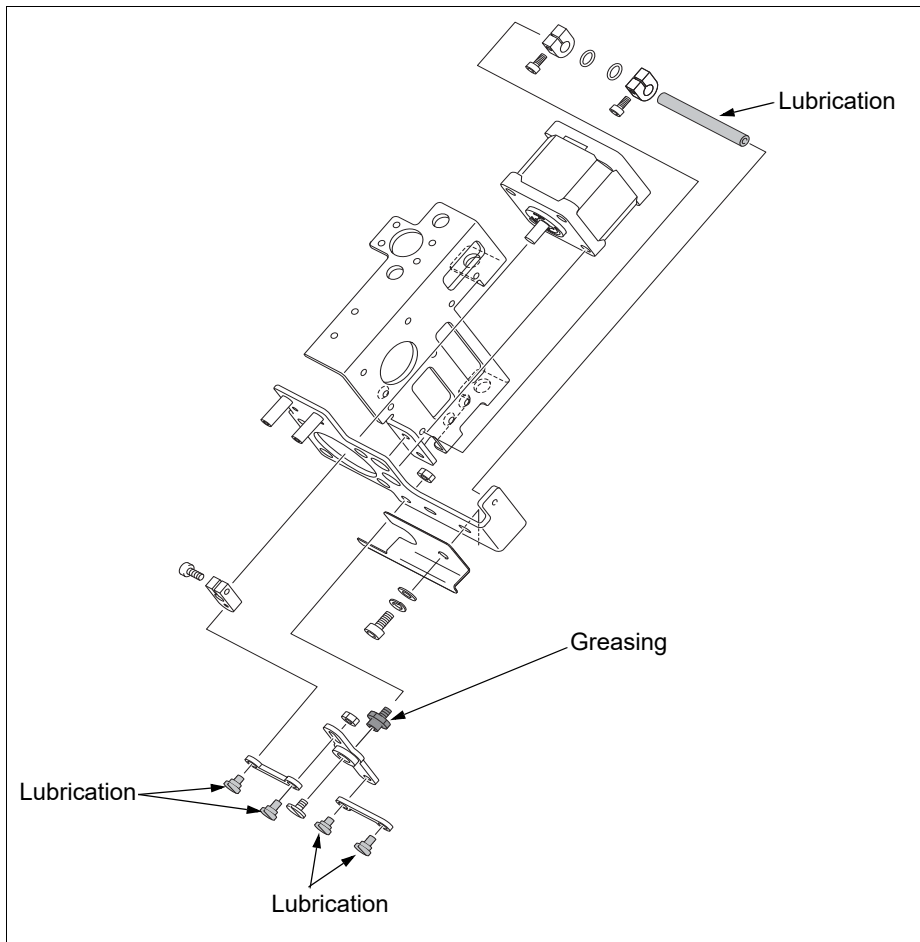
(1) Sequin lower unit



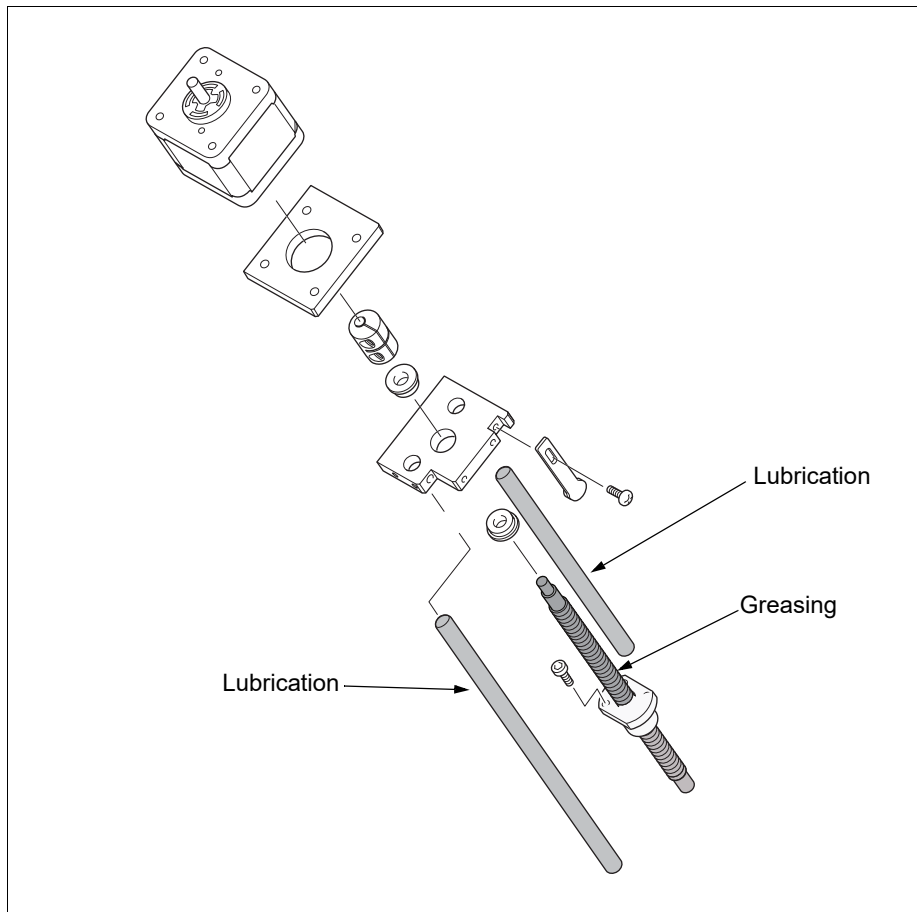
(2) Sequin feed section



(3) Sequin switching section



(4) Moving up/down section



1st Edition March, 2010

20th Edition October, 2019

■ **Manufactured by : TISM Co.,Ltd.**

Address : NO.1800, Ushiyama-cho, Kasugai, Aichi-pref., 486-0901, Japan

TEL : 81-568-33-1161 FAX : 81-568-33-1191

■ **Distributed by : Tajima Industries Ltd.**

Address : NO.1800, Ushiyama-cho, Kasugai, Aichi-pref., 486-0901, Japan

TEL : 81-568-37-1130 FAX : 81-568-37-1230

●**Copy, reprint, or reform of a part or whole of this manual without permission is prohibited.**