



Optional Device Manual

Sequin Device IV

Foreword

This user's manual describes about the correct using method and instructions for use of this product. Please use this machine after understanding the contents of the manual.

This manual may contain discrepancies in detailed specification as compared with the actual production. If you have any question about this manual, consult your TAJIMA distributor.

We believe that "BASICS" of TAJIMA EMBROIDERY MACHINES and "MACHINE SETUP INSTRUCTIONS" are useful to deepen your knowledge about this product. Please also read those booklets.

Regarding how to handle the products related, refer to the user's manual exclusive for them included in the manual CD.

TISM Co.,Ltd.

SAFETY PRECAUTIONS

To prevent any harm or damage to the person who use this product or other person, we describe items that must be surely followed as below.



Indicates that there is a lot of danger of death or serious injuries [*1] if handled by mistake.



Indicates that there is a likelihood of death or serious injuries [*1] if handled by mistake.





Indicates a potentially hazardous situation which may result in minor or moderate injury [*2] or property damage if handled by mistake.

*1: A condition caused by electric shock, injury, fracture of a bone, etc., that leads to aftereffects, or an injury that necessitates hospitalization or visits to a hospital over a long period.

*2: An injury that does not necessitate hospitalization or visit to a hospital over a long period.

: Prohibited items

: Items that may cause electric shock if not observed

: Items that must be followed carefully to ensure safe operation

Chapter 1 Outline of the device

1.	Instructions for use	7
2.	Name of each part	8
2-1.	Device main body	8
2-2.	Standard lower unit (standard spec.).....	9
2-3.	Wide range lower unit (wide range spec.)	9
3.	Sequin size	10
3-1.	Standard specification (2 - 9 mm).....	10
3-2.	Wide range spec. (10 to 22 mm sequin).....	10

Chapter 2 Before using device

1.	Setting of sequin	11
2.	Sequin guide (standard spec.).....	13
2-1.	Type of sequin guide	13
2-2.	Replacement of sequin guide	14
3.	Movable knife guide (wide range spec.)	15
3-1.	Type of movable knife guide.....	15
3-2.	Replacement of movable knife guide	15
4.	Mounting position of motor bracket.....	16
5.	Adjustment of each part.....	17
5-1.	Height of device	17
5-2.	Cut face	19
5-3.	Front-to-back adjustment of sequin plate spring	21
5-4.	Adjustment of needle location	22
6.	Up/down speed.....	23
6-1.	Air check.....	23
6-2.	Adjustment of speed controller	24
7.	To raise the devices individually.....	25

Chapter 3 TMCR, TMAR, TMBR2, TMBU2

1.	Standard spec.	27
1-1.	2 to 9 mm sequin	27
2.	Wide range spec.....	29
2-1.	For 10 to 22 mm dead center sequin.....	29
2-2.	11 to 22 mm front hole eccentric sequin.....	29
3.	Setting and operation (TMCR, TMAR)	30
3-1.	Cancellation of Functional Limit Level	30
3-2.	Basic settings	31
3-3.	Setting of Air compressor	32
3-4.	Setting of sequin chip feed amount	32
3-5.	Insertion of Jump at Sequin	33
3-6.	Auto lifting - Sequin device	34
3-7.	Sequin chip feed.....	34
3-8.	To raise/lower Sequin device at all heads together in a batch	36
4.	Replacement of parts (from standard spec. to wide range spec.).....	37
4-1.	Replacement of parts near needle	37
4-2.	Replacement of lower unit parts	40
5.	Replacement of parts (from wide range spec. to standard spec.).....	41
5-1.	Replacement of parts near needle	41
5-2.	Replacement of lower unit parts	44

Chapter 4 TMCP, TMCS, TFMX, TWMX-C, TMBP2, TLMX, TCMX

1.	Standard spec.	45
1-1.	2 to 9 mm sequin	45
2.	Wide range spec.....	47
2-1.	10 to 22 mm sequin	47
3.	Setting and operation (TFMX, TFMX-C, TWMX-C, TLMX, TCMX).....	48
3-1.	Basic settings	48
3-2.	Setting of Air compressor	50
3-3.	Setting of sequin chip feed amount	51
3-4.	Sequin chip feed.....	53
3-5.	To raise/lower Sequin device at all heads together in a batch	55

4.	Setting and operation (TMCP, TMCS).....	56
4-1.	Basic settings	56
4-2.	Setting of Air compressor	56
4-3.	Setting of sequin chip feed amount	56
4-4.	Insertion of Jump at Sequin	56
4-5.	Auto lifting - Sequin device	56
4-6.	Sequin chip feed.....	56
4-7.	To raise/lower Sequin device at all heads together in a batch	56
5.	Setting and operation (TMBP2).....	57
5-1.	Basic settings	57
5-2.	Setting of Air compressor	57
5-3.	Setting of sequin chip feed amount	57
5-4.	Insertion of Jump at Sequin.....	57
5-5.	Auto lifting - Sequin device	57
5-6.	Sequin chip feed.....	57
5-7.	Up/down operation	57
6.	Replacement of parts (from standard spec. to wide range spec.)	58
6-1.	Replacement of parts near needle	58
6-2.	Replacement of lower unit parts	61
7.	Replacement of parts (from wide range spec. to standard spec.)	62
7-1.	Replacement of parts near needle	62
7-2.	Replacement of lower unit parts	66

Chapter 5 Maintenance

1.	Cleaning	67
2.	Lubrication	68

Chapter 1 Outline of the device

1. Instructions for use

CAUTION

 Do not move up/down the air cylinder and its relative parts by hand forcedly.
The device will be damaged.

 You could be burnt by high temperature. Pay attention when you touch the pulse motor by hand.

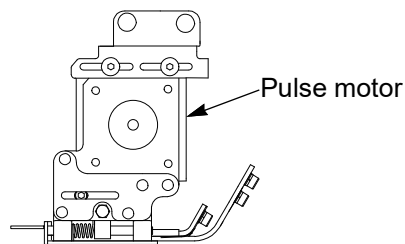

 When you perform threading, replacement of material (Sequin) or other adjustment, pay attention to the protruding parts of the device because your face or head comes in contact with the protruding parts and you could be injured.

2. Name of each part

2-1. Device main body

1. Sequin reel
2. Air cylinder
3. Speed controller (→p.24)
4. Sequin roller
5. Finger valve (→p.25)
Not equipped in single head machine
6. Clutch lever (→p.25)
7. Slide rail
8. Pulse motor
9. Sequin lever
10. Lower unit (→p.9)

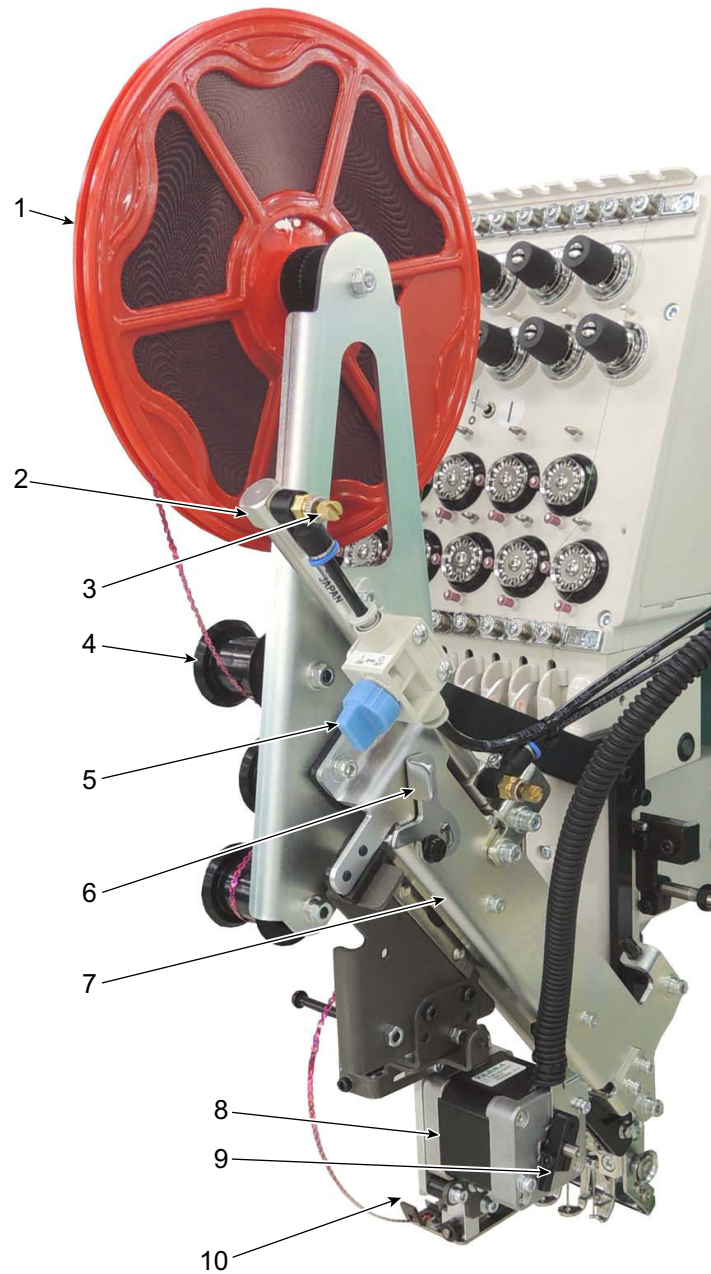

2-2. Standard lower unit (standard spec.)

The standard lower unit corresponds to the following sequins.

- 2 to 9 mm dead center sequin (→p.10)
- 9 mm or less special-shaped sequin (→p.10)

1. Movable knife
2. Movable knife guard
3. Sequin feed
4. Sequin plate spring
5. Sequin guide

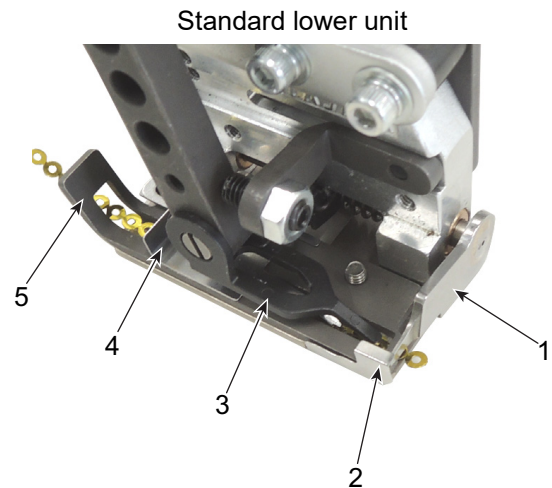

2-3. Wide range lower unit (wide range spec.)

The wide range lower unit corresponds to the following sequin.

- For 10 to 22 mm dead center sequin (→p.10)
- 11 to 22 mm front hole eccentric sequin (→p.10)

1. Movable knife
2. Movable knife guard
3. Sequin feed
4. Sequin plate spring
5. Sequin guide
6. Movable knife guide

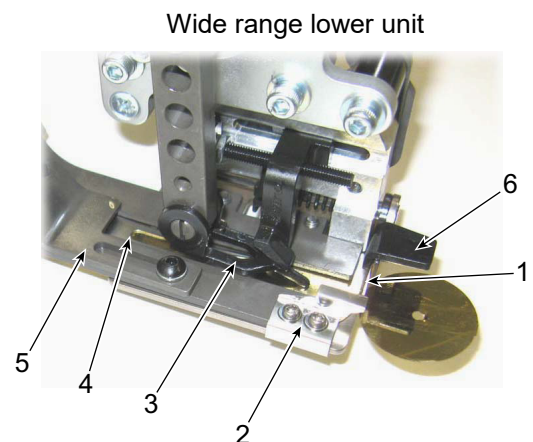

3. Sequin size

Sequins have various shapes and sizes depending on the application.

This document explains about the example of the following sequin. Please ask the distributor for details.

3-1. Standard specification (2 - 9 mm)

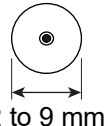
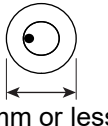
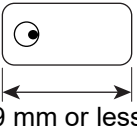
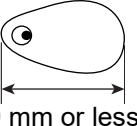
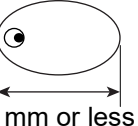
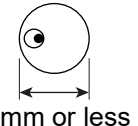
2 to 9 mm sequin					
2 to 9 mm dead center sequin	9 mm or less special-shaped sequin				
	Ring	Strip	Tear drop	Ellipse	Front hole eccentric
 2 to 9 mm	 9 mm or less	 9 mm or less	 9 mm or less	 9 mm or less	 9 mm or less

3-2. Wide range spec. (10 to 22 mm sequin)

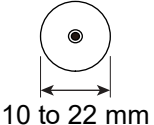
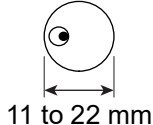
10 to 22 mm sequin	
For 10 to 22 mm dead center sequin	11 to 22 mm front hole eccentric sequin
 10 to 22 mm	 11 to 22 mm

Chapter 2 Before using device

1. Setting of sequin

Referring to the photos below (standard spec.), pass sequins through each part.

The method to pass sequins is the same for wide range spec.

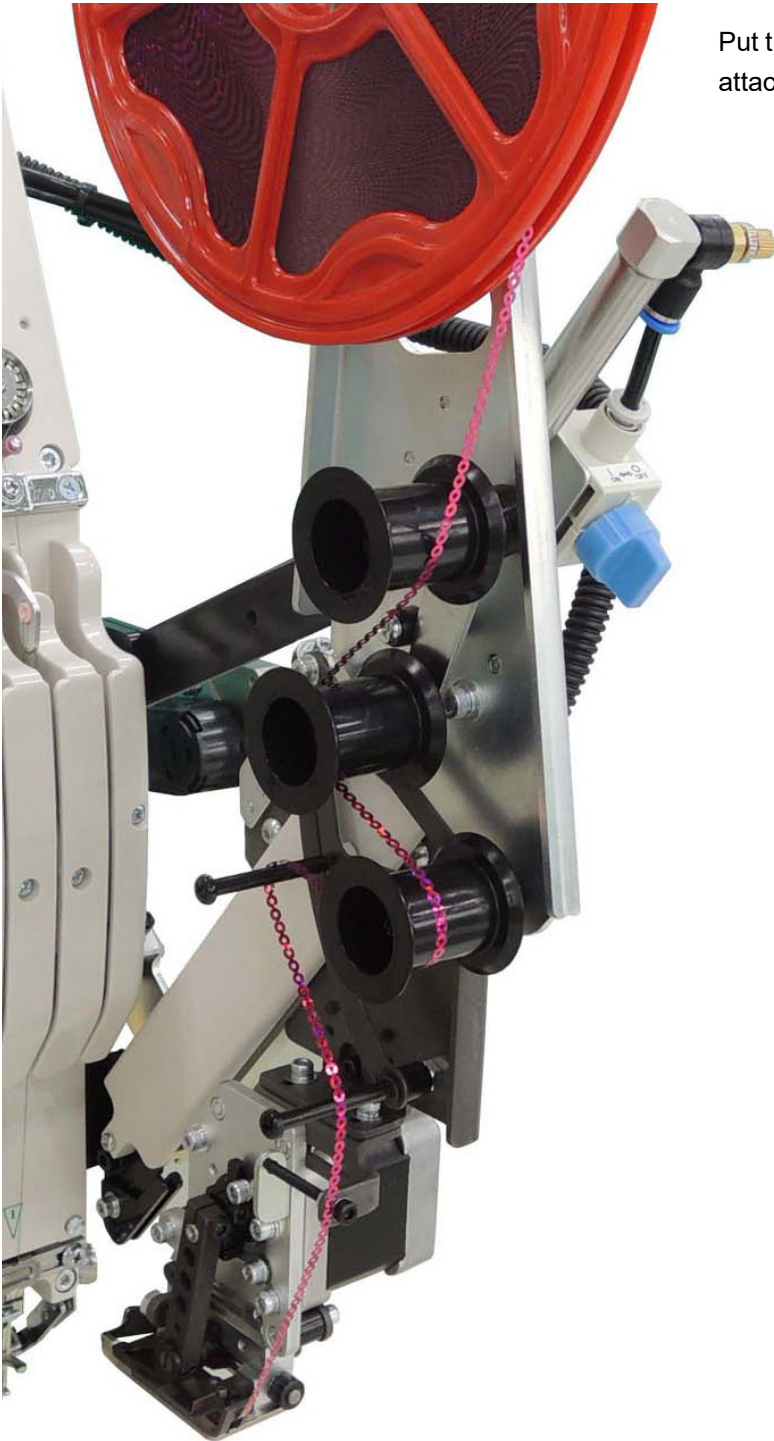

Put the sequin reel 1 on the screw with pin 2, and attach the felt 3 and the split collar 4.

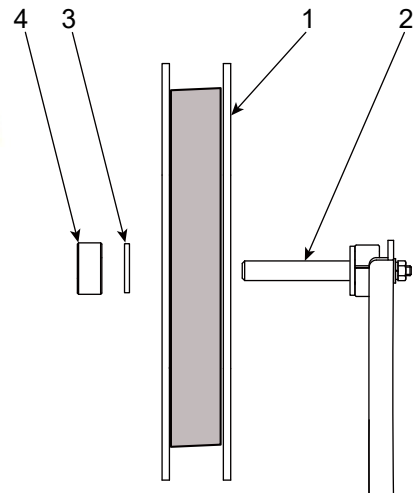

2 to 9 mm sequin (standard spec.)

Push down the sequin plate spring 1 to your side, and insert sequins 2 into the sequin guide 3. Move the sequin lever 4 to directions indicated by arrows to feed sequins 2 to rear of the movable knife 5.

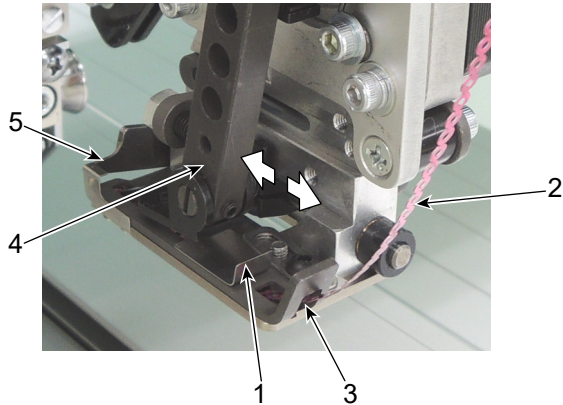

When pushing down the sequin plate spring 1, it sometimes may deform. Therefore, do not bend it strongly.

10 to 22 mm sequin (wide range spec.)

(1) Insert sequins 1 into the sequin guide 2. Loosen screws 3 according to the size of sequins 1 to adjust the position of the guide block 4.

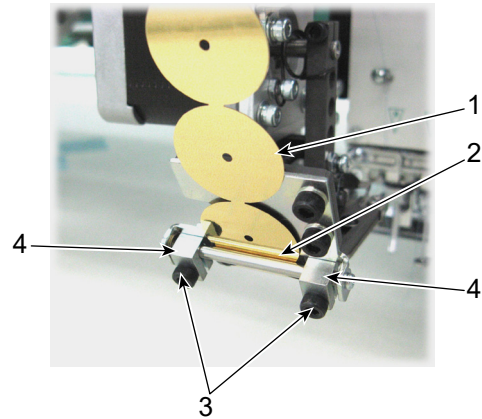

(2) Pass the sequin 1 under the sequin plate spring 2. Move the sequin lever 3 to directions indicated by arrows to feed out one piece of sequin 1 from the movable knife 4.

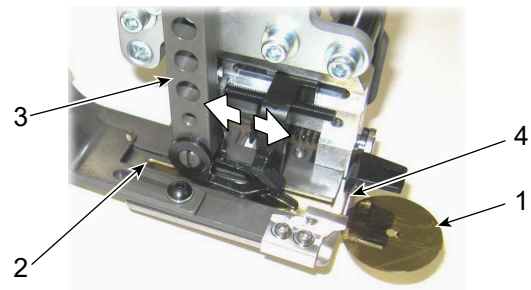

2. Sequin guide (standard spec.)

2-1. Type of sequin guide

There are Sequin guides for L (left) side and for R(right) side. There are following types respectively. Therefore, replace the sequin guide according to the size and type of sequin. (→p.14)

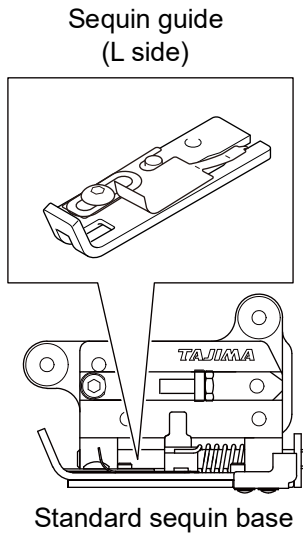

(1) For 2 to 9 mm dead center sequin

There are following six types of sequin guides.

- For 2 mm sequin
- For 3 mm sequin
- For 4 mm sequin
- For 5 mm sequin
- For 7 mm sequin
- For 9 mm sequin

(2) For 9 mm or less special-shaped sequin

There are following seven types of sequin guides.

- For 7 mm ring
- For 9 mm ring
- For 3 x 6 mm strip
- For 3 x 9 mm strip
- For 5x9 mm tear drop
- For 7 x 9 mm ellipse
- For 9 mm front hole eccentric

2-2. Replacement of sequin guide

When stitching various sizes of sequins, replace the sequin guide by the following procedure.

- (1) Remove the standard lower unit from the main body of sequin device. (→p.16)

Standard lower unit



- (2) Remove the screw 1, and replace to the sequin guide 2 corresponding to the sequin size.

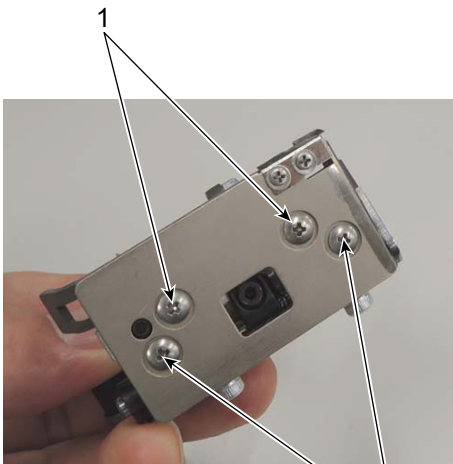

Do not loosen this screw.

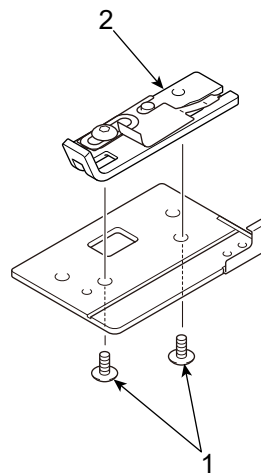

3. Movable knife guide (wide range spec.)

3-1. Type of movable knife guide

There are two types of movable knife guide for L (Left) side and R (right) side. The movable knife guide is attached to the movable knife, and there are different types. Therefore, replace the movable knife according to the size and type of sequin.

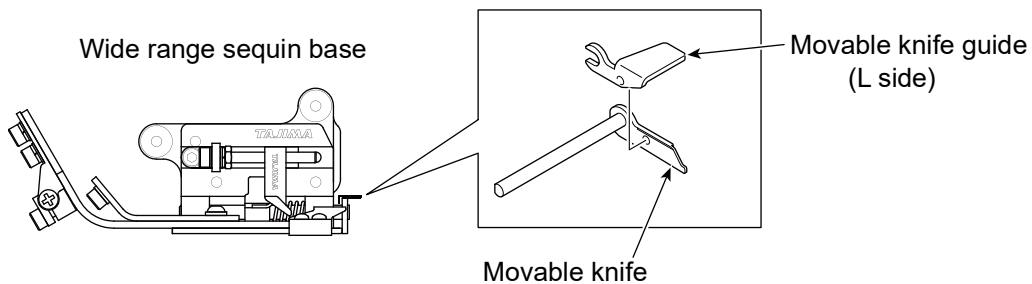

There are the following four types of movable knife guides.
Please ask the distributor for details.

- For 10 to 15 mm dead center sequin
- For 16 to 20 mm dead center sequin and 11 to 22 mm front hole eccentric sequin
- For 21 to 22 mm dead center sequin and 14 to 16 mm front hole eccentric sequin
- For 18 to 22 mm front hole eccentric sequin

3-2. Replacement of movable knife guide

When stitching various sizes of sequins, replace the movable knife by the following procedure.

- (1) Remove the wide range lower unit from the main body of sequin device. (→p.16)
- (2) Remove the screw 1, and replace to the movable knife 2 corresponding to the sequin size.

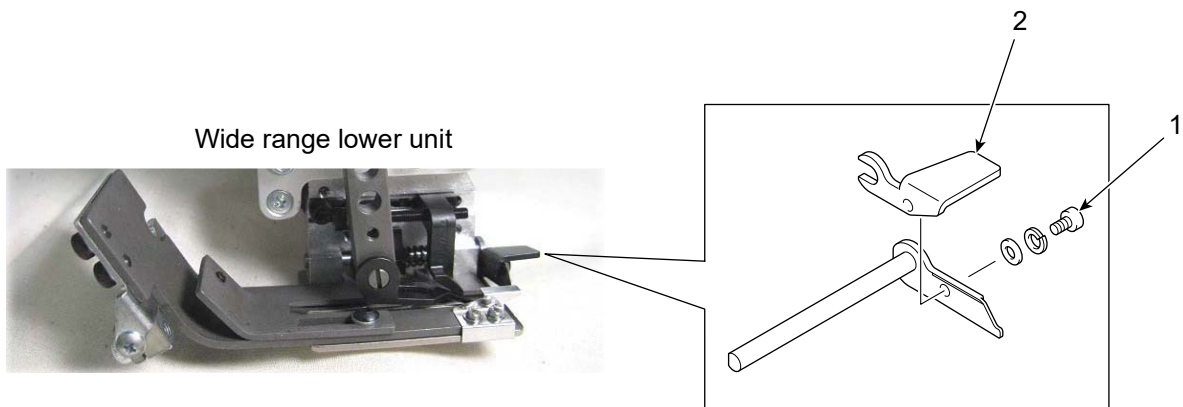

4. Mounting position of motor bracket

The mounting position of the motor bracket 1 differs depending on the sequin size.

Loosen the stepped screw 2 to change the mounting position of the motor bracket 1.

Photo A and B show the example for 15-needle machine.

Photo A

Example of the left side device

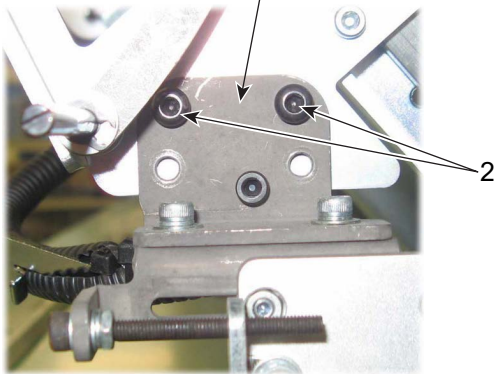

Applicable sequins

- 2 to 9 mm dead center sequin
- 9 mm or less special-shaped sequin
- For 10 to 22 mm dead center sequin

Photo B (Lower unit 4mm up)

Example of the left side device

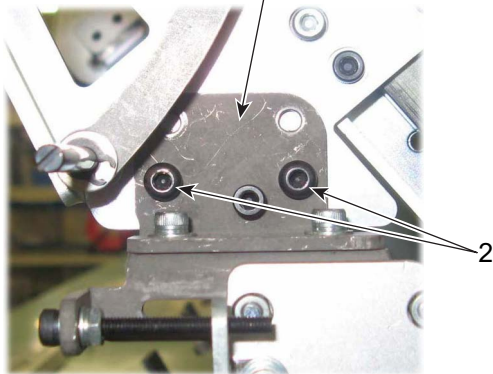

Applicable sequins

- 11 to 22 mm front hole eccentric sequin

Also, the mounting position of the motor bracket 1 is different between 15-needle machine and 12-needle machine.

15-needle machine

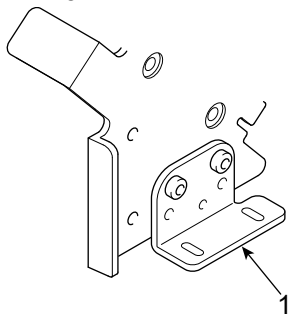

Example of the left side device

12 or less needle machine

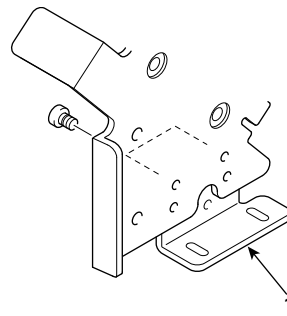





Example of the left side device

5. Adjustment of each part

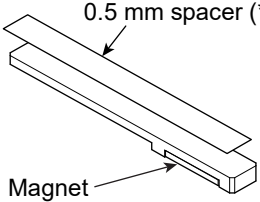
5-1. Height of device

For the height adjustment of the device, use the accessory height gauge. Use the height gauge as shown in the photo below.

Height gauge	How to use
 <p>0.5 mm spacer (*1)</p> <p>Magnet</p> <p>(*1) For beads cord unit, add 0.5 mm spacer.</p>	 <p>TMCR TMCP TMCS TCMX TLMX TFMX TMAR</p>  <p>TFMX-C TWMX-C</p>  <p>TMAR TMBP2 TMBR2 TMBU2 TFMX-IIC</p>

- (1) Lower the device on the operation panel.
- (2) As shown in the figure below, check the height from the bottom face of the device to the needle plate by using the accessory height gauge. When adjustment is necessary, loosen the screws 2, then perform adjustment.

When adjusting the height of the device, lower the motor bracket position. (Photo A of p.16)

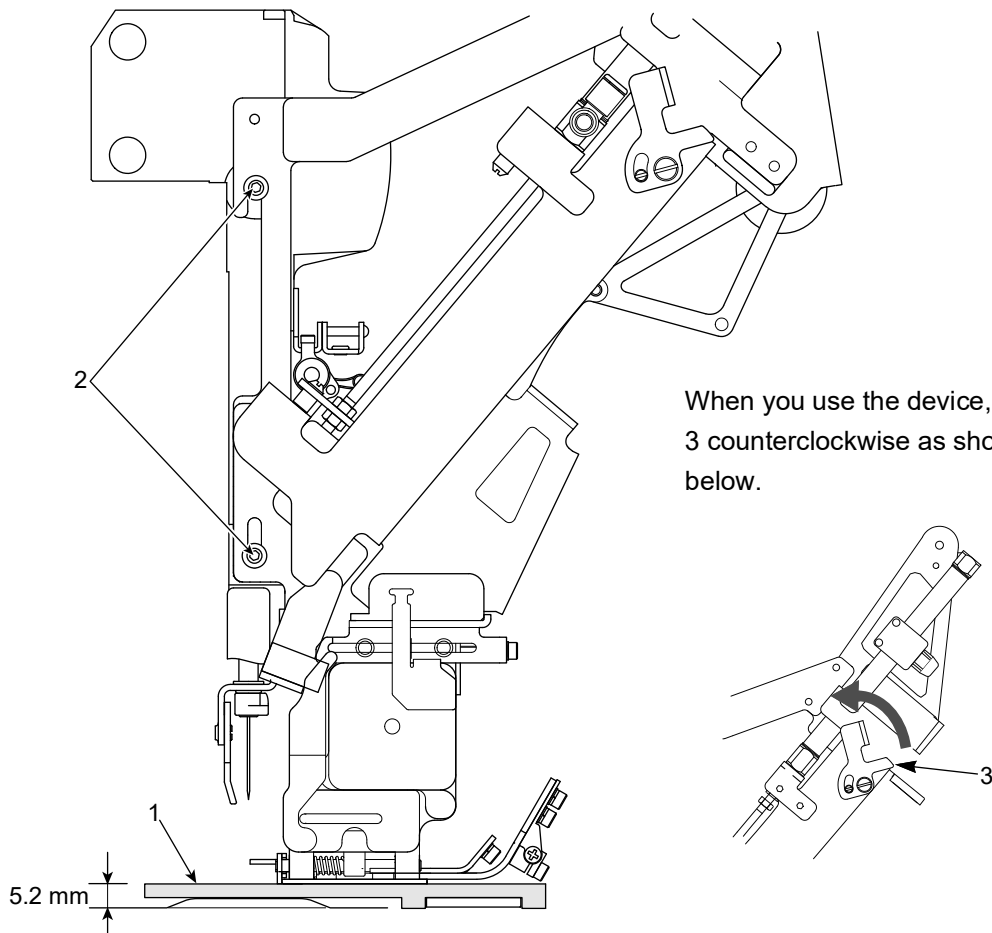

5-2. Cut face

- (1) Insert the accessory sequin-setting tool 1 between 3 mm dia. collar 2 and the sequin lever 3, then loosen the screw 4.

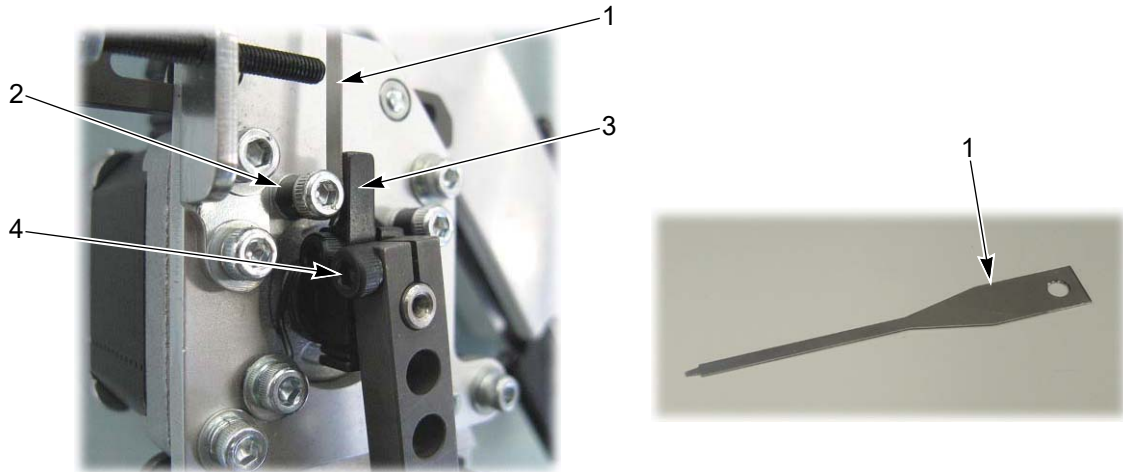

- (2) Feed one piece of sequins 4 by moving the sequin lever 3 in the state that the sequin feed 1 enters into the hole 2. Then, cut sequins 4 by using the movable knife 5.

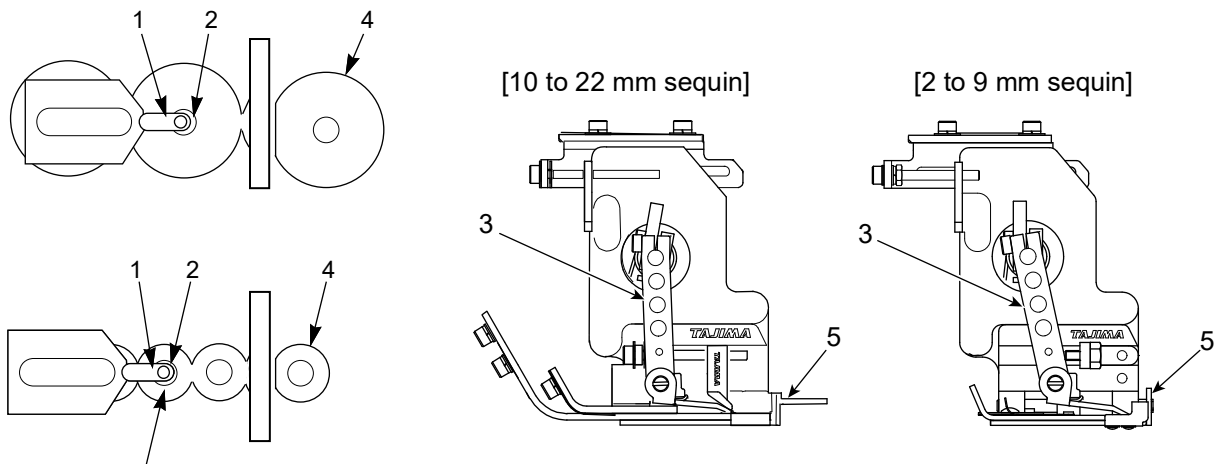

2 or 3 mm dead center sequin is to be entered into the second hole from the movable knife.

- (3) Adjustment differs depending on the shape of the cut face. (Figure A or figure B)

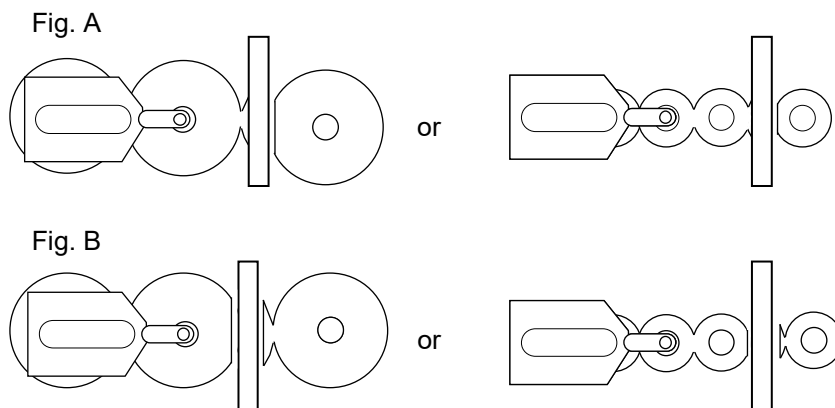

(a) 10 to 22 mm sequin

[When the cut shape is as shown in the figure A]

Loosen the screw 1, and turn the screw 2 to the left. The stopper 3 will move forth. After adjustment, tighten the screw 4.

[When the cut shape is as shown in the figure B]

Loosen the screw 1, and turn the screw 2 to the right. The stopper 3 will move back. After adjustment, tighten the screw 4.

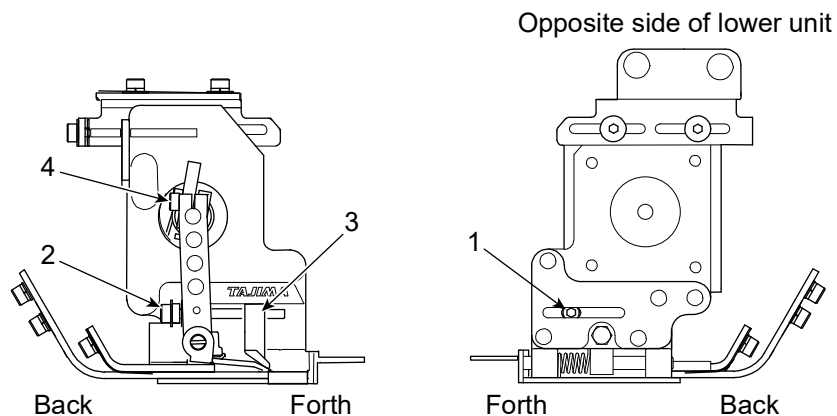
**(b)** 2 to 9 mm sequin

[When the cut shape is as shown in the figure A]

Loosen the screw 1, and turn the screw 2 to the left. The stopper 3 will move forth. After adjustment, tighten the screw 4.

[When the cut shape is as shown in the figure B]

Loosen the nut 1, and turn the screw 2 to the right. The sequin feed 3 will move back. After adjustment, tighten the screw 4.

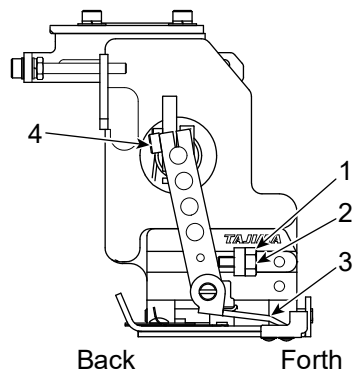

5-3. Front-to-back adjustment of sequin plate spring

- (1) Loosen the button screw 1.

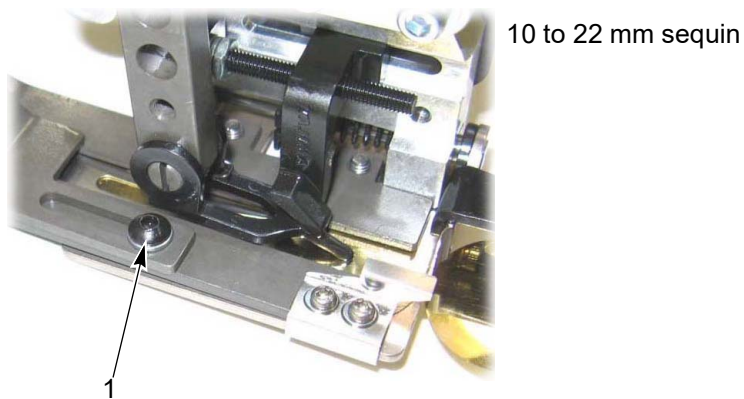
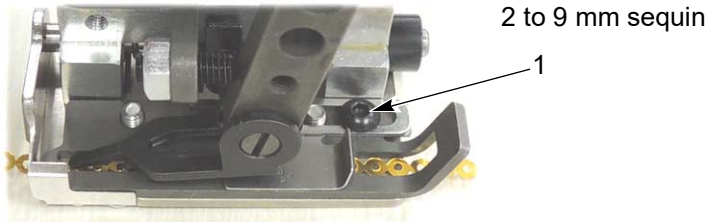

- (2) For 2 to 9 mm sequin, adjust front/rear position so that the tip 4 of the sequin plate spring 3 can enter into the center of the sequin hole in the state that the sequin feed 2 is entered into the sequin hole (refer to photos above). Then, tighten the button screw 1.

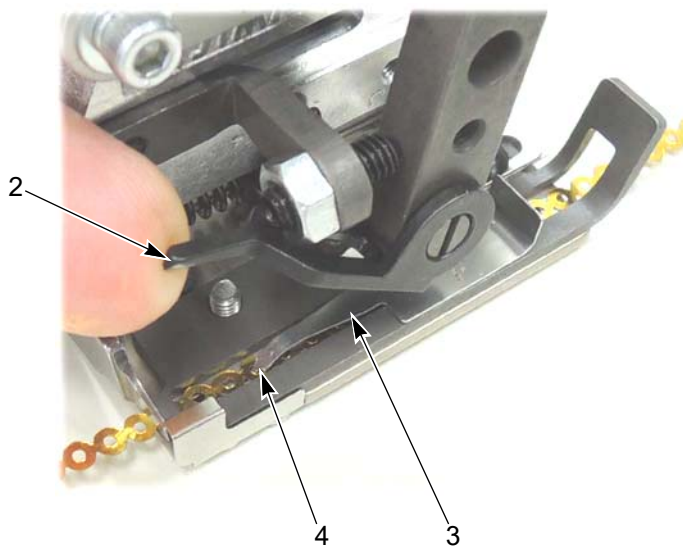

2 to 3 mm sequin

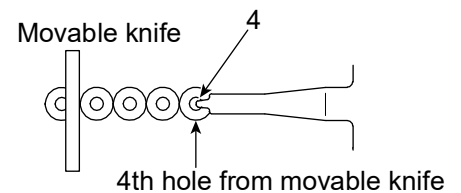

4 to 9 mm sequins

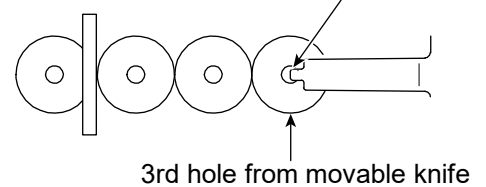

- (3) For 10 to 22 mm sequin, adjust the position so that the tip 6 of the sequin plate spring 5 locates at the center between 1st and 2nd hole of sequin from the movable knife. Then tighten the button screw 1.

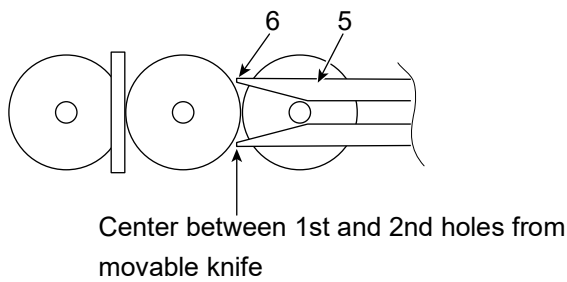

5-4. Adjustment of needle location

- (1) To adjust the back and forth direction, loosen the screw 1 and turn the screw 2.

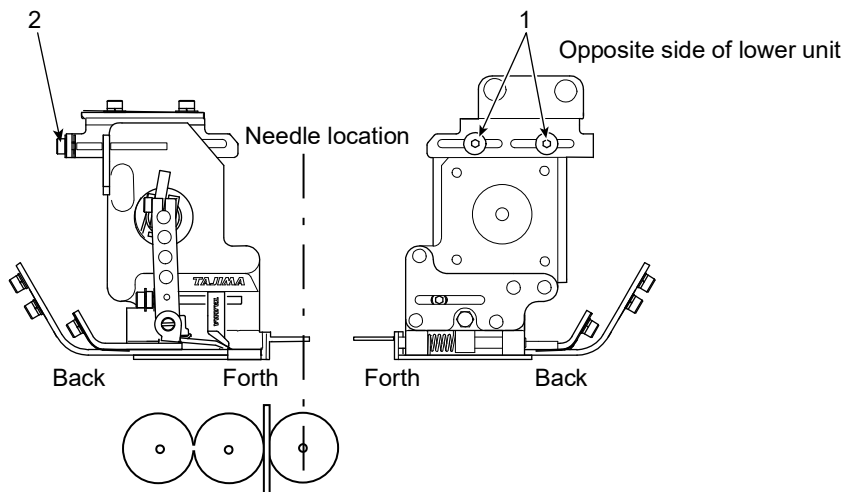

- (2) Loosen the screw 1 for adjusting the left and right, turn the screw 2 to move the motor base 3 left and right.

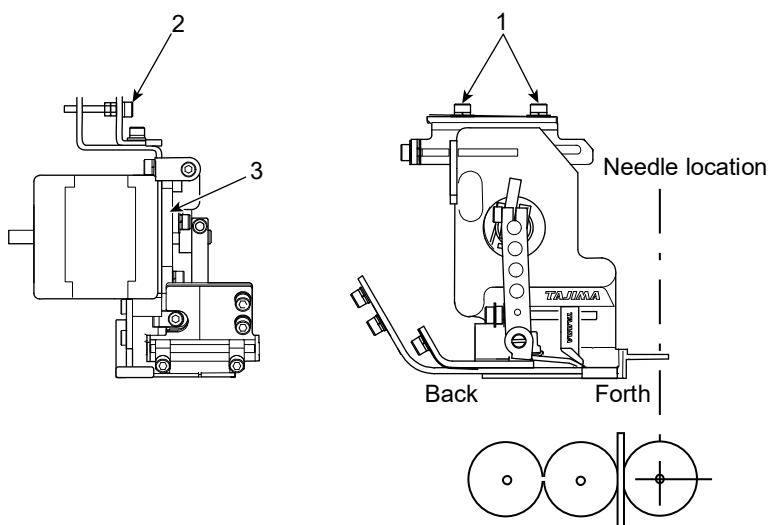

6. Up/down speed

6-1. Air check

Check the air pressure in the state that the air compressor 1 and air regulator 2 of the embroidery machine are connected.

When adjust is necessary, follow the procedure below.

(1) Connect the air compressor 1 and the regulator 2.

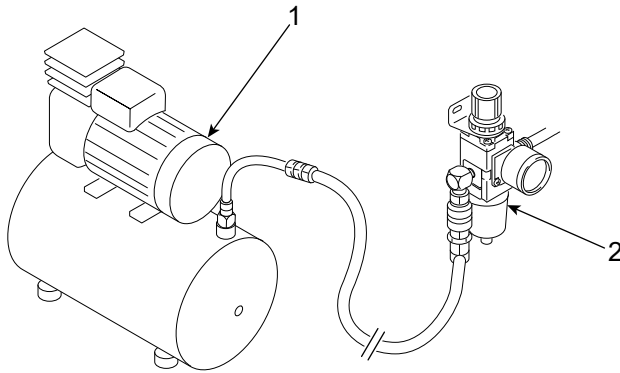

(2) Pull up the cap 1, turn it and set the air pressure value to 0.55 (Mpa).

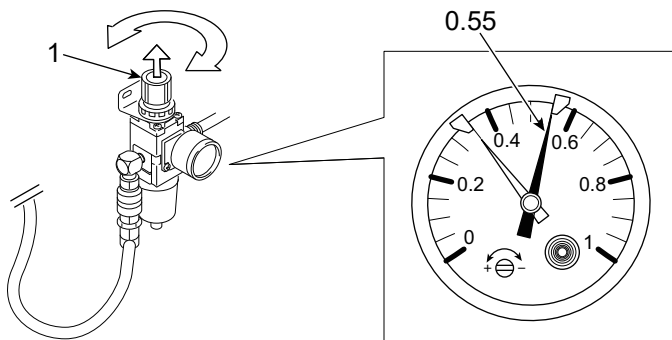

6-2. Adjustment of speed controller

Move the sequin device up and down, and adjust the up/down speed by the speed controller (upper) 1 and speed controller (lower) 2.

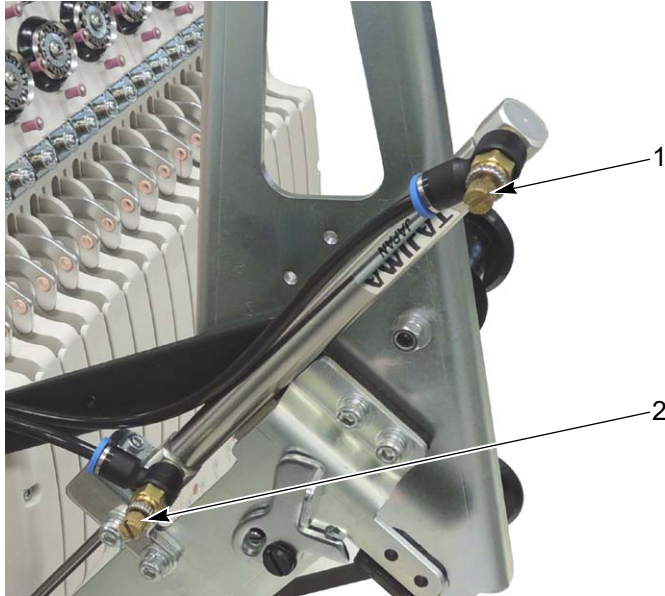

[How to adjust]

Loosen the lock nut, and turn the speed controller to adjust.

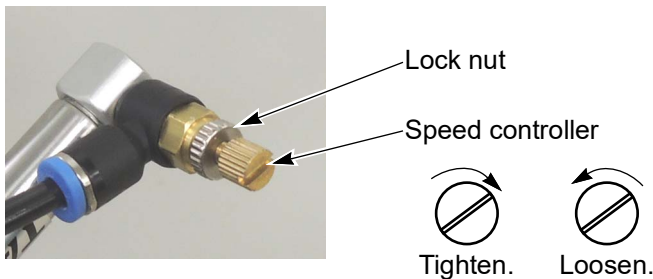

Adjust the controller considering a mutual balance so that only one speed controller is not turned too much or is not loose too much.

(1) Up speed

[To decrease the speed]

Tighten the speed controller (lower) 2.

[To increase the speed]

Loosen the speed controller (lower) 2.

(2) Down speed

[To decrease the speed]

Tighten the speed controller (upper) 1.

[To increase the speed]

Loosen the speed controller (upper) 1.

7. To raise the devices individually

This function is not applicable for single head machine.

When raising or lowering sequin devices of all heads all together, refer to “To raise/lower Sequin devices at all heads together in a batch”.

It is possible to operate the finger valve only when you raise the lowered device by hand. (The raised device cannot be lowered by this operation.)

(1) Turn OFF the finger valve 1.

OFF: Without air pressure

ON: With air pressure

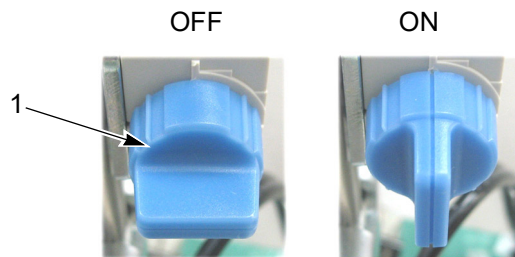

Finger valve is not equipped in single head machine.

(2) Hold the handle 2 to raise the device.



(3) Fix the device by the clutch lever 3.

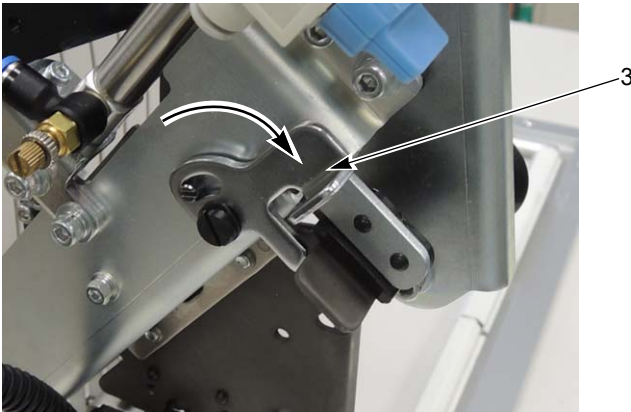

! CAUTION

! In this state, turn ON the finger valve, and release the clutch lever 3 so that the device is suddenly lowered.

(4) After lowering the device, turn ON the finger valve.

Chapter 3 TMCR, TMAR, TMBR2, TMBU2

1. Standard spec.

1-1. 2 to 9 mm sequin

The mark with • in the table below indicates the needle location position.

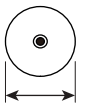
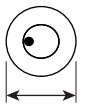
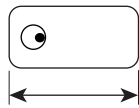
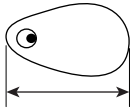
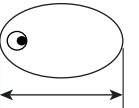
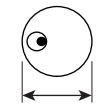
2 to 9 mm sequin					
2 to 9 mm dead center sequin	9 mm or less special-shaped sequin				
	Ring	Strip	Tear drop	Ellipse	Front hole eccentric
 2 to 9 mm	 9 mm or less	 9 mm or less	 9 mm or less	 9 mm or less	 9 mm or less

The sequin presser foot corresponding to sequin to be used are in the table below.

Sequin type	Sequin size	Sequin presser foot to be used
Dead center sequin	2 to 4 mm	Presser foot :Sequin :2-4 mm dia.
	5 to 7 mm	Presser foot :Sequin :7mm dia. or less
	8 to 9 mm	Presser foot :Sequin :9mm dia. or less
	For cap frame	PRESSER FOOT :SEQUIN :CAP/ 10MM OR MORE DIA.
Special-shaped sequin	9 mm ring, 9 mm front hole eccentric	Presser foot :Sequin :9mm dia. or less
	7 mm ring, 3 x 6 mm strip, 3 x 9 mm strip, 5 x 9 mm tear drop, 7 x 9 mm ellipse	Presser foot :Sequin :7mm dia. or less

1. Needle clamp :Sequin



2. Needle

2 mm dead center sequin	DB-K5SS #65/9
3 to 9 mm Dead center sequin	Normal needle (Needle type is not specified.)
9 mm or less Special-shaped sequin	

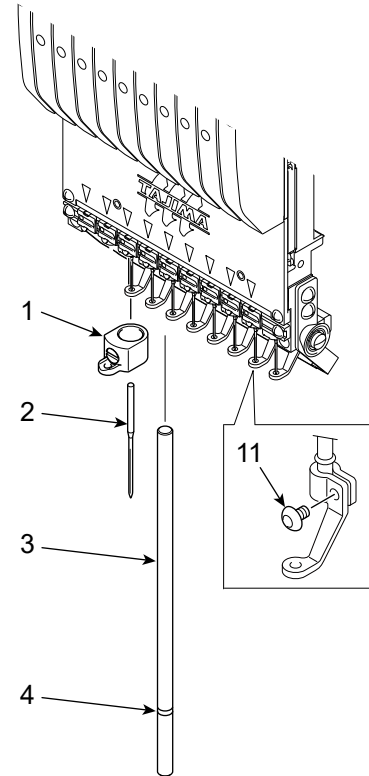

3. Shaft :Sequin presser foot

4. O-ring :SO-3-90

5. Presser foot :Sequin :Cap/10 mm or more dia.

6. PRESSER FOOT :SEQUIN :9MM OR LESS DIA.

7. PRESSER FOOT :SEQUIN :7MM OR LESS DIA.

8. PRESSER FOOT :SEQUIN :2-4MM DIA.

9. Base :Sequin presser foot :B

10. Movable knife presser

11. Hexagon socket head button screw :M3*5

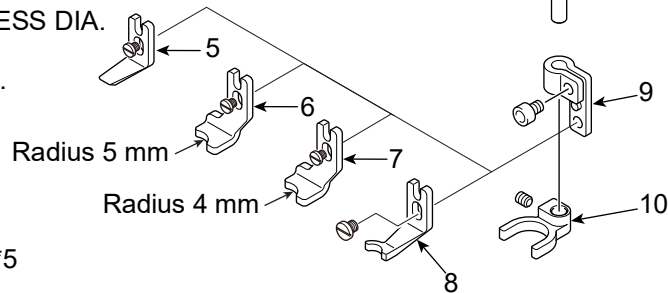

2nd needle when the device is installed at the right side
(Refer to [Note] below.

[Note]

When installing the sequin device on the right side, replace the 2nd presser foot set screw from the hexagon socket head cap screw to the hexagon socket head button screw (M3*5). If it is not replaced, the movable knife presser may hit the hexagon socket head cap screw when the 2nd needle is lowered as shown in figure A.

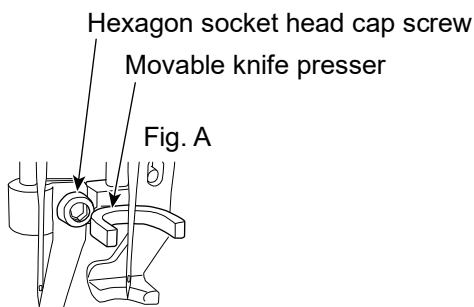

2. Wide range spec.

2-1. For 10 to 22 mm dead center sequin

1. Needle clamp :Sequin :Wide range



2. Normal needle
Needle type is not specified.
3. Shaft :Sequin presser foot
4. O-ring :SO-3-90
5. Presser foot :Sequin :Cap/10 mm or more dia.
6. Base :Sequin presser foot :B
7. Hexagon socket head button screw :M3*5
2nd needle when the device is installed at the right side
Refer to [Note] (→p.28)

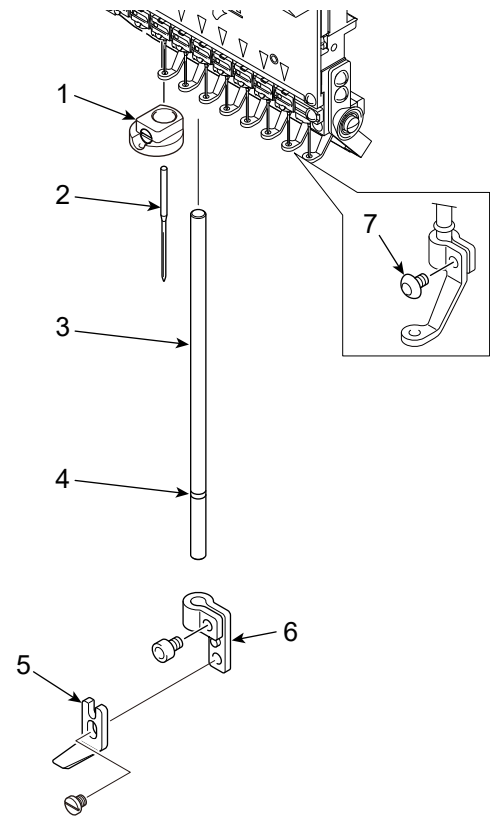

2-2. 11 to 22 mm front hole eccentric sequin

1. Needle clamp :Sequin :Wide range
The direction of the needle clamp turns upside down.



2. Needle (DB-K5Z2 #11NY)
3. Shaft :Sequin presser foot
4. O-ring :SO-3-90
5. Presser foot :Sequin :Cap/10 mm or more dia.
6. Base :Sequin presser foot :B
7. Hexagon socket head button screw :M3*5
2nd needle when the device is installed at the right side
Refer to [Note] (→p.28)

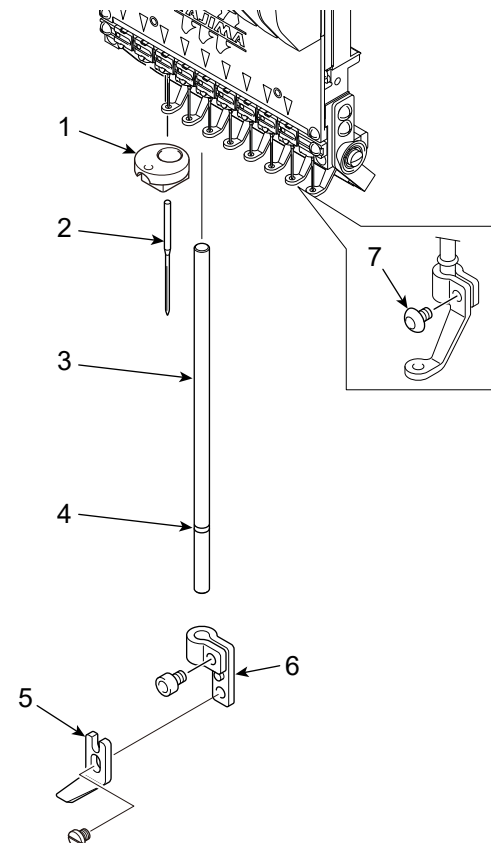

3. Setting and operation (TMCR, TMAR)

3-1. Cancellation of Functional Limit Level

Before setting the sequin device IV, cancel the functional limit level by the following procedure and then perform each setting.

The following explanation is the example for TMAR. For other models, the screen display may be different, but the explanation is the same as one of TMAR.

(1) Icon G

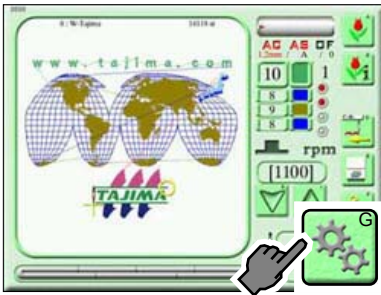

(2) Press P6 twice.

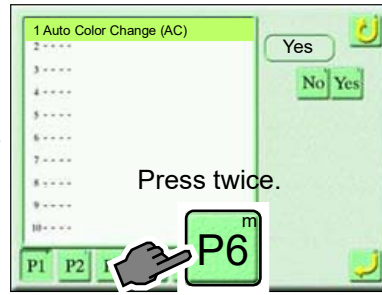

(3) Icon S

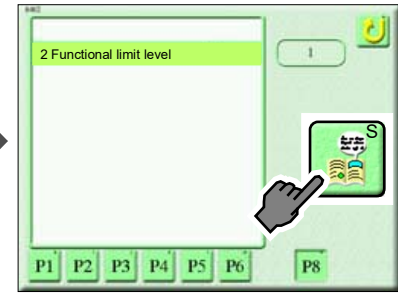

(4) Input a password.



(5) To set



(6) SEL

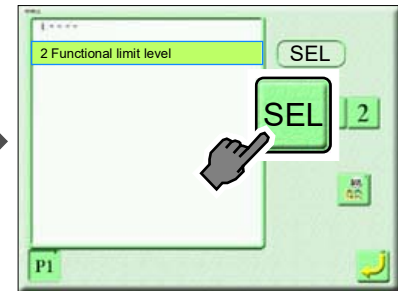

(7) To set

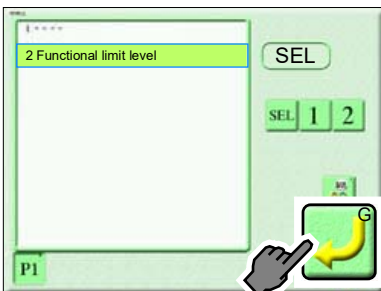

(8) Icon A

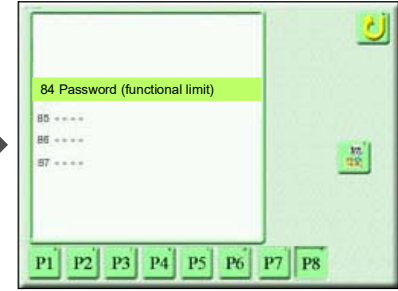
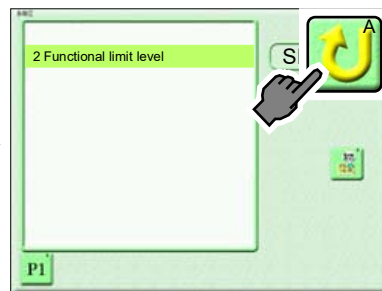

3-2. Basic settings

To actuate the device, it is necessary to set the following parameters on the machine side.

When the device is mounted to the right side of the head: Select "1 Sequin device (R)".

When the device is mounted to the left side of the head: Select "2 Sequin device (L)".

The following explanation is the example for TMAR. For other models, the screen display may be different, but the explanation is the same as one of TMAR.

The following explanation is the example when the functional limit level is "1".

(1) Cancel the functional limit level. (→p.30)

(2) P7

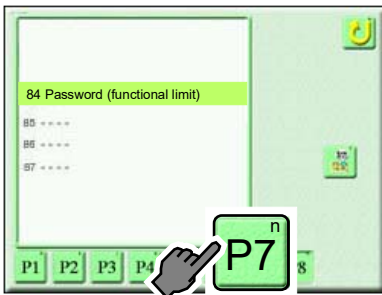

(3) 77 Optional Device (Hardware)

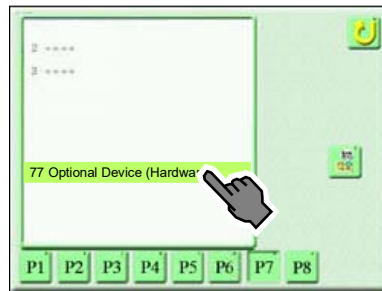

(4) Icon T

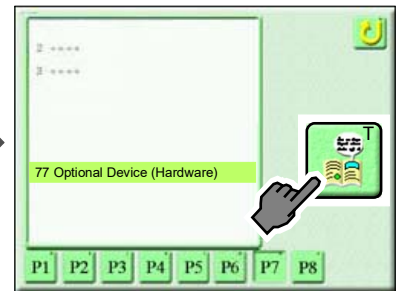

(5) Sequin device (R) or (L)

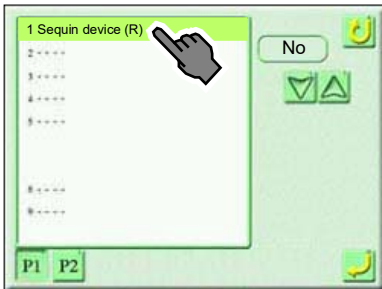

- 1 Sequin device (R):
To equip to the right side
- 2 Sequin device (L):
To equip to the left side

(6) SQ4

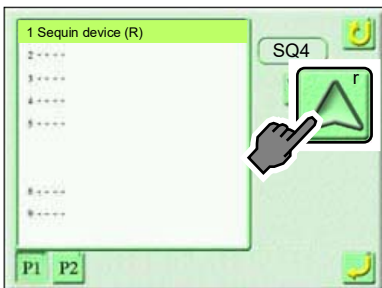

- SQ4: Sequin device IV
- SQ3: Sequin device III
- ESQ-C: ESQ-C
- No: Not to use

(7) To set

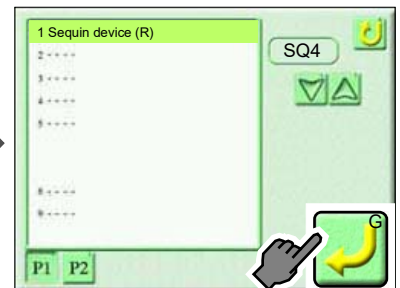

3-3. Setting of Air compressor

Set this function when sequin device IV is equipped.

The following explanation is the example for TMAR. For other models, the screen display may be different, but the explanation is the same as one of TMAR.

The following explanation is the example when the functional limit level is "1".

(1) Cancel the functional limit level. (→p.30)

(2) P7

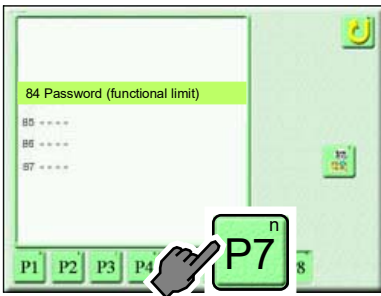

(3) 77 Optional Device (Hardware)

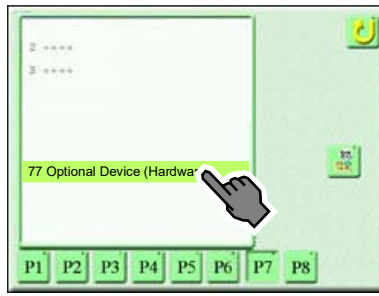

(4) Icon T

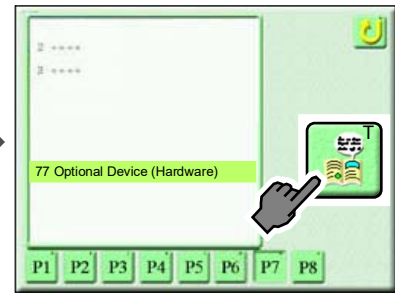

(5) 8 Air Pressure Sensor

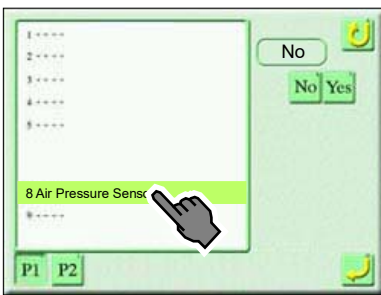

(6) Yes

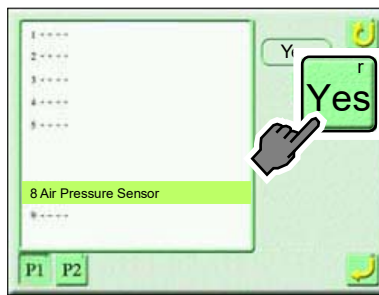

(7) To set

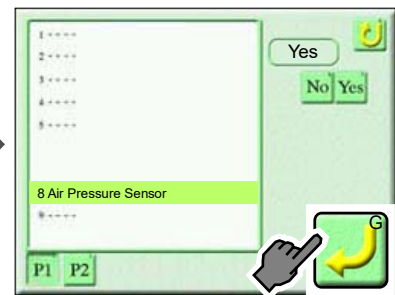

3-4. Setting of sequin chip feed amount

The following explanation is the example for TMAR. For other models, the screen display may be different, but it is the same as one of TMAR.

The following explanation is the example of setting the sequin tip feed amount of the right sequin device.

Rough standard of sequin feed amount is +1.0 mm for sequin size.

(1) Icon G

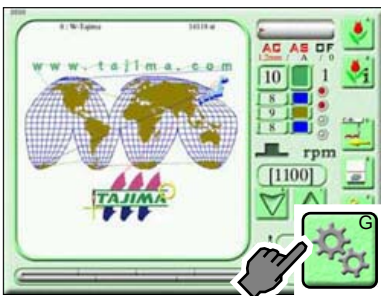

(2) P5

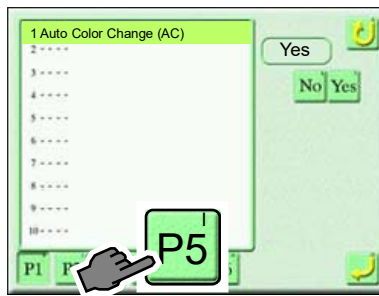

(3) 43 Sequin feed amount (R)

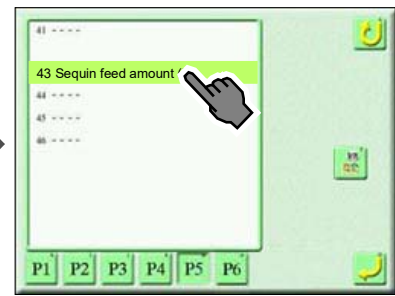

(4) Icon T

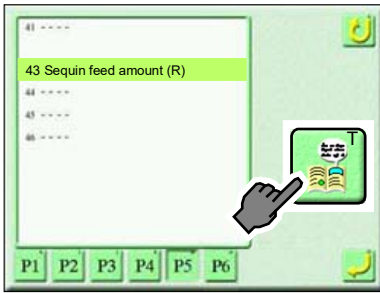

(5) Input the value of ALL, 1H

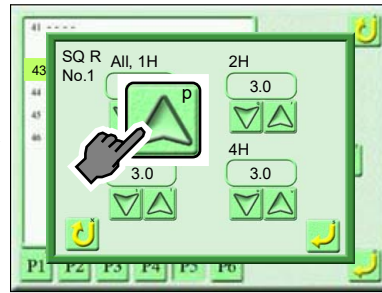

TMCR can select feed amount for each head group. For the details, refer to the user's manual of the machine.

(6) To set

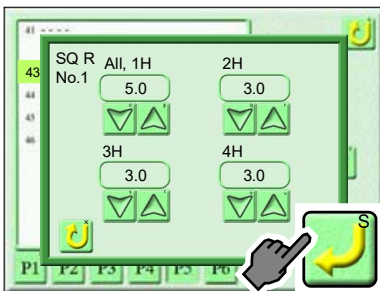

3-5. Insertion of Jump at Sequin

Select whether one stitch of non-data jump code is inserted after sequin output or not.

Select whether one stitch of non-data jump code is inserted just after sequin feed (output) or not. When you want to tighten thread forcibly after sequin feed, select "Yes". Usually select "No".

The following explanation is the example for TMAR. For other models, the screen display may be different, but it is the same as one of TMAR.

The following explanation is the example when the functional limit level is "1" and "After output" is set to "Yes".

(1) Cancel the functional limit level. (→p.30)

(2) P7

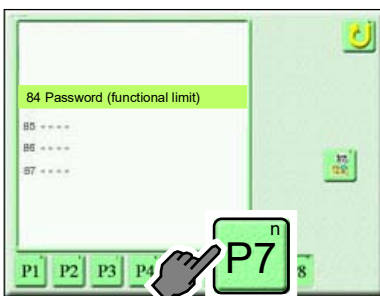

(3) 77 Optional Device (Hardware)

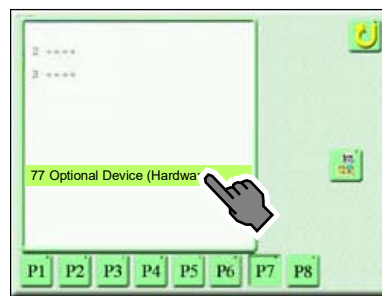

(4) Icon T

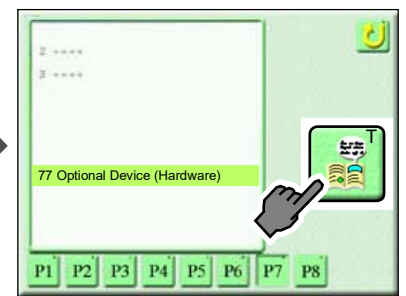

(5) 3 Insertion of jump at sequin

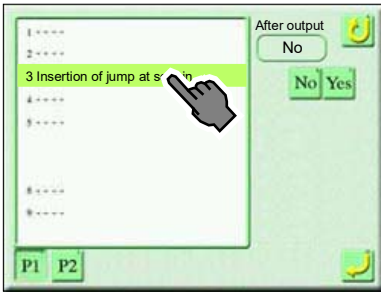

(6) Set "After output" to "Yes"

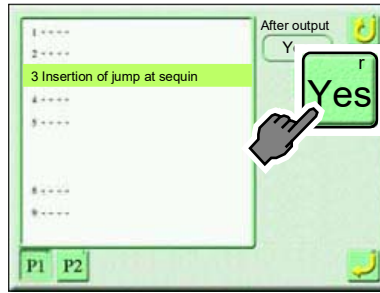

(7) To set

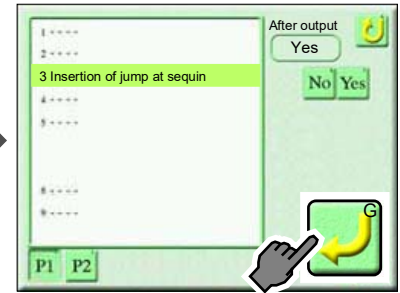

3-6. Auto lifting - Sequin device

Select whether sequin device moves up automatically at ATH working by frame stepping.

The following explanation is the example for TMAR. For other models, the screen display may be different, but it is the same as one of TMAR.

The following explanation is the example of raising the device automatically at ATH working by frame stepping and at thread breakage.

(1) Icon G

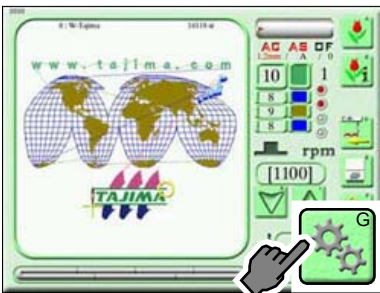

(2) P5

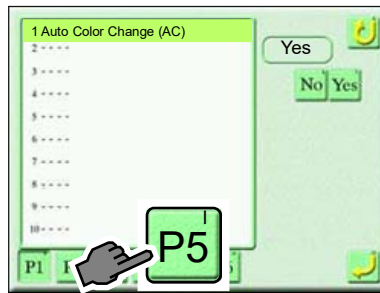

(3) 45 Auto lifting - Sequin device

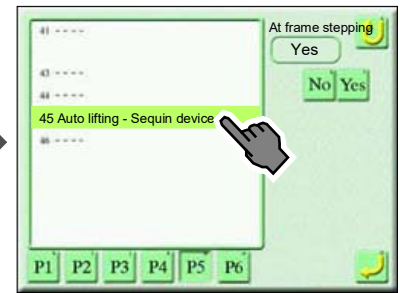

(4) Move up automatically

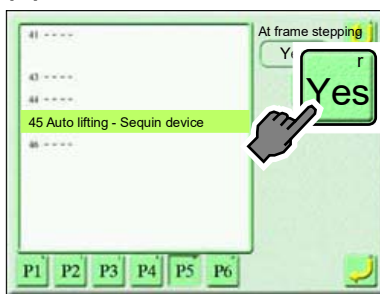

No: Not to move up
Yes: Move up

(5) To set

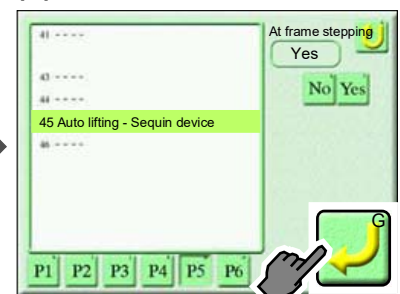

3-7. Sequin chip feed

When performing the setting described below, it is possible to feed sequin chips by operation of the tension base switch.

The setting value of the following parameter is applied for sequin feed amount.

Refer to "3-4. Setting of sequin chip feed amount (→p.32)".

It is not possible to operate the device when color change is not set to the needle side where the device is mounted. R is the 1st needle and L is the last needle.

The following explanation is the example for TMAR. For other models, the screen display may be different, but it is the same as one of TMAR.

The following explanation is for the state that the functional limit level is "1".

- (1) Perform color change to the needle bar side where the device is mounted.
- (2) Cancel the functional limit level. (→p.30)
- (3) 85 Machine adjustment
- (4) Icon T
- (5) P2

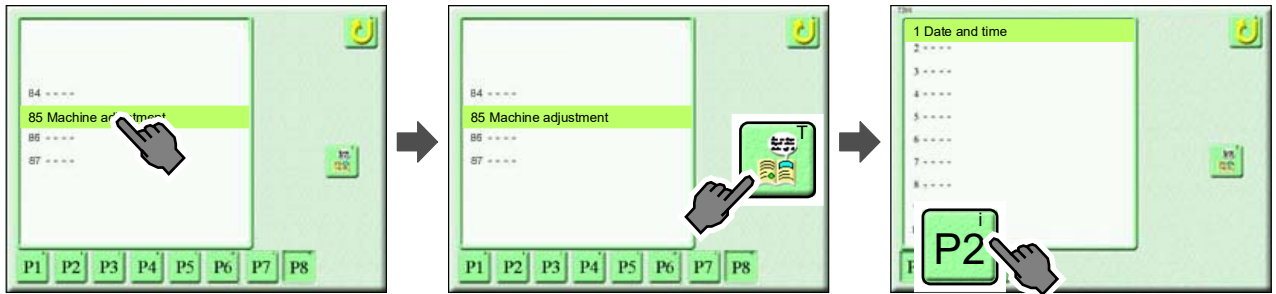

- (6) 17 Sequin chip feed



- (7) Chip Feed

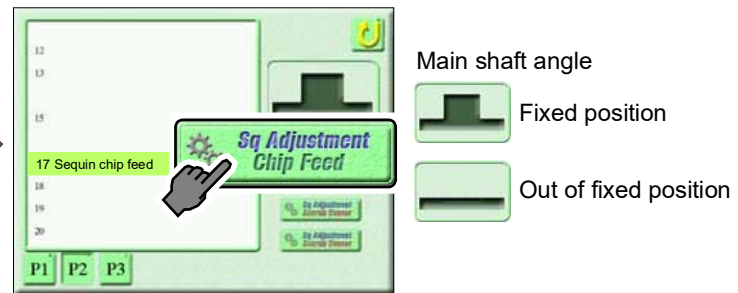

For TMCR, TMAR

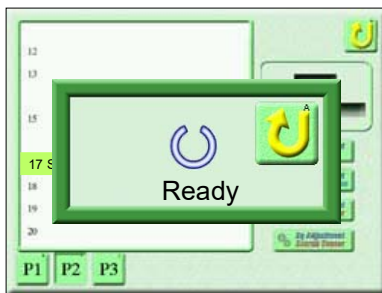

- (8) Press H switch on the tension base. The sequin chip will be fed out.



- (9) Icon A (Completed)

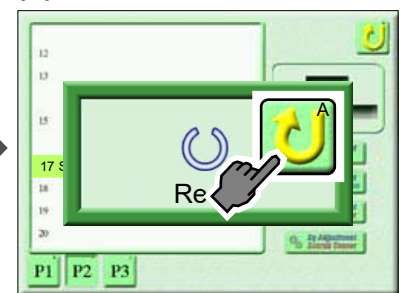

For TMBR2, TMBU2

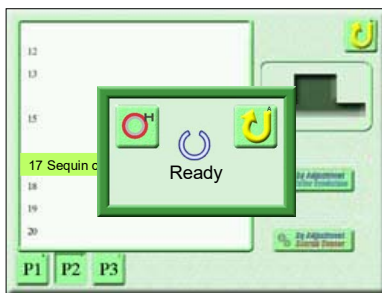

- (8) Icon H

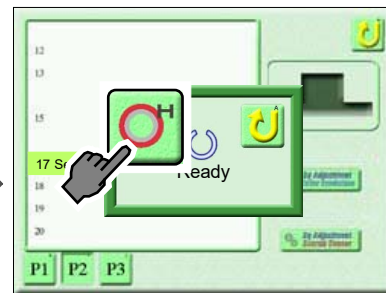

- (9) Icon A (Completed)

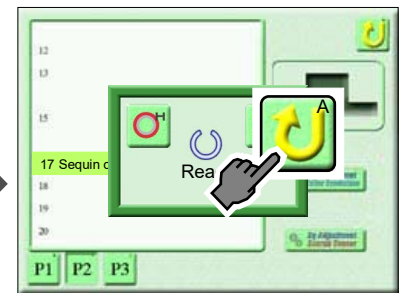

Select Icon H. The sequin chip will be fed out.

3-8. To raise/lower Sequin device at all heads together in a batch

Make sequin devices of all heads move up/down all together by manual operation.

! CAUTION

⊘ When performing this operation, do not put your hands, etc. under the needle or on the machine table. If your hands are under the needle or on the machine table, you could be injured by the moving up/down of sequin device.

(1) Icon F

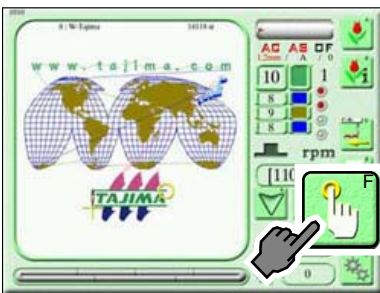

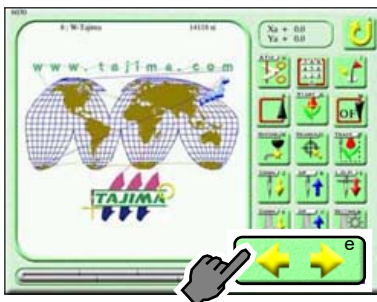

(2) Icon e



(3) Icon W or icon X



 It will move down.

 It will move up.

(4) Yes

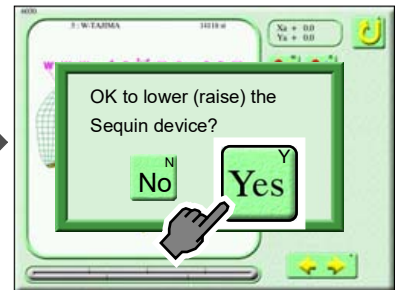

4. Replacement of parts (from standard spec. to wide range spec.)

When changing from 2 to 9 mm sequin (standard spec.) to 10 to 22 mm sequin (wide range spec.), replace the parts by the following procedure.

4-1. Replacement of parts near needle

(1) Loosen the screw 1, and detach the needle clamp 2 for standard specification and the needle 3.

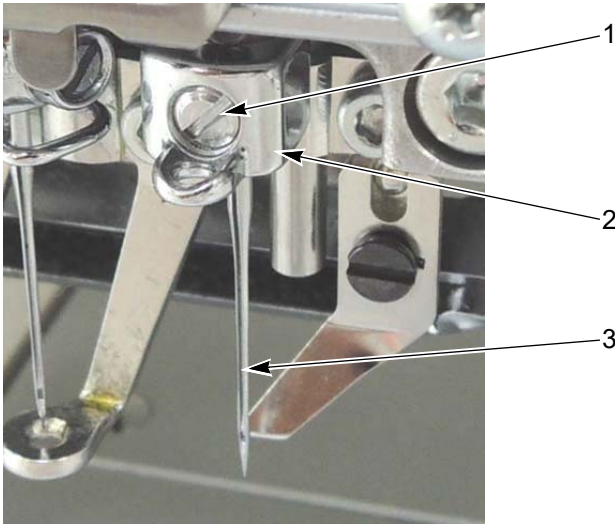

(2) Attach the needle clamp 1 and needle 2 of wide range spec. in the state of facing the front, and tighten the screw 3.

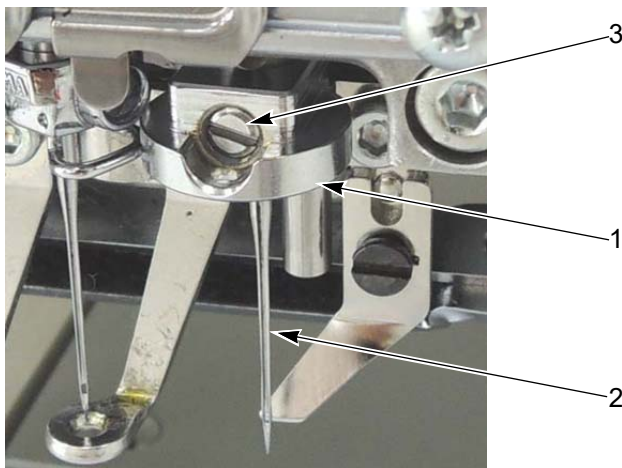

[About the needle clamp 1 for wide range spec.]

The photo is for 10 to 22 mm dead center sequin

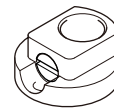

For 11 to 22 mm front hole eccentric sequin, top and bottom are reversed.



(3) Press D switch on the tension base twice. The presser foot will move down to the lower dead point.

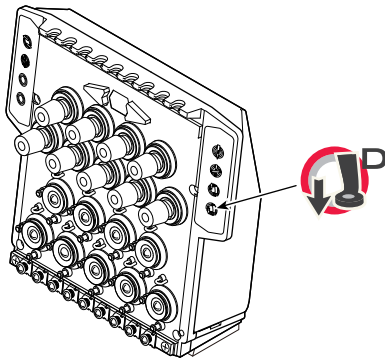

For TMBR2, TMBU2, select icon LDP.

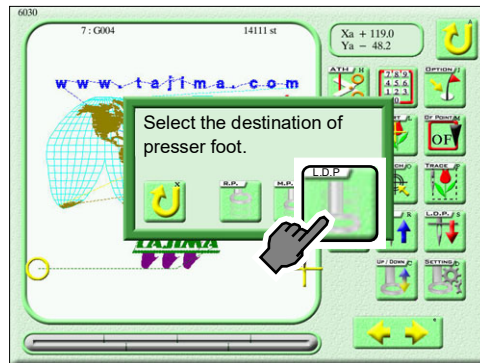

(4) Remove the screw 1 and detach the presser foot 2.

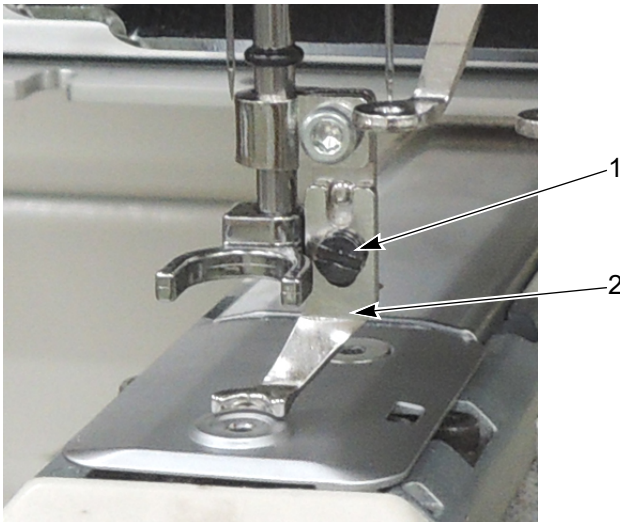

The photo is for the presser foot for 2 to 4 mm.

(5) Loosen the screw 1, and detach the movable knife presser 2.

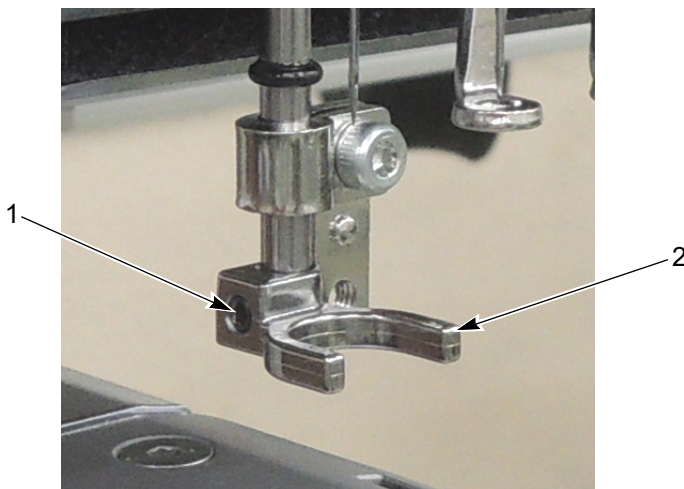

- (6) Attach the presser foot 1 for 10 mm or more sequin, adjust the height according to the fabric thickness, and then tighten the screw 2.

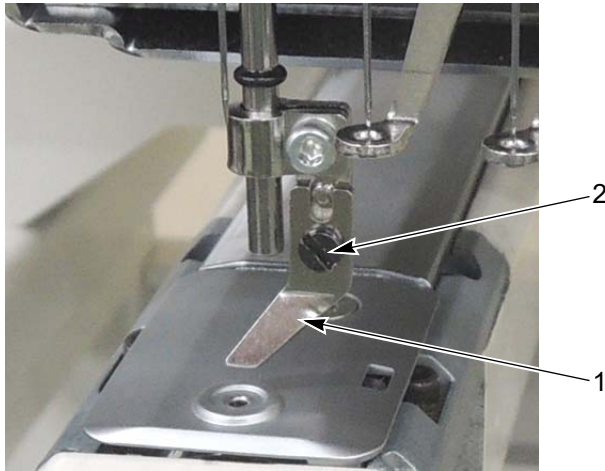

- (7) Press C switch on the tension base one time. The presser foot will move up to the retractable position.

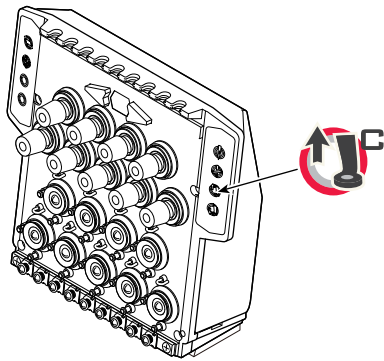

For TMBR2, TMBU2, select icon RP.

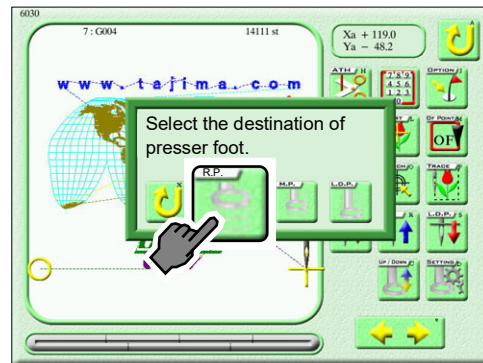

4-2. Replacement of lower unit parts

- (1) Remove the screw 1, and detach the standard sequin base 2.

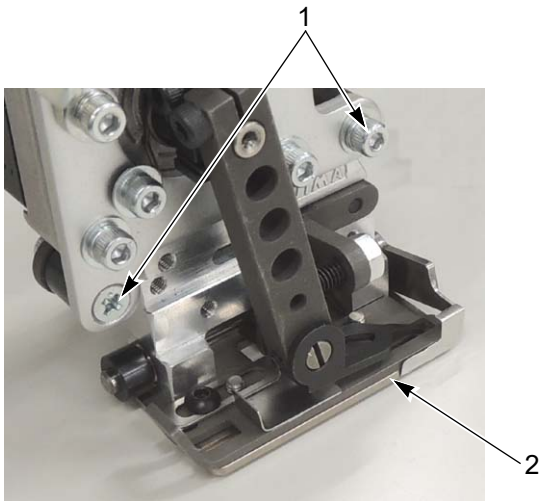

- (2) Attach the wide range sequin base 1, and tighten the screw 2.

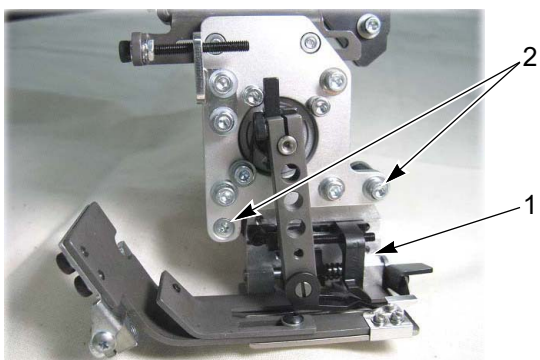

Check if the tip 3 of sequin feed is entered into the groove 4 of the fixed knife.

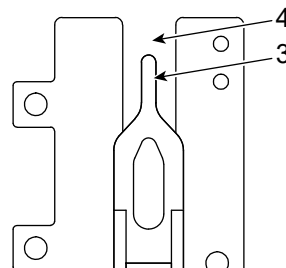

5. Replacement of parts (from wide range spec. to standard spec.)

When changing from 10 to 22 mm sequin (wide range spec.) to 2 to 9 mm sequin (standard spec.), replace the parts by the following procedure.

5-1. Replacement of parts near needle

- (1) Loosen the screw 1, and detach the needle clamp 2 for wide range spec and the needle 3.

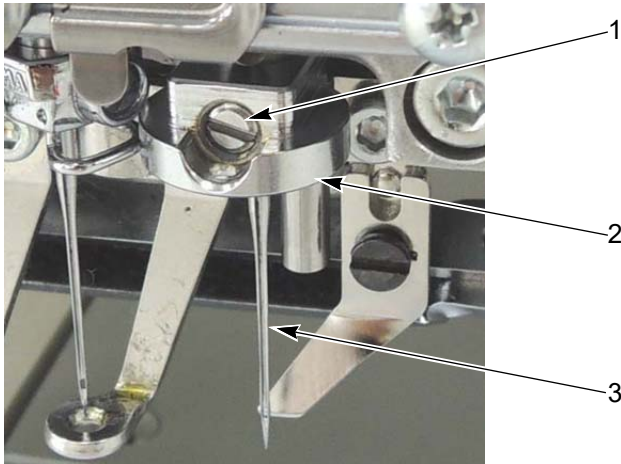

- (2) Attach the needle clamp 1 of standard spec. and needle 2 in the state of facing the front, and tighten the screw 3.

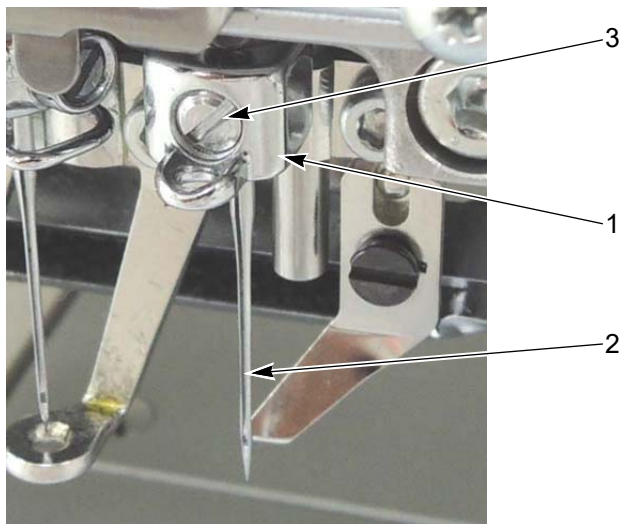

The needle 2 differs depending on needle type.

2 mm sequin: DB-K5SS #65/9

3 to 9 mm dead center sequin, 3 to 9 mm special-shaped sequin: normal needle
(Needle type is not specified.)

(3) Press D switch on the tension base twice. The presser foot will move down to the lower dead point.

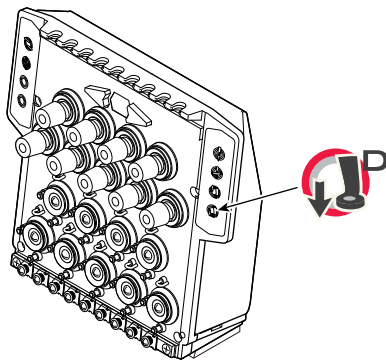

For TMBR2, TMBU2, select icon LDP.

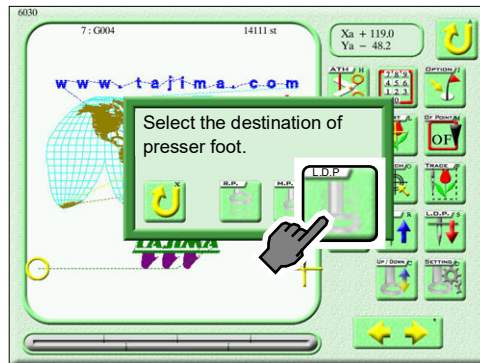

(4) Remove the screw 1, and detach the presser foot 2 for 10 mm or more.



(5) Attach the movable knife presser 1, and tighten the screw 2 temporarily.

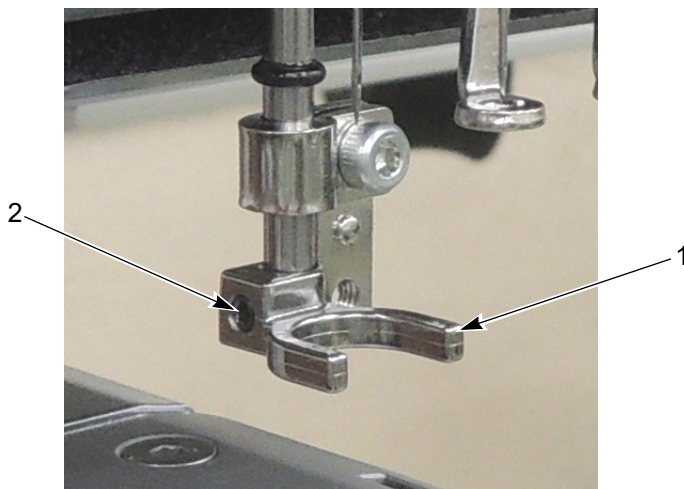

- (6) Attach the presser foot 1, and adjust the height according to the fabric thickness. Then, tighten the screw 2.



The photo is for the presser foot for 2 to 4 mm.

In addition to this, there are the following types. Therefore, select according to the specification.

- For 7 mm or less
- For 9 mm or less
- For cap frame spec.

- (7) Set the main shaft angle to 178°(needle bar lower dead point), and lower the needle bar 1.

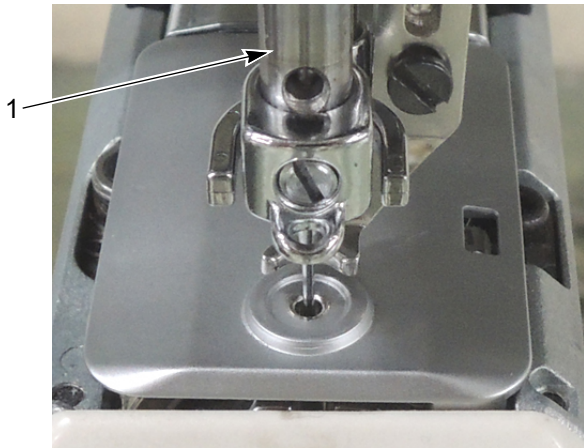

- (8) Adjust the movable knife presser 2 so that the intervals 3 and 4 between the needle clamp 1 and the movable knife presser 2 are the same (Figure A), and also the needle clamp 1 and the lower end face 5 of the movable knife presser 2 are in the same position (figure B), and tighten the screw 6.

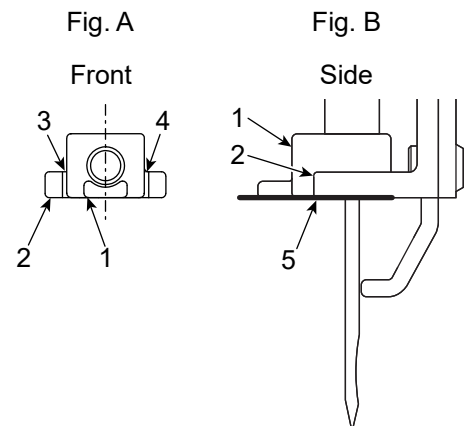

- (9) Return the main shaft angle to 100° (fixed position), and press C switch on the tension base one time. The presser foot will move up to the retractable position.

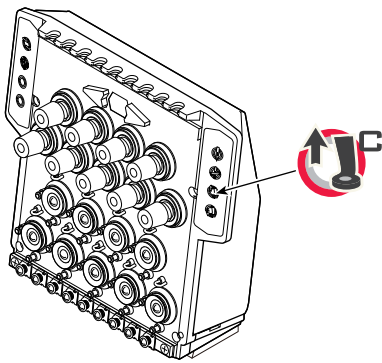

For TMBR2, TMBU2, select icon RP.

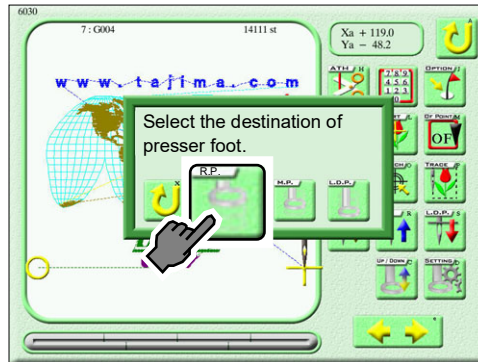

5-2. Replacement of lower unit parts

- (1) Loosen the screw 1, and detach the wide range sequin base 2.

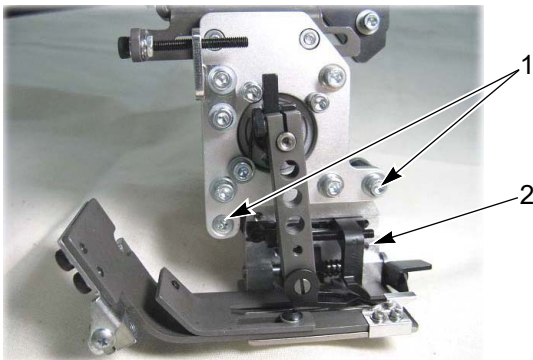

- (2) Attach the standard sequin base 1, and tighten the screw 2.

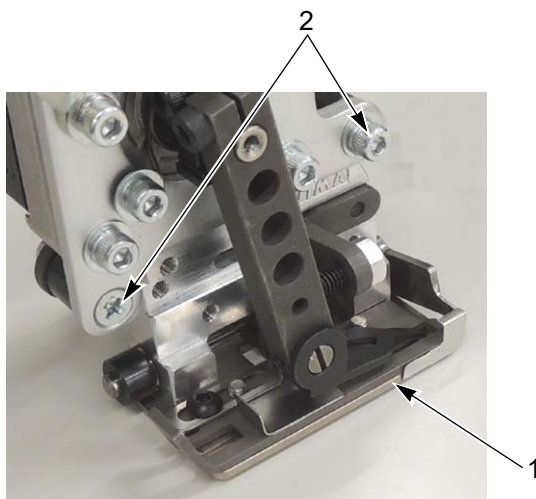

Check if the tip 3 of sequin feed is entered into the groove 4 of the fixed knife.

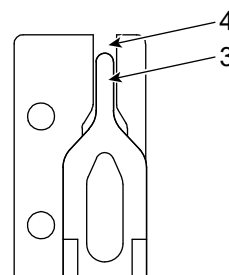

Chapter 4 TMCP, TMCS, TFMX, TWMX-C, TMBP2, TLMX, TCMX

1. Standard spec.

1-1. 2 to 9 mm sequin

The mark with • in the table below indicates the needle location position.

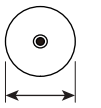
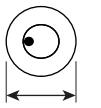
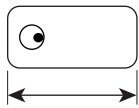
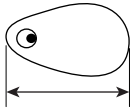
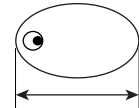
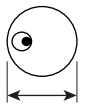
2 to 9 mm sequin					
2 to 9 mm dead center sequin	9 mm or less special-shaped sequin				
	Ring	Strip	Tear drop	Ellipse	Front hole eccentric
 2 to 9 mm	 9 mm or less	 9 mm or less	 9 mm or less	 9 mm or less	 9 mm or less

The sequin presser foot corresponding to sequin to be used are in the table below.

Sequin type	Sequin size	Sequin presser foot to be used
Dead center sequin	2 to 4 mm	Presser foot :Sequin :2-4 mm dia.
	5 to 7 mm	Presser foot :Sequin :7mm dia. or less
	8 to 9 mm	Presser foot :Sequin :9mm dia. or less
	For cap frame	Presser foot :Sequin :Cap
Special-shaped sequin	9 mm ring, 9 mm front hole eccentric	Presser foot :Sequin :9mm dia. or less
	7 mm ring, 3 x 6 mm strip, 3 x 9 mm strip, 5 x 9 mm tear drop, 7 x 9 mm ellipse	Presser foot :Sequin :7mm dia. or less

- 1. Base :Sequin presser foot :47st[S]
(For TMCP, TMCS, TFMX, TWMX-C, TMBP2)

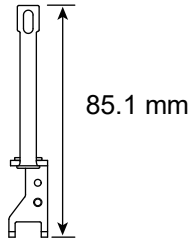

- 1. Base :Sequin presser foot :45st[S]
(For TLMX, TCMX)

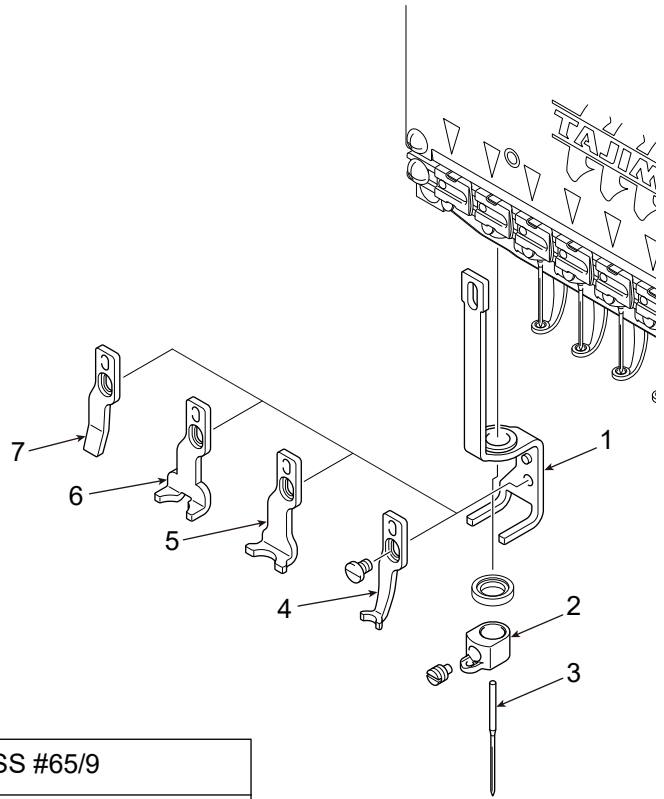
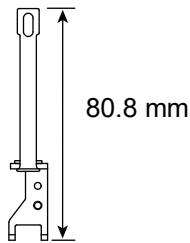

- 2. Needle clamp :Sequin

- 3. Needle

2 mm sequin	DB-K5SS #65/9
3 to 9 mm Dead center sequin	Normal needle (Needle type is not specified.)
9 mm or less Special-shaped sequin	Normal needle (Needle type is not specified.)

- 4. Presser foot :Sequin :2-4 mm dia.
- 5. Presser foot :Sequin :7mm dia. or less
- 6. Presser foot :Sequin :9mm dia. or less
- 7. Presser foot :Sequin :Cap
(For TFMX-C, TWMX-C, TMBP2)

2. Wide range spec.

2-1. 10 to 22 mm sequin

1. Presser foot :Cap
2. Base :Presser foot :[S]
(For TMCP, TMCS, TFMX, TWMX-C, TMBP2)
3. Presser foot :Sequin[S]
(For TLMX, TCMX)
4. Needle clamp :Sequin :Wide range



For 10 to 22 mm dead center sequin



11 to 22 mm front hole eccentric sequin

The direction of the needle clamp turns upside down.

The lower unit goes up by 4mm. (→p.16)

5. For 10 to 22 mm dead center sequin, the needle is normal type. (needle type is not specified.)
For 11 to 22 mm front hole eccentric sequin, the needle is DB-K5Z2 #11NY.

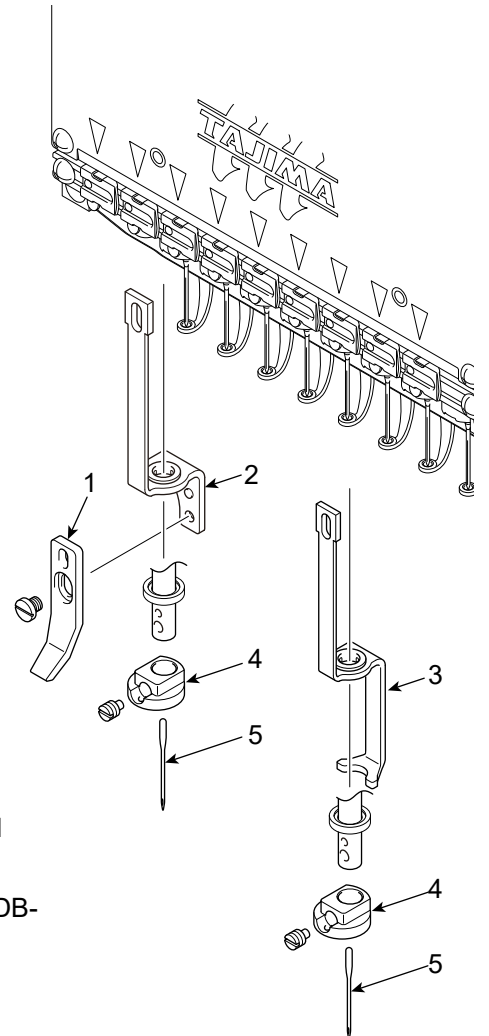

3. Setting and operation (TFMX, TFMX-C, TWMX-C, TLMX, TCMX)

3-1. Basic settings

This is the setting to make the Sequin device available for use.

3-1-1. Explanation on the screen

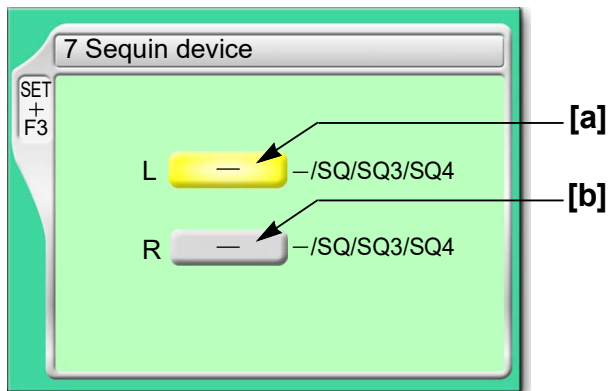

The screen display differs depending on machine type.

[a] Type of Sequin device equipped to left side

—: Not to use the device

SQ: High speed sequin device (not used)

SQ3: Sequin device III (Up/down-by-motor type)

SQ4: Sequin device IV (Up/down-by-air type)

Air compressor is required.

[b] Type of Sequin device equipped to the right side

The contents of settings are the same as [a].

3-1-2. How to operate

The following is the example of installing Sequin device IV at the left side.

(1) Set to main screen.

(2) To press F3 key while pressing SET

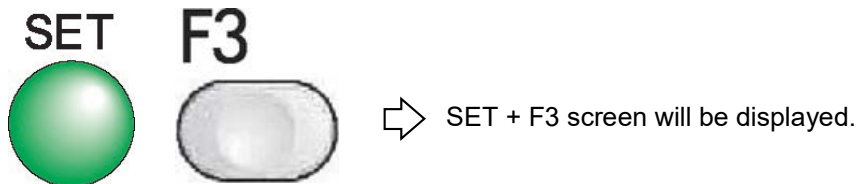

(3) Press F3 key to select "7 Sequin device"

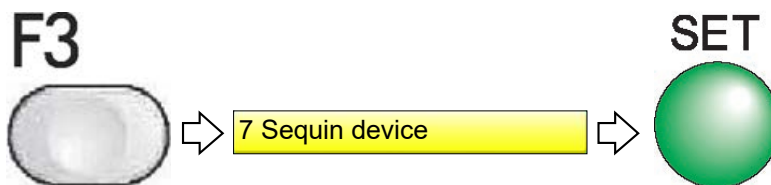

(4) To select type of sequin

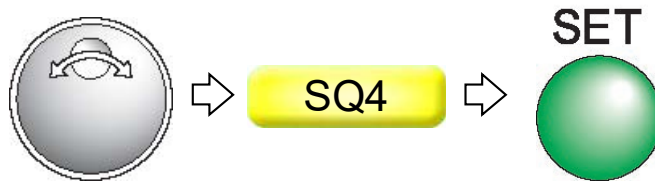

3-2. Setting of Air compressor

Set this function when sequin device IV is equipped.

3-2-1. Explanation on the screen



3-2-2. How to operate

⚠ CAUTION

ⓘ When installing sequin device IV, select "YES". Selecting "NO" will cause the sequin device to move down and damage the device and machine if the air pressure decreases in the middle of embroidery.

The following is the example of making Air compressor available for use.

- (1) Set to main screen.
- (2) To press F3 key while pressing SET



- (3) Press F3 key to select "3 Air pressure sensor"

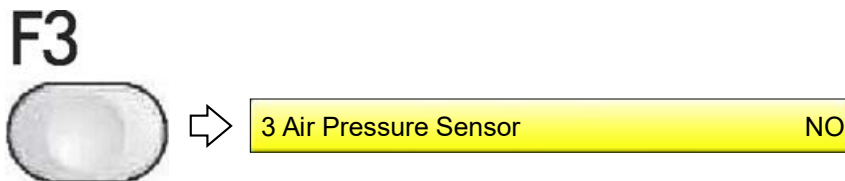

- (4) To use the air compressor

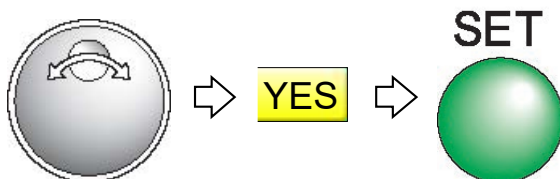

3-3. Setting of sequin chip feed amount

3-3-1. Explanation on the screen

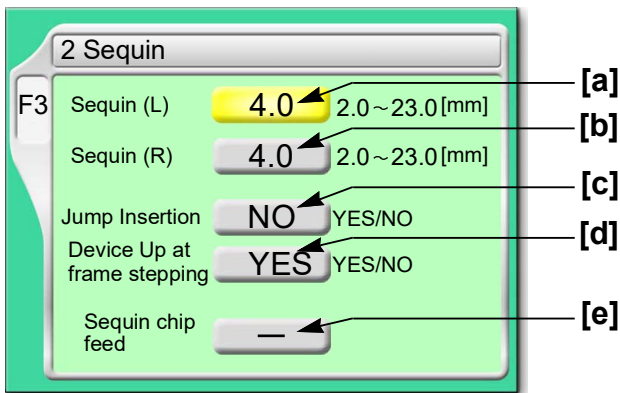

[a] Feed amount of sequin chips of device at left side

Select a value that adds about 1.0 to an external diameter of chip as a rough standard.

[b] Feed amount of sequin chips of the device at the right side

Select a value that adds about 1.0 to an external diameter of chip as a rough standard.

[c] Insertion of jump data when a sequin chip is sewn on

Select "YES" when sequin chips are not sewn effectually. However, productivity will be decreased.

YES: To perform

NO: Not to perform

[d] Moving up of device at frame stepping

YES: To perform

NO: Not to perform

! CAUTION

! Selecting "NO" will increase manufacturing efficiency. However, the device could interfere with the frame resulting in its breakage depending on design or frame type to use.

[e] Feed out sequin tip one by one by manual operation. (→p.53)

3-3-2. How to operate

This is an example of setting in the following conditions.

Feed amount of sequin chips of device at left side: 4.0

Insertion of jump data: To perform

Moving up of device at frame stepping: To perform

(1) Press F3 key to select "2 Sequin"

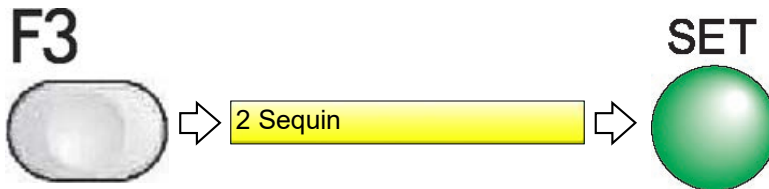

(2) To select feed amount of sequin chips of device at left side



(3) To insert jump data



(4) To move up device at frame stepping



3-4. Sequin chip feed

Feed out sequin tip one by one by manual operation. Use it when adjusting the sequin cut face.

3-4-1. Explanation on the screen

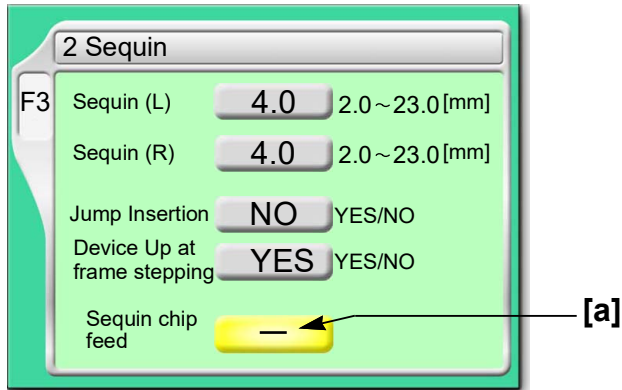

[a] To feed sequin chips one by one

The feed amount is the value selected by sequin (L) and sequin (R).

3-4-2. How to operate

CAUTION

 When performing this operation, do not put your hands etc. around the needle bar case. Moving needle bar case could injure you.

The following is the example of feeding out sequin chips of the right side Sequin device one by one.

- (1) Set the tension base switch to "Middle" position. (It should not be suspended head.)
- (2) Press F3 key to select "2 Sequin"

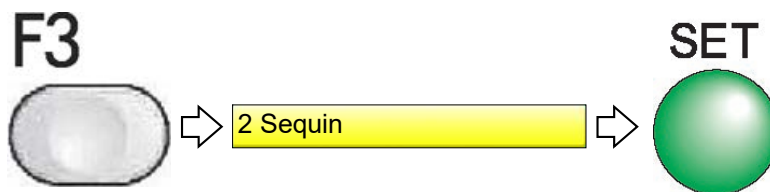

- (3) To move the cursor to "Sequin chip feed"



- (4) To select R (Right-side Sequin device)

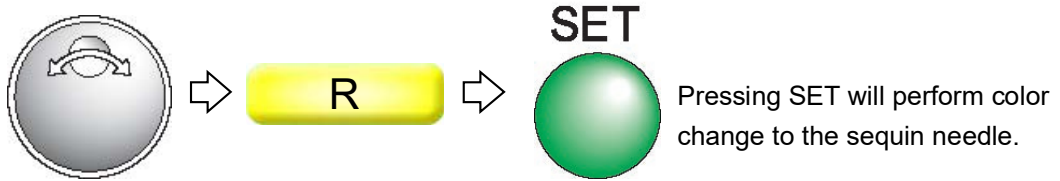

- (5) To feed sequin chips

Every time raising the tension base switch will feed out sequin chips one by one.

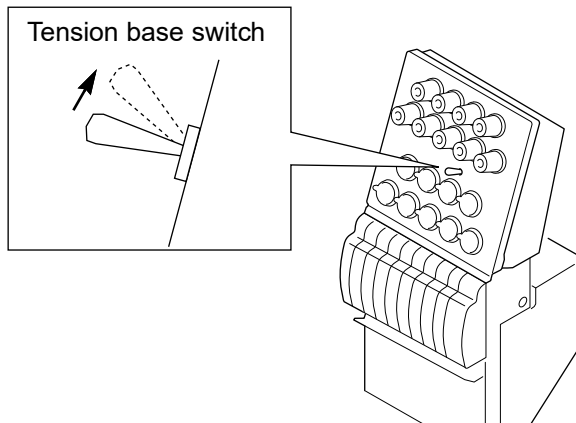

[For single head machine]

Pressing the frame travel key (up-arrow key) each time will feed out a sequin chip one by one.



3-5. To raise/lower Sequin device at all heads together in a batch

Make sequin devices of all heads move up/down all together by manual operation.

⚠ CAUTION

⊘ When performing this operation, do not put your hands, etc. under the needle or on the machine table. If your hands are under the needle or on the machine table, you could be injured by the moving up/down of sequin device.

3-5-1. Explanation on the screen



3-5-2. How to operate

The below explanation is the example of moving up the Sequin device.

(1) To open screen

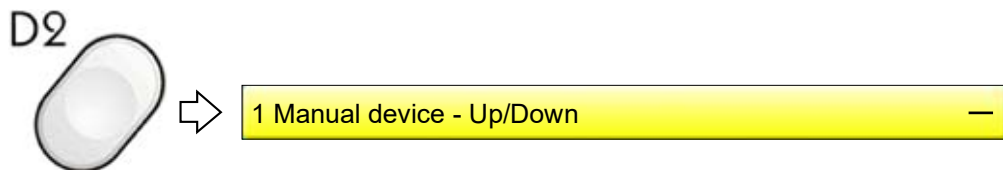

(2) To raise the Sequin device

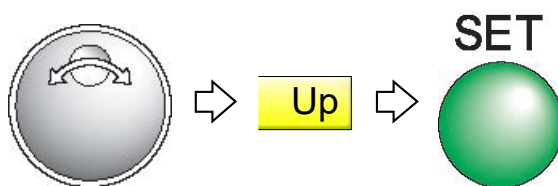

4. Setting and operation (TMCP, TMCS)

4-1. Basic settings

To actuate the device, it is necessary to set the following parameters on the machine side.

When the device is mounted to the right side of the head: Select "1 Sequin device (R)".

Refer to "3-2. Basic settings (→p.31)".

When the device is mounted to the left side of the head: Select "2 Sequin device (L)".

Refer to "3-2. Basic settings (→p.31)".

4-2. Setting of Air compressor

Set this function when sequin device IV is equipped.

Refer to "3-3. Setting of Air compressor (→p.32)".

4-3. Setting of sequin chip feed amount

Rough standard of sequin feed amount is +1.0 mm for sequin size.

Refer to "3-4. Setting of sequin chip feed amount (→p.32)".

4-4. Insertion of Jump at Sequin

Select whether one stitch of non-data jump code is inserted before or after sequin output or not.

Refer to "3-5. Insertion of Jump at Sequin (→p.33)".

4-5. Auto lifting - Sequin device

Select whether sequin device moves up automatically or retracts at ATH working by frame stepping.

Refer to "3-6. Auto lifting - Sequin device (→p.34)".

4-6. Sequin chip feed

It is possible to feed sequin chips by operation of the tension base switch.

Refer to "3-7. Sequin chip feed (→p.34)".

4-7. To raise/lower Sequin device at all heads together in a batch

Make sequin devices of all heads move up/down all together by manual operation.

Refer to "3-8. To raise/lower Sequin device at all heads together in a batch (→p.36)".

5. Setting and operation (TMBP2)

5-1. Basic settings

To actuate the device, it is necessary to set the following parameters on the machine side.

Refer to "3-2. Basic settings (→p.31)".

5-2. Setting of Air compressor

Set this function when sequin device IV is equipped.

Refer to "3-3. Setting of Air compressor (→p.32)".

5-3. Setting of sequin chip feed amount

Rough standard of sequin feed amount is +1.0 mm for sequin size.

Refer to "3-4. Setting of sequin chip feed amount (→p.32)".

5-4. Insertion of Jump at Sequin

Select whether one stitch of non-data jump code is inserted after sequin output or not.

Refer to "3-5. Insertion of Jump at Sequin (→p.33)".

5-5. Auto lifting - Sequin device

Select whether sequin device moves up automatically at ATH working by frame stepping.

Refer to "3-6. Auto lifting - Sequin device (→p.34)".

5-6. Sequin chip feed

It is possible to feed sequin chips by operation of the tension base switch.

Refer to "3-7. Sequin chip feed (→p.34)".

5-7. Up/down operation

Raise/lower sequin device by manual operation.

Refer to "3-8. To raise/lower Sequin device at all heads together in a batch (→p.36)".

6. Replacement of parts (from standard spec. to wide range spec.)

When changing from 2 to 9 mm sequin (standard spec.) to 10 to 22 mm sequin (wide range spec.), replace the parts by the following procedure.

6-1. Replacement of parts near needle

(1) Remove the screw 1, and detach the face plate 2.



(2) Remove the screw 1 and remove the upper thread locking device.



- (3) Remove the screw 1 and 2, and detach the sequin presser foot base 3, the damper ring 4, the sequin needle clamp 5, and the needle 6.

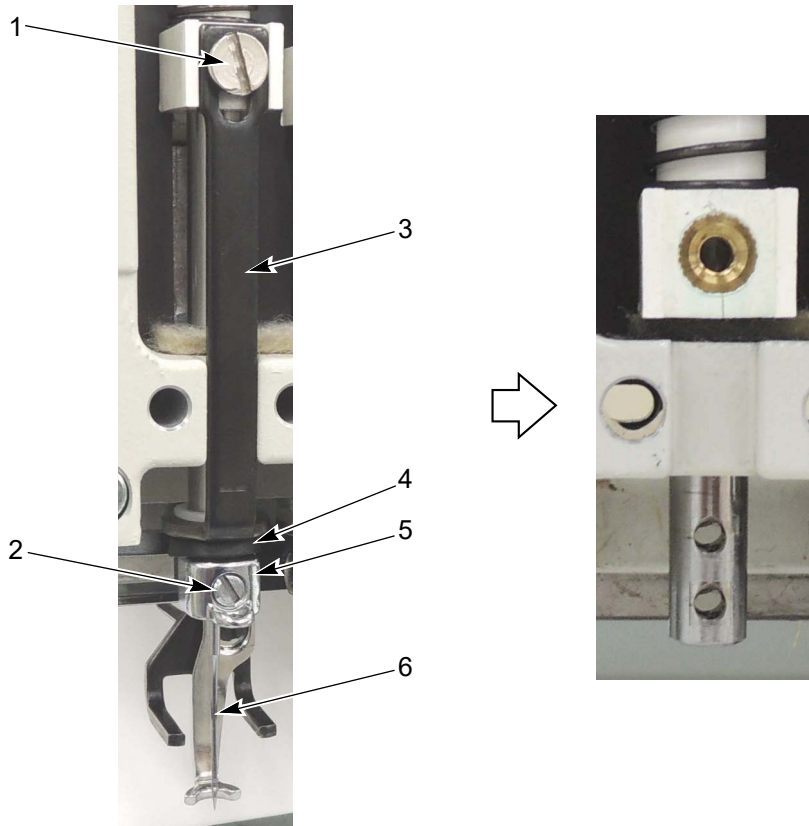

- (4) For TMCP, TMCS, TFMX, TWMX-C, TMBP2, attach the cap presser foot 2 to the presser foot base 1 with the screw 3.
For the screw 3, use the screw which is used in the sequin presser foot base by the previous procedure.
Attach the cap presser foot 2 to the lowest position for the elongated hole 4.

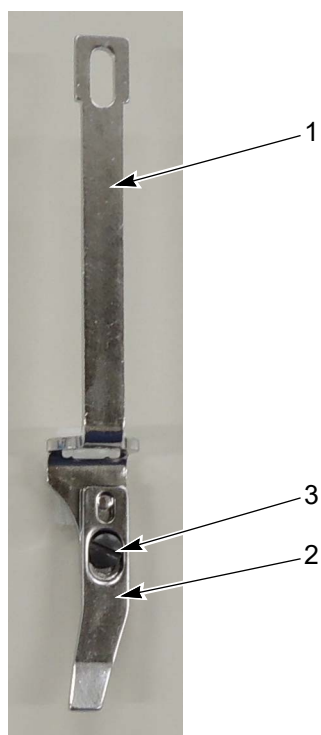

For TLMX and TCMX, the parts to be used are different. Replace the parts by referring below.

2. Wide range spec. (→p.47)

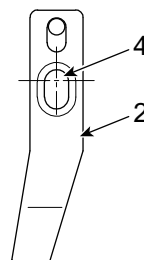

(5) Attach the presser foot base 1 with the screw 2. Attach the damper ring 3.

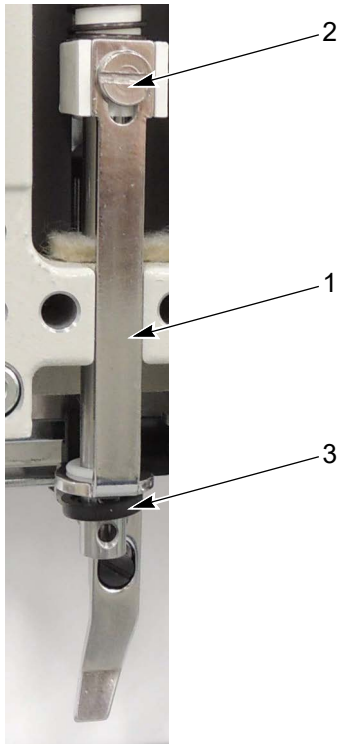

For the screw 2, use the screw which is detached by the previous procedure.

Pay attention to the up and down direction of the damper ring 3.

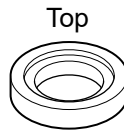

(6) Attach the needle clamp 1 of wide range spec. and needle 2 with the screw 3. Attach the needle clamp 1 of wide range spec. to the bottom hole 4 of the needle bar.

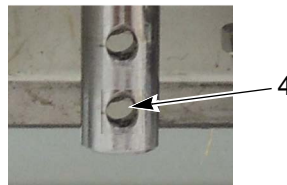
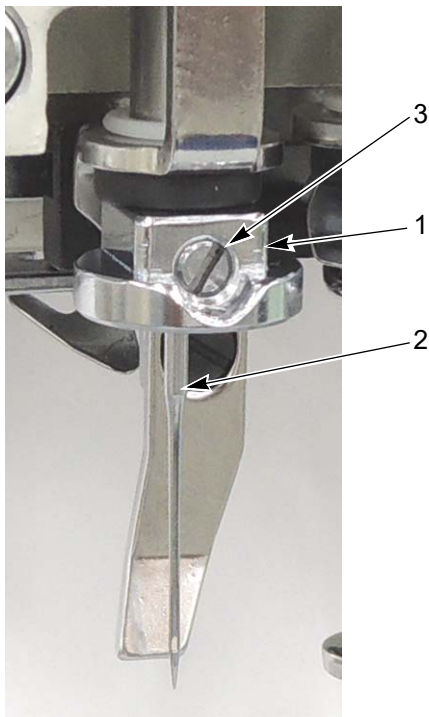

[Needle clamp of wide range spec.]

The photo is for 10 to 22 mm dead center sequin

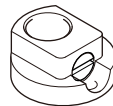

For 11 to 22 mm front hole eccentric sequin, top and bottom are reversed.

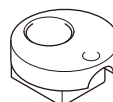

(7) Attach the upper thread locking device.

- (8) Set the main shaft angle to 178 degrees (Needle bar lower dead point).
- (9) Loosen the screw 3 to adjust the height of the presser foot base 4 so that the interval of the cap presser foot 1 and needle plate 2 becomes 1.2 mm. Loosen the screw 5 according to the fabric thickness, and adjust the height of cap presser foot 1.

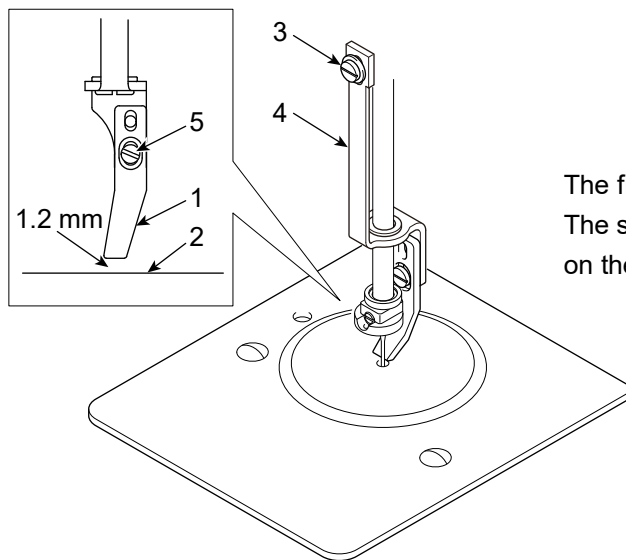

The figure shows the needle plate of TMCR.
The shape of the needle plate varies depending on the model.

- (10) Attach the face cover.

6-2. Replacement of lower unit parts

Referring to the following, replace the lower unit parts.

Refer to "4-2. Replacement of lower unit parts (→p.40)".

7. Replacement of parts (from wide range spec. to standard spec.)

When changing from 10 to 22 mm sequin (wide range spec.) to 2 to 9 mm sequin (standard spec.), replace the parts by the following procedure.

7-1. Replacement of parts near needle

(1) Remove the screw 1, and detach the face plate 2.



(2) Remove the screw 1 and remove the upper thread lockig device.



Replacement of parts (from wide range spec. to standard spec.)

- (3)** Remove the screw 1 and 2, and detach the presser foot 3 (for the name, refer below), damper ring 4, the needle clamp 5 of the wide range ,and the needle 6.

The shape and name of the presser foot base 3 differ depending on the model. (→p.47)

The photo is for the presser foot base.

Presser foot base: TMCP, TMCS, TFMX, TWMX-C, TMBP2

Sequin presser foot: TLMX, TCMX

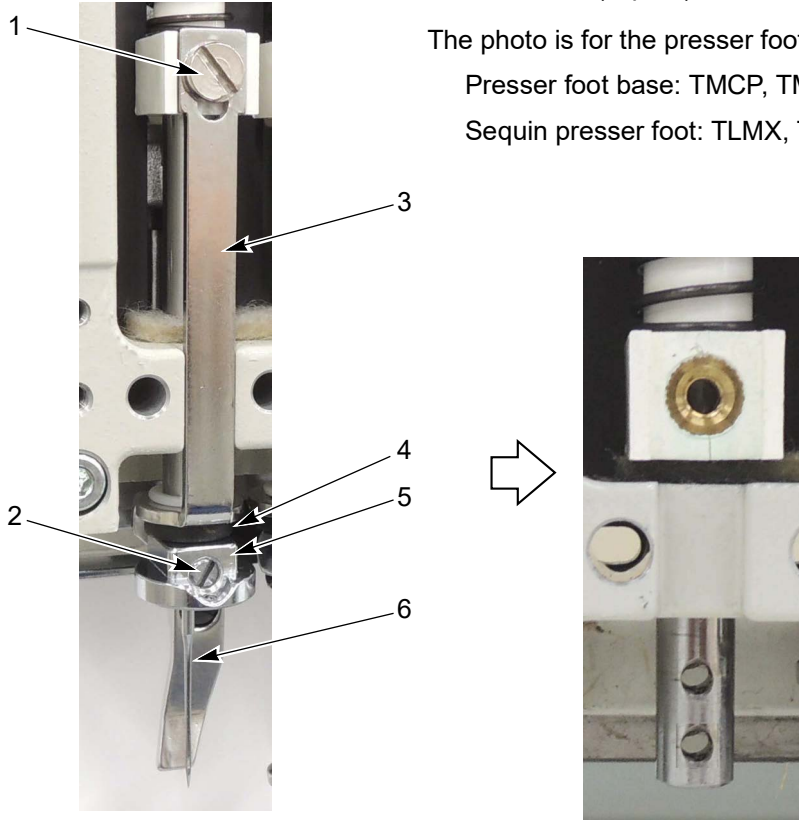

- (4)** Attach the sequin presser foot 2 to the sequin presser foot base 1 with the screw 3. Attach the sequin presser foot 2 to the lowest position for the elongated hole 4.

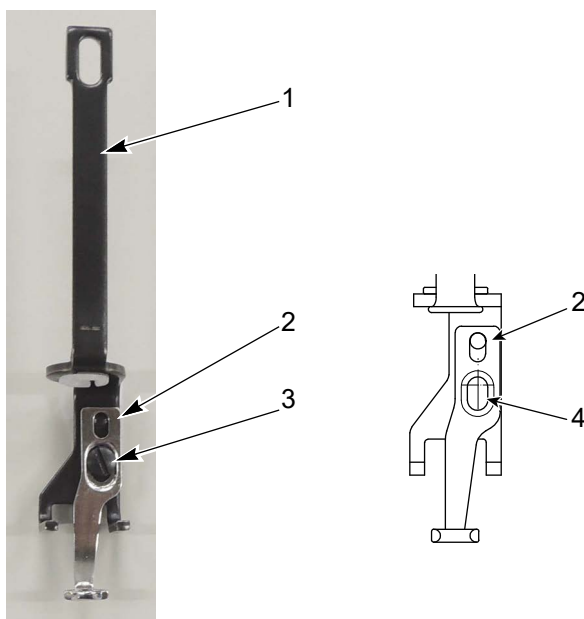

(5) Attach the sequin presser foot base 1 with the screw 2. Attach the damper ring 3.

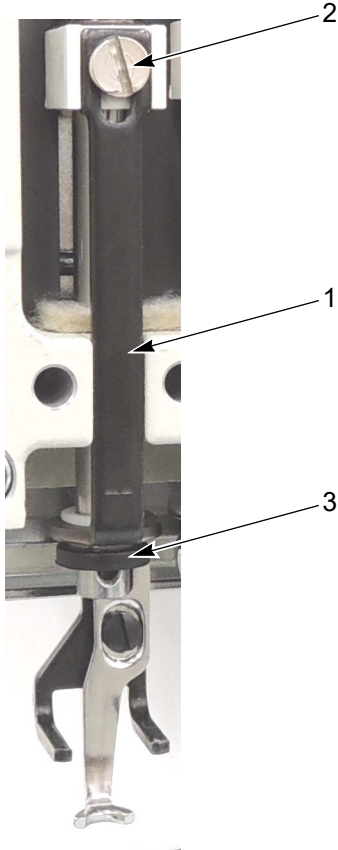

For the screw 2, use the screw which is detached by the previous procedure.

Pay attention to the up and down direction of the damper ring 3.

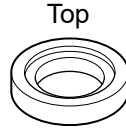

(6) Attach the sequin needle clamp 1 and the needle 2 with the screw 3.
Attach the sequin needle clamp 1 to the bottom hole 4 of the needle bar.

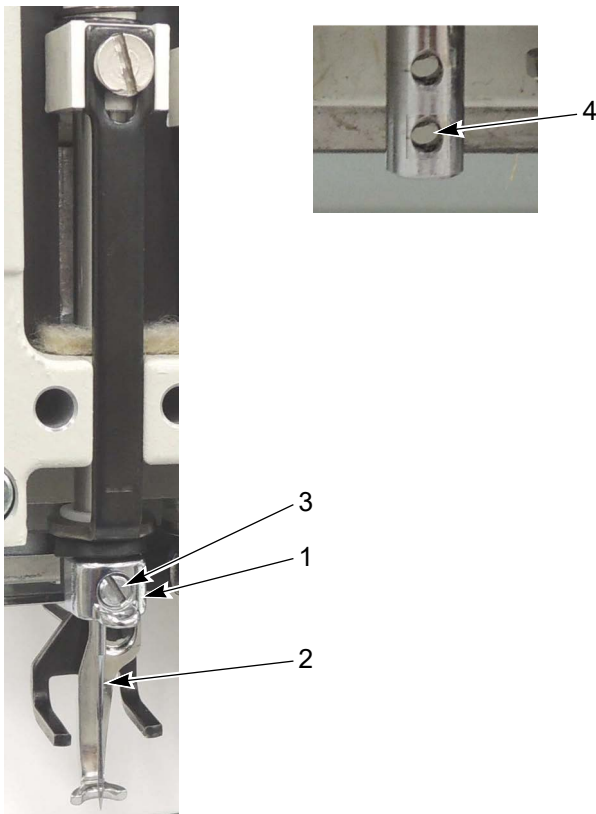

(7) Attach the upper thread locking device.

- (8) Set the main shaft angle to 178 degrees (Needle bar lower dead point).
- (9) Adjust the height of the sequin presser foot base 2 so that the bottom surface of the sequin needle clamp 1 and the bottom surface of the sequin presser foot base 2 are in the same position, and tighten the screws 3.
- Fix the sequin needle clamp 1 and the sequin presser foot base 2 so that they do not touch each other.

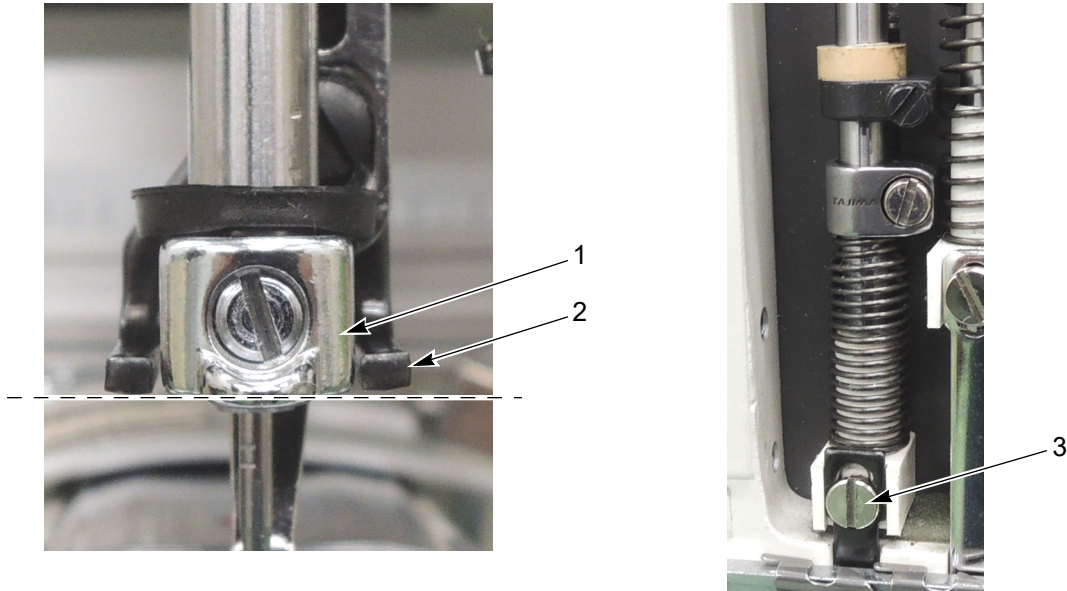

- (10) According to the fabric thickness, loosen the screw 1 to adjust the height of sequin presser foot 2.

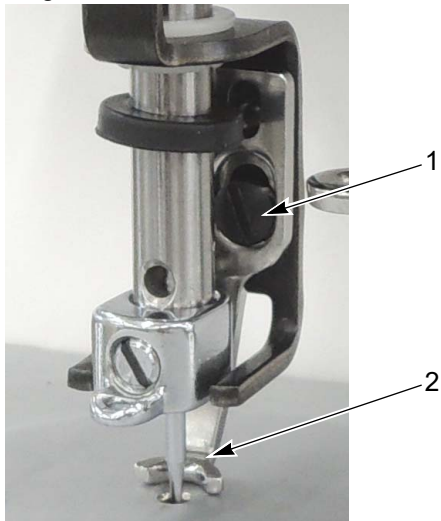

- (11) Attach the face cover.

- (12) Lower the sequin device and rotate the main shaft angle to 178 degrees, check that the sequin presser foot base 1 does not hit the the movable knife guard 2.

If interferes, check below.

Refer to "5-1. Height of device (→p.17)".

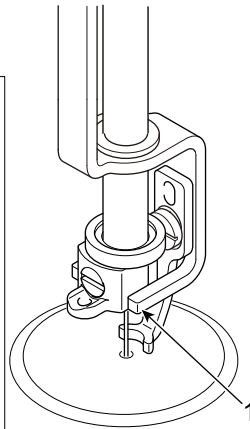
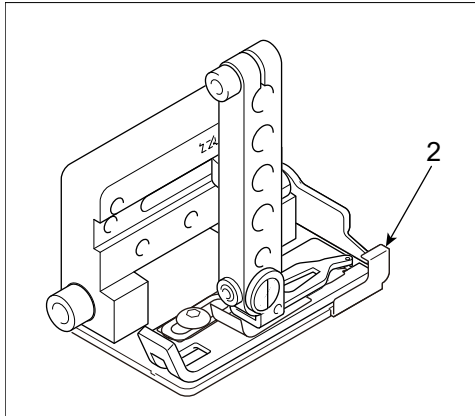

The figure shows the needle plate of TMCR. The shape of the needle plate varies depending on the model.

7-2. Replacement of lower unit parts

Referring to the following, replace the lower unit parts.

Refer to "5-2. Replacement of lower unit parts (→p.44)".

Chapter 5 Maintenance

1. Cleaning

Clean each part by using an air compressor.

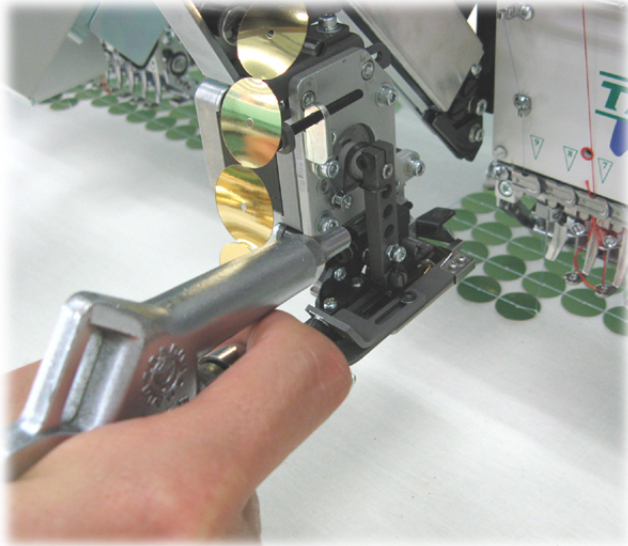

2. Lubrication

! WARNING

! To perform lubrication, turn OFF the power switch. You may sustain severe injuries by being caught in the machine.

! CAUTION

! When performing lubrication, use only Tajima's genuine TF oil or equivalent (ISO viscosity grade=VG20).

Lubrication cycle: Once/month

The figure is an example of the left side specification.

The lubricating spot is the same for the right side specification.

Wide range spec.

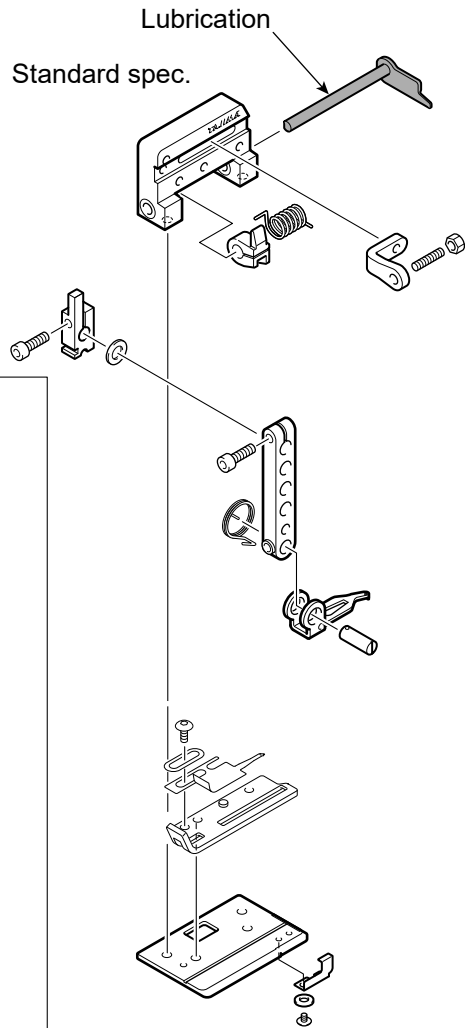
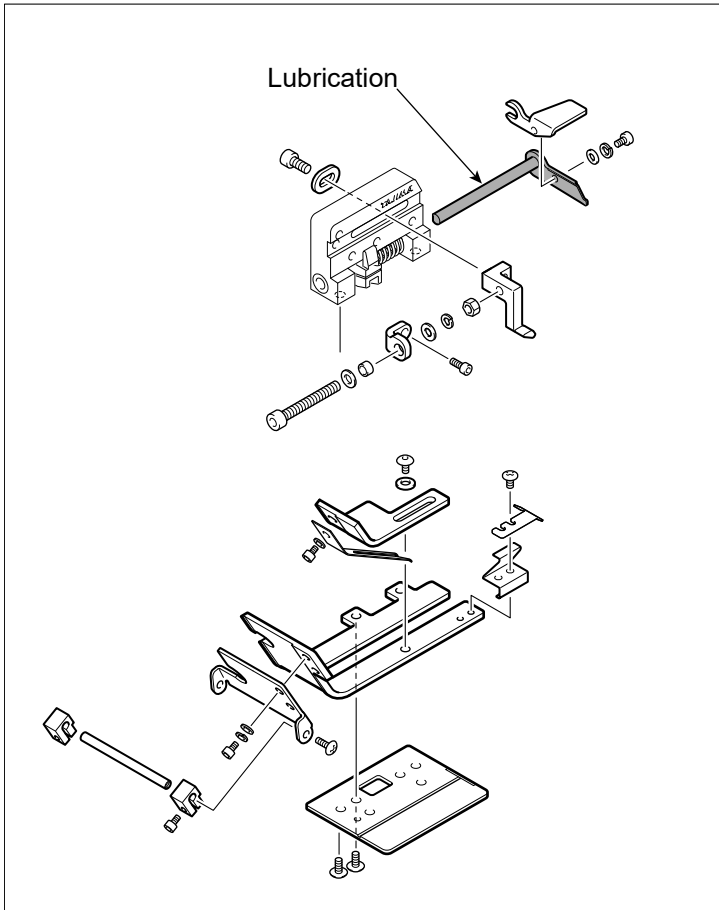

1st Edition July, 2018

6th Edition May, 2025

■ **Manufactured by : TISM Co.,Ltd.**

Address : NO.1800, Ushiyama-cho, Kasugai, Aichi -pref., 486-0901, Japan

■ **Distributed by : Tajima Industries Ltd.**

Address : NO.1800, Ushiyama-cho, Kasugai, Aichi -pref., 486-0901, Japan

- Copy, reprint, or reform of a part or whole of this manual without permission is prohibited.