

# **USER'S MANUAL**

## **AFC VIII**





## Foreword

This manual is a guidebook for the optional device “AFC VIII”.

Please read this manual thoroughly and operate the device after you understand the contents.

This manual may contain discrepancies in detailed specification as compared with the actual production.

If you have any question about this manual, consult your TAJIMA distributor.

Please keep this manual with care near the machine for quick reference.

**TISM Co.,Ltd.**

## Important safety instructions

Items that require your special attention on operation are specified below.



Indicates that there is a lot of danger of death or serious injuries<sup>[\*A]</sup> if the instruction is not observed.



Indicates that there is a likelihood of death or serious injuries<sup>[\*A]</sup> if the instruction is not observed.





Indicates a potentially hazardous situation which, if not avoided, may result in minor or moderate injury<sup>[\*B]</sup> or property damage.

[\*A] A condition caused by electric shock, injury, fracture of a bone, etc., that leads to aftereffects, or an injury that necessitates hospitalization or visits to a hospital over a long period.

[\*B] An injury that does not necessitate hospitalization or visit to a hospital over a long period.

 : Prohibited items

 : Items that may cause electric shock if not observed

 : Items that must be followed carefully to ensure safe operation

## Chapter 1 Configuration

- 1. Name of each part..... 1
- 2. automatic change of fabric to be stretched by the device ..... 2

## Chapter 2 Preparation

- 1. Air check..... 3
- 2. Fabric stand (rear)..... 3
  - 2-1. When setting one piece of fabric.....3
  - 2-2. When quilting is set.....4
- 3. Passing of fabric..... 6

## Chapter 3 Setting and operation (TLMX, TCWM)

- 1. Checking items before using the device..... 7
  - 1-1. AFC setting ..... 7
  - 1-2. Frame Type ..... 7
  - 1-3. Air Pressure Sensor ..... 8
  - 1-4. Stop at Lower D.Point..... 8
- 2. To open/close the frame manually ..... 9
  - 2-1. To open/close the selected frame .....9
  - 2-2. To open/close all frames by consecutive movements ..... 10

## Chapter 4 Setting and operation (TMCR, TMCP)

- 1. Checking items before using the device..... 11
  - 1-1. AFC setting ..... 11
  - 1-2. Stop at Lower D.Point..... 11
  - 1-3. Return Frame at Lower D. Point ..... 12
  - 1-4. Air Pressure Sensor ..... 12
  - 1-5. AFC automatic control ..... 13
- 2. To open/close the frame manually ..... 14

## **Chapter 5** Adjustment of each part

1. Adjustment of fabric stretching amount .....	15
1-1. Lengthwise (Y-axis) sash .....	15
1-2. Horizontal (X-axis) sash .....	15
1-3. Table presser .....	16
2. Adjustment of lengthwise (Y-axis) sash .....	17
2-1. Height of lengthwise (Y-axis) sash .....	17
2-2. Position adjustment of the vertical (Y-axis) sash according to fabric width .....	18
2-3. Extension of air pipe .....	18

## **Chapter 6** Attaching/detaching of needle bar case, dummy case

1. Detaching .....	19
1-1. Needle bar case .....	19
1-2. Dummy case .....	20
2. Attaching .....	21
2-1. Needle bar case .....	21
2-2. Dummy case .....	22
3. Replacement of needle plate .....	23

# Chapter 1 Configuration

## 1. Name of each part

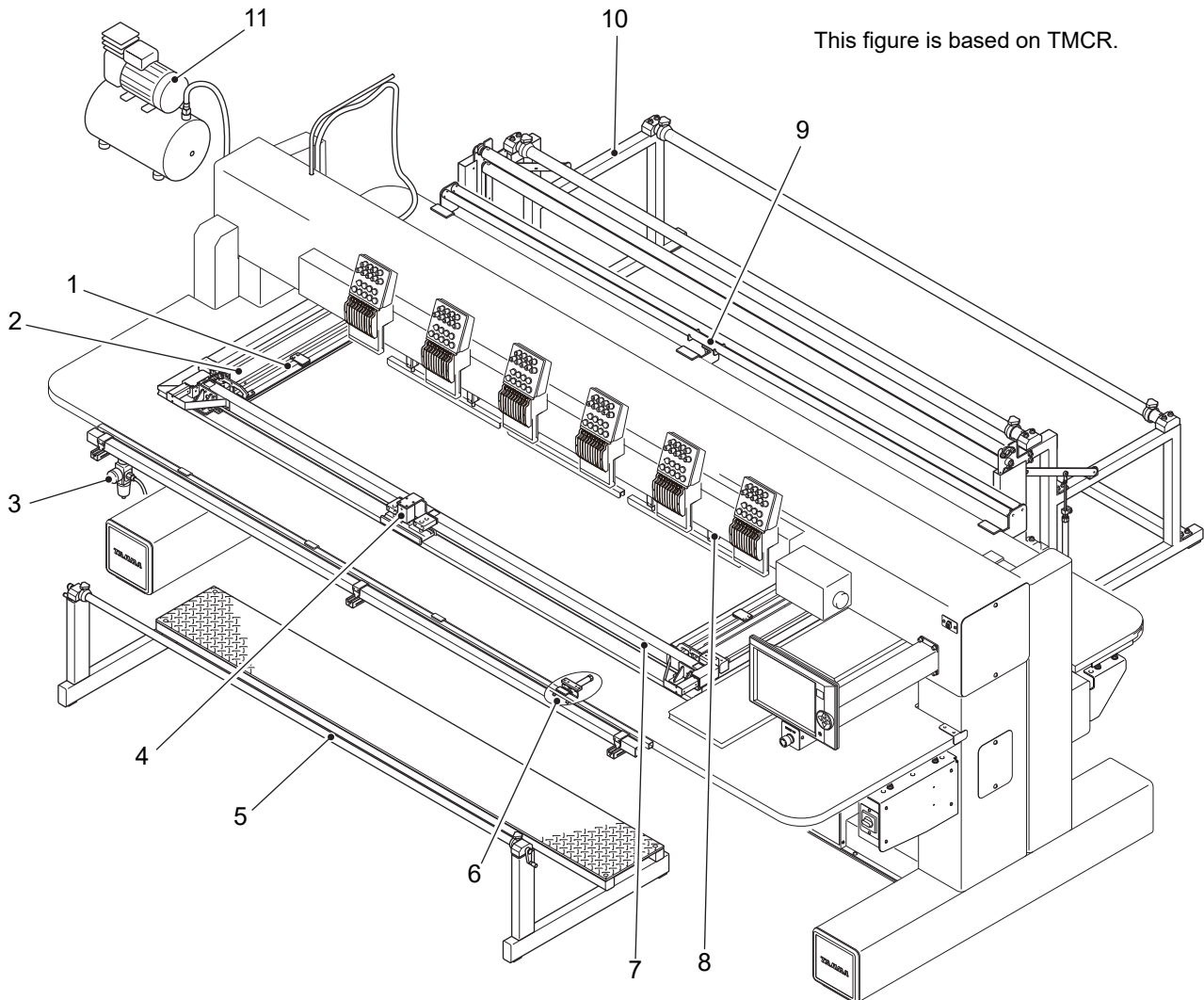

- |                             |                             |
|-----------------------------|-----------------------------|
| 1. Lengthwise (Y-axis) sash | 7. Horizontal (X-axis) sash |
| 2. Fabric stretching        | 8. Fabric presser           |
| 3. Air regulator            | 9. Fabric guide             |
| 4. Anti-vibration stopper   | 10. Fabric stand (rear)     |
| 5. Fabric stand (front)     | 11. Air compressor          |
| 6. Table presser            |                             |

## 2. automatic change of fabric to be stretched by the device

Embroidery stops at an end code or an AFC frame feed code and the device feeds the fabric and changes the stretching position automatically by the following procedure.



When Stop at Lower D. Point is set to "Yes", the machine will stop in the state that needles stick in the fabric.

- (1)** The table presser (1 in the right figure) and the fabric presser 2 will close to cause the fabric to be fixed. In addition, the center of the fabric guide 3 will move up. This condition is referred to as valve 1 (V1) is in the state of ON.



At this moment, the feed roller 4 of the fabric stand (rear) will move down. On the contrary, when V1 is turned "OFF", 4 will move up.

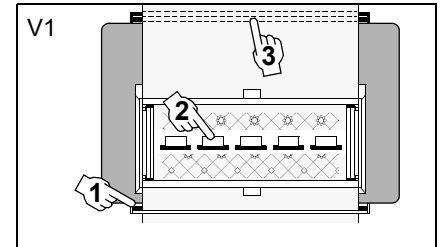
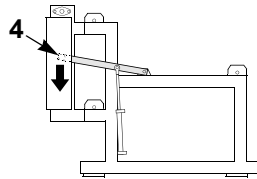

- (2)** The fabric stretchers 5 will be released. This condition is referred to as valve 2 (V2) is in the state of ON.

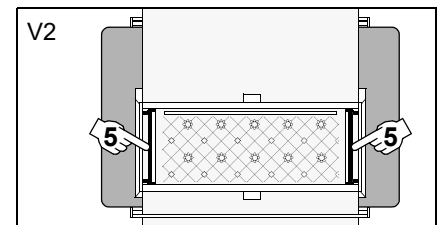
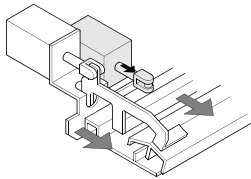

- (3)** The horizontal (X-axis) sashes 6 will be released. This condition is referred to as valve 3 (V3) is in the state of ON.

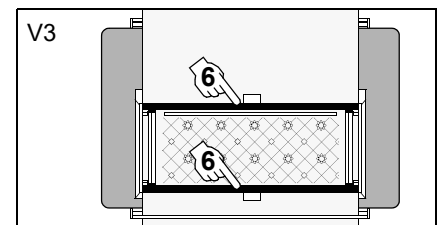
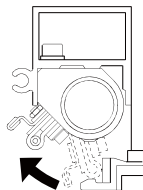

- (4)** The lengthwise (Y-axis) sashes 7 and the anti-vibration stopper will be released. This condition is referred to as valve 4 (V4) is in the state of ON.

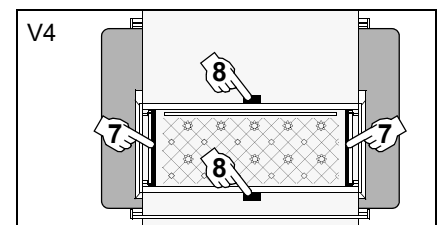
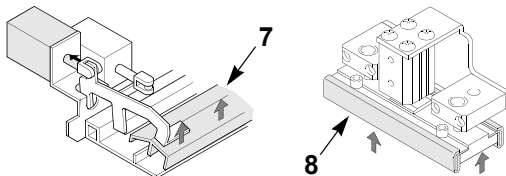

- (5)** The frame will move to the start position.

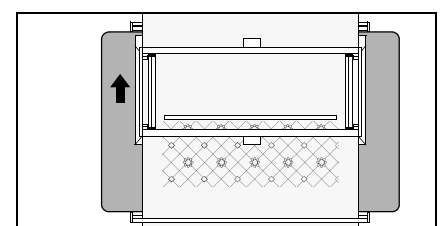

- (6)** Valves will be turned "OFF" in the order of 4, 3, 2, and 1 to stretch the fabric.

- (7)** The machine will start automatically.

## Chapter 2 Preparation

### 1. Air check

Check if the indicator 3 indicates 0.55 in the state that the air compressor (1 in the figure below) is connected with the air regulator 2 of embroidery machine. When adjustment is necessary, pull up the cap 4 and turn 4 in order to adjust 3 to 0.55.

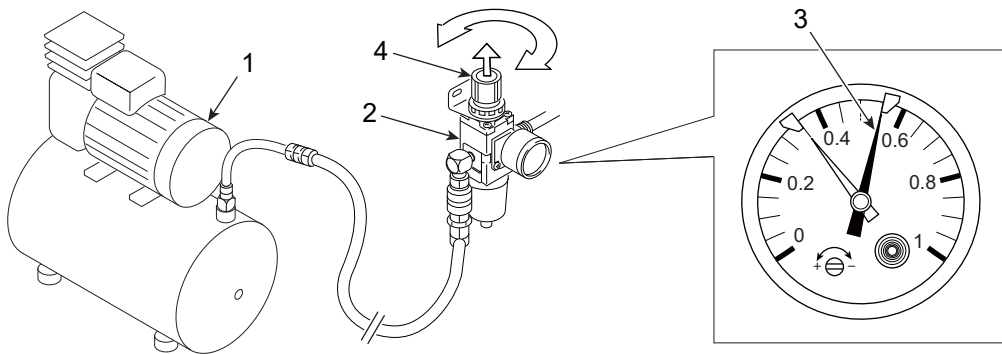

### 2. Fabric stand (rear)

#### 2-1. When setting one piece of fabric

- (1) Remove the screw 1 to detach the cover 2.
- (2) Loosen the knob 3 to detach the holder 4.
- (3) Set the fabric 5 and make the holders 4 touch both ends of the fabric, and tighten the knobs 3.
- (4) Return the cover 2 and tighten the screws 1.



Tighten the screw 1 strongly to apply tension to the shaft. No tension will cause the fabric 5 to be pulled excessively and it will be not possible to stretch fabric. However, do not tighten 1 too much. The shaft cannot rotate.

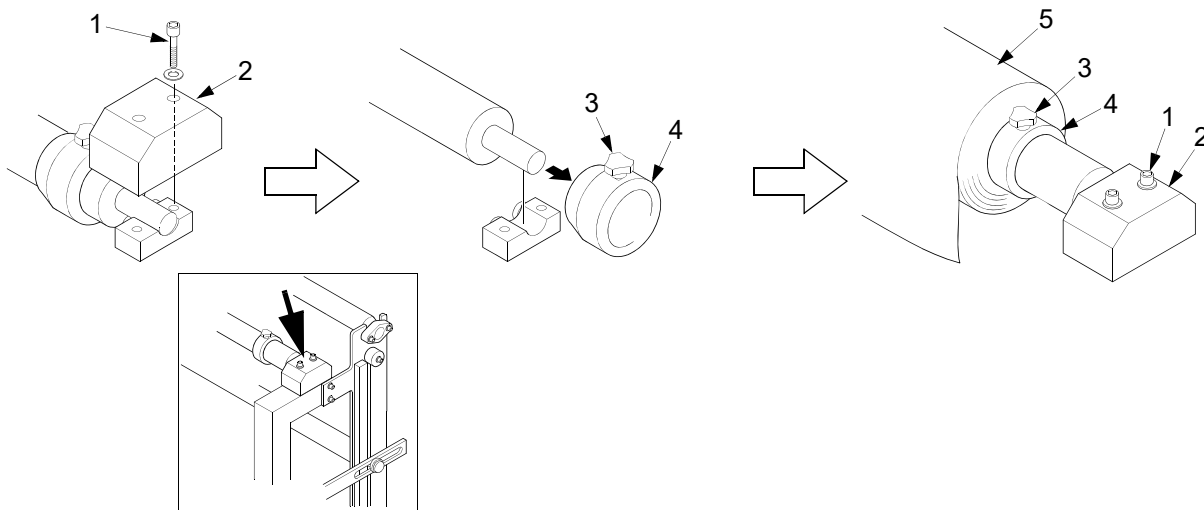

- (5) Pass the fabric 5 from under the feed roller 6 and through the guide roller 7 to the table.
- (6) Decide the height of the stopper 8 so that the feed roller 6 stops at 1/2 of fabric feed amount, and then tighten the screw 9.
- Example:  
 When fabric feed amount is 400 mm, the height of 8 is 200 mm. Adjust the value by using the traverse scale 10.
- (7) Adjust the lower speed controller 11 so that the feed roller 6 moves down slowly in about four seconds during automatic frame feed.

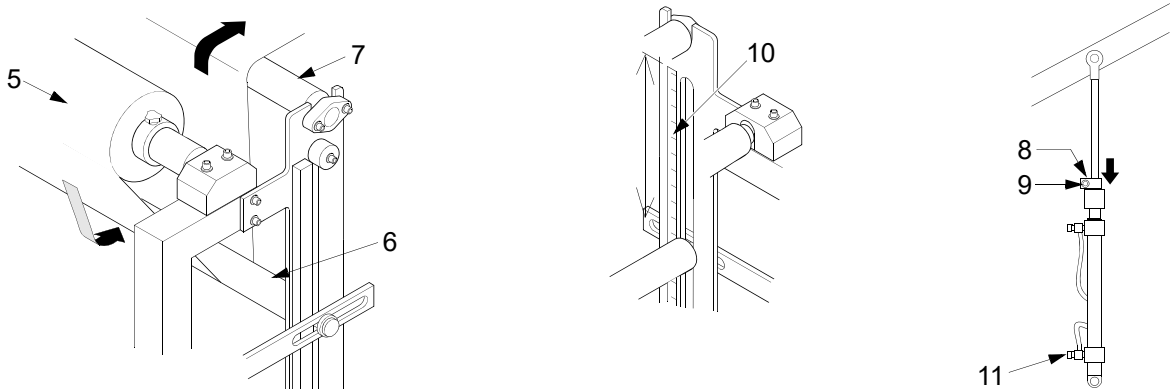

## 2-2. When quilting is set

- (1) Remove the screw (1 in the figure below) to detach the cover 2.
- (2) Loosen the knob 3 to detach the holder 4.
- (3) Set the under fabric 6, upper fabric 7 and inner cotton 8 to the shaft 5.



Do not mistake rotating direction of the fabric 6, 7, and 8 (Refer to the arrows).

- (4) Push the holders 4 into the both ends of the shaft 5, and tighten the knobs 3.
- (5) Return the cover 2 and tighten the screws 1.



Tighten the screw 1 strongly to apply tension to the shaft. No tension will cause the fabric 6, 7 and 8 to be pulled excessively and it will be not possible to stretch fabric. However, do not tighten 1 too much. The shaft cannot rotate.

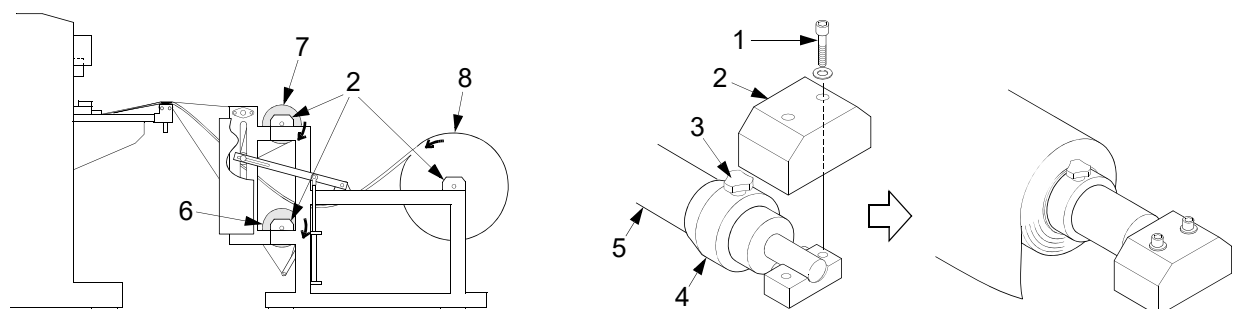

- (6) Pass the under fabric 6 to the table from under the tension bar 9.
- (7) Pass the interlining cotton 8 under the feed roller 10 to the table.
- (8) Pass the upper fabric 7 from under the feed roller 10 and through the guide roller 11 to the table.
- (9) Decide the height of the stopper 12 so that the feed roller 10 stops at 1/2 of fabric feed amount, and then tighten the screw 13.
- Example:  
When fabric feed amount is 400 mm, the height of 12 is 200 mm. Adjust the value by using the traverse scale 14.
- (10) Adjust the lower speed controller 15 so that the feed roller 10 moves down slowly in about four seconds during automatic frame feed.

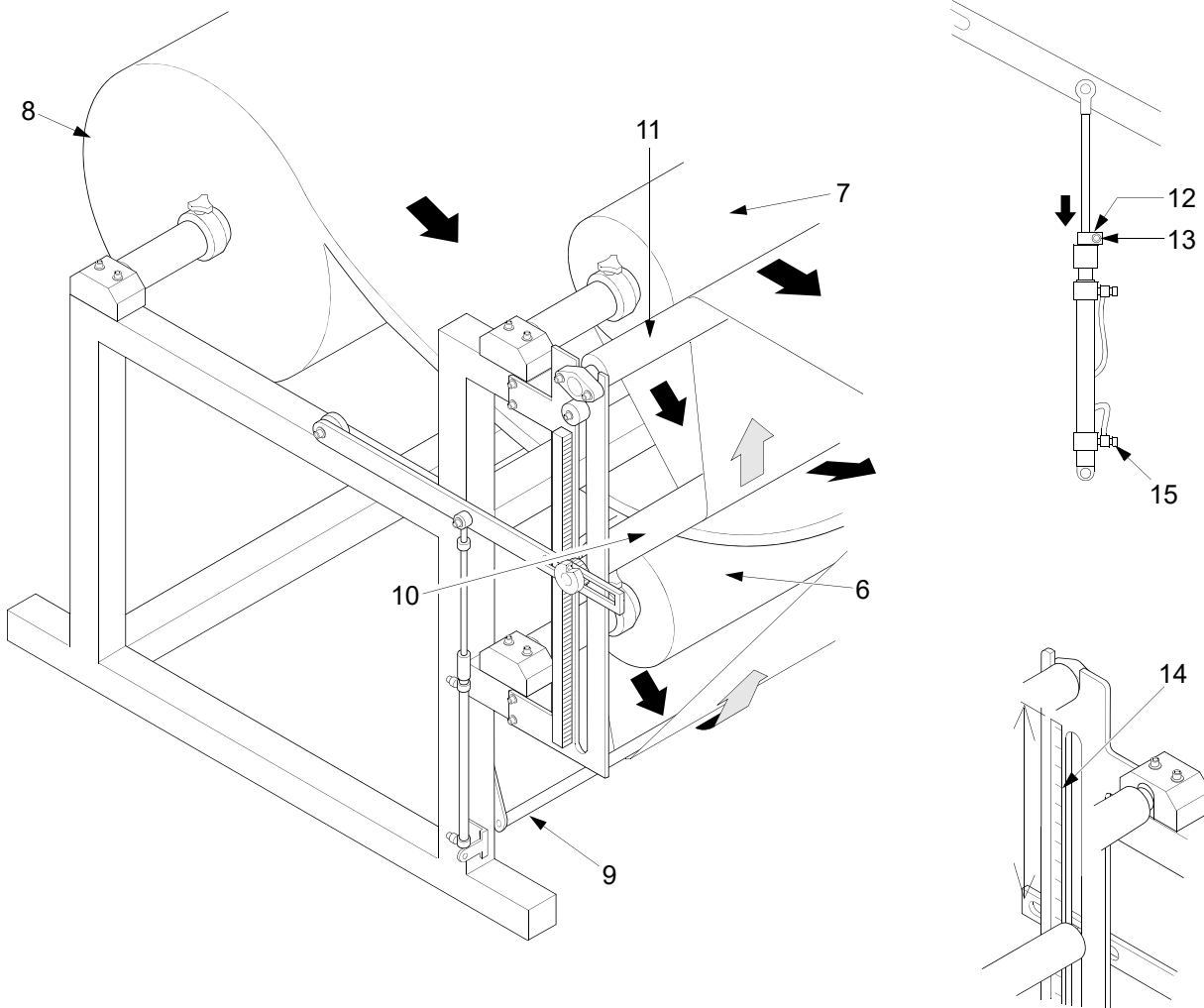

### 3. Passing of fabric

- (1) Pass the fabric (1 in the figure below) over the fabric guide 2, and pass the fabric between the horizontal sashes 3 and 4.
- (2) Pass the fabric 1 to the table presser 5.
- (3) Adjust the position of the fabric 1, and stretch the fabric by the following operation.  
 TLMX、TCWM: 2-2. To open/close all frames by consecutive movements of p.10 → “Down”  
 TMCR、TMCP: 2. To open/close the frame manually of p.14 → “4321 OFF”

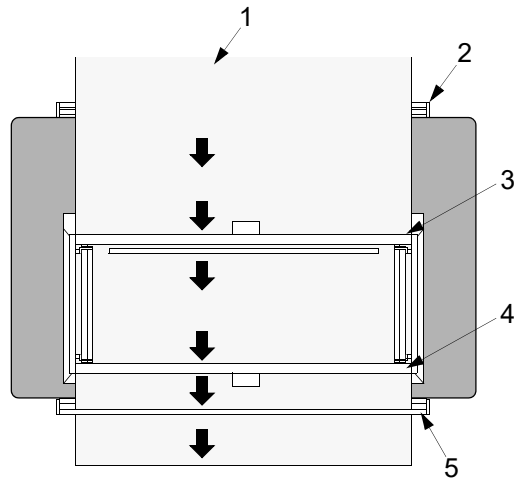

Roll up the sewn fabric 1 by using the handle 6.

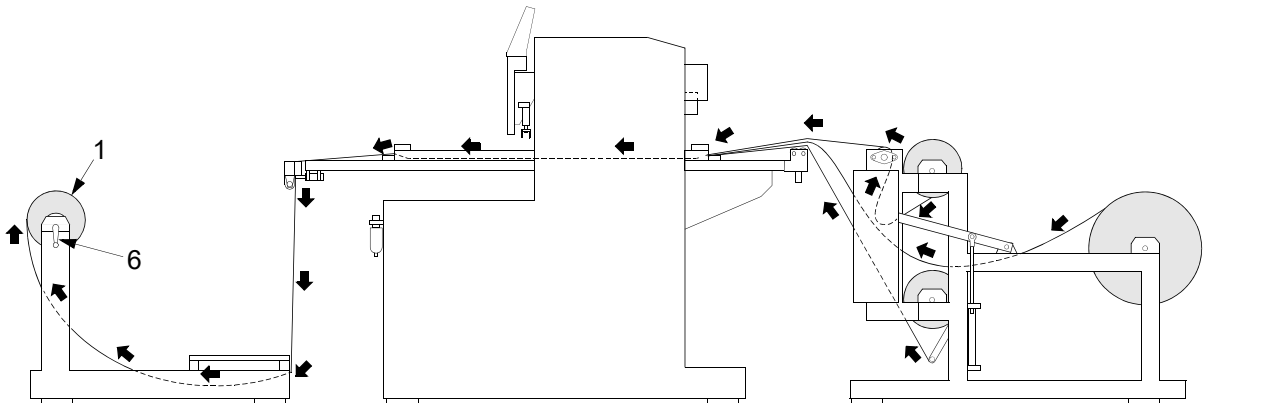

## Chapter 3 Setting and operation (TLMX, TCWM)

### 1. Checking items before using the device

Before you use AFC at the first time after the installation, check the following settings "1-1." to "1-4.". These values will return to the initial ones after installing the software. Therefore, perform setting again.

#### 1-1. AFC setting

This setting makes AFC available for use.

(1) To switch screen

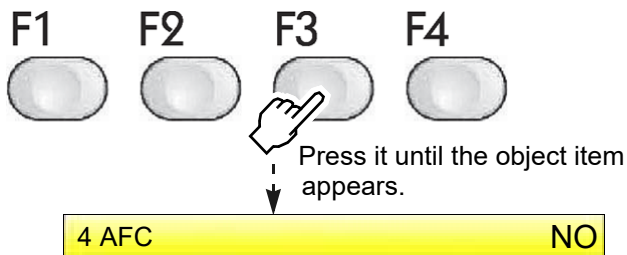

(2) Select "YES" and press [SET].



#### 1-2. Frame Type

Change drive mode according to the frame to use.

(1) To call the screen

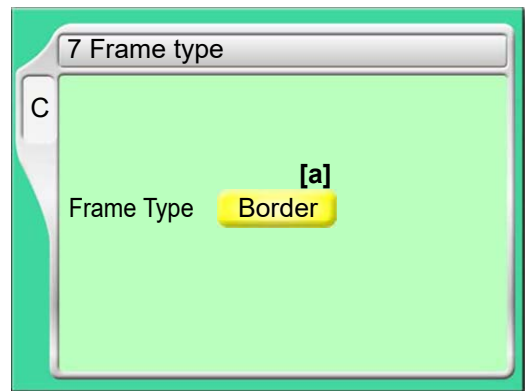
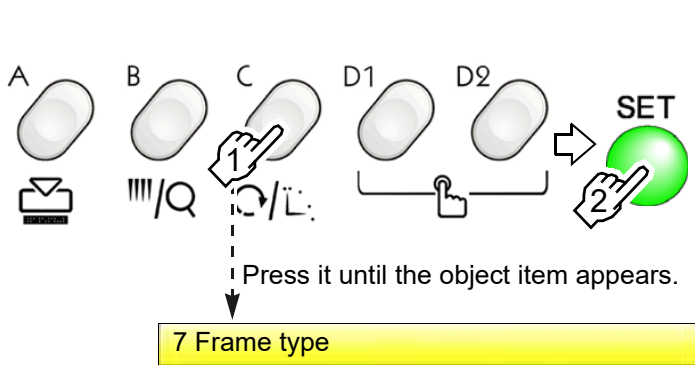

<Screen>

[a] Border frame, AFC

(2) Select "AFC", and turn ON the power after pressing [SET].

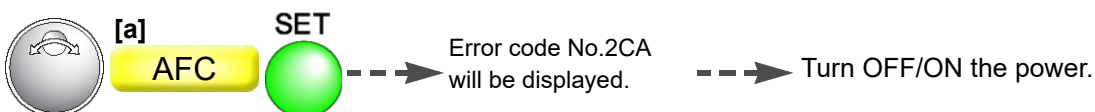

### 1-3. Air Pressure Sensor

This setting will stop the machine when air pressure of an air compressor decreases.

**⚠ Caution**

**!** Select "YES" for this value. If you select NO, the device and/or the machine could be damaged because the frame does not open/close normally when air pressure is decreased in the middle of embroidery.

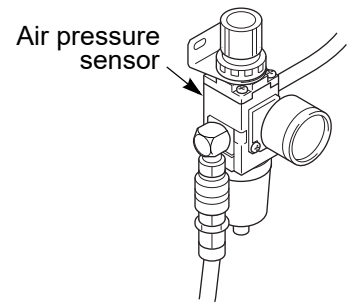

**(1)** To perform the following operations from the main screen

**SET** Press [F3] while pressing [SET]. **F3**

---

**F1** **F2** **F3** **F4**

**3** To the object item Press [F3].

3 Air Pressure Sensor
NO

**(2)** Select "YES" and press [SET].



### 1-4. Stop at Lower D.Point

This setting makes the machine stop with needle stuck in the material at the end of a design.



This function can minimize design displacement at frame travel in continuous design by using AFC frame.

**(1)** To switch screen

**A** **B** **C** **D1** **D2**

Press it until the object item appears.

10 Stop at Lower D. Point
NO

**(2)** Select "YES" and press [SET].



## 2. To open/close the frame manually

### 2-1. To open/close the selected frame

Turn ON/OFF the selected valve (V1 to V4) to open/close the frame.



It is possible to set only when AFC is set to "YES" ( → p.7).

#### (1) To call the screen

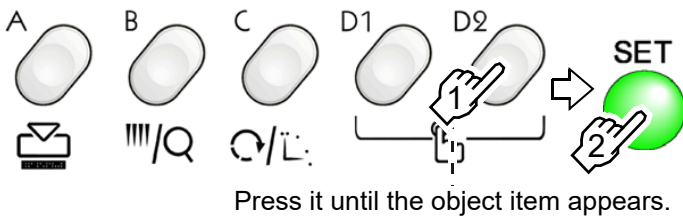

6 Manual AFC Valve Switching

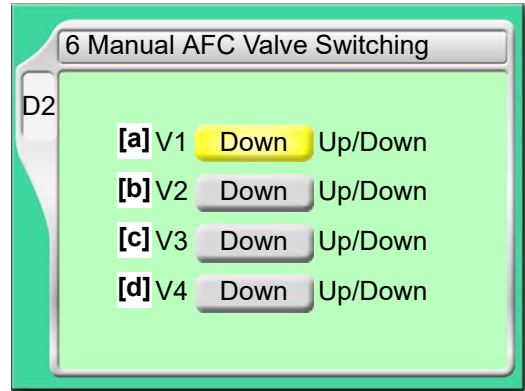

<Screen>

- [a] V1:** table presser  
UP: releasing fabric  
Down: fixing fabric
- [b] V2:** fabric stretching  
UP: releasing fabric  
Down: stretching fabric
- [c] V3:** crosswise sash  
UP: releasing fabric  
Down: fixing fabric
- [d] V4:** Lengthwise sash  
UP: releasing fabric  
Down: fixing fabric

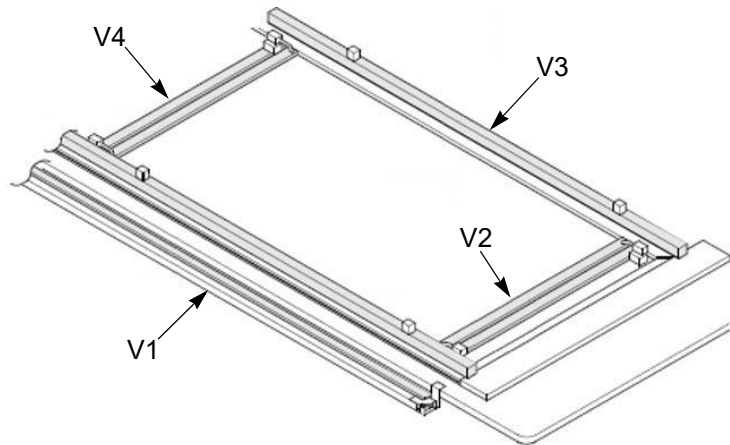

#### (2) To set

Select the valve to open/close

by  / .



### Caution

 When performing this working, do not put your hands under the needle or on the table. You could be injured by opening/closing frame.

### 2-2. To open/close all frames by consecutive movements

Make the frame open/close by activating valves V1 to V4 consecutively.

**! Caution**

⊘ When performing this working, do not put your hands under the needle or on the table. You could be injured by opening/closing frame.



It is possible to set only when AFC is set to "YES" ( → p.7).

(1) To switch screen .....

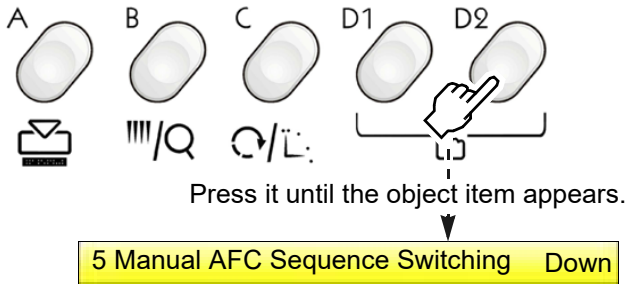

(2) Select "O" to [SET].

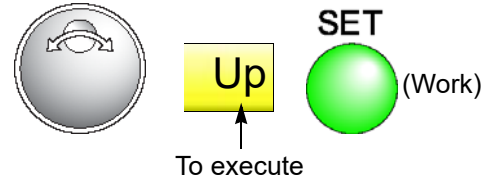

Up: The frame will open in the order from V1 to V4.  
 Down: The frame will close in the order from V4 to V1.

## Chapter 4 Setting and operation (TMCR, TMCP)

### 1. Checking items before using the device

Before you use AFC at the first time after the installation, check the following settings "1-1." to "1-5."

#### 1-1. AFC setting

This setting makes AFC available for use.



This function requires inputting of a password. For details, refer to the user's manual of this machine.

[Procedure]



"main screen" → P7 → 77 Optional device (hardware) → 10 AFC

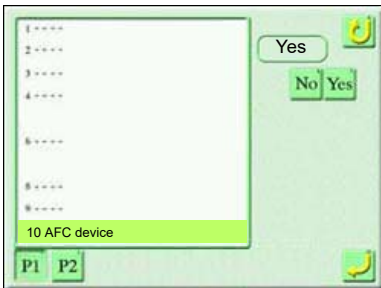

Setting range

Yes: AFC device is equipped.

No: AFC device is not equipped.

Example: Yes

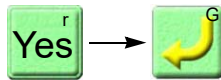

#### 1-2. Stop at Lower D.Point

The machine will stop with needle stuck in the fabric (stop at the lower dead point).



This function requires inputting of a password. For details, refer to the user's manual of this machine.

This function can minimize design displacement at frame travel in continuous design by using AFC frame.

[Procedure]



"main screen" → P7 → 76 Stop position → 1 Stop at Lower Dead Point

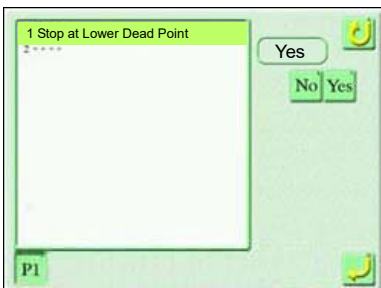

Setting range

Yes: Stop at Lower Dead Point is performed.

No: Stop at Lower Dead Point is not performed.

Example: Yes

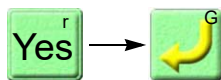

### 1-3. Return Frame at Lower D. Point

This is the setting to return the frame by manual offset even after frame travel during Stop at Lower Dead Point.



This function requires inputting of a password. For details, refer to the user's manual of this machine.

[Procedure]



"main screen" → P7 → 76 Stop position → 2 Return Frame at Lower dead point

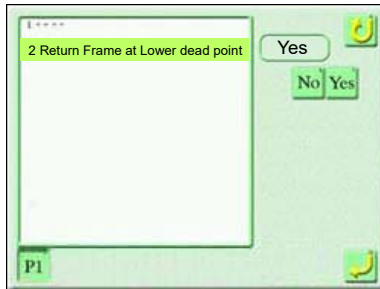

Setting range

Yes: The frame is returned by manual offset.

No : The frame is returned by manual offset. However, the amount of frame travel remains during stop at the lower dead point.

Example: Yes

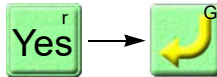

### 1-4. Air Pressure Sensor

This setting will stop the machine when air pressure of an air compressor decreases.



This function requires inputting of a password. For details, refer to the user's manual of this machine.

[Procedure]



"main screen" → P7 → 77 Optional device (hardware) → 8 Air pressure cofirmation switch

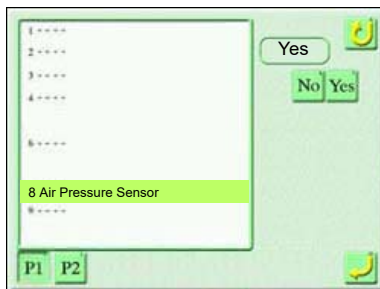

Setting range

Yes: air pressure is confirmed.

No: air pressure is not confirmed.

Press "Yes" to use this function if the optional item which needs air compressor is equipped.

Example: Yes

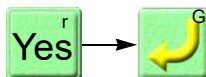

## 1-5. AFC automatic control

Select whether or not to automatically control the AFC device (open/close the AFC frame valve by automatic sequence and automatically start the machine) after the completion of embroidery.

[Procedure]



"main screen" → P5 → 47 AFC automatic control

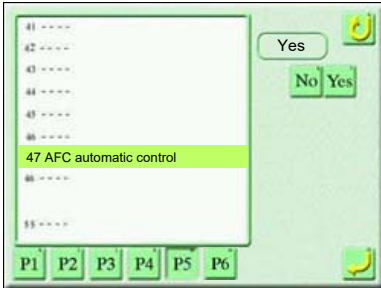

Setting range

Yes: Enable automatic control.

No: Do not enable automatic control.

If you select "No", the frame weight data for the AFC frame will be used to operate the frame similarly to a border frame.

Example: Yes

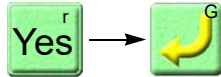

## 2. To open/close the frame manually

Turn ON/OFF the selected valve (V1 to V4) to open/close the frame.

**⚠ Caution**

⊘ When performing this working, do not put your hands under the needle or on the table. You could be injured by opening/closing frame.

[Procedure]

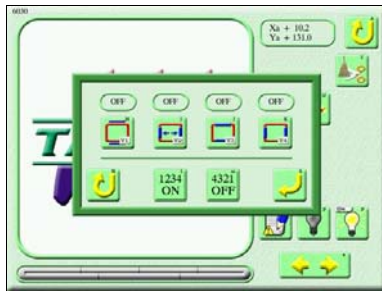
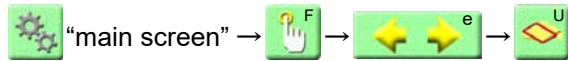

Setting range

- V1: table presser
    - ON: fixing fabric
    - OFF: releasing fabric
  - V2: fabric stretching
    - ON: releasing fabric
    - OFF: stretching fabric
  - V3: crosswise sash
    - ON: releasing fabric
    - OFF: fixing fabric
  - V4: Lengthwise sash
    - ON: releasing fabric
    - OFF: fixing fabric
- 1234 ON: the valve will open in the order from V1 to V4.  
4321 OFF: the valve will close in the order from V4 to V1.

Example: V2: fabric stretcher

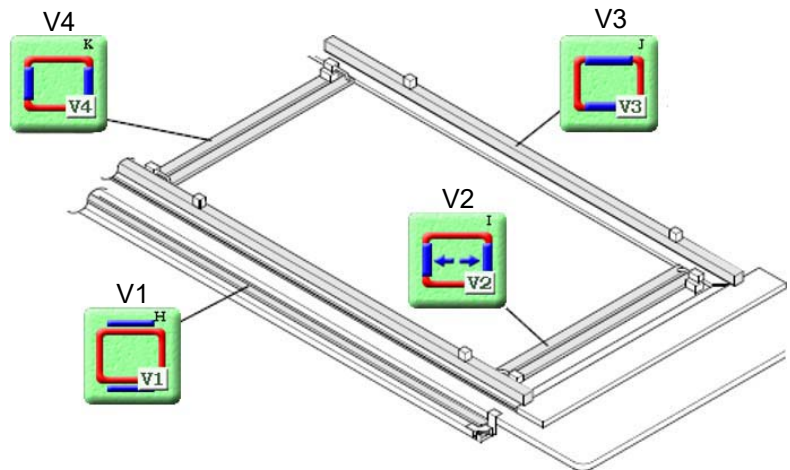
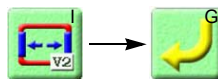

## Chapter 5 Adjustment of each part

### 1. Adjustment of fabric stretching amount

#### 1-1. Lengthwise (Y-axis) sash

Adjust stretching of the fabric.

(1) Loosen the screw (1 in the figure below).

(2) Make the adjuster 2 touch the plate 3, and tighten the screw 1.



Adjusting the fixing position of 2 change the fabric stretching amount 4.

In case of use of much elastic fabric or wide width fabric, increase fabric stretching amount.

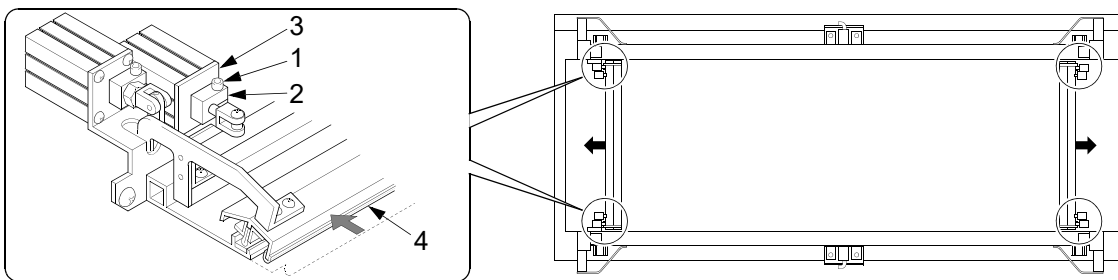

#### 1-2. Horizontal (X-axis) sash

Fine adjust the spot where the holding power of stretching fabric is weak partially.

(1) Loosen the screws (1 in the figure below) of the spot where the holding power of stretching fabric is weak by using the wrench 2.

(2) Turn the pipe 4 by hand to the position where the fabric presser 3 stops.

(3) Tighten the screw 1.

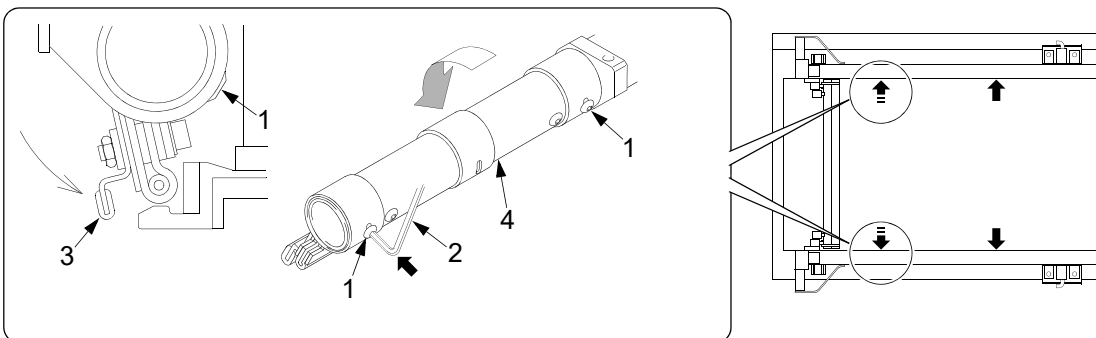

Tighten 1 pushing 3 by the tip of the finger as shown left.

### 1-3. Table presser

#### ■ Adjust to the thickness of the fabric

Adjust a gap (right figure A) between the pipe 1 and pipe 2 according to the thickness of the fabric.

<How to adjust>

Loosen the screw 3, and adjust a gap A.

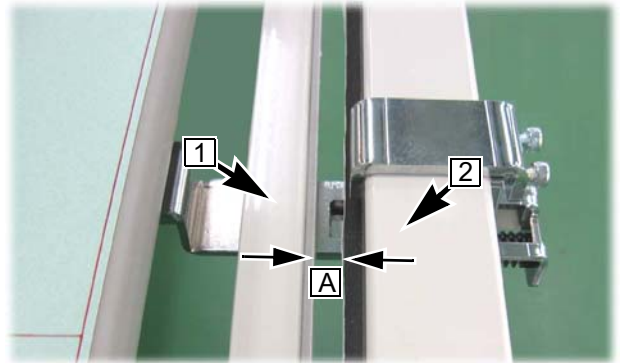
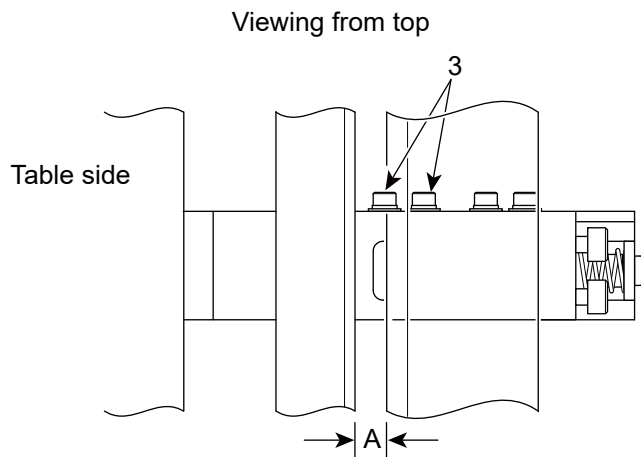

#### ■ Adjust stretching of the fabric

When the pipe 1 pushes to move the pipe 2, adjust the position (right figure B) where 2 stops.

<How to adjust>

Loosen the screw 4, and adjust the position B where 2 stops.



When you want to stretch the fabric strongly, fix 2 at the rightish position.

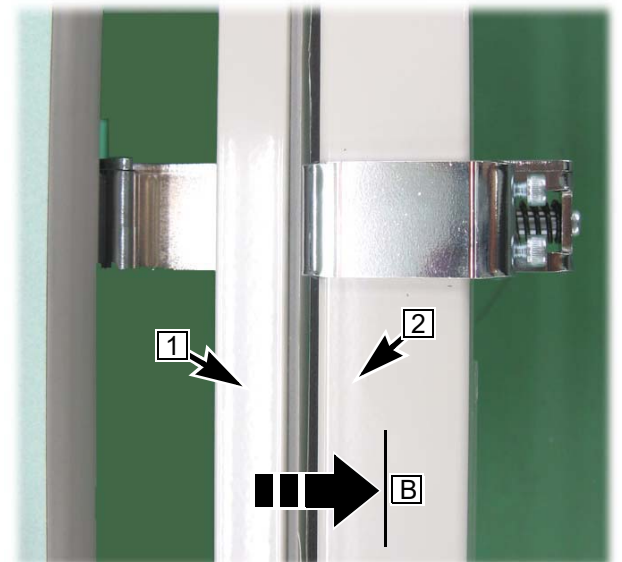
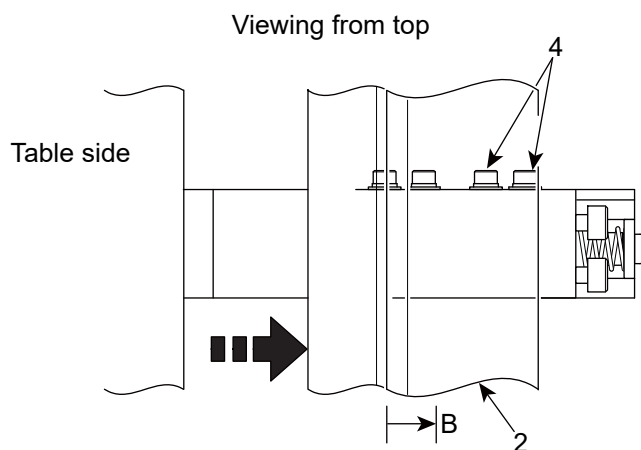

## 2. Adjustment of lengthwise (Y-axis) sash

### 2-1. Height of lengthwise (Y-axis) sash

Adjust the lengthwise (Y-axis) sashes so that the presser sashes do not touch heads when the lengthwise (Y-axis) sashes release the fabric.

- (1) Turn OFF the power of the machine (It is possible to move the frame by hand).
- (2) Detach the supplier air hose (It is possible to open/close the presser sash by hand).

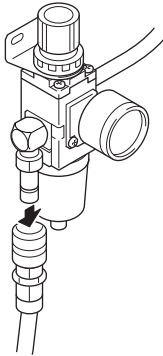

- (3) Loosen the screw 1.

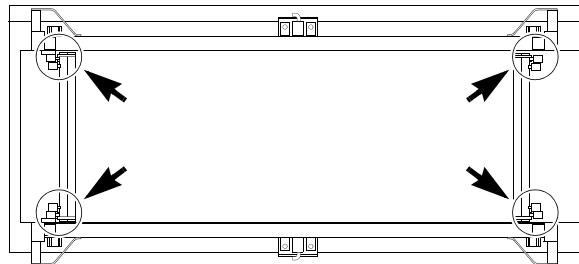
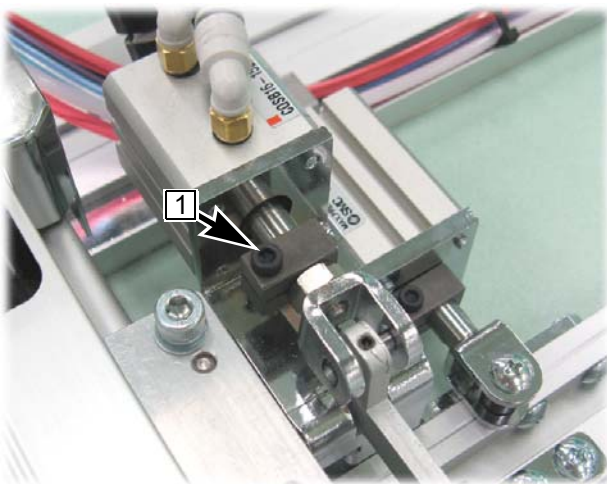

- (4) Move the frame by hand to move the presser sash 2 to under the head 3.
- (5) Lift the presser sash 2, make the adjuster 4 touch the plate 5 in the height so that 2 does not touch the head 3, and then tighten the screw 1.

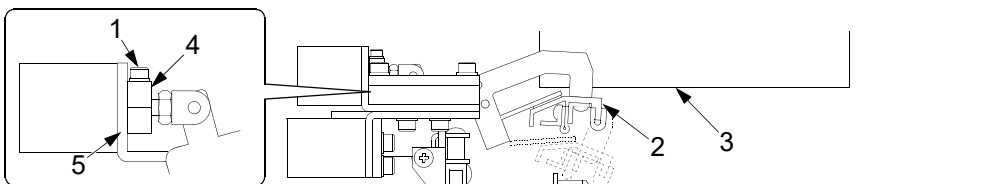

- (6) Turn ON the power of the machine afterward, and perform the following operations.

\* For details, refer to the user's manual of the machine.

- [a] TMCR, TMCP: absolute origin search
- [b] TLMX, TCMX: frame origin memory

## 2-2. Position adjustment of the vertical (Y-axis) sash according to fabric width

When the position of the lengthwise (Y-axis) sash is different from fabric width, change the position of the lengthwise (Y-axis) sash.

- (1) Decide a position of the fabric.
- (2) Slide the lengthwise (Y-axis) sashes by loosening the screws (1 in the figure below) to adjust the position so that the lengthwise sashes can press the end of the fabric.
- (3) Align the position of the lengthwise (Y-axis) sashes by using the graduation 3 of the traverse scale so that the lengthwise (Y-axis) sashes do not become aslant.
- (4) Tighten the screw 1.

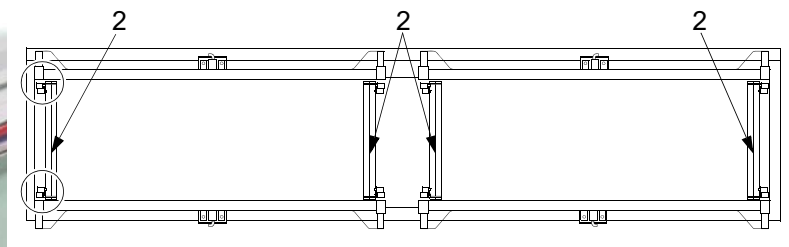
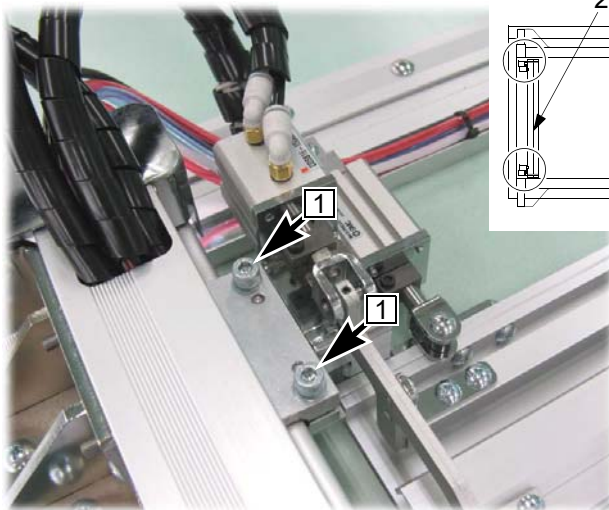
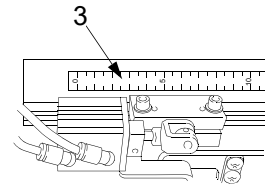

## 2-3. Extension of air pipe

When length of air tube comes short due to changing position (2-2. described above) of the lengthwise (Y-axis) sash, change the air tube.

- (1) Set air pressure of the regulator to 0 ( → p.3).
- (2) Disconnect the corresponding air tubes (1 in the figure below) from the air cylinder and the joint 2.



Connect/disconnect the air tube 1 and the joint 2 while pressing the release bushing 3.

- (3) Connect air tubes with necessary length to the joint 2 and air cylinder.

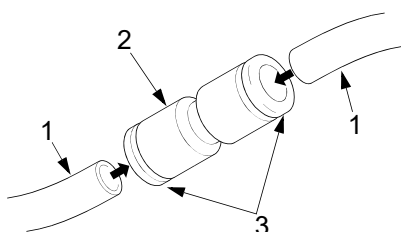

## Chapter 6 Attaching/detaching of needle bar case, dummy case

Regarding the head with which lower part of needle bar case interferes with the AFC frame, which disables embroidery, detach the needle bar case and attach the dummy case. When you detach the AFC frame, change the dummy case to the needle bar case.

### CAUTION

- ❗ When performing this working, turn OFF the power. You could be injured by unexpected movement of the machine.
- ❗ When performing this working, please consult the distributor. Attaching parts by mistake and/or improper adjustment will cause malfunctioning of the machine.

## 1. Detaching

### 1-1. Needle bar case

- (1) Turn OFF the power.
- (2) Detach the front cover (1 in the figure below).
- (3) Detach the tension base cover 2 to disconnect the harness 3 (The number of 3 differs depending on model and/or head).
- (4) Remove the screws 4 to detach the tension base 5.
- (5) Remove the screw 6 to detach the tension base bracket 7.
- (6) Remove the screws 7 to detach the take-up lever cover 8.
- (7) Remove the screws 9 to detach the bracket 10 (Existence/absence of 10 differs depending on model).
- (8) Remove the screws 11 to detach the needle bar case 12.

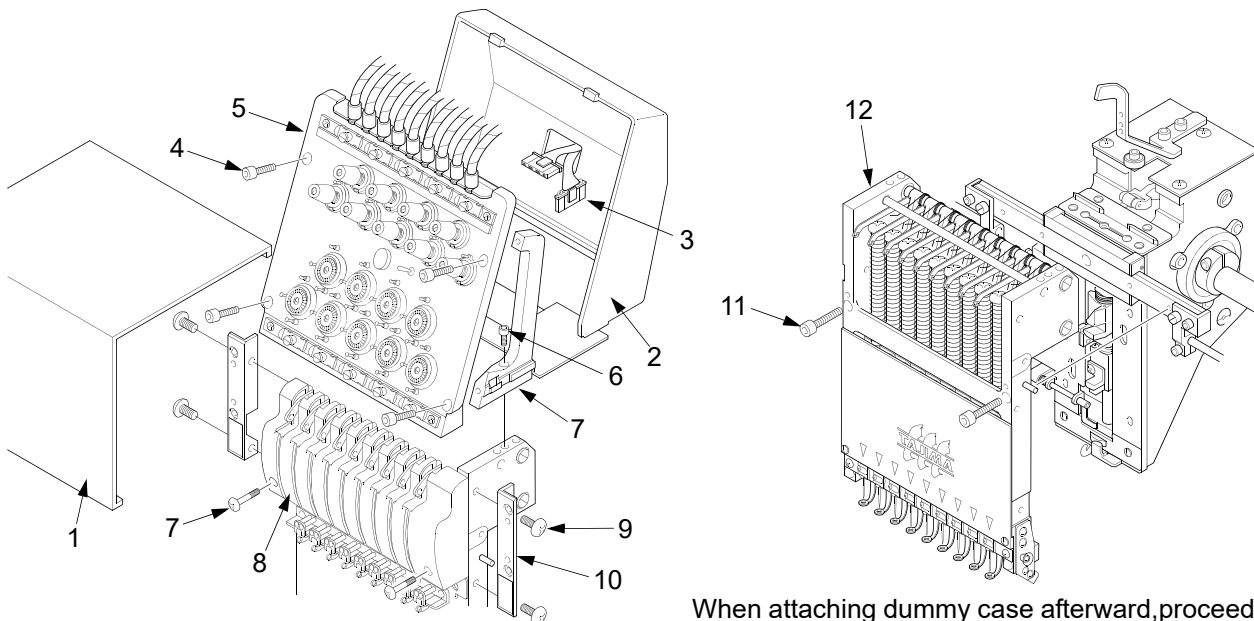

When attaching dummy case afterward, proceed to 2-2. of p.22.

## 1-2. Dummy case

- (1) Turn OFF the power.
- (2) Detach the front cover (1 in the figure below).
- (3) Detach the tension base cover 2 to disconnect the harness 3 (The number of 3 differs depending on model and/or head).
- (4) Remove the screws 4 to detach the tension base 5.
- (5) Remove the screw 6 to detach the tension base bracket 7.
- (6) Remove the screws 8 to detach the bracket 9 (Existence/absence of 9 differs depending on model).
- (7) Remove the screws 10 to detach the case cover 11.
- (8) Remove the screws 12 to detach the dummy case 13.

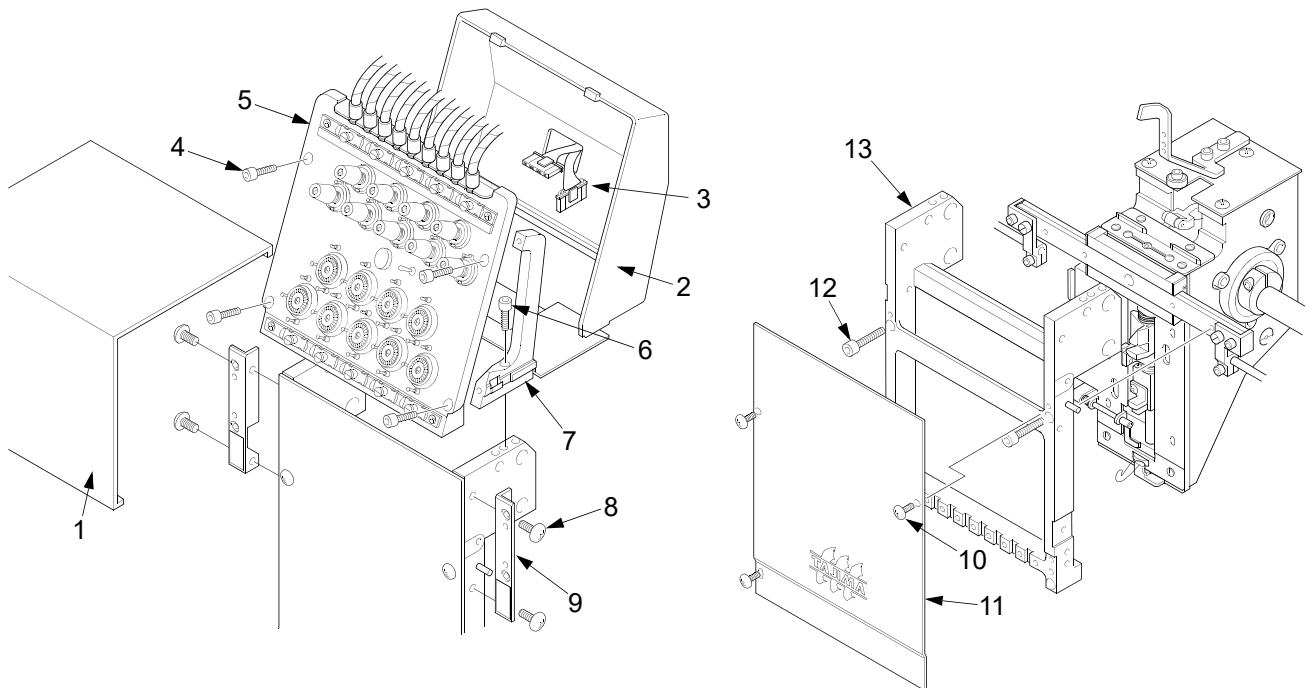

If attaching the needle bar case afterward, proceed to 2-1. of p.21.

## 2. Attaching

### 2-1. Needle bar case

- (1) Turn OFF the power.
- (2) Attach the needle bar case (1 in the figure below) to the case linear 2, and put the hook 4 in the upper thread holder base 5. Tighten the screw 3 in the state that 1 is pushed to the right.
- (3) Attach the tension base bracket 6 to 1, and tighten the screw 7.
- (4) Slide 1 to the last needle, and insert the sensor arm 9 into the card bracket 8 (Figure A). Attach the tension base 10 to 6, and tighten the screw 11.
- (5) Connect the harness 12 to 10 (The number of 12 differs depending on model and/or head). Attach the tension base cover 13 to 10.
- (6) Attach the take-up lever cover 14 and tighten the screws 15.
- (7) Attach the bracket 16 and tighten the screws 17 (Existence/absence of 16 differs depending on model).
- (8) Attach the front cover 18.

Fig. A

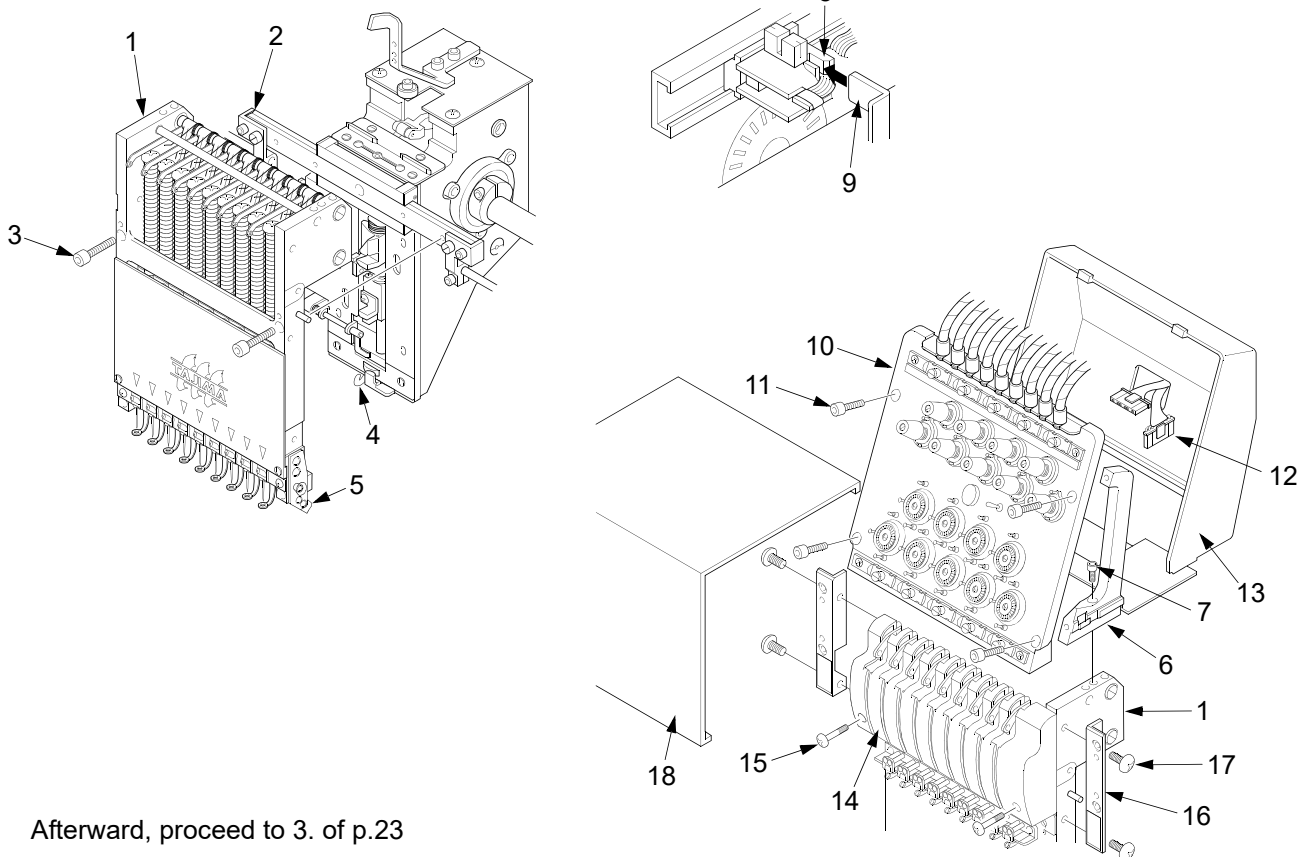

Afterward, proceed to 3. of p.23

## 2-2. Dummy case

- (1) Turn OFF the power.
- (2) Attach the dummy case (1 in the figure below) to the case linear 2, and tighten the screw 3.
- (3) Attach the case cover 4 to 1, and tighten the screw 5.
- (4) Slide 1 to the last needle, and insert the sensor arm 7 into the card bracket 6 (Figure A). Attach the tension base 8 to the bracket 9, and tighten the screw 10.
- (5) Connect the harness 11 to 8 (The number of 11 differs depending on model and/or head). Attach the tension base cover 12.
- (6) Attach the bracket 13 and tighten the screw 14 (Existence/absence of 13 differs depending on model).
- (7) Attach the front cover 15.

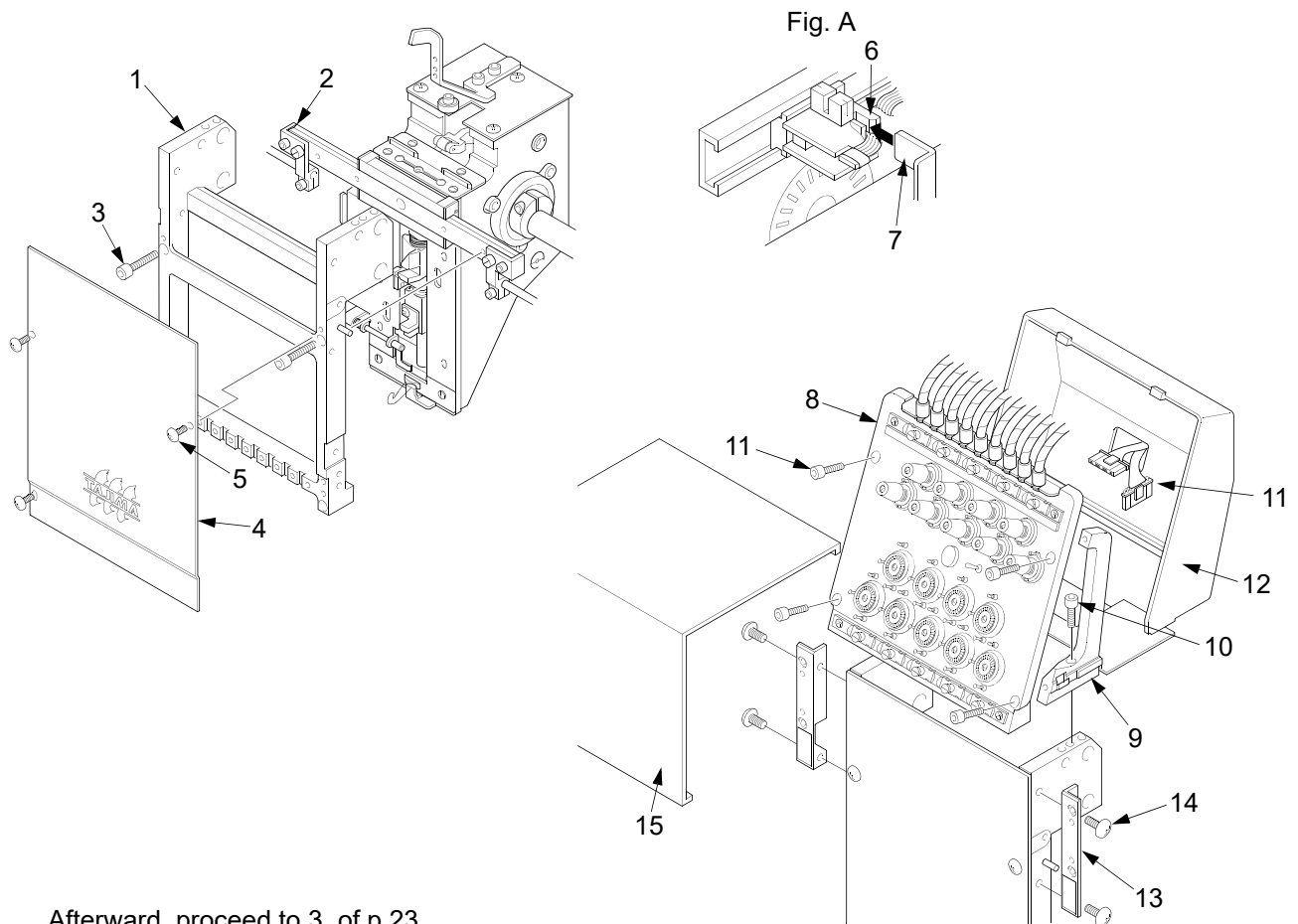

Afterward, proceed to 3. of p.23.

### 3. Replacement of needle plate

Change needle plate according to spec.

Normal needle plate

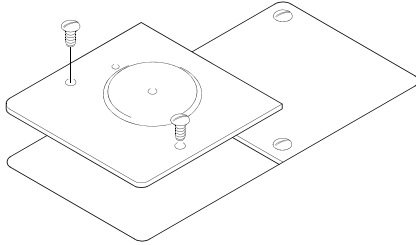

For dummy case

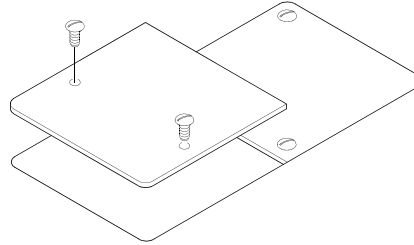

Check needle location at the first needle and the last needle. Loosen the screws 1 (right and left 2 spots) to adjust needle location.

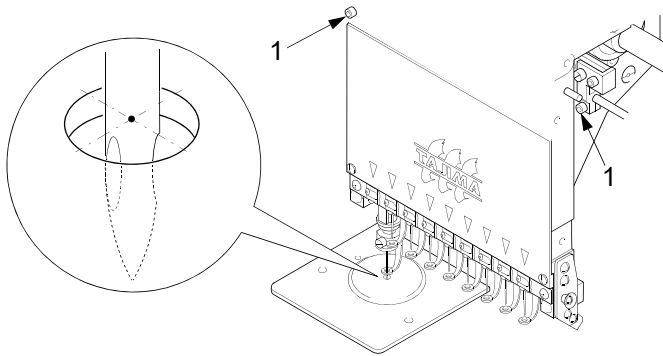

This completes the works.

1st Edition December, 2004

8th Edition September, 2019

■ **Manufactured by : TISM Co.,Ltd.**

Address : NO.1800, Ushiyama-cho, Kasugai, Aichi-pref., 486-0901, Japan

TEL : 81-568-33-1161 FAX : 81-568-33-1191

■ **Distributed by : Tajima Industries Ltd.**

Address : NO.1800, Ushiyama-cho, Kasugai, Aichi-pref., 486-0901, Japan

TEL : 81-568-37-1130 FAX : 81-568-37-1230

●**Copy, reprint, or reform of a part or whole of this manual without permission is prohibited.**